

# INTERPRETATION ACT, 1964



## ARRANGEMENT OF SECTIONS

<i>Section</i>	<i>Interpretation of enactments</i>	
<i>Preliminary</i>		
1. Application of this Act.	14. Gender and number.	
<i>Operation of enactments</i>		
2. Passing and commencement.	15. Time.	
3. Punctuation, headings and descriptive words.	16. Distance.	
4. Amended and substituted enactments.	17. Penalties.	
5. Construction of references to portions of enactments.	18. Interpretation of particular expressions, etc.	
6. Effect of repeals, expiration, etc.	19. Additional provisions as to interpretation of subsidiary instruments.	
7. Forfeiture.	<i>Miscellaneous</i>	
8. Civil remedy not excluded by other sanction.	20. Citation of Acts.	
9. Enactments binding the state.	21. Printing of enactments with textual amendments.	
<i>Construction of statutory powers and duties</i>		
10. Statutory powers and duties—general.	22. Deviations in forms.	
11. Appointments.	23. Execution of instruments made by the President.	
12. Additional provisions as to powers to make subsidiary instruments, etc.	24. Offences under more than one law.	
13. Payment to precede the performance of certain duties.	25. Service by post.	
	26. Special provisions as to certain statutory bodies.	
	<i>Supplementary</i>	
	27. Interpretation of this Act, etc.	
	28. Repeals and savings, etc.	
	29. Short title and extent.	
	SCHEDULE—Enactments repealed.	



## 1964, No. 1

AN ACT TO PROVIDE FOR THE CONSTRUCTION AND INTERPRETATION OF ACTS OF PARLIAMENT AND CERTAIN OTHER INSTRUMENTS ; AND FOR PURPOSES CONNECTED THEREWITH.

[20th January, 1964]

Commence-  
ment.

BE IT ENACTED by the Legislature of the Federation of Nigeria in this present Parliament assembled and by the authority of the same as follows :—

*Preliminary*

1. This Act shall apply to the provisions of any enactment except in so far as the contrary intention appears in this Act or the enactment in question.

Application  
of this Act.

*Operation of enactments*

2.—(1) An Act is passed when the President assents to the Bill for the Act, whether or not the Act then comes into force.

Passing and  
commence-  
ment.

(2) Where no other provision is made as to the time when a particular enactment is to come into force, it shall, subject to the following subsection, come into force—

(a) in the case of an enactment contained in an Act of Parliament, on the day when the Act is passed ;

(b) in any other case, on the day when the enactment is made.

(3) Where an enactment is expressed to come into force on a particular day, it shall be construed as coming into force immediately on the expiration of the previous day.

3.—(1) Punctuation forms part of an enactment, and regard shall be had to it accordingly in construing the enactment.

Punctuation,  
headings and  
descriptive  
words.

(2) A heading or marginal note to an enactment does not form part of the enactment and is intended for convenience of reference only.

(3) Words in an enactment descriptive of another enactment shall not be used as an aid to the construction of the other enactment and are intended for convenience of reference only.

4.—(1) A reference in an enactment to another enactment shall, if the other enactment has been amended, be construed as a reference to the other enactment as amended.

Amended  
and substi-  
tuted  
enactment

(2) Where an enactment is repealed and another enactment is substituted for it, then—

(a) the repealed enactment shall remain in force until the substituted enactment comes into force ;

(b) any reference to the repealed enactment shall, after the substituted enactment comes into force, be construed as a reference to the substituted enactment ;

(c) any subsidiary instrument in force by virtue of the repealed enactment shall, so far as the instrument is not inconsistent with the substituted enactment, continue in force as if made in pursuance of the substituted enactment.

Construction of references to portions of enactments.

5.—(1) Where an enactment describes a portion of another enactment in terms of a word occurring in the other enactment, that word is included in the portion described.

(2) Where an enactment describes a consecutive series of provisions of another enactment by reference to the first or last provision of the series, that provision is included in the series described.

Effect of repeals, expiration, etc.

6.—(1) The repeal of an enactment shall not—

(a) revive anything not in force or existing at the time when the repeal takes effect ;

(b) affect the previous operation of the enactment or anything duly done or suffered under the enactment ;

(c) affect any right, privilege, obligation or liability accrued or incurred under the enactment ;

(d) affect any penalty, forfeiture or punishment incurred in respect of any offence committed under the enactment ;

(e) affect any investigation, legal proceeding or remedy in respect of any such right, privilege, obligation, liability, penalty, forfeiture or punishment ;

and any such investigation, legal proceeding or remedy may be instituted, continued or enforced, and any such penalty, forfeiture or punishment may be imposed, as if the enactment had not been repealed.

(2) When an enactment expires, lapses or otherwise ceases to have effect, the foregoing subsection shall apply as if the enactment had then been repealed.

Forfeiture.

7. Where an enactment provides that any property shall be forfeited, the enactment shall be construed as providing that the property, or where the property is duly sold the proceeds of sale, shall vest in the Minister of the government of the Federation responsible for finance and be held by him for the purposes of the government of the Federation.

Civil remedy not excluded by other sanction.

8. An enactment shall not be construed as preventing the recovery of damages in respect of injury attributable to any act by reason only of the fact that the enactment provides for a penalty, forfeiture or punishment in respect of the act.

- 9.—(1) An enactment shall not prejudicially affect—
- (a) the executive authority of the Federation ; or
  - (b) any property in so far as it is held for the purposes of the government of the Federation.
- (2) The foregoing subsection shall not apply to an enactment—
- (a) if the enactment is expressed to bind the state ; or
  - (b) in so far as an enactment so provides by other express words or by necessary implication ;
- and the provisions of this section shall have effect notwithstanding anything in section one of this Act.

Enactments  
binding the  
state.

*Construction of statutory powers and duties*

- 10.—(1) Where an enactment confers a power or imposes a duty, the power may be exercised and the duty shall be performed from time to time as occasion requires.
- (2) An enactment which confers power to do any act shall be construed as also conferring all such other powers as are reasonably necessary to enable that act to be done or are incidental to the doing of it.
- (3) Where an Act is not to come into force immediately on the passing of the Act and confers power to make a subsidiary instrument, to give notices, to prescribe forms, to make an appointment or to do any other thing for the purposes of the Act, the power may be exercised at any time after the Act is passed so far as may be necessary or expedient for the purpose of bringing the Act into operation at the date of its commencement, so however that no subsidiary instrument made by virtue of this subsection shall come into force before the commencement of the Act conferring power to make the instrument except in so far as may be necessary for bringing that Act into force.

Statutory  
powers and  
duties—  
general.

- 11.—(1) Where an enactment confers a power to appoint a person either to an office or to exercise any functions, whether for a specified period or not, the power includes—
- (a) power to appoint a person by name or to appoint the holder from time to time of a particular office ;
  - (b) power to remove or suspend him ;
  - (c) power, exercisable in the manner and subject to the limitations and conditions (if any) applicable to the power to appoint,—
    - (i) to reappoint or reinstate him ;
    - (ii) to appoint a person to act in his place, either generally or in regard to specified functions, during such time as is considered expedient by the authority in whom the power of appointment in question is vested.
- (2) A reference in an enactment to the holder of an office shall be construed as including a reference to a person for the time being appointed to act in his place, either as respects the functions of the office generally or the functions in regard to which he is appointed, as the case may be.

Appoint-  
ments.

Additional provisions as to powers to make subsidiary instruments, etc.

12.—(1) Where an Act confers a power to make a subsidiary instrument, proclamation or notification, the power shall include—

- (a) power to make different provision for different circumstances ;
- (b) power, exercisable in the like manner and subject to the like consent and conditions (if any), to vary and revoke the instrument, proclamation or notification ;

(c) in the case of a subsidiary instrument, power to prescribe punishments for contraventions of provisions of the instrument, not exceeding as respects a particular contravention—

(i) in the case of rules of court, imprisonment for a term of three months or a fine of twenty-five pounds or both ;

(ii) in any other case, imprisonment for a term of six months or a fine of fifty pounds or both.

(2) A contravention of a provision of a subsidiary instrument may be prosecuted in a summary manner.

Payment to precede the performance of certain duties.

13. Where a sum of money is payable in respect of the performance of a duty imposed by an enactment on any person, that person may abstain from performing the duty until the sum is paid or, where the sum cannot be finally ascertained before the performance of the duty, until such an amount is paid as that person may reasonably estimate (without prejudice to its subsequent adjustment) to be the relevant sum.

#### *Interpretation of enactments*

Gender and number.

14. In an enactment—

- (a) words importing the masculine gender include females ;
- (b) words in the singular include the plural and words in the plural include the singular.

Time.

15.—(1) A reference in an enactment to the time of day is a reference to the time which is one hour in advance of Greenwich mean time.

(2) A reference in an enactment to a period of days shall be construed—

(a) where the period is reckoned from a particular event, as excluding the day on which the event occurs ;

(b) where apart from this paragraph the last day of the period is a holiday, as continuing until the end of the next following day which is not a holiday.

(3) Where by an enactment any act is authorised or required to be done on a particular day and that day is a holiday, it shall be deemed to be duly done if it is done on the next following day which is not a holiday.

(4) Where by an enactment any act is authorised or required to be done within a particular period which does not exceed six days, holidays shall be left out of account in computing the period.

(5) In this section “holiday” means a day which is a Sunday or a public holiday.

Distance.

16. In determining a distance for the purposes of an enactment, the distance shall be measured in a straight line on a horizontal plane.

17.—(1) Where a punishment in respect of an offence is provided by an enactment, the enactment shall be construed as providing that an offender shall be liable in pursuance of the enactment to a punishment not exceeding the punishment so provided. Penalties.

(2) Where imprisonment in respect of an offence is provided by an enactment, the enactment shall be construed as providing that any imprisonment imposed in pursuance of the enactment in respect of the offence shall be—

(a) with or without hard labour as the court imposing the imprisonment may in its discretion direct ;

(b) with hard labour if no such direction is given.

(3) Where a punishment is set out at the foot of an enactment, the enactment shall be construed as providing that a contravention of the enactment shall be an offence for which an offender shall be liable, subject to subsection (1) of this section, to the punishment so set out.

18.—(1) In an enactment the following expressions have the meanings hereby assigned to them respectively, that is to say—

“act” includes an omission, and references to the doing of an act shall be construed accordingly ;

“chief” means a person who, in accordance with the law in force in any part of Nigeria, is accorded the dignity of a chief by reference to that part or to a community established in that part ;

“commencement”, in relation to an enactment, means the time at which the enactment comes into force ;

“consular officer” includes consul-general, consul, vice-consul, consular agent and any person for the time being authorised to discharge the duties of a consul-general, consul or vice-consul ;

“contravention”, in relation to an enactment, includes a failure to comply with the enactment ;

“crew”, in relation to a ship or other vessel, includes masters, mates, pilots, engineers, stokers, deck-hands and all persons engaged in the navigation of the ship or other vessel ;

“Crown Agents” means the body established in the United Kingdom and commonly known as the Crown Agents for Oversea Governments and Administrations ;

“daily penalty”, “weekly penalty” and “monthly penalty”, in relation to an offence, means a penalty for each day, week or month, as the case may be, during which the offence is continued after conviction for the offence ;

“financial year” means the period of twelve months ending with the thirty-first day of March in any year ;

“immovable property” means land ;

“inland waters” includes all rivers, creeks and lagoons inside the river bars of Nigeria ;

“Lagos” means the Federal territory within the meaning of the Constitution of the Federation ;

“land” includes any building and any other thing attached to the earth or permanently fastened to any thing so attached, but does not include minerals ;

Interpretation of particular expressions, etc.

“Law” means any law enacted or having effect as if enacted by the legislature of a Region and includes any instrument having the force of law which is made under a Law ;

1962.  
No. 33.

“legal practitioner” has the meaning assigned to it by the Legal Practitioners Act, 1962 ;

“local authority” means the local authority of a township ;

“master”, in relation to a ship, means any person other than a pilot or harbour master having for the time being control or charge of the ship ;

“military forces” means the armed forces of the Federation and includes any person who is not a member of the last-mentioned forces but who accompanies, or is employed in the service of, a body of those forces ;

“Minister”, where no particular Minister is specified in the context, means the Minister of the government of the Federation charged in pursuance of the Constitution of the Federation with responsibility for the matter to which the context relates ;

“monogamous marriage” means a marriage which is recognised by the law of the place where it is contracted as a voluntary union of one man and one woman to the exclusion of all others during the continuance of the marriage ;

“month” means a calendar month reckoned according to the Gregorian calendar ;

“oath” and “affidavit”, in relation to a person authorised by law to make an affirmation or declaration instead of an oath, includes an affirmation or declaration made in accordance with the relevant law, and “swear” shall be construed accordingly ;

“person” includes any body of persons corporate or unincorporate ;

“police officer” means any member of a police force and “superior police officer” means a police officer of or above the rank of assistant superintendent ;

“prescribed” means prescribed by or under the enactment in which the expression occurs ;

“public holiday” means a day which is a public holiday—

(a) as respects Lagos, by virtue of the Public Holidays Act ;

(b) as respects any other part of Nigeria, by virtue of any corresponding enactment in force in that part ;

“public officer” means a member of the public service of the Federation within the meaning of the Constitution of the Federation or of the public service of a Region within the meaning of the constitution of the Region ;

Cap. 166.

“qualified medical practitioner” means a person who is a fully registered medical practitioner within the meaning of the Medical and Dental Practitioners Act, 1963 ;

1963, No. 9

“regulations”, in an enactment passed or made before the passing of this Act, includes rules and byelaws ;

“to sell” includes to exchange and to barter and to offer or expose for sale ;

“seaman” includes every person (other than a master, pilot or indentured apprentice) who is employed or engaged in any capacity on board a ship ;

“ship” includes every description of vessel used in navigation and not exclusively propelled by oars or paddles ;

“to sign”, in relation to a person who is unable to write his name, means to make his mark ;

“territorial waters” means any part of the open sea within three nautical miles of the coast of Nigeria (measured from low water mark) or of the seaward limits of inland waters ;

“township” means a township established under the Townships Act ;

“urban district” means an urban district established under the Townships Act ;

“vessel” includes floating craft of every description ;

“will” includes a codicil ;

“writing” and expressions referring to writing include printing, lithography, photography, typewriting and other modes of representing or reproducing words or figures in a visible form ; and

“year” means a period of twelve months.

(2) Where by the foregoing subsection or any other enactment a meaning is assigned to a word, parts of speech related to the word have corresponding meanings.

(3) The word “or” and the word “other” shall, in any enactment, be construed disjunctively and not as implying similarity.

(4) A reference in an enactment, in relation to any functions, to an official described by a designation which under the system of government in force in a particular part of Nigeria is no longer appropriate in relation to those functions shall be construed, in relation to those functions and that part, as a reference to the person on whom the functions have devolved under the system of government for the time being in force in that part.

19.—(1) An expression used in a subsidiary instrument has the same meaning as in the Act conferring power to make the instrument.

(2) In a subsidiary instrument, the expression “the Act” means the Act conferring power to make the instrument.

Additional provisions as to interpretation of subsidiary instruments.

### Miscellaneous

#### 20. An Act may be cited—

(a) in the case of an Act included in a revised edition of Acts of Parliament which is in force by virtue of an enactment, by its chapter number in that edition ;

(b) in the case of any other Act, by the number of the year in which it was passed and its number among the Acts passed in that year ; and the mode of citation authorised by this section shall be in addition to any other mode of citation authorised by any other enactment.

Citation of Acts.

Printing of enactments with textual amendments.

21.—(1) Where an enactment is amended by the insertion or omission of words or by the substitution of words for other words, then on printing the enactment at any time after the amendment takes effect the person authorised to print the enactment shall, if so directed by the Attorney-General of the Federation, print the enactment as so amended.

(2) A direction under the foregoing subsection in respect of any amendment shall include provision requiring the printer to indicate, in such a manner as may be specified by the direction, the extent of the amendment and the enactment by which it was made.

Deviations in forms.

22. Where a form is prescribed by an enactment, a form which differs from the prescribed form shall not be invalid for the purposes of the enactment by reason only of the difference if the difference is not in a material particular and is not calculated to mislead.

Execution of instruments made by the President.

23. Where a power to make an instrument which is conferred on the President by an enactment is exercisable in accordance with the advice of the Council of Ministers or a Minister of the government of the Federation, then, without prejudice to the exercise of the power by the President in person, any instrument made in exercise of that power may be executed under the hand of the Secretary to the Prime Minister or the Deputy Secretary to the Council of Ministers.

Offences under more than one law.

24. Where an act constitutes an offence under two or more enactments or under an enactment and at common law, the alleged offender shall be liable to be prosecuted and on conviction punished under any one of the enactments or, as the case may be, either under the enactment or at common law, but shall not be liable to be punished twice for the same offence.

Service by post.

25. Where an enactment authorises or requires a document to be served by post, whether the word "serve" or some other word is used, then—

(a) the document may be served by posting an envelope—

(i) which contains the document ; and

(ii) on which the postage (where any is payable) has been prepaid ; and

(iii) which is addressed to the person on whom it is to be served at his last known address ; and

(b) where the provisions of paragraph (a) of this section have been satisfied as respects the document, it shall be deemed to have been served at the time at which the envelope would have been delivered in the ordinary course of post unless it is proved that the envelope was not delivered at that time.

Special provisions as to certain statutory bodies.

26. Where a body established by an enactment comprises three or more persons, then—

(a) any act which the body is authorised or required to do may be done in the name of the body by a majority of those persons or of a quorum of them ; and

(b) in any vote taken at a meeting of the body the person presiding when the vote is ordered shall have a casting vote, whether or not he also has a deliberative vote.

*Supplementary*

27.—(1) Without prejudice to the provisions of section eighteen of this Act, in this Act the following expressions have the meanings hereby assigned to them respectively, that is to say—

Interpretation of this Act, etc.

“Act” means an Act of Parliament, whether passed before or after the commencement of this Act, and includes this Act and an instrument made before the first day of October, 1960, in so far as the instrument has effect as an Act ;

“enactment” means any provision of an Act or subsidiary instrument ;

“subsidiary instrument” means any order, rules, regulations, rules of court or byelaws made either before or after the commencement of this Act in exercise of powers conferred by an Act.

(2) Nothing in this Act shall be construed as purporting to prejudice the provisions of the Constitution of the Federation.

1963, No. 20.

(3) This Act binds the state.

28.—(1) Subject to subsections (3) and (4) of this section, the enactments specified in the first and second columns of the Schedule to this Act are hereby repealed to the extent shown in the third column of that Schedule.

Repeals and savings, etc.

(2) Subject to subsection (3) of this section, so much of the Interpretation Act as is not repealed by this section may be cited as the Law (Miscellaneous Provisions) Act, and accordingly for section one of that Act there shall be substituted the following section :—

Cap. 89.

“1. This Act may be cited as the Law (Miscellaneous Provisions) Act”.

(3) Nothing in the foregoing provisions of this section shall be construed as affecting the operation of the Interpretation Act to the extent (if any) to which that Act has effect as part of, or in relation to, the law of a Region within the meaning of section one hundred and fifty-four of the Constitution of the Federation.

(4) Nothing in subsection (1) of this section shall be construed as affecting the provisions of the Interpretation (Amendment) Act, 1958.

No. 42 of 1958.

29. This Act may be cited as the Interpretation Act, 1964, and shall apply throughout the Federation.

Short title and extent.

## Section 28

## SCHEDULE

## Enactments repealed

<i>Chapter or number</i>	<i>Short title</i>	<i>Extent of repeal</i>
Cap. 89.	The Interpretation Act.	Sections two to four, sections six to fourteen, sections seventeen to twenty-eight, sections thirty to forty-three, sections forty-six to fifty-seven, section fifty-nine, section sixty, sections sixty-two to sixty-six, subsection (2) of section sixty-eight, section sixty-nine, section seventy, in section seventy-two the words "and the Southern Cameroons", and in section seventy-three the words "Northern or Southern" in both places where they occur.
L.N. 258 of 1959.	The Transfer of Functions (Federation) Order, 1959.	So much of the Second Schedule as relates to the Interpretation Act.
No. 55 of 1960.	The Interpretation (Amendment) Act, 1960.	The whole Act.
L.N. 22 of 1960.	The Adaptation of Laws (Miscellaneous Provisions) Order, 1960.	So much of the Schedule as relates to the Interpretation Act.
L.N. 155 of 1960.	The Adaptation of Laws (Federal Provisions) Order, 1960.	So much of the Schedule as relates to the Interpretation Act.
L.N. 156 of 1960.	The Adaptation of Laws (Cameroons Provisions) Order, 1960.	So much of the Schedule as relates to section three of the Interpretation Act.
1961, No. 50.	The Acts Authentication Act, 1961.	In section three, in subsection (1), the words from "and unless" onwards.
1962, No. 33.	The Legal Practitioners Act, 1962.	In section twenty, in subsection (3), the words from "and the enactment" onwards. In the Third Schedule, Part II.
1963, No. 9.	The Medical and Dental Practitioners Act, 1963.	Subsection (7) of section seven-teen.

# CONSTITUTION (INTERPRETATION) ACT, 1964



## 1964, No. 2

AN ACT TO PROVIDE FOR THE APPLICATION OF THE INTERPRETATION ACT, 1964, TO THE CONSTITUTION OF THE FEDERATION ; AND FOR PURPOSES CONNECTED THEREWITH.

[See section 2 (2)]

Commence-  
ment.

BE IT ENACTED by the Legislature of the Federation of Nigeria in this present Parliament assembled and by the authority of the same as follows :—

1.—(1) The Interpretation Act, 1964, shall—

(a) apply and be deemed always to have applied to the Constitution as it applies to other Acts of Parliament ; and

(b) be deemed in its application to the Constitution to have come into force on the thirtieth day of September, 1963.

(2) The provisions mentioned in subsection (1) of section one hundred and fifty-four of the Constitution (which repeals superseded constitutional provisions) shall be deemed for the purposes of the Interpretation Act, 1964, in its application to the Constitution to be enactments within the meaning of that Act.

(3) Accordingly the references to the Interpretation Act in subsection (3) of section one hundred and fifty-five and subsection (4) of section one hundred and sixty-five of the Constitution shall be deemed always to have been references to the Interpretation Act, 1964.

(4) In this section “the Constitution” means the Constitution of the Federation.

2.—(1) This Act may be cited as the Constitution (Interpretation) Act, 1964, and shall apply throughout the Federation.

(2) This Act shall come into force on such date as the President may by order appoint.

Application  
to Constitu-  
tion of 1964,  
No. 1.

Short title,  
extent and  
Commence-  
ment.



THE UNIVERSITY OF CHICAGO  
LIBRARY

# CONSTITUTION OF MID-WESTERN NIGERIA ACT, 1964



## ARRANGEMENT OF SECTIONS

### Section

- |   |   |
|---|---|
| <ol style="list-style-type: none"> <li>1. Constitution for Mid-Western Region.</li> <li>2. Transitional operation of 1963, No. 19.</li> </ol> | <ol style="list-style-type: none"> <li>3. Commencement of this Act</li> <li>4. Short title and extent.</li> </ol> |
|---|---|

## SCHEDULE

### CHAPTER I

#### THE GOVERNOR

1. Establishment and tenure of office of Governor.
2. Oaths to be taken by Governor.
3. Discharge of Governor's functions during vacancy, etc.

### CHAPTER II

#### THE LEGISLATURE

##### *Part I.—Composition of Legislature*

4. Establishment of Legislature.
5. Composition of House of Chiefs.
6. Composition of House of Assembly.
7. Qualifications for membership of House of Assembly.
8. Disqualifications for membership of House of Assembly, etc.
9. President of House of Chiefs.
10. Speaker of House of Assembly.
11. Right of attendance of Ministers.
12. Tenure of seats of members of House of Assembly.
13. Establishment of Electoral Commission.
14. Constituencies.
15. Elections.

16. Determination of questions of membership of Legislative Houses.

17. Clerks to Legislative Houses and their staffs.

##### *Part II.—Procedure in Legislative Houses*

18. Oaths to be taken by members of Legislative Houses.
19. Presiding in House of Chiefs.
20. Presiding in House of Assembly.
21. Quorum in Legislative Houses.
22. Use of English in Legislative Houses.
23. Voting in Legislative Houses.
24. Unqualified persons sitting or voting.
25. Mode of exercising legislative power.
26. Restrictions with regard to certain financial measures.
27. Limitation of powers of House of Chiefs.
28. Regulation of procedure in Legislative Houses.
29. Interpretation of Part II.

##### *Part III.—Summoning, prorogation and dissolution*

30. Sessions of Legislative Houses.
31. Prorogation and dissolution of Legislative Houses.

## CHAPTER III

## EXECUTIVE POWERS

32. Exercise of executive authority of Region.
33. Ministers of Government of Region.
34. Establishment of Executive Council.
35. Collective responsibility.
36. Allocation of portfolios to Ministers.
37. Performance of functions of Premier during absence, etc.
38. Exercise of Governor's powers.
39. Governor to be informed concerning matters of government.
40. Parliamentary Secretaries.
41. Oaths to be taken by Ministers, etc.
42. Permanent secretaries.
43. Constitution of offices for Region, etc.
44. Prerogative of mercy.
45. Establishment of Advisory Council on Prerogative of Mercy.
46. Functions of Advisory Council.
47. Public prosecutions.

## CHAPTER IV

## COURTS

48. Establishment of High Court.
49. Appointment of judges of High Court.
50. Tenure of offices of judges of High Court.
51. Appeals to High Court from subordinate courts.
52. Power to establish Regional Court of Appeal.
53. Oaths to be taken by judges.

## CHAPTER V

## FINANCE

54. Establishment of Consolidated Revenue Fund.
55. Authorization of expenditure from Consolidated Revenue Fund.

56. Authorization of expenditure in advance of appropriation.
57. Contingencies Fund.
58. Remuneration of Governor and certain other officers.
59. Audit of public accounts.
60. Public debt.

## CHAPTER VI

## THE PUBLIC SERVICE OF THE REGION

61. Establishment of Public Service Commission.
62. Appointment etc. of officers in public service.
63. Appointment etc. of Deputy Governor.
64. Appointment etc. of Agent-General in United Kingdom.
65. Appointment etc. of permanent secretaries.
66. Qualifications of Director of Public Prosecutions.
67. Appointment and tenure of office of Director of Audit.
68. Powers relating to Clerks of Legislative Houses.
69. Powers of Commissions in relation to grant of pensions, etc.

## CHAPTER VII

## MISCELLANEOUS

70. Appointment of justices of the peace.
71. Powers and procedure of Commissions.
72. Establishment of provincial administrations.
73. Resignations.
74. Re-appointments, etc.
75. Interpretation, etc.—general.
76. Transitional provisions.

## SCHEDULES:

First Schedule—Special areas, etc.

Second Schedule—Transitional provisions.

## 1964, No. 3

AN ACT TO MAKE PROVISION FOR THE CONSTITUTION OF MID-WESTERN NIGERIA ;  
AND FOR PURPOSES CONNECTED THEREWITH.

[See section 3]

Commence-  
ment.

BE IT ENACTED by the Legislature of the Federation of Nigeria in this present Parliament assembled and by the authority of the same as follows :—

1. Subject to the provisions of the Constitution of the Federation, the constitution set out in the Schedule to this Act shall be the constitution of Mid-Western Nigeria.

Constitution  
for Mid-  
Western  
Region.

2. The Mid-Western Region (Transitional Provisions) Act, 1963, shall have effect as if the reference in paragraph (a) of subsection (1) of section one of that Act to the time there mentioned were a reference to the day appointed in pursuance of subsection (3) of section three of this Act ; and that Act is hereby repealed on that day.

Transitional  
operation of  
1963, No. 19.

3.—(1) This Act shall be deemed to have come into force on the first day of November, 1963, in so far as it makes provision (either in connection with constituencies, elections, qualifications, determination of questions, the operation of laws or otherwise howsoever) relating to members of the House of Assembly of the Region ; so however that, without prejudice to the operation of any law in force in the Region at any time before the passing of this Act, it shall, in so far as it modifies any law with respect to offences or punishment, come into force for the purposes of this subsection on the date on which it is passed.

Commence-  
ment of this  
Act.

(2) Section two of this Act shall come into force on the date on which this Act is passed.

(3) Subject to the foregoing provisions of this section, this Act shall come into force on such day as the Prime Minister may by order appoint.

4. This Act may be cited as the Constitution of Mid-Western Nigeria Act, 1964, and shall apply throughout the Federation.

Short title  
and extent.

## SCHEDULE

## Section 1

## THE CONSTITUTION OF MID-WESTERN NIGERIA

## CHAPTER I

## THE GOVERNOR

1.—(1) There shall be a Governor of the Region who shall, subject to the provisions of this section, be appointed by the President, acting in accordance with the advice of the Premier, and shall, subject as aforesaid, hold office for a term of five years.

Establish-  
ment and  
tenure of  
office of  
Governor.

(2) The office of Governor shall become vacant—  
 (a) on the expiration of his term of office ;  
 (b) if he dies ;  
 (c) if he resigns ; or  
 (d) if he is removed from office by the President, acting in accordance with the advice of the Premier.

(3) The Premier shall consult the Prime Minister of the Federation before tendering any advice to the President for the purposes of this section.

Oaths to be taken by Governor.

2. A person appointed to the office of Governor shall, before entering upon the duties of that office, take and subscribe, before the Chief Justice of the Region, the oath of allegiance and such oath for the due execution of the office as may be prescribed by the Legislature of the Region.

Discharge of Governor's functions during vacancy, etc.

3. Whenever the office of Governor is vacant or the holder of the office is absent from Nigeria or is in the opinion of the Premier for any reason unable to perform the functions conferred upon him by this Constitution, those functions shall be performed by such person as the President, acting in accordance with the advice of the Premier, may appoint or, if there is no person in the Region so appointed and able to perform those functions, by the President of the House of Chiefs :

Provided that nothing in this section shall preclude the Governor from performing any of those functions at any time when he is absent from Nigeria.

## CHAPTER II

### THE LEGISLATURE

#### *Part I.—Composition of Legislature*

Establishment of Legislature.

4. There shall be a Legislature for the Region, which shall consist of the Governor, a House of Chiefs and a House of Assembly and which shall have power to make laws for the peace, order and good government of the Region.

Composition of House of Chiefs.

5.—(1) Without prejudice to the provisions of section 9 of this Constitution, the House of Chiefs shall consist of—

(a) the Oba of Benin, the Olu of Warri and the persons for the time being holding such other chieftaincies as may be prescribed by the Governor, who shall be *ex-officio* members of the House ;

(b) fifty-one Chiefs having such qualifications and selected in such manner as may be prescribed by the Legislature of the Region ;

(c) such Special Members, being Chiefs, as may be selected by the Governor, acting in accordance with the advice of the Premier ; and

(d) four members selected by the Governor, acting in accordance with the advice of the Premier, to represent the interests of groups of persons resident in the special areas within the meaning of subsection (4) of section 14 of this Constitution, being groups whose interests, in the opinion of the Governor acting as aforesaid, are not represented by members of the House of Assembly for constituencies in those areas.

(2) A person shall not be a member of the House of Chiefs by virtue of paragraph (a) of subsection (1) of this section during any period when he holds office as Governor ; and the number of persons who are for the time being members of that House by virtue of that paragraph or paragraph (c) of that subsection shall not in the aggregate exceed ten.

(3) The seat of a member of the House of Chiefs shall become vacant—

(a) in the case of a member other than the Oba of Benin, the Olu of Warri or a Special Member, in such circumstances as may be prescribed by the Legislature of the Region ; and

(b) in the case of a Special Member, if he is removed from office as such a member by the Governor, acting in accordance with the advice of the Premier.

(4) In this section "Chief" means any person who is for the time being recognised as a Chief under any law in force in the Region.

6. Without prejudice to the provisions of subsection (5) of section 10 and subsection (13) of section 33 of this Constitution, the House of Assembly shall consist of sixty-five members.

Composition of House of Assembly.

7.—(1) Subject to the provisions of subsection (3) of this section and section 8 of this Constitution, a person shall be qualified to be a member of the House of Assembly if he is a citizen of Nigeria who has attained the age of twenty-one years and—

Qualifications for membership of House of Assembly.

(a) who was born in the Region ; or

(b) whose father was born in the Region ; or

(c) who has resided in the Region for a continuous period of at least one year immediately before the relevant date.

(2) In subsection (1) of this section "the relevant date" means—

(a) in relation to an elected member, the date of his nomination for election as a member ; and

(b) in relation to a person nominated for election as Speaker from outside the House, the date of the nomination.

(3) A law made by the Legislature of the Region may provide that, notwithstanding that a person satisfies any of the requirements of paragraphs (a) to (c) of subsection (1) of this section, he shall not be qualified to be a member of the House of Assembly for a constituency in a special area within the meaning of subsection (4) of section 14 of this Constitution unless he satisfies such conditions as may be specified by that law ; and until provision to the contrary is made by such a law there shall, as respects the constituencies in each area described in paragraphs 1, 2, 3 and 4 of the first column of the First Schedule to this Constitution, be deemed to be specified by such a law which so provides the condition that a person shall be a member in accordance with customary law of the ethnic group specified as respects that area in the second column of that Schedule.

(4) Subsection (5) of the said section 14 shall apply to a law made for the purposes of the last foregoing subsection as it applies to a law made for the purposes of subsection (4) of that section.

Disqualifications for membership of House of Assembly, etc.

8.—(1) No person shall be qualified for election to the House of Assembly—

(a) if he has voluntarily acquired citizenship of a country other than Nigeria or has, except in such cases as may be prescribed by the Legislature of the Region, made a declaration of allegiance to such a country;

(b) if under any law in force in any part of Nigeria he is adjudged to be a lunatic or otherwise declared to be of unsound mind;

(c) if he is under a sentence of death imposed on him by any court of law in Nigeria or a sentence of imprisonment (by whatever name called) exceeding six months imposed upon him by such a court or substituted by competent authority for some other sentence imposed upon him by such a court;

(d) if he is an undischarged bankrupt, having been adjudged or otherwise declared to be bankrupt under any law in force in any part of Nigeria;

(e) save as otherwise provided by the Legislature of the Region, if he is a member of the public service of the Region, the public service of the Federation or the public service of another Region, a member of the armed forces of the Federation or the holder of any other office of emolument under the state; or

(f) if he is a member of the House of Chiefs, an ex-officio member of the Senate or a member of a legislative house of another Region.

(2) The Legislature of the Region may provide that a person shall not be qualified for membership of the House of Assembly for such period (not exceeding five years) as may be prescribed if he is convicted by any court of law in Nigeria of such offences connected with the selection or election of members of a Legislative House of the Region, a House of Parliament or a legislative house of another Region as may be prescribed.

(3) The Legislature of the Region may provide that a person disqualified under paragraph (c) of subsection (1) of this section by reason of his being under a sentence of imprisonment exceeding six months for any such offence (being an offence that appears to that Legislature to involve dishonesty) as may be prescribed or by reason of his being under sentences of imprisonment that include such a sentence for any such offence shall not be qualified for membership of the House of Assembly for such period from the date on which he ceases to be disqualified under that paragraph (not exceeding five years) as may be prescribed.

(4) The Legislature of the Region may provide that a person who is the holder of any office the functions of which involve responsibility for or in connection with the conduct of any election to the House of Assembly or the compilation of any register of voters for the purposes of such an election shall not be qualified for election to that House.

(5) The Legislature of the Region may, in order to permit any person who has been adjudged to be a lunatic, declared to be of unsound mind, sentenced to death or imprisonment or adjudged or declared bankrupt to appeal against the decision in accordance with any law in force in Nigeria, provide that, subject to such conditions as may be prescribed, the decision shall not have effect for the purposes of subsection (1) of this section for such time as may be prescribed.

(6) For the purposes of paragraph (c) of subsection (1) of this section, two or more sentences of imprisonment that are required to be served consecutively shall be regarded as separate sentences if none of those sentences exceeds six months, but if any one of those sentences exceeds that term shall be regarded as one sentence.

(7) For the purposes of paragraph (e) of subsection (1) of this section, the office of President of the House of Chiefs, Deputy President or a member of that House, the Speaker or Deputy Speaker of the House of Assembly, or a member of that House, the President, Deputy President, Speaker or Deputy Speaker or a member of a House of Parliament or a legislative house of another Region, a Minister of the Government of the Region, a Minister of the Government of the Federation, a Minister of the Government of another Region, a Parliamentary Secretary to any such Minister, a member of the Executive Council of the Region, a member of the Council of Ministers, a member of the Executive Council of another Region, a member of the Council of Chiefs of Northern Nigeria, or a member of any such body corporate as is referred to in the proviso to subsection (10) of this section shall not be regarded as an office of emolument under the state.

(8) Save as otherwise provided by the Legislature of the Region, a person shall not be regarded as disqualified for membership of the House of Assembly by reason only that he holds office as a member of a statutory corporation.

(9) If a person who holds the office of a member of a statutory corporation becomes a member of the House of Assembly, he shall, unless it is otherwise provided by the Legislature of the Region, thereupon cease to hold office as a member of that corporation.

(10) In this section "statutory corporation" means any body corporate established directly by any law in force in Nigeria :

Provided that it does not include any body corporate established by virtue of the provisions of the Western Region Local Government Law, 1952, or the Local Government Law of that Region (a), as amended, or any law replacing either of those laws, as those provisions have effect as part of the law of Mid-Western Nigeria.

9.—(1) There shall be a President of the House of Chiefs, who shall be elected by the members of that House.

President of  
House of  
Chiefs.

(2) No person shall be elected as President of the House of Chiefs unless he is a member of the House or a Chief qualified for selection as a member of the House.

(3) The President of the House of Chiefs shall vacate his office—

(a) if he ceases to be a member of the House otherwise than by reason of a dissolution of the Legislative Houses of the Region ;

(b) when the House first sits after any dissolution ;

(c) if he becomes a Minister of the Government of the Region, a Parliamentary Secretary to such a Minister, a Minister of the Government of the Federation or a Minister of the Government of another Region ; or

(d) if he is removed from office by a resolution of the House supported by the votes of two-thirds of all the members of the House.

Constitution of Mid-Western Nigeria

shall be transacted in the House of Chiefs (other than the office of President of the House) at any time when the office is vacant.

no subsection (3) of section 5 of this Constitution, the House of Chiefs shall be a member of the House of Chiefs subsection if he is not such a member apart from

There shall be a Speaker of the House of Assembly, who shall be elected by the members of that House.

no person shall be elected as Speaker of the House of Assembly unless he is a member of the House or a person qualified to be a member of the House.

The Speaker of the House of Assembly shall vacate his office—  
 (a) if he ceases to be a member otherwise than by reason of the dissolution of the Legislative Houses of the Region ;

(b) when the House first sits after any dissolution ;  
 (c) if he becomes a Minister of the Government of the Region, a Parliamentary Secretary to such a Minister, a Minister of the Government of the Federation or a Minister of the Government of another Region ; or

(d) if he is removed from office by a resolution of the House supported by the votes of two-thirds of all the members of the House.

(4) No business shall be transacted in the House of Assembly (other than an election to the office of Speaker) at any time when that office is vacant.

(5) Subject to the provisions of section 12 of this Constitution, the Speaker shall be a member of the House of Assembly by virtue of this subsection if he is not such a member apart from this subsection.

11.—(1) A Minister of the Government of the Region may attend and take part in the proceedings of either Legislative House of the Region notwithstanding that he is not a member of that House.

(2) Nothing in this section shall entitle any person who is not a member of a Legislative House of the Region to vote in that House or in any of its committees.

are of  
 3 of  
 members of  
 House of  
 Assembly.

12.—(1) A member of the House of Assembly shall vacate his seat in the House—

(a) if he becomes a member of the House of Chiefs, a House of Parliament or a legislative house of another Region ;

(b) if any other circumstances arise that, if he were not a member of the House, would cause him to be disqualified for election as such under subsection (1), (2) or (3) of section 8 of this Constitution ;

(c) if he ceases to be a citizen of Nigeria ;

(d) if he becomes a Minister of the Government of the Federation or a Minister of the Government of another Region ;

(e) save as otherwise provided by the Legislature of the Region, if he becomes a member of any statutory corporation ; or

(f) if he is absent from the House of Chiefs and the Speaker of the House of Chiefs excuses his absence from a meeting.

(2) The Legislature shall be a lunatic, declared to be insane or adjudged to be insane in accordance with such conditions as may be prescribed for the purposes of this subsection.

(3) In this section the expression "lunatic" shall have the meaning assigned to it in the law.

13.—(1) The

(2) The

(a) the

(b) the

(c) the

(3) the

Legisla

of th

the J

mer

Fed

E

v

(f) if he is absent from two consecutive meetings of the House and the Speaker of the House does not, by writing under his hand, excuse his absence within one month after the end of the second meeting.

(2) The Legislature of the Region may, in order to permit any member of the House of Assembly who has been adjudged to be a lunatic, declared to be of unsound mind, sentenced to death or imprisonment or adjudged or declared bankrupt to appeal against the decision in accordance with any law in force in Nigeria, provide that, subject to such conditions as may be prescribed, the decision shall not have effect for the purposes of this section until such time as may be prescribed.

(3) In this section the expression "statutory corporation" has the meaning assigned to it for the purposes of section 8 of this Constitution.

13.—(1) There shall be an Electoral Commission for the Region.

(2) The members of the Electoral Commission of the Region shall be—

(a) the chairman of the Electoral Commission of the Federation, who shall be chairman ;

(b) the member of the Electoral Commission of the Federation representing the Region ; and

(c) two other members or such greater number of members as may be appointed by the Governor, acting in accordance with the advice of the Premier.

(3) A person shall not be qualified for appointment as a member of the Electoral Commission of the Region if he is a member of either Legislative House of the Region, a member of either House of Parliament or a member of a legislative house of another Region, a Minister of the Government of the Region, a Minister of the Government of the Federation, a Minister of the Government of another Region or a member of the public service of the Region, the public service of the Federation or the public service of another Region.

(4) Subject to the provisions of this section, a member of the Electoral Commission of the Region appointed by the Governor shall vacate his office—

(a) at the expiration of five years from the date of his appointment ;  
or

(b) if any circumstances arise that, if he were not a member of the Commission, would cause him to be disqualified for appointment as such a member.

(5) A member of the Electoral Commission of the Region appointed by the Governor may be removed from office by the Governor, acting in accordance with the advice of the Premier, for inability to discharge the functions of his office (whether arising from infirmity of mind or body or any other cause) or for misbehaviour.

(6) A member of the Electoral Commission of the Region appointed by the Governor shall not be removed from office except in accordance with the provisions of this section.

(7) In the exercise of its functions under this Constitution the Electoral Commission of the Region shall not be subject to the direction or control of any other person or authority.

Establishment of Electoral Commission.

Consti-  
tuencies.

14.—(1) The Region shall be divided into as many constituencies as there are members of the House of Assembly by virtue of section 6 of this Constitution, and shall be so divided in such manner as the competent authority, acting with the approval of each Legislative House of the Region signified by resolution, may prescribe.

(2) The boundaries of each constituency shall be such that the number of inhabitants thereof is as nearly equal to the population quota as is reasonably practicable :

Provided that the number of inhabitants of a constituency may be greater or less than the population quota in order to take account of means of communication, geographical features and the distribution of different communities.

(3) The competent authority shall review the division of the Region into constituencies at intervals of not less than eight and not more than ten years and may alter the constituencies in accordance with the provisions of this section to such extent as it may consider desirable in the light of the review :

Provided that that authority may at any time carry out such a review and alter the constituencies in accordance with the provisions of this section to such extent as it considers necessary in consequence of any alteration of the boundaries of the Region or by reason of the holding of a census of the population of the Region in pursuance of any law in force in the Region.

(4) Notwithstanding anything in the foregoing provisions of this section, each of the special areas within the meaning of this subsection shall be divided into four constituencies in the manner mentioned in subsection (1) of this section ; but the constituencies established in pursuance of this subsection shall be included in, and shall not be additional to, the total number of constituencies established in pursuance of the said subsection (1).

In this and the next following subsection, "special areas" mean such areas within the Region (not for the time being exceeding four) as may be specified for the purposes of this subsection by a law made by the Legislature of the Region ; and until provision to the contrary is made by such a law, the areas described in paragraphs 1, 2, 3 and 4 respectively of the first column of the First Schedule to this Constitution shall each be deemed to be specified as aforesaid.

(5) A law made by the Legislature of the Region for the purposes of subsection (4) of this section shall not come into force as respects any existing special area unless—

(a) a referendum upon the question whether the law should come into force has been held in that area in pursuance of provision made in that behalf by the Legislature of the Region ; and

(b) the persons entitled to vote in the referendum were those who at the date of the referendum were entitled to vote in elections of members of the House of Assembly for the constituencies in that area ; and

(c) not less than two-thirds of all those persons voted in the referendum in favour of the law.

(6) Where the boundaries of any constituency established in pursuance of this section are altered in accordance with the provisions

of this section, that alteration shall come into effect upon the next following dissolution of the Legislative Houses of the Region.

(7) In this section "population quota" means the number obtained by dividing the number of the inhabitants of the Region by the number of constituencies into which the Region is divided in pursuance of this section, any constituency established in pursuance of subsection (4) of this section and the inhabitants of any such constituency being left out of account.

(8) For the purposes of this section the number of inhabitants of the Region or a constituency shall be ascertained by reference to the latest census of the population of the Region held in pursuance of any law in force in the Region.

(9) In this section "the competent authority" means the Electoral Commission of the Region or such other authority consisting of persons appointed by the Governor, acting in accordance with the advice of the Premier, as may be established in that behalf by the Legislature of the Region.

15.—(1) Every constituency established in pursuance of section 14 of this Constitution shall return to the House of Assembly one member who shall be directly elected in such manner as may be prescribed by the Legislature of the Region. Elections.

(2) The registration of voters at elections to the House of Assembly and the conduct of such elections shall be subject to the direction and supervision of the Electoral Commission of the Region.

16.—(1) The High Court of the Region shall have original jurisdiction to hear and determine any question whether—  
 (a) any person has been validly selected or elected as a member of a legislative House of the Region ; or  
 (b) the seat in a Legislative House of any member of that House has become vacant. Determination of questions of membership of Legislative Houses.

(2) The Legislature of the Region may make provision with respect to—

(a) the persons who may apply to the High Court of the Region for the determination of any question under this section ;

(b) the circumstances and manner in which, and the conditions upon which, any such application may be made ; and

(c) the powers, practice and procedure of the High Court in relation to any such application.

17.—(1) There shall be a Clerk to the House of Chiefs and a Clerk to the House of Assembly, and both offices may be held by the same person. Clerks to Legislative Houses and their staffs.

(2) Subject to the provisions of any Regional law, the office of the Clerk of each Legislative House of the Region and the office of each member of his staff shall be offices in the public service of the Region.

#### Part II.—Procedure in Legislative Houses

18. Every member of either Legislative House of the Region shall, before taking his seat in that House, take and subscribe before the House the oath of allegiance, but a member may before taking that oath take part in the election of a President of the House of Chiefs or a Speaker of the House of Assembly, as the case may be : Oaths to be taken by members of Legislative Houses.

Provided that if a Legislative House is not sitting a member of that House may take and subscribe the oath of allegiance before a judge of the High Court of the Region.

Presiding in  
House of  
Chiefs.

19.—(1) There shall preside at any sitting of the House of Chiefs—

(a) the President of the House ; or

(b) in the absence of the President of the House, the Deputy President ; or

(c) in the absence of the President of the House and the Deputy President, such member of the House as the House may elect for that purpose.

(2) The House of Chiefs may from time to time elect a member of the House to be Deputy President and any person so elected shall hold office as such until he ceases to be a member of the House or is removed from office by the House.

Presiding in  
House of  
Assembly.

20.—(1) There shall preside at any sitting of the House of Assembly—

(a) the Speaker ; or

(b) in the absence of the Speaker, the Deputy Speaker ; or

(c) in the absence of the Speaker and the Deputy Speaker, such member of the House as the House may elect for that purpose.

(2) The House of Assembly may from time to time elect a member of the House to be Deputy Speaker and any person so elected shall hold office as such until he ceases to be a member of the House or is removed from office by the House.

Quorum in  
Legislative  
Houses.

21. If objection is taken by any member of a Legislative House of the Region present that there are present in that House (besides the person presiding) fewer than one-sixth of all the members of that House and, after such interval as may be prescribed in the rules of procedure of the House, the person presiding ascertains that the number of members present is still less than one-sixth of all the members of the House, he shall thereupon adjourn the House.

Use of  
English in  
Legislative  
Houses.

22. The business of the Legislative Houses of the Region shall be conducted in English.

Voting in  
Legislative  
Houses.

23.—(1) Any question proposed for decision in a Legislative House of the Region shall be determined by the required majority of the members present and voting ; and the person presiding shall cast a vote whenever necessary to avoid an equality of votes but shall not vote in any other case.

(2) Save as otherwise provided in this Constitution, the required majority for the purposes of determining any question shall be a simple majority.

(3) The rules of procedure of a Legislative House of the Region may provide that the vote of a member upon a question in which he has a direct pecuniary interest shall be disallowed.

24. Any person who sits or votes in either Legislative House of the Region knowing or having reasonable ground for knowing that he is not entitled to do so shall be liable to a penalty not exceeding twenty pounds or such other sum as may be prescribed by the Legislature of the Region for each day on which he sits or votes in that House, which shall be recoverable by action in the High Court of the Region at the suit of the Attorney-General of the Region.

Unqualified persons sitting or voting.

25.—(1) The power of the Legislature of the Region to make laws shall be exercised by bills passed by both Legislative Houses of the Region (or in the cases mentioned in section 27 of this Constitution the House of Assembly) and assented to by the Governor.

Mode of exercising legislative power.

(2) A bill other than a money bill may originate in either Legislative House of the Region but a money bill may originate only in the House of Assembly.

(3) When a bill has been passed by the Legislative House of the Region in which it originated, it shall be sent to the other House; and it shall be presented to the Governor for assent—

(a) when it has been passed by the other House and agreement has been reached between the two Houses on any amendments made in it; or

(b) when it is required to be so presented under section 27 of this Constitution.

(4) When a bill is presented to the Governor for assent, he shall signify that he assents or that he withholds assent.

(5) A bill shall not become law unless it has been duly passed and assented to in accordance with this Constitution.

26.—(1) The House of Chiefs shall not—

(a) proceed upon any bill, other than a bill sent from the House of Assembly, that, in the opinion of the person presiding, makes provision for any of the following purposes—

Restrictions with regard to certain financial measures.

(i) the imposition, repeal or alteration of taxation;

(ii) the imposition of any charge upon the Consolidated Revenue Fund or any other public fund of the Region;

(iii) the payment, issue or withdrawal from the Consolidated Revenue Fund or any other public fund of the Region of any moneys not charged thereon or any alteration in the amount of such a payment, issue or withdrawal; or

(iv) the composition or remission of any debt due to the Region;

(b) proceed upon any amendment to any bill that, in the opinion of the person presiding, makes provision for any of those purposes;

(c) proceed upon any motion (including any amendment to a motion) the effect of which, in the opinion of the person presiding, would be to make provision for any of those purposes; or

(d) receive any petition that, in the opinion of the person presiding, requests that provision be made for any of those purposes.

(2) Except upon the recommendation of the Governor signified by a Minister of the Government of the Region, the House of Assembly shall not—

(a) proceed upon any bill (including any amendment to a bill) that, in the opinion of the person presiding, makes provision for any of the following purposes—

(i) the imposition of taxation or the alteration of taxation otherwise than by reduction ;

(ii) the imposition of any charge upon the Consolidated Revenue Fund or any other public fund of the Region or the alteration of any such charge otherwise than by reduction ;

(iii) the payment, issue or withdrawal from the Consolidated Revenue Fund or any other public fund of the Region of any moneys not charged thereon or any increase in the amount of such a payment, issue or withdrawal ; or

(iv) the composition or remission of any debt due to the Region ;

(b) proceed upon any motion (including any amendment to a motion) the effect of which, in the opinion of the person presiding, would be to make provision for any of those purposes ; or

(c) receive any petition that, in the opinion of the person presiding, requests that provision be made for any of those purposes.

Limitation  
of powers of  
House of  
Chiefs.

27.—(1) Where a money bill is passed by the House of Assembly and, having been sent to the House of Chiefs at least one month before the end of the session, is not passed by the House of Chiefs without amendment within one month after it is so sent, the bill shall, unless the House of Assembly otherwise resolves, be presented to the Governor for his assent.

(2) Where—

(a) a bill that is not a money bill is passed by the House of Assembly and, having been sent to the House of Chiefs at least one month before the end of the session, is not passed by the House of Chiefs before the end of the session or is passed by the House of Chiefs with amendments to which the House of Assembly does not before the end of the session agree ; and

(b) in the following session (whether of the same Legislative Houses or not) but not earlier than six months after it was first passed by the House of Assembly the same bill, with no other alterations than those mentioned in subsection (4) of this section, is passed again by the House of Assembly and sent to the House of Chiefs at least one month before the end of the session and is not passed by the House of Chiefs before the end of the session or is passed by the House of Chiefs with amendments to which the House of Assembly does not before the end of the session agree,

the bill shall, unless the House of Assembly otherwise resolves, be presented to the Governor for his assent with such amendments, if any, as may have been agreed to by both Houses.

(3) The House of Assembly may, on the passage of a bill for the purposes of paragraph (b) of subsection (2) of this section, suggest any amendments without inserting the amendments in the bill and any such suggested amendments shall be considered by the House of Chiefs and, if agreed to by the House of Chiefs, shall be treated as amendments agreed to by both Houses ; but the exercise of this power by the House of Assembly shall not affect the operation of this section if the bill is not passed by the House of Chiefs or is passed by the House of Chiefs with amendments to which the House of Assembly does not agree.

(4) The alterations referred to in subsection (2) of this section are alterations certified by the Speaker of the House of Assembly to be necessary owing to the time that has elapsed since the bill was passed in the earlier session or to represent amendments made in that session by the House of Chiefs.

(5) When a money bill is sent to the House of Chiefs from the House of Assembly it shall bear a certificate of the Speaker of the House of Assembly that it is a money bill.

(6) When a bill is presented to the Governor in pursuance of this section it shall bear a certificate of the Speaker of the House of Assembly that this section has been complied with and that certificate shall be conclusive for all purposes and shall not be questioned in any court of law.

(7) This section does not apply to any bill for the purposes of section 5 of the Constitution of the Federation.

28.—(1) Subject to the provisions of this Constitution, each Legislative House of the Region may regulate its own procedure.

Regulation  
of procedure  
in Legislative  
Houses.

(2) Each Legislative House of the Region may act notwithstanding any vacancy in its membership (including any vacancy not filled when the House first meets after any dissolution), and the presence or participation of any person not entitled to be present at or to participate in the proceedings of the House shall not invalidate those proceedings.

29. Without prejudice to the generality of section 75 of this Constitution, in this Part of this Chapter "money bill" means a bill that in the opinion of the Speaker of the House of Assembly contains only provisions dealing with—

Interpreta-  
tion of Part  
II.

(a) the imposition, repeal, remission, alteration or regulation of taxation ;

(b) the imposition for the payment of debt or other financial purposes of charges on the Consolidated Revenue Fund or any other public fund of the Region or the variation or repeal of any such charges;

(c) the grant of money to the state or to any other person or authority or the variation or revocation of any such grant ;

(d) the appropriation, receipt, custody, investment, issue or audit of accounts of public money ;

(e) the raising or guarantee of any loan or the repayment thereof ; or

(f) subordinate matters incidental to any of those matters :

Provided that the expressions "taxation", "public money" and "loan" do not include any taxation, money or loan raised by local authorities or bodies for public purposes.

*Part III.—Summoning, prorogation and dissolution*

Sessions of  
Legislative  
Houses.

30. Each session of the Legislative Houses of the Region shall be held at such place within the Region and shall begin at such time (not being later than twelve months from the end of the preceding session if those Houses have been prorogued or three months from the end of that session if those Houses have been dissolved) as the Governor shall appoint.

Prorogation  
and dissolution  
of  
Legislative  
Houses.

31.—(1) The Governor may at any time prorogue or dissolve the Legislative Houses of the Region.

(2) Subject to the provisions of subsection (3) of this section, the Legislative Houses of the Region, unless sooner dissolved, shall continue for five years from the date of their first sitting after any dissolution and shall then stand dissolved.

(3) At any time when the Federation is at war, the Legislature of the Region may from time to time extend the period of five years specified in subsection (2) of this section for not more than twelve months at a time :

Provided that the life of the Legislative Houses of the Region shall not be extended under this subsection for more than five years.

(4) In the exercise of his powers to dissolve the Legislative Houses of the Region the Governor shall act in accordance with the advice of the Premier, so however that if the Premier recommends a dissolution in a case not falling within subsection (5) of this section and the Governor considers that the government of the Region can be carried on without a dissolution and that a dissolution would not be in the interests of the Region, he may refuse to dissolve the Legislative Houses.

(5) The Governor shall dissolve the Legislative Houses of the Region—

(a) if the House of Assembly passes a resolution that it has no confidence in the Government of the Region, and within the period of three days beginning with the day on which the resolution is passed the Premier does not resign or recommend a dissolution or does recommend a dissolution ;

(b) if the office of Premier is vacant and the Governor considers that there is no prospect of his being able, within a reasonable time, to appoint to that office a person who can command the support of the majority of the members of the House of Assembly.

## CHAPTER III

## EXECUTIVE POWERS

32.—(1) The executive authority of the Region shall be vested in the Governor and, subject to the provisions of this Constitution, may be exercised by him either directly or through officers subordinate to him. Exercise of executive authority of Region.

(2) Nothing in this section shall prevent the Legislature of the Region from conferring functions on persons or authorities other than the Governor.

33.—(1) There shall be a Premier of the Region, who shall be appointed by the Governor. Ministers of Government of Region.

(2) Whenever the Governor has occasion to appoint a Premier he shall appoint a member of the House of Assembly who appears to him likely to command the support of the majority of the members of the House.

(3) There shall be, in addition to the office of Premier, such other offices of Minister of the Government of the Region as may be established by this Constitution or by the Legislature of the Region or, subject to the provisions of any Regional law, by the Governor, acting in accordance with the advice of the Premier.

(4) Appointments to the office of Minister of the Government of the Region other than the office of Premier shall be made by the Governor, acting in accordance with the advice of the Premier :

Provided that at least two Ministers shall be appointed from among the members of the House of Chiefs.

(5) A person shall not hold office at the same time both as a Minister of the Government of the Region and as a Minister of the Government of the Federation or as a Minister of the Government of another Region.

(6) A person who holds office as a Minister of the Government of the Region for any period of four consecutive months without also being a member of a Legislative House of the Region shall cease to be a Minister at the expiration of that period or, if that period expires at a time when the Legislative Houses are dissolved and he does not in the meantime become a member of a Legislative House, at the date on which the Legislative Houses first meet after that dissolution.

(7) A person who holds office as a Minister of the Government of the Region and who is at no time while holding that office also a member of a Legislative House of the Region shall not be qualified for re-appointment as such a Minister before the Legislative Houses are next dissolved after he ceases to hold that office, unless in the meantime he has become a member of a Legislative House.

(8) The office of the Premier shall become vacant—

(a) when, after any dissolution of the Legislative Houses of the Region, the Premier is informed by the Governor that the Governor is about to reappoint him as Premier or to appoint another person as Premier ; or

(b) if he ceases to be a member of the House of Assembly otherwise than by reason of a dissolution of the Legislative Houses.

(9) The office of a Minister of the Government of the Region other than the Premier shall become vacant if the office of Premier becomes vacant.

(10) Subject to the provisions of subsection (9) of this section, the Ministers of the Government of the Region, other than the Premier, shall hold office during the Governor's pleasure; but the Governor shall not remove such a Minister from office except in accordance with the advice of the Premier.

(11) If on any occasion the office of Premier becomes vacant at a time when the Legislative Houses of the Region are dissolved, then—

(a) subsections (2) and (9) of this section and paragraph (b) of subsection (2) of section 40 of this Constitution shall not apply as respects that occasion; and

(b) the Governor shall appoint a member of the Executive Council as the Premier;

and if a dissolution of the Legislative Houses of the Region takes place at a time when the office of Premier is vacant, the Governor shall, without regard to the provisions of subsection (2) of this section, appoint as Premier a person who was a member of the Executive Council immediately before the vacancy occurred.

(12) There shall be an Attorney-General of the Region who shall be a Minister of the Government of the Region.

(13) Subject to the provisions of section 12 of this Constitution, the Attorney-General of the Region shall be a member of the House of Assembly by virtue of this subsection if he is not a member of the House of Chiefs and is not apart from this subsection a member of the House of Assembly.

(14) If the person holding the office of Attorney-General of the Region is for any reason unable to perform the functions conferred upon him by this Constitution or any other law, those functions (other than functions as a member of the House of Assembly) may be performed by such other person, whether or not that person is a Minister, as may from time to time be designated in that behalf by the Governor, acting in accordance with the advice of the Premier.

(15) A person shall not be qualified to hold or perform the functions of the office of the Attorney-General of the Region unless he is qualified for admission as an advocate in Nigeria and has been so qualified for not less than ten years.

Establish-  
ment of  
Executive  
Council.

34.—(1) There shall be an Executive Council for the Region, whose function shall be to advise the Governor in the government of the Region and which shall consist of the Premier and such other persons, being Ministers of the Government of the Region, as the Governor, acting in accordance with the advice of the Premier, may from time to time appoint.

(2) A person appointed as a member of the Executive Council shall vacate his seat on the Council if he ceases to be a Minister of the Government of the Region or if the Governor, acting in accordance with the advice of the Premier, so directs.

35.—(1) The Executive Council shall be collectively responsible to the Legislative Houses of the Region for any advice given to the Governor by or under the general authority of the Council and for all things done by or under the authority of any Minister of the Government of the Region in the execution of his office.

Collective responsibility.

(2) The provisions of this section shall not apply in relation to—

(a) the appointment and removal from office of Ministers of the Government of the Region, members of the Executive Council and Parliamentary Secretaries to Ministers, the assignment of portfolios to Ministers or the authorization of another member of the Executive Council to perform the functions of the Premier in pursuance of section 37 of this Constitution ;

(b) the dissolution of the Legislative Houses of the Region ;

(c) the matters referred to in section 44 of this Constitution ; or

(d) the exercise of the powers conferred on the Attorney-General of the Region by section 47 of this Constitution.

36. The Governor, acting in accordance with the advice of the Premier, may assign to the Premier or any other Minister of the Government of the Region responsibility for any business of the Government of the Region, including the administration of any department of government.

Allocation of portfolios to Ministers.

37.—(1) Whenever the Premier is absent from Nigeria or is for any other reason unable to perform the functions conferred upon him by this Constitution, the Governor may authorize some other member of the Executive Council of the Region to perform those functions (other than the functions conferred by this section) and that member may perform those functions until his authority is revoked by the Governor.

Performance of functions of Premier during absence, etc.

(2) The powers of the Governor under this section shall be exercised by him in accordance with the advice of the Premier :

Provided that if the Governor considers that it is impracticable to obtain the advice of the Premier owing to his absence or illness he may exercise those powers without that advice.

38.—(1) Subject to the provisions of subsection (2) of this section, in the exercise of his functions under this Constitution, the Constitution of the Federation or any other law the Governor shall act in accordance with the advice of the Executive Council or a Minister of the Government of the Region acting under the general authority of the Executive Council except in cases where by this Constitution he is required to act in accordance with the advice of any person or authority other than the Executive Council :

Exercise of Governor's powers.

Provided that the Governor shall act in accordance with his own deliberate judgment in the performance of the following functions—

(a) in the exercise of the power to refuse to dissolve the Legislative Houses of the Region conferred upon him by subsection (4) of section 31 of this Constitution ;

(b) in the exercise of the powers to appoint the Premier conferred upon him by subsections (2) and (11) of section 33 of this Constitution and of the power conferred upon him by subsection (8) of that section to inform the Premier of his re-appointment or replacement ;

(c) in the exercise of the powers conferred upon him by section 37 of this Constitution in the circumstances described in the proviso to subsection (2) of that section ;

(d) in the exercise of the power conferred upon him by section 39 of this Constitution to request the Premier to furnish him with information ; and

(e) in signifying his approval for the purposes of section 62 of this Constitution of an appointment to an office on his personal staff.

(2) Nothing in subsection (1) of this section shall apply to functions conferred upon the Governor by subsection (5) of section 31, subsection (2) of section 50 or subsection (3) of section 67 of this Constitution.

(3) Where by this Constitution the Governor is required to act in accordance with the advice of any person or authority, the question whether he has in any case received, or acted in accordance with, such advice shall not be enquired into in any court of law.

Governor to be informed concerning matters of government.

39. The Premier shall keep the Governor fully informed concerning the general conduct of the government of the Region and shall furnish the Governor with such information as he may request with respect to any particular matter relating to the government of the Region.

Parliamentary Secretaries.

40.—(1) The Governor, acting in accordance with the advice of the Premier, may appoint Parliamentary Secretaries from among the members of the Legislative Houses of the Region to assist Ministers of the Government of the Region in the performance of their duties.

(2) The office of a Parliamentary Secretary shall become vacant—

(a) if he ceases to be a member of one or other of the Legislative Houses of the Region otherwise than by reason of a dissolution of those Houses ;

(b) if the office of Premier becomes vacant ; or

(c) if the Governor, acting in accordance with the advice of the Premier, so directs.

Oaths to be taken by Ministers,

41. A member of the Executive Council, Minister of the Government of the Region or Parliamentary Secretary to such a Minister shall not enter upon the duties of his office unless he has taken and subscribed the oath of allegiance and such oath for the due execution of his office as may be prescribed by the Legislature of the Region.

42. Where any Minister of the Government of the Region has been charged with responsibility for any department of government, he shall exercise general direction and control over that department; and, subject to such direction and control, the department shall be under the supervision of a permanent secretary, whose office shall be an office in the public service of the Region :

Permanent secretaries.

Provided that two or more government departments may be placed under the supervision of one permanent secretary.

43. Subject to the provisions of this Constitution and of any Regional law, the Governor may constitute offices for the Region, make appointments to any such office and terminate any such appointment.

Constitution of offices for Region, etc.

44.—(1) The Governor may—

Prerogative of mercy.

(a) grant to any person concerned in or convicted of any offence created by or under a Regional law a pardon, either free or subject to lawful conditions ;

(b) grant to any person a respite, either indefinite or for a specified period, of the execution of any punishment imposed on that person for such an offence ;

(c) substitute a less severe form of punishment for any punishment imposed on that person for such an offence ; or

(d) remit the whole or any part of any punishment imposed on that person for such an offence or of any penalty or forfeiture otherwise due to the state on account of such an offence.

(2) The powers of the Governor under subsection (1) of this section shall be exercised by him in accordance with the advice of such member of the Executive Council as may from time to time be designated in that behalf by the Governor, acting in accordance with the advice of the Premier.

(3) The provisions of this section shall apply in relation to any offence created by or under any law in force in the Region relating to any matter not included in the Legislative Lists set out in the Schedule to the Constitution of the Federation (other than an offence created by or under an Act of Parliament or a Regional law) as they apply in relation to an offence created by or under a Regional law.

45.—(1) There shall be for the Region an Advisory Council on the Prerogative of Mercy, which shall consist of—

Establishment of Advisory Council on Prerogative of mercy.

(a) such member of the Executive Council as may for the time being be designated under subsection (2) of section 44 of this Constitution, who shall be chairman ;

(b) where the chairman is a Minister other than the Attorney-General of the Region, the Attorney-General ; and

(c) not less than five nor more than seven other members, who shall be appointed by the Governor, acting in accordance with the advice of the Premier, of whom at least one shall be a person who is a qualified medical practitioner.

(2) A person shall not be qualified for appointment by the Governor as a member of the Advisory Council if he is a member of a Legislative House of the Region, a member of either House of Parliament, a member of a legislative house of another Region, a Minister of the Government of the Region, a Minister of the Government of the Federation or a Minister of the Government of another Region.

(3) A member of the Advisory Council appointed by the Governor shall hold office for three years :

Provided that his seat on the Council shall become vacant—

(a) if any circumstances arise that, if he were not a member of the Council, would cause him to be disqualified for appointment as such a member ; or

(b) if he is removed from office by the Governor, acting in accordance with the advice of the Premier, for inability to discharge the functions of his office (whether arising from infirmity of mind or body or any other cause) or for misbehaviour.

Functions of  
Advisory  
Council.

46.—(1) Where any person has been sentenced to death by any court of law in Nigeria for any offence created by or under a Regional law the member of the Executive Council of the Region designated under subsection (2) of section 44 of this Constitution shall cause a written report of the case from the trial judge, together with such other information derived from the record of the case or elsewhere as the member may require, to be taken into consideration at a meeting of the Advisory Council ; and after obtaining the advice of the Council the member shall decide in his own deliberate judgment whether to recommend to the Governor that he should exercise any of his powers under that section in relation to that person.

(2) The member of the Executive Council designated under subsection (2) of section 44 of this Constitution may consult the Advisory Council before making any recommendation to the Governor under that subsection in any case not falling within subsection (1) of this section, but he shall not be obliged to act in accordance with the advice of the Council.

(3) The Advisory Council may regulate its own procedure.

Public  
prosecu-  
tions.

47.—(1) There shall be a Director of Public Prosecutions for the Region, whose office shall be an office in the public service of the Region and, without prejudice to the provisions of this Constitution relating to the Public Service Commission of the Region, an office in the department of government for which responsibility is assigned to the Attorney-General of the Region.

(2) The Attorney-General of the Region shall have power in any case in which he considers it desirable so to do—

(a) to institute and undertake criminal proceedings against any person before any court of law in the Region in respect of any offence created by or under any Regional law ;

(b) to take over and continue any such criminal proceedings that may have been instituted by any other person or authority ; and

(c) to discontinue at any stage before judgment is delivered any such criminal proceedings instituted or undertaken by himself or any other person or authority.

(3) The powers of the Attorney-General of the Region under subsection (2) of this section may be exercised by him in person and through the Director of Public Prosecutions of the Region acting under and in accordance with the general or special instructions of the Attorney-General and through other officers of the department mentioned in subsection (1) of this section acting under and in accordance with such instructions.

(4) The Attorney-General of the Region may confer a general or special authority upon the Attorney-General of the Federation to exercise, subject to such conditions and exceptions as he may think fit, any of the powers conferred upon him by subsection (2) of this section and may vary or revoke any such authority.

(5) The powers conferred upon the Attorney-General of the Region by paragraphs (b) and (c) of subsection (2) of this section shall be vested in him to the exclusion of any other person or authority :

Provided that where any other person or authority has instituted criminal proceedings, nothing in this subsection shall prevent the withdrawal of those proceedings by or at the instance of that person or authority at any stage before the person against whom the proceedings have been instituted has been charged before the court.

(6) In the exercise of the powers conferred upon him by this section the Attorney-General of the Region shall not be subject to the direction or control of any other person or authority.

(7) For the purposes of this section any appeal from any determination in any criminal proceedings before any court of law in the Region or any case stated or question of law reserved for the purposes of any such proceedings to any other court in Nigeria shall be deemed to be part of those proceedings.

(8) The provisions of this section shall apply in relation to any offence created by or under any law in force in the Region relating to any matter not included in the Legislative Lists set out in the Schedule to the Constitution of the Federation (other than an offence created by or under an Act of Parliament or a Regional law) as they apply in relation to an offence created by or under a Regional law.

(9) Except at the instance of the Attorney-General of the Region, the question whether he has given any instructions in pursuance of this section, or what the instructions were, shall not be enquired into by any court of law.

## CHAPTER IV

### COURTS

48.—(1) There shall be a High Court for the Region.

(2) The judges of the High Court of the Region shall be—

(a) the Chief Justice of the Region ; and

(b) such number of other judges (not being less than six) as may be prescribed by the Legislature of the Region.

Establish-  
ment of High  
Court.

(3) The High Court of the Region shall be a superior court of record and, save as otherwise provided by any law in force in the Region, shall have all the powers of such a court.

Appointment  
of judges of  
High Court.

49.—(1) The Chief Justice of the Region and the other judges of the High Court of the Region shall be appointed by the Governor, acting in accordance with the advice of the Premier.

(2) A person shall not be qualified to hold the office of a judge of the High Court of the Region unless—

(a) he is or has been a judge of a court having unlimited jurisdiction in civil and criminal matters in some part of the Commonwealth or a court having jurisdiction in appeals from any such court ; or

(b) he is qualified for admission as an advocate in Nigeria and he has been so qualified for not less than ten years.

(3) If the office of Chief Justice of the Region is vacant or if the person holding the office is for any reason unable to perform the functions of his office, then, until a person has been appointed to and has assumed the functions of that office or until the person holding the office has resumed those functions, as the case may be, those functions shall be performed by such one of the other judges of the High Court of the Region as may from time to time be designated in that behalf by the Governor, acting in accordance with the advice of the Premier.

(4) If the office of any judge of the High Court of the Region other than the Chief Justice is vacant or if the person holding the office is acting as Chief Justice or is for any reason unable to perform the functions of his office, the Governor, acting in accordance with the advice of the Premier, may appoint a person with such qualifications as may be prescribed by the Legislature of the Region to act in the office of a judge of the High Court and any person so appointed shall continue to act for the period of his appointment or if no period is specified until his appointment is revoked by the Governor, acting in accordance with the advice of the Premier.

Tenure of  
offices of  
judges of  
High Court.

50.—(1) Subject to the provisions of this section, a person holding or appointed to act in the office of Chief Justice of the Region or any other judge of the High Court of the Region shall vacate his office when he attains such age as may be prescribed by the Legislature of the Region :

Provided that the Governor, acting in accordance with the advice of the Premier, may permit a judge to continue in his office or appointment for such period after attaining that age as may be necessary to enable him to deliver judgment or to do any other thing in relation to proceedings that were commenced before him before he attained that age.

(2) A person holding or appointed to act in the office of a judge of the High Court of the Region shall be removed from his office or appointment by the Governor if—

(a) there are presented to the Governor addresses from both Legislative Houses of the Region praying that that person be so removed for inability to discharge the functions of the office in question (whether arising from infirmity of mind or body or any other cause) or for misbehaviour ; and

(b) the address from each House bears a certificate which is signed by the person who presided at the meeting of that House at which the motion for the address was passed and which states that not less than two-thirds of all the members of that House voted in favour of the motion ;

and, except on the revocation in pursuance of section 49 of this Constitution of an appointment to act as aforesaid, a person holding or appointed to act in such an office shall not be removed from his office or appointment in any other circumstances.

51.—(1) An appeal shall lie from decisions of a subordinate court to the High Court of the Region as of right or, if it is provided by any law in force in the Region that an appeal as of right shall lie from that subordinate court to another subordinate court, an appeal shall thereafter lie to the High Court as of right in the following cases—

Appeals to High Court from subordinate courts.

(a) where the matter in dispute on the appeal to the High Court is of the value of fifty pounds or upwards or where the appeal involves directly or indirectly a claim to or question respecting property or a right of the value of fifty pounds or upwards, final decisions in any civil proceedings ;

(b) where the ground of appeal to the High Court involves questions of law alone, decisions in any criminal proceedings in which any person has been sentenced to imprisonment for a term exceeding three months or corporal punishment exceeding six strokes or a fine or forfeiture exceeding twenty-five pounds by the subordinate court from which the appeal lies to the High Court or that subordinate court has affirmed or substituted such a sentence ;

(c) decisions in any civil or criminal proceedings on questions as to the interpretation of this Constitution, the Constitution of the Federation or the constitution of another Region ;

(d) decisions in any civil or criminal proceedings on questions as to whether any of the provisions of Chapter III of the Constitution of the Federation has been contravened in relation to any person ;

(e) decisions in any criminal proceedings in which any person has been sentenced to death by the subordinate court from which the appeal lies to the High Court or in which that subordinate court has affirmed a sentence of death ;

(f) decisions in any other criminal proceedings before a subordinate court sitting at first instance from which no appeal lies as of right to another subordinate court ; and

(g) such other cases as may be prescribed by any law in force in the Region :

Provided that no appeal shall lie from decisions of a subordinate court established under section 126 of the Constitution of the Federation to the High Court in any case in which an appeal lies as of right to the Supreme Court by virtue of any Act of Parliament enacted in pursuance of section 118 of that Constitution.

(2) An appeal shall lie from decisions of a subordinate court to the High Court of the Region with the leave of the High Court or, if it is provided by any law in force in the Region that an appeal shall lie from that subordinate court to another subordinate court, an appeal shall thereafter lie to the High Court with the leave of the High Court in the following cases :—

(a) decisions in any criminal proceedings from which no appeal lies as of right to the High Court ; and

(b) such other cases in which no appeal lies as of right to the High Court as may be prescribed by any law in force in the Region :

Provided that no appeal shall lie under paragraph (a) of this subsection from decisions of a subordinate court established under section 126 of the Constitution of the Federation to the High Court in any case in which an appeal lies to the Supreme Court (whether as of right or with the leave of the Supreme Court) by virtue of an Act of Parliament enacted under section 118 of that Constitution.

(3) Any right of appeal from decisions of a subordinate court to the High Court of the Region conferred by this section—

(a) shall be exercisable in the case of civil proceedings at the instance of a party thereto or, with the leave of the High Court, at the instance of any other person having an interest in the matter and in the case of criminal proceedings at the instance of the accused person or, subject to the provisions of section 47 of this Constitution, at the instance of such other persons or authorities as may be prescribed by any law in force in the Region ; and

(b) shall be exercised in accordance with any laws and rules of court for the time being in force regulating the powers, practice and procedure of the High Court.

(4) In this section—

“decision” means, in relation to a subordinate court, any determination of that court and, without prejudice to the generality of the foregoing provisions of this definition, includes a judgment, decree, order, conviction, sentence (other than a sentence fixed by law) or recommendation ;

“subordinate court” means any court of law in the Region other than the Supreme Court, the Court of Appeal of the Region, the High Court of the Region or a court-martial.

Power to  
establish  
Regional  
Court of  
Appeal.

52.—(1) The Legislature of the Region may establish a Court of Appeal for the Region to which appeals shall lie from the High Court of the Region in such circumstances as the Legislature of the Region may prescribe.

(2) The provisions of this Constitution relating to the Chief Justice of the Region and any other judge of the High Court of the Region (other than sections 2 and 18) shall apply with the necessary modifications in relation to the principal and any other judge respectively of the Court of Appeal as they apply in relation to a judge of the High Court of the Region, so however that the Legislature of the Region may provide that a person shall not hold or act in the office of a judge of the Court of Appeal unless he has such qualifications additional to those specified by the provisions aforesaid as the Legislature may prescribe.

53. A judge of the High Court of the Region shall not enter upon the duties of his office unless he has taken and subscribed the oath of allegiance and such oath for the due execution of his office as may be prescribed by the Legislature of the Region.

Oaths to be taken by judges.

## CHAPTER V

### FINANCE

54.—(1) All revenues or other moneys raised or received by the Region (not being revenues or other moneys payable under this Constitution or any Regional law into some other public fund of the Region established for a specific purpose) shall be paid into and form one Consolidated Revenue Fund.

Establishment of Consolidated Revenue Fund.

(2) No moneys shall be withdrawn from the Consolidated Revenue Fund of the Region except to meet expenditure that is charged upon the Fund by this Constitution, the Constitution of the Federation or any Regional law or where the issue of those moneys has been authorised by an appropriation law or a law made in pursuance of section 56 of this Constitution.

(3) No money shall be withdrawn from any public fund of the Region other than the Consolidated Revenue Fund unless the issue of those moneys has been authorised by a Regional law.

(4) No money shall be withdrawn from the Consolidated Revenue Fund or any other public fund of the Region except in the manner prescribed by the Legislature of the Region.

55.—(1) The Minister of the Government of the Region responsible for finance shall cause to be prepared and laid before both Legislative Houses of the Region in each financial year estimates of the revenues and expenditure of the Region for the next following financial year.

Authorization of expenditure from Consolidated Revenue Fund.

(2) The heads of expenditure contained in the estimates (other than expenditure charged upon the Consolidated Revenue Fund by this Constitution, the Constitution of the Federation or any Regional law) shall be included in a bill, to be known as an appropriation bill, providing for the issue from the Consolidated Revenue Fund of the Region of the sums necessary to meet that expenditure and the appropriation of those sums for the purposes specified therein.

(3) If in respect of any financial year it is found—

(a) that the amount appropriated by the appropriation law for any purpose is insufficient or that a need has arisen for expenditure for a purpose for which no amount has been appropriated by the law ; or

(b) that any moneys have been expended for any purpose in excess of the amount appropriated for the purpose by the appropriation law or for a purpose for which no amount has been appropriated by the law,

a supplementary estimate showing the sums required or spent shall be laid before both Legislative Houses of the Region and the heads of any such expenditure shall be included in a supplementary appropriation bill.

Authoriza-  
tion of  
expenditure  
in advance of  
appropria-  
tion.

56. The Legislature of the Region may make provision under which, if the appropriation law in respect of any financial year has not come into operation by the beginning of that financial year, the Minister of the Government of the Region responsible for finance may authorize the withdrawal of moneys from the Consolidated Revenue Fund of the Region for the purpose of meeting expenditure necessary to carry on the services of the Government until the expiration of four months from the beginning of that financial year or the coming into operation of the appropriation law, whichever is the earlier.

Contingen-  
cies Fund.

57.—(1) The Legislature of the Region may provide for the establishment of a Contingencies Fund for the Region and for authorising the Minister of the Government of the Region responsible for finance, if satisfied that there has arisen an urgent and unforeseen need for expenditure for which no other provision exists, to make advances from the Fund to meet that need.

(2) Where any advance is made in accordance with subsection (1) of this section a supplementary estimate shall be presented and a supplementary appropriation bill shall be introduced as soon as possible for the purpose of replacing the amount so advanced.

Remunera-  
tion of  
Governor  
and certain  
other  
officers.

58.—(1) There shall be paid to the holders of the offices mentioned in subsection (4) of this section such salary as may be prescribed by the Legislature of the Region.

(2) The salary and allowances payable to the holders of the offices so mentioned shall be a charge on the Consolidated Revenue Fund of the Region.

(3) The salary payable to the holder of any office so mentioned and his terms of office other than allowances shall not be altered to his disadvantage after his appointment.

(4) The offices aforesaid are the office of Governor, Chief Justice or other judge of the High Court of the Region, member of the Electoral Commission of the Region appointed by the Governor, member of the Public Service Commission of the Region and Director of Audit of the Region.

Audit of  
public  
accounts.

59.—(1) There shall be a Director of Audit for the Region, whose office shall be an office in the public service of the Region.

(2) The public accounts of the Region and of all offices, courts and authorities of the Region shall be audited and reported on by the Director of Audit of the Region, and for that purpose the Director or any person authorised by him in that behalf shall have access to all books, records, returns and other documents relating to those accounts.

(3) The Director of Audit of the Region shall submit his reports to the Minister of the Government of the Region responsible for finance, who shall cause them to be laid before both Legislative Houses of the Region.

(4) In the exercise of his functions under this Constitution the Director of Audit of the Region shall not be subject to the direction or control of any other person or authority.

Public debt.

60.—(1) The public debt of the Region shall be secured on the revenues and assets of the Region.

(2) In this section references to the public debt of the Region include references to the interest on that debt, sinking fund payments in respect of that debt and the costs, charges and expenses incidental to the management of that debt.

## CHAPTER VI

### THE PUBLIC SERVICE OF THE REGION

61.—(1) There shall be a Public Service Commission for the Region, which shall consist of a chairman and not less than two nor more than four other members.

Establishment of Public Service Commission.

(2) The members of the Public Service Commission of the Region shall be appointed by the Governor, acting in accordance with the advice of the Premier.

(3) A person shall not be qualified to hold the office of a member of the Public Service Commission of the Region if he is a member of a Legislative House of the Region, a member of a House of Parliament, a member of a legislative house of another Region, a Minister of the Government of the Region, a Minister of the Government of the Federation, a Minister of the Government of another Region or a member of the public service of the Region, the public service of the Federation or the public service of another Region.

(4) Subject to the provisions of this section, a member of the Public Service Commission of the Region shall vacate his office—

(a) at the expiration of five years from the date of his appointment; or

(b) if any circumstances arise that, if he were not a member of the Commission, would cause him to be disqualified for appointment as such.

(5) A member of the Public Service Commission of the Region may be removed from office by the Governor, acting in accordance with the advice of the Premier, for inability to discharge the functions of his office (whether arising from infirmity of mind or body or any other cause) or for misbehaviour.

(6) A member of the Public Service Commission of the Region shall not be removed from office except in accordance with the provisions of this section.

(7) A person who has been appointed to be a member of the Public Service Commission of the Region shall not thereafter be eligible for appointment to any office in the public service of the Region.

62.—(1) Power to appoint persons to hold or act in offices in the public service of the Region (including power to make appointments on promotion and transfer and to confirm appointments) and to dismiss and exercise disciplinary control over persons holding or acting in such offices shall vest in the Public Service Commission of the Region :

Appointment etc. of officers in public service.

Provided that the Commission may, with the approval of the Premier and subject to such conditions as it may think fit, delegate any of its powers under this section to any of its members or to any officer in the public service of the Region.

(2) Subsection (1) of this section shall not apply in relation to any of the following offices—

- (a) the office of the Deputy Governor of the Region ;
- (b) the office of any judge of the High Court of the Region ;
- (c) except for the purposes of making an appointment thereto, the office of the Director of Audit of the Region ;
- (d) the office of the Agent-General of the Region in the United Kingdom ;
- (e) the office of justice of the peace.

(3) The provisions of this section shall be subject to the provisions of section 65 of this Constitution.

(4) No appointment shall be made under this section to any office on the personal staff of the Governor unless the Governor signifies his approval of the appointment.

Appointment etc. of Deputy Governor.

63. If at any time the office of Deputy Governor of the Region is established under section 43 of this Constitution, power to appoint persons to hold or act in that office and to remove persons so appointed from that office shall vest in the Governor, acting in accordance with the advice of the Premier.

Appointment etc. of Agent-General in U.K.

64.—(1) Power to appoint persons to hold or act in the office of the Agent-General of the Region in the United Kingdom (including power to make appointments on promotion and transfer) and to remove persons so appointed from that office shall vest in the Governor, acting in accordance with the advice of the Premier.

(2) Before tendering any advice for the purposes of this section in relation to any person who holds any office in the public service of the Region other than an office to which this section applies, the Premier shall consult the Public Service Commission of the Region.

Appointment etc. of permanent secretaries.

65.—(1) Power to appoint persons to hold or act in the office of permanent secretary to any department of government of the Region and to remove persons so appointed from that office shall vest in the Governor, acting in accordance with the advice of the Premier.

(2) Before tendering any advice for the purposes of this section the Premier shall consult the Public Service Commission of the Region.

Qualifications of Director of Public Prosecutions.

66. A person shall not be qualified to hold or act in the office of Director of Public Prosecutions of the Region unless he is qualified for admission as an advocate in Nigeria and has been so qualified for not less than ten years.

Appointment and tenure of office of Director of Audit.

67.—(1) Before appointing any person to hold the office of Director of Audit of the Region the Public Service Commission of the Region shall consult the Premier.

(2) Subject to the provisions of this section, a person holding the office of Director of Audit of the Region shall vacate that office when he attains such age as may be prescribed by the Legislature of the Region.

(3) A person holding the office of Director of Audit of the Region shall be removed from office by the Governor if a resolution is passed by each Legislative House of the Region recommending his removal

from office for inability to discharge the functions of his office (whether arising from infirmity of body or mind or any other cause) or for misbehaviour.

(4) A person holding the office of Director of Audit of the Region shall not be removed from office except in accordance with the provisions of this section.

(5) If the office of Director of Audit of the Region is vacant or the holder of the office is for any reason unable to perform the functions of the office, the Public Service Commission of the Region, acting after consultation with the Premier, may appoint a person to act in the office and any person so appointed shall continue to act until his appointment is revoked by the Commission, acting after consultation with the Premier.

68. Before exercising any of its powers in relation to the Clerk to the House of Chiefs the Public Service Commission of the Region shall consult the President of that House, and before exercising any of its powers in relation to the Clerk to the House of Assembly the Commission shall consult the Speaker of that House.

Powers relating to Clerks of Legislative Houses.

69.—(1) Where any benefits to which this section applies can be withheld, reduced in amount or suspended by any person or authority under any Regional law, those benefits shall not be so withheld, reduced in amount or suspended without the approval of the Public Service Commission of the Region.

Powers of Commissions in relation to grant of pensions, etc.

(2) No benefits to which this section applies that have been granted to any person who holds or has held the office of judge of the High Court of the Region or for which any such person may be eligible shall be withheld, reduced or suspended on the ground that that person has been guilty of misbehaviour while holding that office unless that person has been removed from that office by reason of such misbehaviour.

(3) This section applies to any benefits payable under any Regional law providing for the grant of pensions, gratuities or compensation to persons who are or have been members of the public service of the Region in respect of their service in that public service or to the widows, children, dependants or personal representatives of such persons in respect of such service.

## CHAPTER VII

### MISCELLANEOUS

70. Power to appoint persons to hold the office of justice of the peace for the Region or any part thereof and to remove or suspend persons so appointed from that office shall vest in the Attorney-General of the Region.

Appointment of justices of the peace.

71.—(1) Any Commission established by this Constitution may, with the consent of the Premier or such other Minister of the Government of the Region as may be authorised in that behalf by the Premier, by regulation or otherwise regulate its own procedure or confer powers and impose duties on any officer or authority of the Region for the purpose of discharging its functions.

Powers and procedure of Commissions.

(2) Subject to its rules of procedure, any Commission established by this Constitution may act notwithstanding any vacancy in its membership or the absence of any member, but any decision of the Commission shall require the concurrence of a majority of all the members thereof.

Establishment of provincial administrations.

72.—(1) The Governor may by order designate any area within the Region as a province and establish for it a provincial administration.

(2) A provincial administration established under this section shall consist of such persons and shall have such functions as may be prescribed by the Governor or by any law in force in the Region.

(3) The provisions of this section shall be without prejudice to the powers of the Legislature of the Region to establish a provincial administration for any area within the Region or otherwise to make provision for the administration of such an area.

Resignations.

73.—(1) Any person who is appointed or elected to or otherwise selected for any office established by this Constitution may resign from that office by writing under his hand addressed to the person or authority by whom he is appointed, elected or selected :

Provided that—

(a) in the case of the Governor of the Region, his resignation shall be addressed to the Premier ;

(b) in the case of a member of a Legislative House of the Region who holds office as President or Speaker of the House, his resignation from the House or that office shall be addressed to the House ; and

(c) in the case of any other member of a Legislative House of the Region, his resignation from the House shall be addressed to the President or Speaker of the House, as the case may be.

(2) The resignation of any person from any office established by this Constitution shall take effect when the writing signifying the resignation is received by the person or authority to whom it is addressed or by any person authorised by that person or authority to receive it.

(3) On the resignation of the Governor of the Region, the Premier shall forthwith give notice of the resignation to the President.

Re-appointments, etc.

74.—(1) Where any person has vacated any office constituted by this Constitution, he may, if qualified, again be appointed, elected or otherwise selected to hold that office in accordance with the provisions of this Constitution.

(2) Where by this Constitution a power is conferred upon any person or authority to make any appointment to any office in the public service of the Region, a person may be appointed to that office, notwithstanding that some other person may be holding that office, when that other person is on leave of absence pending relinquishment of his office ; and where two or more persons are holding the same office by reason of an appointment made in pursuance of this subsection, then for the purpose of any function conferred upon the holder of that office, the person last appointed shall be deemed to be the sole holder of the office.

75.—(1) In this Constitution, unless it is otherwise expressly provided or required by the context—

Interpretation, etc.—  
general.

“Act of Parliament” means any law made by Parliament ;

“the Advisory Council” means the Advisory Council on the Prerogative of Mercy of the Region ;

“the Commonwealth” means Nigeria, any country to which section 14 of the Constitution of the Federation applies and any dependency of any such country ;

“financial year” means any period of twelve months beginning on the first day of April in any year or such other date as the Legislature of the Region may prescribe ;

“oath” includes affirmation ;

“the oath of allegiance” means such oath of allegiance as may be prescribed by Parliament ;

“Parliament” means the Parliament of the Federation ;

“the President” means the President of the Republic ;

“the public service of the Region” means the service of the Republic in a civil capacity in respect of the government of the Region ;

“Regional law” means any law made by the Legislature of the Region ;

“the state” means the Government of the Federation or a Region and “office under the state” and “office of emolument under the state” include office as the Governor of a Region or as a member of the Government of the Federation or a Region, so however that a person shall not be treated as holding an office of emolument under the state by reason only of his receiving a pension or other like benefit in respect of an office under the state ; and

“the Supreme Court” means the Supreme Court of Nigeria.

(2) In this Constitution, unless it is otherwise expressly provided or required by the context—

(a) references to persons holding offices in the public service of the Federation or the public service of a Region include references to persons acting in those offices ; and

(b) references to offices in the public service of the Region include references to the offices of the judges of the High Court of the Region and references to the offices of members of all other courts of law established by the Legislature of the Region, being offices the emoluments attaching to which are paid out of the Consolidated Revenue Fund or any other public fund of the Region.

(3) For the purposes of this Constitution, the office of the President of the House of Chiefs or the Deputy President of the House, a member of the House of Chiefs, the Speaker or the Deputy Speaker of the House of Assembly, a member of the House of Assembly, a Minister of the Government of the Region, a Parliamentary Secretary to such a Minister or a member of the Executive Council, any Commission established by this Constitution or the Advisory Council or a justice of the peace for the Region shall not be regarded as an office in the public service of the Region.

(3) Nothing in this Constitution shall be construed as affecting the jurisdiction of the High Court of Western Nigeria as respects such pending proceedings as are mentioned in the said section six.

*Vesting of property, etc.*

4.—(1) All property held by the Administrative Council of Mid-Western Nigeria immediately before the appointed day shall, by virtue of this sub-paragraph and without further assurance, vest in the Governor of the Region on that day and be held by him for the purposes of the government of the Region.

(2) The foregoing sub-paragraph shall, with the necessary modifications, apply in relation to rights, liabilities and obligations arising out of a contract or other arrangement as it applies in relation to property.

*Finance*

5.—(1) The assets of the Mid-Western Region Administration Fund shall be paid into, and any sums falling to be paid from that fund shall be defrayed out of, the Consolidated Revenue Fund of the Region.

(2) Any regulations having effect by virtue of subsection (3) of section eight of the Transitional Provisions Act immediately before the appointed day shall, until varied or revoked by virtue of a law made by the Legislature of the Region, continue to have effect by virtue of this sub-paragraph but as if for any reference in the regulations to the administration fund aforesaid there were substituted a reference to the Consolidated Revenue Fund of the Region.

(3) The duty imposed by subsection (1) of section 55 of this Constitution as respects estimates for the financial year beginning on the first day of April, 1964, shall be treated as duly performed if it is performed before the expiration of that financial year; and section 56 of this Constitution shall have effect, in relation to that financial year, as if for the words "four months" there were substituted the words "twelve months".

*Operation of existing law*

6.—(1) Any law which, immediately before the appointed day, is in force in or in any part of the Region by virtue of section two, three or four of the Transitional Provisions Act shall, until it is changed by an authority having power to do so and subject to paragraph 5 of this Schedule, continue in force in the Region or part with such modifications (whether by way of addition, alteration or omission) as may be necessary to bring it into conformity with this Constitution.

(2) Without prejudice to the provisions of the foregoing sub-paragraph, where any matter—

(a) falls to be prescribed under this Constitution by the Legislature of the Region or any other authority; and

(b) is prescribed by any law having effect by virtue of that sub-paragraph or paragraph 5 of this Schedule,

that law shall, as respects that matter, be deemed to have been made by the Legislature or other authority in question.

(3) For the avoidance of doubt it is hereby declared that the provisions repealed by section 154 of the Constitution of the Federation ceased to have effect as respects the Region on the coming into force of that Constitution, and accordingly nothing in sub-paragraph (1) of this paragraph shall be construed as continuing those provisions in force as respects the Region.

(4) For the purposes of subsection (1) of section three of the Constitution of Mid-Western Nigeria Act, 1964, but not for any other purposes, the reference in this paragraph to the appointed day shall be construed as a reference to the relevant date mentioned in that subsection.

#### *Existing public authorities and officers*

7.—(1) The Administrative Council of Mid-Western Nigeria is hereby abolished on the appointed day.

(2) Without prejudice to the provisions of paragraph 6 of this Schedule, every local authority, court or other public body which, immediately before the appointed day, is charged with functions in the Region by virtue of subsection (1) of section five of the Transitional Provisions Act shall, until other provision in that behalf is made by law, continue to be charged with those functions.

(3) Any person who, immediately before the appointed day, holds office by virtue of subsection (2) of the said section five shall be deemed to be duly appointed to that office on that day by the Public Service Commission of the Region or, as the case may be, by any other authority by whom appointments to that office fall to be made in pursuance of this Constitution.

#### *Miscellaneous*

8. In relation to a Legislative House of the Region which has never been dissolved, subsection (2) of section 31 of this Constitution shall have effect as if the words "after any dissolution" were omitted.

9. In this Schedule—

"the appointed day" means, subject to sub-paragraph (4) of paragraph 6 of this Schedule, the day appointed in pursuance of subsection (3) of section three of the Constitution of Mid-Western Nigeria Act, 1964;

"functions" includes powers and duties; and

"the Transitional Provisions Act" means the Mid-Western Region (Transitional Provisions) Act, 1963.



## JUSTICES OF THE SUPREME COURT ACT, 1964



---

 1964, No. 4

AN ACT TO INCREASE THE NUMBER OF THE JUSTICES OF THE SUPREME COURT.

[20th January, 1964]

Commence-  
ment.

BE IT ENACTED by the Legislature of the Federation of Nigeria in this present Parliament assembled and by the authority of the same as follows :—

- |   |  |
|---|--|
| <p>1. The number of the Justices of the Supreme Court shall be increased by three ; and accordingly, in subsection (1) of section three of the Federal Supreme Court Act, 1960 (which provides that the number of those Justices shall be five), for the word "five" there shall be substituted the word "eight".</p> | <p>Increase in number of justices.<br/>No. 12 of 1960.</p> |
| <p>2. This Act may be cited as the Justices of the Supreme Court Act, 1964, and shall apply throughout the Federation.</p>  | <p>Short title and extent.</p>                             |

(5) A warrant under this section may provide that the warrant shall have effect as if it had been made on such date (not being earlier than the day when this Act is deemed to have come into force) as may be specified by the warrant ; and an honour for which provision is made by a warrant and which was awarded in accordance with subsection (4) of this section before the making of the warrant but on or after the date so specified shall be deemed to have been awarded in pursuance of the warrant.

(6) Nothing in this section shall be construed as authorising provision to be made by warrant with respect to the dignity of a chief.

Offences.

2. If a person who is not entitled in pursuance of a warrant under this Act to a particular honour or rank of an honour for which provision is made by the warrant—

(a) uses a designation or abbreviation specified by the warrant in respect of the honour or rank or a description so nearly resembling such a designation or abbreviation as to be likely to deceive ; or

(b) wears or otherwise uses any insignia so specified or an emblem so nearly resembling any such insignia as to be likely to deceive ; or

(c) by any other means represents himself to be a person who is or was entitled to the honour or rank,

he shall be guilty of an offence and liable on summary conviction to imprisonment for a term not exceeding six months or a fine of an amount not exceeding fifty pounds or both.

3.—(1) This Act may be cited as the National Honours Act, 1964, and shall apply throughout the Federation.

(2) This Act shall be deemed to have come into force on the first day of October, 1963.

Short title,  
extent and  
commence-  
ment.



## 1964, No. 6

## AN ACT TO AMEND THE ELECTORAL ACT, 1962.

[20th January, 1964]

Commence-  
ment.

BE IT ENACTED by the Legislature of the Federation of Nigeria in this present Parliament assembled and by the authority of the same as follows :—

1. In subsection (1) of section six of the principal Act (which provides that the first register of electors under that Act shall be compiled from a preliminary list prepared from the records of the census taken on the thirteenth day of May, nineteen hundred and sixty-two), for the words "the thirteenth day of May, nineteen hundred and sixty-two" there shall be substituted the words "the fifth day of November, nineteen hundred and sixty-three"; and accordingly, in subsection (5) of that section (which requires the compilation of a new register after each census held after the year nineteen hundred and sixty-two), for the words "sixty-two" there shall be substituted the words "sixty-three".
- Alteration of reference to date of census, etc.
2. No deposit shall be payable in pursuance of section eight of the principal Act in connection with an objection to the inclusion of a name in a preliminary list; and accordingly, in subsection (2) of that section, the words from "Every notice" onwards and, in the First Schedule to that Act, paragraph 3 of Form 3 are hereby repealed.
- Abolition of deposit payable on lodging of objection.
3. The amount of the deposit payable in pursuance of section twenty of the principal Act (which requires a candidate to pay twenty-five pounds before his nomination paper is delivered to the electoral officer) shall be increased to one hundred pounds; and accordingly, in subsection (1) of that section, for the words "twenty-five" there shall be substituted the words "one hundred".
- Increase of deposit payable before nomination
- 4.—(1) A person nominated as a candidate at an election in accordance with Part II of the principal Act may, at any time before the beginning of the period of seven days ending with the date of the election, withdraw his candidature by delivering to the electoral officer a notice signed by the candidate stating that he withdraws his candidature.
- Withdrawal of candidates
- (2) An electoral officer to whom a notice is delivered in pursuance of the foregoing subsection shall forthwith cause a copy of the notice to be displayed, until the date of the election, at each place at which nomination papers may be delivered in connection with the election.

(3) The deposit paid by a candidate in pursuance of section twenty of the principal Act shall be returned to him or his personal representatives if his candidature is withdrawn in accordance with the provisions of subsection (1) of this section.

(4) Subsection (4) of section twenty-one of the principal Act (which prohibits the withdrawal of a candidate after his nomination paper is delivered to the electoral officer) is hereby repealed; and subsection (5) of that section (which relates to election petitions) shall apply to the withdrawal of a candidature in pursuance of this section as it applies to the acceptance of a nomination paper.

Removal of  
limitation  
on period  
when treat-  
ing is  
prohibited

5. The period during which the corrupt practice of treating may be committed under section eighty of the principal Act shall not be limited to the time between the dissolution of Parliament and the return of the writs or, as the case may be, between the issue and return of the writ; and accordingly, in that section, the words from "between" to "other election" and the words "during any such period" are hereby repealed.

Short title,  
and extent  
etc.

6.—(1) This Act may be cited as the Electoral Act, 1964, and shall apply throughout the Federation.

1962, No. 31.

(2) In this Act "the principal Act" means the Electoral Act, 1962; and this Act shall be construed as one with the principal Act.

**SUPPLEMENTARY APPROPRIATION  
(1963-64) ACT, 1964**

A 59



**1964, No. 7**

AN ACT TO AUTHORISE THE ISSUE OUT OF THE CONSOLIDATED REVENUE FUND OF THE SUM OF FOUR HUNDRED AND FORTY-FIVE THOUSAND, FOUR HUNDRED AND THIRTY POUNDS FOR THE PURPOSE OF REPLACING ADVANCES FROM THE CONTINGENCIES FUND AND OF MAKING FURTHER PROVISION FOR THE SERVICE OF THE YEAR ENDING ON THE THIRTY-FIRST DAY OF MARCH, ONE THOUSAND NINE HUNDRED AND SIXTY-FOUR ; AND TO APPROPRIATE THAT AMOUNT FOR THE PURPOSES SPECIFIED IN THIS ACT.

[20th January, 1964]

Commence-  
ment.

BE IT ENACTED by the Legislature of the Federation of Nigeria in this present Parliament assembled and by the authority of the same as follows :—

1. The aggregate amount mentioned in section one of the Appropriation Act, 1963 and section one of the Supplementary Appropriation (1963-64) Act, 1963 (which together provide for the issue out of the Consolidated Revenue Fund in respect of the year ending on the 31st day of March, 1964, of sums not exceeding in aggregate £58,378,130) shall be increased by four hundred and forty-five thousand, four hundred and thirty pounds ; and the additional amount shall be appropriated—

Issue and appropriation of £445,430 from Consolidated Revenue Fund for Contingencies Fund and for service of 1963-64, 1963, Nos. 2 and 18.

(a) as to three hundred and eight thousand, four hundred and thirty pounds, to the replacement of advances from the Contingencies Fund ; and

(b) as to one hundred and thirty-seven thousand pounds, to heads of expenditure as indicated in the Schedule to this Act ; and subsection (3) of section one of the Appropriation Act, 1963 (which provides for the lapse of balances outstanding at the end of the financial year) shall have effect accordingly.

2. This Act may be cited as the Supplementary Appropriation (1963-64) Act, 1964, and shall apply throughout the Federation.

Short title and extent.

Section 1

SCHEDULE

Head	Amount
	£
60 Electoral Commission .. .. .	80,000
62 Parliament .. .. .	57,000
Total .. .. .	£137,000



**SUPPLEMENTARY APPROPRIATION  
(1962-63) ACT, 1964**

A 61



**1964, No. 8**

AN ACT TO AUTHORISE THE ISSUE OUT OF THE CONSOLIDATED REVENUE FUND OF FOUR HUNDRED AND EIGHT THOUSAND AND FORTY POUNDS FOR THE PURPOSE OF MAKING FURTHER PROVISION FOR THE SERVICE OF THE YEAR WHICH ENDED ON THE THIRTY-FIRST DAY OF MARCH, ONE THOUSAND, NINE HUNDRED AND SIXTY-THREE; AND TO APPROPRIATE THAT SUM FOR THE PURPOSES SPECIFIED IN THIS ACT.

[20th January, 1964]

Commence-  
ment.

BE IT ENACTED by the Legislature of the Federation of Nigeria in this present Parliament assembled and by the authority of the same as follows :—

1. The total of the amounts mentioned in section one of the Appropriation Act, 1962, section one of the Supplementary Appropriation Act, 1962, and section one of Supplementary Appropriation (1962-63) Act, 1963 (which together provide for the issue out of the Consolidated Revenue Fund in respect of the year which ended on the 31st day of March, 1963, of sums not exceeding in aggregate £55,395,871) shall be increased by four hundred and eight thousand and forty pounds; and the additional amount shall be appropriated to heads of expenditure as indicated in the Schedule to this Act.

Issue and appropria-  
tion of  
£408,040  
from  
Consoli-  
dated  
Revenue  
Fund for  
the service  
of 1962-63.  
1962,  
Nos. 5 and  
22; 1963,  
No. 13.

2. This Act may be cited as the Supplementary Appropriation (1962-63) Act, 1964, and shall apply throughout the Federation.

Short  
title and  
extent.

Section 1

SCHEDULE

Head

Amount

									£
30 Ministry of Economic Development	..	..	..	..	..	..	..	..	204,844
33 Forestry (Research)	..	..	..	..	..	..	..	..	1,435
48 Prisons	..	..	..	..	..	..	..	..	69,428
65 Non Statutory Appropriations of Revenue	..	..	..	..	..	..	..	..	132,333
Total	..	..	..	..	..	..	..	..	£408,040





## 1964, No. 9

AN ACT TO MAKE FURTHER PROVISION FOR THE CONTROL OF EXPLOSIVES FOR THE PURPOSE OF MAINTAINING AND SECURING PUBLIC SAFETY ; AND FOR PURPOSES CONNECTED THEREWITH.

[See section 2 (3)]

BE IT ENACTED by the Legislature of the Federation of Nigeria in this present Parliament assembled and by the authority of the same as follows :

Commence-  
ment.

1.—(1) The Minister of the government of the Federation responsible for explosives may by regulations make such provision with respect to explosives as he considers expedient for the purpose of maintaining and securing public safety.

Power to  
make regu-  
lations with  
respect to  
explosives.

(2) Without prejudice to the generality of the powers conferred by the foregoing subsection, regulations made by virtue of that subsection may in particular include provision with respect to all or any of the following matters, that is to say—

- (a) the importation of explosives into Nigeria ;
- (b) the manufacture, storage, transport or use of explosives ;
- (c) the ownership or possession of explosives (including changes of ownership or possession) ;
- (d) fees in respect of licences or other instruments issued in pursuance of the regulations ;
- (e) penalties for offences against the regulations, not exceeding in the case of any particular offence imprisonment for a term of two years or a fine of five hundred pounds or both ;
- (f) the seizure of explosives in respect of which such an offence is alleged to have been or has been committed and the forfeiture of explosives in respect of which such offence has been committed.

2.—(1) This Act may be cited as the Explosives Act, 1964, and shall apply throughout the Federation.

(2) The Explosives Act and any regulations in force by virtue of that Act are hereby repealed.

(3) This Act shall come into force on such date as the said Minister may by order appoint.

Short title,  
extent, repeal  
and com-  
mencement.  
Cap. 64.





1964, No. 10

AN ACT TO PROVIDE FOR THE GRANT OF RETIREMENT BENEFITS ON THE TERMINATION OF APPROVED EMPLOYMENT AND FOR THE INCREASE OF CERTAIN PENSIONS BASED ON SUPERSEDED SCALES OF EMOLUMENTS; AND FOR PURPOSES CONNECTED WITH THE MATTERS AFORESAID. ¶

[20th January, 1964]

Commencement.

BE IT ENACTED by the Legislature of the Federation of Nigeria in this present Parliament assembled and by the authority of the same as follows :—

1.—(1) Section four of the Pensions (Statutory Corporations Service) Act (which provides for the grant of public service retirement benefits where the employment of an officer transferred to any of the corporations mentioned in that Act is terminated within three years of the establishment of the corporation) shall with the necessary modifications apply in relation to employment in approved service within the meaning of the Pensions Act as it applies in relation to such employment as aforesaid, but as if the reference to the establishment of a corporation were a reference to the commencement of the approved service in question.

Power to grant pensions etc. on termination of approved employment.

Cap. 148.  
Cap. 147.

(2) Where a person in respect of whom a pension is payable by virtue of the foregoing subsection in consequence of the termination of any approved service is subsequently employed in any capacity by a person appearing to the Minister to be the same as, or the successor to, the pensioner's former employer for the purposes of the approved service in question, the Minister may direct that payment of the pension shall not be made in respect of the period of the subsequent employment.

(3) This section shall be deemed to have come into force on the twenty-eighth day of December, 1961.

2. A pension granted after the thirty-first day of August, 1959, which—

(a) is calculated by reference to a scale of emoluments in force on or before that date; and

(b) was not increased by virtue of section three of the Pensions (Special Provisions) Act, 1961, but would have fallen to be so increased by a particular amount if it had been in payment on that date;

shall be increased by that amount with effect from the date on which the pension was granted.

Increase of pensions based on superseded scales of emoluments.  
1961,  
No. 15.

3. This Act may be cited as the Pensions Act, 1964, and shall apply throughout the Federation.

Short title and extent.



## AIR FORCE ACT, 1964



## 1964, No. 11

## ARRANGEMENT OF SECTIONS

- |   |  |
|---|--|
| <p><b>PART I—ESTABLISHMENT OF AIR FORCE</b></p> <p><i>Section</i></p> <ol style="list-style-type: none"> <li>1. Establishment, etc., of air force.</li> <li>2. Establishment of air force reserve.</li> </ol> <p><b>PART II—ESTABLISHMENT OF AIR COUNCIL</b></p> <ol style="list-style-type: none"> <li>3. Establishment of air council.</li> <li>4. Membership of air council.</li> <li>5. Powers of air council.</li> </ol> <p><b>PART III—ADMINISTRATION AND GOVERNMENT</b></p> <p style="text-align: center;"><i>Command</i></p> <ol style="list-style-type: none"> <li>6. Command of air force.</li> <li>7. Powers of command of members of co-operating army or navy units.</li> <li>8. Attachment of members of the air force to the army or navy.</li> <li>9. Attachment of personnel and powers of command.</li> <li>10. Regulations as to command.</li> </ol> <p style="text-align: center;"><i>Officers</i></p> <ol style="list-style-type: none"> <li>11. Appointment of officers.</li> <li>12. Promotion of officers, etc.</li> <li>13. Regulations as to officers.</li> </ol> <p style="text-align: center;"><i>Enlistment and Terms and Conditions of Service</i></p> <ol style="list-style-type: none"> <li>14. Recruiting officers.</li> <li>15. Enlistment.</li> <li>16. Terms of enlistment.</li> <li>17. Re-engagement and continuance in service.</li> <li>18. Prolongation of service.</li> </ol> <p style="text-align: center;"><i>Discharge and Transfer to the Reserve</i></p> <ol style="list-style-type: none"> <li>19. Discharge.</li> <li>20. Transfer to the reserve.</li> <li>21. Postponement of discharge or transfer pending proceedings for offences, etc.</li> <li>22. Right of warrant officer to discharge on reduction to ranks.</li> <li>23. Power to discharge.</li> <li>24. Right of airman to purchase discharge.</li> </ol> | <p style="text-align: center;"><i>Miscellaneous and Supplementary</i></p> <ol style="list-style-type: none"> <li>25. Rules for reckoning service.</li> <li>26. Validity of attestation and enlistment.</li> <li>27. Pensions provisions.</li> <li>28. Provisions as to death or injury.</li> <li>29. Liability for service outside Nigeria.</li> <li>30. Interpretation of, and power to make certain regulations for, this Part.</li> </ol> <p style="text-align: center;"><b>PART IV—DISCIPLINE AND TRIAL AND PUNISHMENT OF AIR FORCE OFFENCES</b></p> <ol style="list-style-type: none"> <li>31. Application.</li> </ol> <p style="text-align: center;"><i>Treachery, Cowardice and Offences arising out of air force service</i></p> <ol style="list-style-type: none"> <li>32. Aiding the enemy.</li> <li>33. Communication with the enemy.</li> <li>34. Cowardly behaviour.</li> <li>35. Offences against morale.</li> <li>36. Wilful neglect, and failure to rejoin forces, etc.</li> <li>37. Offences by or in relation to sentries, etc.</li> <li>38. Looting.</li> </ol> <p style="text-align: center;"><i>Mutiny and Insubordination</i></p> <ol style="list-style-type: none"> <li>39. Mutiny.</li> <li>40. Failure to suppress mutiny.</li> <li>41. Insubordinate behaviour.</li> <li>42. Disobedience of particular orders.</li> <li>43. Obstruction of provost officers.</li> <li>44. Disobedience of standing orders.</li> </ol> <p style="text-align: center;"><i>Desertion and Absence without Leave</i></p> <ol style="list-style-type: none"> <li>45. Desertion.</li> <li>46. Absence without leave.</li> <li>47. Assisting or concealing desertion or absence without leave.</li> <li>48. Failure to perform air force duties.</li> </ol> <p style="text-align: center;"><i>Malingering and Drunkenness</i></p> <ol style="list-style-type: none"> <li>49. Malingering.</li> <li>50. Drunkenness.</li> </ol> <p style="text-align: center;"><i>Offences relating to Property</i></p> <ol style="list-style-type: none"> <li>51. Offences in relation to public and service property.</li> <li>52. Offences in relation to property of members of forces.</li> <li>53. Miscellaneous offences relating to property.</li> </ol> |
|---|--|

ARRANGEMENT OF SECTIONS—*continued**Flying, etc., Offences*

54. Dangerous flying, etc.
55. Inaccurate certification of aircraft, etc.
56. Low flying.
57. Annoyance by flying.

*Offences relating to and by Persons in Custody*

58. Irregular arrest and confinement.
59. Permitting escape, and unlawful release of prisoners.
60. Resistance to arrest.
61. Escape from confinement.

*Offences in Relation to Courts Martial and Civil Authorities*

62. Offences in relation to courts martial.
63. False evidence.
64. Obstruction of police officer arresting officer or airman.

*Miscellaneous Offences*

65. Injurious disclosures.
66. Making false statement on enlistment.
67. Making false documents.
68. Scandalous conduct of officer.
69. Ill-treatment of officers or airmen of inferior rank.
70. Disgraceful conduct.
71. False accusation.
72. Attempts to commit air force offences.
73. Conduct to prejudice of air force discipline.

*Civil Offences*

74. Civil offences.

*Punishments*

75. Punishment of officers.
76. Punishment of warrant officers, non-commissioned officers and airmen.
77. Field punishment.

*Arrest*

78. Power to arrest offenders.
79. Provisions for avoiding delay after arrest.

*Investigation of and Summary Dealing with Charges*

80. Investigation of charges by commanding officers.
81. Charges to be dealt with summarily or by court martial.
82. Further proceedings on charges against non-commissioned officers and airmen.
83. Further proceedings on charges against officers and warrant officers.

84. Dismissal of charges referred to higher authority.
85. Officers who are to act as appropriate superior authorities and to whom commanding officers may delegate powers.

*Courts Martial**(a) General Provisions*

86. Powers of courts martial.
87. Officers having power to convene courts martial.
88. Constitution of courts martial.
89. Supplementary provisions as to constitution of courts martial.
90. Place for sitting of courts martial and adjournment to other places.

*(b) Provisions relating to Trial*

91. Challenges by accused.
92. Administration of oaths.
93. Courts martial to sit in open court.
94. Dissolution of courts martial.
95. Decisions of courts martial.
96. Finding and sentence.
97. Power to convict of offence other than that charged.
98. Rules of evidence.
99. Privilege of witnesses and others at courts martial.
100. Offences by civilians in relation to courts martial.

*(c) Confirmation, Revision and Review of Proceedings of Courts Martial*

101. Confirmation of proceedings of courts martial.
102. Petitions against finding or sentence.
103. Revision of findings of court martial.
104. Powers of confirming authority.
105. Confirming authorities.
106. Sentence of death to be approved by the President.
107. Review of findings and sentences of courts martial.
108. Reconsideration of sentences of imprisonment.

*Review of Summary Findings and Awards*

109. Review of summary findings and awards.

*Findings of Insanity, etc.*

110. Provisions where accused found insane.

ARRANGEMENT OF SECTIONS—*continued**Commencement, Suspension and Duration of Sentences*

- 111. Commencement of sentences.
- 112. Duration of sentences of imprisonment.
- 113. Air force prisoners in civil prisons.
- 114. Special provisions as to carrying out or serving of sentence outside Nigeria.
- 115. Country in which sentence of imprisonment to be served.
- 116. Duties of persons in charge of prisons and others to receive prisoners.

*Trial and Time Limit of Persons ceasing to be subject to Air Force Law*

- 117. Trial, etc., of offences although offender no longer subject to Act.
- 118. Limitation of time for trial of offences under this Act.

*Relations between Air Force and Civil Courts and Finality of Trials*

- 119. Powers of civil courts.
- 120. Offences already disposed of not to be retried.

*Inquiries*

- 121. Boards of inquiry.
- 122. Inquiries into absence.

*Miscellaneous Provisions*

- 123. Restitution or compensation for theft, etc.
- 124. Appointment of judge advocates.
- 125. Promulgation.
- 126. Custody of proceeding of courts martial and right of accused to a copy thereof.
- 127. Indemnity of prison officers, etc.

*Redress of Complaints*

- 128. Complaints by officers
- 129. Complaints by airmen.

*Rules of Procedure, etc.*

- 130. Rules of procedure and other rules.

*Interpretation of this Part*

- 131. Interpretation of Part IV.

PART V—APPEALS FROM COURTS  
MARTIAL

- 132. Right of appeal.
- 133. Procedure for applying for leave to appeal or lodging appeal.
- 134. Determination of appeals in ordinary cases.

- 135. Powers of the Supreme Court in special cases.
- 136. Appeals to be final.
- 137. Supplementary powers of the Supreme Court.
- 138. Proceedings to be heard in absence of appellants.
- 139. Defence of appeals.
- 140. Right of appellant to present his case in writing.
- 141. Suspension of death sentences.
- 142. Persons not to be tried again where conviction quashed.
- 143. Removal of prisoners for purposes of proceedings.
- 144. Furnishing, on appeal, of documents relating to trial.
- 145. Duties of registrar of the Supreme Court in respect of appeals, etc.
- 146. Rules of court.
- 147. Saving of reviewing authorities' powers.
- 148. Composition of court.
- 149. Exercise of certain powers of the Supreme Court by a Justice.
- 150. General provisions as to procedure.

PART VI—PAY, FORFEITURES  
AND DEDUCTIONS

- 151. Regulations as to pay.
- 152. Forfeitures and deductions: general provisions.
- 153. Forfeiture of pay for absence from duty.
- 154. Deductions for payment of civil penalties.
- 155. Compensation for loss occasioned by wrongful act or negligence.
- 156. Deductions for barrack damage.
- 157. Remission of forfeitures and deductions.

## PART VII—GENERAL PROVISIONS

*Exemptions for Members of Air Force*

- 158. Exemption from tolls, etc.
- 159. Exemption from taking in execution of property used for air force purposes.
- 160. Exemptions as to arms and explosives.

*Deserters and Absentees Without Leave*

- 161. Arrest of deserters and absentees without leave.
- 162. Proceedings before a civil court where persons suspected of illegal absence.
- 163. Deserters and absentees without leave surrendering to police.
- 164. Certificates of arrest or surrender.
- 165. Duties of superintendents of prisons and others to receive deserters and absentees.

ARRANGEMENT OF SECTIONS—*continued**Offences relating to Air Force  
Matters Punishable by Civil Courts*

166. Punishment for pretending to be deserter.
167. Punishment for procuring and assisting desertion.
168. Punishment for obstructing members of the air force in execution of duty.
169. Punishment for aiding malingering.
170. Unlawful purchase, etc., of air force stores.
171. Illegal dealings in documents relating to pay, pensions, mobilisation, etc.
172. Unauthorised use of, and dealing in, decorations, etc.

*Evidence*

173. Special provisions as to evidence.
174. Proof of outcome of civil trial.
175. Evidence of proceedings of court martial.

*Reductions in Rank*

176. Restriction on reduction in rank of warrant officers and non-commissioned officers.

*Miscellaneous*

177. Temporary reception into civil custody of persons under escort.
178. Avoidance of assignment of, or charge on, air force pay, pensions, etc.
179. Power of certain officers to take statutory declarations.

## PART VIII—AIR FORCE RESERVE

180. Reservists.
181. Annual training.
182. Calling out of the reserve to aid the civil power.
183. Calling out of the reserve on permanent service.
184. Punishment for non-attendance.
185. Record of illegal absence.
186. Discharge during service.
187. Regulations as to the reserve.

PART IX—APPLICATION OF THE ACT  
AND SUPPLEMENTARY PROVISIONS*Application*

188. Application of the Act.
189. Application of the Act to women.
190. Application of the Act to civilians.
191. Application of the Act to passengers.

*Wills and Distribution of Property*

192. Airman on enlistment to register the name of person entitled on his intestacy, etc.
193. Special provision relating to airmen's wills.
194. Distribution in case of deceased airman's intestacy.
195. Payment of debts of deceased airman.
196. Property of deceased airman distributed subject to rights of creditors.
197. Deceased airman's money undisposed of applied to prescribed fund.
198. Uniforms and decorations of deceased airman.
199. Application of money, etc., in case of desertion.

*Miscellaneous*

200. Power to make regulations generally.
201. Powers exercisable in subsidiary legislation.
202. Provisions as to active service.
203. Execution of orders, instruments, etc.
204. Nigerian Air Force Benefit Fund.
205. Rights of officers.
206. Application of other Acts.
207. Consequential amendments.
208. Interpretation.
209. Short title, commencement and application.

## SCHEDULES

FIRST SCHEDULE.—Alternative offences of which accused may be convicted by court martial.

SECOND SCHEDULE.—Consequential amendments.

## 1964, No. 11

AN ACT TO MAKE PROVISION FOR THE ESTABLISHMENT, GOVERNMENT AND DISCIPLINE OF THE NIGERIAN AIR FORCE AND OF AN AIR FORCE RESERVE AND TO PROVIDE FOR OTHER MATTERS CONNECTED THEREWITH OR ANCILLARY THERETO.

[See Section 209 (1)]

Commence-  
ment.

BE IT ENACTED by the Legislature of the Federation of Nigeria in this present Parliament assembled and by the authority of the same as follows :—

## PART I.—ESTABLISHMENT OF AIR FORCE

1.—(1) There shall be established and maintained in and for the Federal Republic an air force to be known as the Nigerian Air Force (in this Act referred to as “the air force”) which shall consist of such establishments as the President may from time to time think fit, and such numbers of aircraft, officers, non-commissioned officers and men as the air council as constituted under this Act may from time to time prescribe.

Establish-  
ment, etc., of  
air force.

(2) The air force shall be charged with the defence of the Federal Republic by air ; and to give effect thereto the air force shall be trained in such duties as well in the air as on the ground, as the Council of Ministers may from time to time prescribe or direct.

(3) It is hereby declared that the authority conferred by this Act to establish and maintain an air force shall include authority to raise and maintain units of or including women, and accordingly the provisions of this Act shall apply to women, subject to section one hundred and eighty-nine and to such modifications and adaptations as the President may by order specify from time to time.

(4) The air force shall not form part of the public service of the Federation.

2. There shall be established and maintained an air force reserve consisting of such numbers of officers, warrant officers, non-commissioned officers and men who are transferred to it on completion of their period of service in the air force and of such others as may be prescribed.

Establish-  
ment of air  
force reserve.

## PART II.—ESTABLISHMENT OF AIR COUNCIL

Establishment of air council.

3.—(1) Subject to the provisions of this section, there shall be established an air council to be known as the Nigerian Air Council (in this Act referred to as “the air council”) which shall be responsible under the general authority of the Minister for matters relating to the command, discipline and administration of, and of other matters relating to, the air force.

(2) Notwithstanding the provisions of the foregoing subsection, the air council shall have no responsibility for the operational use of the air force, and any such use shall, subject to overall direction by the Council of Ministers, be vested in the commander of the air force appointed under this Act.

(3) If the Prime Minister thinks it is necessary for the purpose of maintaining and securing public safety and public order he may, in any such case, and notwithstanding that directions of the Council of Ministers have not been given or obtained, give to the commander directions with respect to the operational use of the air force in Nigeria; and the commander shall comply with the directions accordingly.

Membership of air council.

4.—(1) Membership of the air council shall consist of—

- (a) the Minister, who shall be the chairman of the air council;
- (b) the Minister of State responsible for the air force;
- (c) the commander;

(d) the permanent secretary of the Ministry responsible for defence, who shall also be the secretary of the air council; and

- (e) such other persons as the Prime Minister may appoint.

(2) The chairman may from time to time nominate any member of the air council to perform the duties of the chairman at any meeting of the council at which the chairman is absent and such nomination may be either general or in respect of a particular occasion.

Powers of air council.

5. The air council may provide for all or any of the following matters—

(a) The organisation of the work of the air council and the manner in which it shall perform its functions and the duties and responsibilities of the members thereof;

(b) the delegation by notification in the Gazette to any member of the council of any of the powers or duties of the council;

(c) the consultation by the air council with persons other than members thereof; and

(d) the procedure to be followed by the air council in conducting its business.

## PART III.—ADMINISTRATION AND GOVERNMENT

*Command*

Command of the air force.

6.—(1) The President on the advice of the Prime Minister may appoint such officer (in this Act referred to as “the commander”) as he thinks fit, in whom the command of the air force and the air force reserve shall be vested; and, subject to the terms of his appointment and to any directions as to the operational use of the air force or of the air force reserve given under section three of this Act, the commander shall have the command, direction and general superintendence of the air force and of the air force reserve.

(2) The Prime Minister before tendering advice shall consult with the air council, but the question as to whether any consultation was held or what happened in the course of a consultation, shall not be enquired into by any court.

7. Insofar as powers of command depend on rank, if a member of any army or navy unit (either with or without his unit or any part of it) is acting together with any of the air force units, he shall have the like powers of a member of the air force of corresponding rank; and for the purposes of sections forty-one and seventy-eight of this Act (which relate to insubordinate behaviour and certain powers of arrest) any such member of an army or navy unit shall be treated as if he were a member of the air force of corresponding rank.

Powers of command of members of co-operating army or navy units.

8.—(1) Any member of the air force may be attached temporarily to the Army or the Navy.

Attachment of members of the air force to the army or navy.

(2) Regulations made by the appropriate service authorities may prescribe circumstances in which officers, warrant officers, non-commissioned officers and men of the air force shall be deemed to be attached to the Army or the Navy, as the case may be, under the last foregoing subsection.

(3) In this section the expression "appropriate service authorities" means—

(a) in relation to attachment to the Army, the Nigerian Army Council and the air council; and

(b) in relation to attachment to the Navy, the Nigerian Navy Board and the air council.

(4) A person shall not cease to be subject to air force law under this Act by reason only of attachment in pursuance of this section.

9.—(1) The Minister may by order direct that this section shall apply to any military, naval, or air force of a country (other than Nigeria) and where the Minister so directs the application of this section, the air council—

Attachment of personnel and powers of command.

(a) may attach temporarily to the air force any member of the foreign country to which the other force belongs; or

(b) subject to anything to the contrary in the conditions applicable to his service, may place any member of the air force of Nigeria at the disposal of the service authorities of a foreign country for the purpose of being attached temporarily by those authorities to the foreign force or force of that country.

(2) Where a member of a foreign force is by virtue of this section attached temporarily to the air force as an officer or airman as the case may be he shall, for the period of attachment, be subject to this Act to the extent to which its application to him is not modified by any order which the Minister may make under this subsection, in like manner as if he were a member of the air force of relative rank; and accordingly he shall be so treated and have like powers of command and punishment over members of the air force.

(3) When the air force and a foreign force to which this section applies are serving together whether alone or not—

(a) any member of the foreign force shall be treated and shall have over members of the air force the like powers of command as if he were a member of the air force of relative rank ; and

(b) if the forces are acting in combination, any officer of the foreign force appointed by the air council, or in accordance with regulations made by the air council, to command the combined force, or any part thereof, shall have over members of the air force the like powers of command and punishment and may be invested with the like authority to convene, and confirm the findings and sentences of, courts-martial as if he were an officer of the air force of relative rank and holding the same command.

(4) For the purposes of this section, forces shall be deemed to be serving together or acting in combination if and only if they are by order of the air council declared to be so serving or so acting ; and the relative rank of members of the air force and of the foreign force shall be such as may be prescribed by regulations made by the air council.

Regulations  
as to  
command.

10. The air council, with the approval of the Minister, may make regulations as to the persons in whom command over the establishments and units or any member thereof is vested and as to circumstances in which such command as aforesaid is to be exercised and, without prejudice to the generality of the foregoing, may in such regulations provide for the duties, functions, and powers of the commander, its air force staff and officers, warrant officers, non-commissioned officers and airmen.

### Officers

Appointment  
of officers.

11.—(1) No person shall be appointed to a commission in the air force unless he has been recommended by a board of officers set up by the air council.

(2) A person recommended for appointment to a commission in the air force shall be appointed to a commission either for an indefinite period or for a specified time.

(3) Every officer on appointment shall be issued with a commission in the form prescribed by regulations made under section thirteen of this Act and signed by the President.

(4) The appointment of a person to a commission in the air force shall be notified in the Gazette.

Promotion of  
officers, etc.

12. All promotions of officers and any retirement or resignation of an officer shall be notified in the Gazette.

Regulations  
as to  
officers.

13.—The President may make regulations governing the commissioning of officers, their terms of service, promotion, retirement, resignation and such other matters concerning officers of the air force as seem to him necessary.

### Enlistment and Terms and Conditions of Service

Recruiting  
officers.

14.—Any person authorised in that behalf by regulations made under this Part of this Act may be appointed to act as a recruiting officer and accordingly may enlist persons in the air force.

15.—(1) A person offering to enlist in the air force shall be given a notice in the prescribed form setting out questions to be answered on attestation and stating the general conditions and engagement to be entered into by him, and a recruiting officer shall not enlist any person in the air force unless satisfied by that person that he has given such a notice, understands it and wishes to be enlisted.

Enlistment .

(2) A recruiting officer shall not enlist a person under the apparent age of eighteen years unless consent to the enlistment has been given in writing by his parents or guardian or, where parents or guardian are dead or unknown, by some person approved by the administrative division of the Region or of the Federal territory, as the case may be, in which such person applying for enlistment resides.

16.—(1) The term for which a person enlisting in the air force may be enlisted shall be such a term, beginning with the date of his attestation, as is mentioned in the following provisions of this section.

Terms of enlistment.

(2) Where the person enlisting has apparently attained the age of eighteen years the term of enlistment shall, as may be prescribed, not exceed twelve years and be classed—

(a) as a term of regular service ; or

(b) as to a prescribed part, a term of regular service and as to the remainder, a term of service in the air force reserve.

(3) Where the person enlisting has not apparently attained the age of eighteen years the term shall be a term ending with the expiration of such period not exceeding twelve years as may be prescribed beginning with the date on which he attained such age, and be classed—

(a) as a term of regular service ; or

(b) as to a prescribed part, a term of regular service and as to the remainder, a term of service in the air force reserve.

17.—(1) Any airman before or after completing the term of his regular service may with the approval of the competent air force authority re-engage for such further period or periods of regular service and service in the reserve as may be prescribed :

Re-engagement and continuance in service.

Provided that—

(a) at the expiration of twelve years of continuous regular service from the date of his original attestation or the date when he apparently attained the age of eighteen years, whichever is the later, all reserve service due by him shall be deemed to have been completed ; and

(b) such further period or periods of regular service, together with the original period of regular service, shall not, except as provided by subsections (2) and (3) of this section exceed a total continuous period of twenty-four years of regular service from the date of the airman's original attestation or the date upon which he apparently attained the age of eighteen years, whichever is the later.

(2) Any airman who has completed a period of twenty-four years of regular service may, if he so desires and with the approval of the competent air force authority, continue to serve to complete thirty years of regular service in all respects as if his term of regular service was still unexpired :

Provided that—

(a) it shall be lawful for him to claim his discharge at the expiration of three months after he has given notice to his commanding officer of his wish to be discharged ; and

(b) it shall be lawful for his commanding officer to give him three months notice of intention to discharge him.

(3) Any airman who has completed a period of thirty years of regular service may, if he so desires and with the approval of the competent air force authority, continue to serve in all respects as if his regular service was still unexpired.

Prolongation  
of service.

18. Any airman whose term of regular service expires during a state of war, insurrection, hostilities or public emergency may be retained in the air force and his service prolonged for such further period as the competent air force authority, with the approval of the Minister, may direct.

#### *Discharge and Transfer to the Reserve*

Discharge.

19.—(1) Unless otherwise prescribed by this Act, if an airman becomes entitled to be discharged, he shall be discharged with all convenient speed ; but until discharged he shall remain subject to air force law under this Act.

(2) If an airman entitled to be discharged is serving out of Nigeria and his term of service is prolonged under this Act, he shall be returned to Nigeria free of cost with all convenient speed, and be discharged on his arrival in Nigeria, or if he consents to his discharge being delayed, he shall be discharged not later than six months from the date of his arrival in Nigeria.

(3) Except in pursuance of the sentence of a court martial, an airman shall not be discharged unless the discharge has been authorised by order made pursuant to regulations under this Part of this Act.

(4) Every airman shall be given on his discharge a certificate of discharge containing such particulars as may be prescribed :

Provided that an airman who is discharged within six months of the date of attestation shall not be entitled to receive a certificate of discharge.

(5) An airman who is discharged in Nigeria shall be entitled to be conveyed free of cost from the place where he is discharged to the place stated in his attestation paper to be the place where he was attested or to any place at which he intends to reside and to which he can be conveyed with no greater cost.

Transfer to  
the reserve.

20.—(1) Subject to the provisions of this Act, every airman whose term of service requires his transfer to the air force reserve shall, when so due, be transferred to that reserve ; but until he is so transferred, he shall remain subject to air force law under this Act.

(2) When an airman due for transfer to the air force reserve is serving outside Nigeria he shall be returned to Nigeria free of cost with all convenient speed and be transferred to such reserve on his arrival in Nigeria ; or, if he consents to his transfer being delayed, he shall be so transferred not later than six months from the date of his arrival in Nigeria.

(3) An airman who is transferred to the reserve in Nigeria shall be entitled to be conveyed free of cost from the place where he is transferred to the place stated in his attestation paper to be the place where he was attested or to any place at which he intends to reside and to which he can be conveyed with no greater cost.

(4) Any airman due for transfer to the air force reserve may, instead of being so transferred, be discharged forthwith by a competent air force authority without assigning any reason; and if an airman is so discharged the provisions of section nineteen of this Act (which relates to discharge) shall have effect instead of the foregoing provisions of this section.

21. Notwithstanding anything in this Part of this Act—

(a) an airman shall not be entitled to be discharged or transferred to the air force reserve at a time when he has become liable, as a person subject to service law, to be proceeded against for an offence against any of the provisions of service law:

provided that if the offence is not one for trial by court martial, this paragraph shall cease to apply;

(b) an airman who is serving a sentence of imprisonment or detention awarded by a court martial under service law, or by his commanding officer, shall not be entitled to be discharged or transferred to the air force reserve during the currency of the sentence.

Postponement of discharge or transfer pending proceedings for offences, etc.

22. Unless there exists a state of war or public emergency or there is an insurrection or hostilities have commenced, if a warrant officer is reduced to the ranks he may thereupon claim to be discharged.

Right of warrant officer to discharge on reduction to ranks.

23. An airman may be discharged by a competent air force authority at any time during his term of engagement.

Power to discharge.

24.—(1) Subject to the provisions of section eighteen of this Act (which relates to prolongation of service in times of war, etc.) an airman may claim his discharge within six months after the date of his first attestation, and if a competent air force authority approves, he shall, on payment of a sum of not more than ten pounds as may be determined by such authority, be discharged accordingly.

Right of airman to purchase discharge.

(2) Nothing in section nineteen of this Act shall apply to any such discharge, and until his discharge the airman shall remain subject to air force law under this Act.

### *Miscellaneous and Supplementary*

25.—(1) In reckoning the service of any airman for discharge or re-engagement or transfer to the air force reserve there shall be excluded therefrom—

Rules for reckoning service.

(a) all periods during which he has been absent from duty for any of the following causes—

(i) imprisonment;

(ii) desertion;

(iii) absence without leave exceeding twenty-eight days; and

(b) any period ordered by a court martial to be forfeited.

(2) Regulations under this Part of this Act may make provision for restoring service excluded by the provisions of subsection (1) of this section in consideration of good service or on other grounds justifying the restoration of service so excluded.

Validity of attestation and enlistment.

26.—(1) Where a person has upon attestation made the prescribed declaration and thereafter receives pay as an airman—

(a) the validity of his enlistment shall not be called in question on the grounds of any error or omission in his attestation paper ;

(b) after the expiration of a period of three months from the date on which he made the said declaration he shall be deemed to have been validly enlisted notwithstanding any non-compliance with the requirements of this Act or any regulations made as to enlistment or attestation or any other ground whatsoever (not being an error or omission in his attestation paper) ;

and accordingly he shall be an airman until discharged under this Act.

(2) Where a person has received pay as an airman without having previously made the prescribed declaration for enlisting he may claim his discharge at any time ; and if he makes such claim, the claim shall be submitted as soon as may be to the competent air force authority, who shall cause him to be discharged with all convenient speed. Until he is discharged, he shall be deemed to be an airman.

(3) Nothing in the foregoing provisions of this section shall be construed as prejudicing the determination of any question as to the term for which a person was enlisted or as preventing the discharge of a person who has not claimed his discharge.

Pensions provisions. Cap. 119.

27. For the purpose of the Military Pensions Act, service with the air force shall be deemed to be service in the Nigerian Army ; and accordingly the provisions of that Act shall apply in respect of members of the air force as they apply to members of the Army, but subject to such modifications as may be prescribed by the Council of Ministers.

Provisions as to death or injury. Cap. 119.

28.—(1) Every officer or airman of the air force to whom the Military Pensions Act applies who in the actual discharge of his duty and without his own default has received wounds or injuries or suffered illness shall, subject to provisions of section twenty-seven of this Act, be entitled to the like benefits under the Military Pensions Act as are accorded to members of corresponding rank in the Army.

(2) The family of any officer or airman of the air force who has been killed or has died of wounds received on active service, or who has died through illness directly attributable to fatigue or exposure incidental to such service, shall be entitled to such benefits under the Military Pensions Act as may be prescribed.

(3) For the purpose of this section “family” and “active service” shall have the respective meanings as may from time to time be assigned to those expressions by regulations made under section thirty of this Act.

Liability for service outside Nigeria.

29. The President may by order direct that any officer or airman of the air force shall proceed to any place outside Nigeria for the purpose of undergoing instruction or training or for duty or employment.

30.—(1) In this Part of this Act—

“competent air force authority” means any officer designated as such by the air council for the purposes of this Part of this Act.

(2) The air council with the approval of the Minister may make such regulations as appear to the air council to be necessary or expedient for the purpose of, or in connection with, the enlistment of recruits for the air force and generally for carrying this Part of this Act into effect. Without prejudice to the generality of the foregoing such regulations may make provision—

- (a) for prescribing the form of attestation paper to be used; and
- (b) for an oath or affirmation to be administered on enlistment.

Interpretation of, and power to make certain regulations for, this Part.

#### PART IV—DISCIPLINE AND TRIAL AND PUNISHMENT OF AIR FORCE OFFENCES

31. The provisions of this Part of this Act as to discipline and offences shall apply only to persons who, for the time being, are subject to air force law, unless the context otherwise requires.

Application.

#### *Treachery, Cowardice and Offences arising out of Air Force Service*

32.—(1) Any person, who with intent to assist the enemy—

(a) abandons or delivers up any place or post which it is his duty to defend, or induces any other person to abandon or deliver up any place or post which it is the duty of that other person to defend, or

(b) does any act calculated to imperil the success of operations of the armed forces of Nigeria, of any allied forces co-operating therewith or of any part of any of those forces, or

(c) having been made a prisoner of war, serves with or aids the enemy in the prosecution of hostilities or of measures calculated to influence morale, or in any other manner whatsoever not authorised by international usage, or

(d) furnishes the enemy with arms or ammunition or with supplies of any description, or

(e) harbours or protects an enemy not being a prisoner of war, or

(f) gives any false air signal or alters or interferes with any air signal or any apparatus for giving an air signal, or

(g) when ordered by his superior officer, or otherwise under orders, to carry out any warlike operations in the air, fails to use his utmost exertions to carry such orders into effect, or

(h) causes the capture or destruction by the enemy of aircraft belonging to the air force or any allied forces co-operating therewith, shall, on conviction by court martial, be liable to suffer death or any other punishment provided by this Act.

(2) Any person who knowingly and without lawful excuse does any of the acts specified in paragraphs (a) to (g) of subsection (1) of this section shall, where it is not proved that he acted with intent to assist the enemy, be liable on conviction by court martial to imprisonment or any less punishment provided by this Act.

Aiding the enemy.

(3) Any person who negligently causes the capture or destruction by the enemy of any of Nigerian aircraft shall, on conviction by court martial, be liable to imprisonment or any less punishment provided by this Act.

Communi-  
cation with  
the enemy.

33.—(1) Any person who, with intent to assist the enemy, communicates with or gives intelligence to the enemy shall, on conviction by court martial, be liable to suffer death or any other punishment provided by this Act.

(2) Any person who, without authority, communicates with or gives intelligence to the enemy shall, on conviction by court martial, be liable to imprisonment or any less punishment provided by this Act.

(3) In this section the expression "intelligence" means information which is or purports to be information as to any matter such that information about it would or might be directly or indirectly useful to an enemy, and in particular (but without prejudice to the generality of the foregoing provisions of this subsection) as to any matter falling within the following paragraphs, being a matter such that information as to it would or might be useful as aforesaid, that is to say—

(a) the number, description, armament, equipment, disposition, movement or condition of any of the armed forces of Nigeria or of any forces co-operating therewith, or of the ships or aircraft of any such co-operating force ;

(b) any operations or projected operations of any such forces, ships or aircraft as aforesaid ;

(c) any code, cipher, call sign, password or countersign ;

(d) any measures for the defence or fortification of any place on behalf of the government of the Federal Republic of Nigeria ;

(e) the number, description or location of any prisoners of war ;

(f) munitions of war.

Cowardly  
behaviour.

34.—(1) Any person who, when before the enemy—

(a) leaves the post, position or other place where it is his duty to be ;  
or

(b) throws away his arms, ammunition or tools, in such a manner as to show cowardice,

shall be guilty of an offence against this section.

(2) Any person who, when before the enemy, induces any other person subject to service law and before the enemy to commit an offence under subsection (1) of this section shall be guilty of an offence against this section.

(3) Any person guilty of an offence against this section shall, on conviction by court martial, be liable to imprisonment or any less punishment provided by this Act.

Offences  
against  
morale.

35. Any person who—

(a) spreads (whether orally, in writing, by signal or otherwise) reports relating to operations of any of the armed forces of Nigeria, of any forces co-operating therewith, or of any part of any of those forces, being reports calculated to create despondency or unnecessary alarm ; or

(b) when before the enemy, uses words calculated to create despondency or unnecessary alarm, shall, on conviction by court martial, be liable to imprisonment or any less punishment provided by this Act.

36.—(1) Any person who, through disobedience to orders or wilful neglect of his duty, is captured by the enemy shall be guilty of an offence against this section.

Wilful neglect and failure to rejoin forces, etc.

(2) Any person who, having been captured by the enemy, fails to take, or prevents or discourages any other person subject to service law who has been captured by the enemy from taking, any reasonable steps to rejoin the armed forces of Nigeria which are available to him or, as the case may be, to that other person shall be guilty of an offence against this section.

(3) Any person guilty of an offence against this section shall, on conviction by court martial, be liable to imprisonment or any less punishment provided by this Act.

37.—(1) Any person who, while on guard duty—

(a) sleeps at his post ; or

(b) when not on duty at a post, is asleep at a time when he is not allowed to be asleep ; or

(c) is drunk ; or

(d) leaves his post without having been regularly relieved or otherwise absents himself from any place where it is his duty to be,

shall be guilty of an offence against this section.

Offences by or in relation to sentries, etc.

(2) For the purposes of this section a person shall be treated as being drunk if owing to the influence of alcohol or any drug, whether alone or in combination with any other circumstances, he is unfit to be entrusted with his duty.

(3) Any person who strikes or otherwise uses force against any person on guard duty, being a member of any of the armed forces of Nigeria, or of any forces co-operating therewith, or by the threat of force compels any such person to let him or any other person pass, shall be guilty of an offence against this section.

(4) Any person guilty of an offence against this section shall on conviction by court martial, if the offence was not committed on active service, be liable to imprisonment for a term of not more than two years, but otherwise shall be liable to such term of imprisonment or any less punishment provided by this Act.

(5) References in this section to a person on guard duty are references to a person who—

(a) is posted or ordered to patrol or has adopted the position of sentry at a post or has undertaken the patrol ; or

(b) is a member of a guard or other party mounted or ordered to patrol, for the purposes of protecting any persons, premises or place.

(6) The foregoing provisions of this section shall apply in relation to persons posted or ordered to patrol or who have adopted the position of sentries at a post or have undertaken the patrol, and to members of a party mounted or ordered to patrol, for the purpose of preventing or

controlling access to or egress from any premises or place, or of regulating traffic by air, road, or rail, or on any inland navigation, as they apply to persons on guard duty.

Looting.

38. Any person who—

(a) steals from, or with intent to steal searches, the person of anyone killed or wounded in the course of warlike operations ; or

(b) steals any property which has been left exposed or unprotected in consequence of warlike operations ; or

(c) takes otherwise than for the service of the public any vehicle, equipment or stores abandoned by the enemy,

shall be guilty of looting and liable, on conviction by court martial, to imprisonment or any less punishment provided by this Act.

#### *Mutiny and Insubordination*

Mutiny.

39.—(1) Any person who—

(a) takes part in a mutiny involving the use of violence or the threat of the use of violence, or having as its object or one of its objects the refusal or avoidance of any duty or service against, or in connection with operations against the enemy or the impeding of the performance of any such duty or service ; or

(b) incites any person subject to service law to take part in such a mutiny, whether actual or intended,

shall, on conviction by court martial, be liable to suffer death or any other punishment provided by this Act.

(2) Any person who, in a case not falling within subsection (1) of this section, takes part in a mutiny, or incites any person subject to service law to take part in a mutiny, whether actual or intended, shall, on conviction by court martial, be liable to imprisonment or any less punishment provided by this Act.

Failure to  
suppress  
mutiny.

40.—(1) Any person who, knowing that a mutiny is taking place or is intended—

(a) fails to use his utmost endeavours to suppress or prevent it ; or

(b) fails to report without delay that the mutiny is taking place or is intended,

shall on conviction by court martial—

(i) if his offence was committed with intent to assist the enemy, be liable to suffer death or any other punishment provided by this Act ; or

(ii) in any other case, be liable to imprisonment or any less punishment provided by this Act.

Insub-  
ordinate  
behaviour.

41.—(1) Any person who—

(a) strikes or otherwise uses violence to, or offers violence to his superior officer ; or

(b) uses threatening or insubordinate language to his superior officer, shall, on conviction by court martial, be liable to imprisonment or any less punishment provided by this Act :

Provided that he shall not be liable to be imprisoned for more than two years if the offence was not committed on active service or did not involve the striking or other use of violence, or offering of violence, to a superior officer exercising authority as such.

(2) In this section, the expression "superior officer", in relation to any person, means an officer, warrant officer or non-commissioned officer subject to service law of superior rank, and includes an officer, warrant officer or non-commissioned officer so subject of equal rank but greater seniority while exercising authority as the said person's superior.

42. Any person who—

(1) in such manner as to show a wilful defiance of authority, disobeys any lawful command given or sent to him personally shall, on conviction by court martial, be liable to imprisonment or any less punishment provided by this Act ; and

(2) whether wilfully or through neglect, disobeys any lawful command shall, on conviction by court martial, be liable to imprisonment or any less punishment provided by this Act :

Provided that if the offence was not committed on active service he shall not be liable to be imprisoned for more than two years.

43. Any person who—

(a) obstructs ; or

(b) when called on, refuses to assist,

any other person known to him to be a provost officer, or to be a person (whether subject to air force law under this Act or not) lawfully exercising authority under or on behalf of a provost officer, shall, on conviction by court martial, be liable to imprisonment for a term not exceeding two years or any less punishment provided by this Act.

44.—(1) Any person who contravenes or fails to comply with any provision of orders to which this section applies, being a provision known to him, or which he might reasonably be expected to know, shall, on conviction by court martial, be liable to imprisonment for a term not exceeding two years or any less punishment provided by this Act.

(2) This section applies to standing orders or other routine orders of a continuing nature made for any formation, unit or body of air force personnel, or for any command or other area, garrison or place, or for any ship, train or aircraft.

*Desertion and Absence without Leave*

45.—(1) any person who—

(a) deserts ; or

(b) persuades or procures any other person subject to service law to desert,

shall, on conviction by court martial, be liable to imprisonment or any less punishment provided by this Act ; but a person shall not be liable to be imprisoned for more than two years unless—

(i) if the offence was against paragraph (a) of this subsection, he was on active service or under orders for active service at the time when it was committed ; or

Disobedience of particular orders.

Obstruction of provost officers.

Disobedience of standing orders.

Desertion.

(ii) if the offence was against paragraph (b) of this subsection, the person in relation to whom it was committed was on active service or under orders for active service at that time.

(2) In addition to or in lieu of any punishment authorised by subsection (1) of this section, the court martial by whom an airman is convicted of desertion may direct that the whole or part of his service previous to the period as respects which he is convicted of having been a deserter shall, if he is not a reservist called out on permanent service, be forfeited.

Absence  
without  
leave.

46. Any person who—

(a) absents himself without leave ; or

(b) persuades or procures any other person subject to service law to absent himself without leave,

shall, on conviction by court martial, be liable to imprisonment for a term not exceeding two years or any less punishment provided by this Act.

Assisting  
and con-  
cealing  
desertion and  
absence  
without  
leave.

47. Any person who—

(a) knowingly assists any other person subject to service law to desert or absent himself without leave ; or

(b) knowing that any other person subject to service law has deserted or absented himself without leave, or is attempting to desert or absent himself without leave, fails to report that fact without delay, or fails to take any steps in his power to cause that other person to be apprehended,

shall, on conviction by court martial, be liable to imprisonment for a term not exceeding two years or any less punishment provided by this Act.

Failure to  
perform air  
force duties.

48. Any person who without reasonable excuse fails to attend for any parade or other air force duty of any description or leaves any such parade or duty as aforesaid before he is permitted to do so shall, on conviction by court martial, be liable to imprisonment for a term not exceeding two years or any less punishment provided by this Act.

#### *Malingering and Drunkenness*

Malingering.

49. Any person who—

(a) falsely pretends to be suffering from sickness or disability ; or

(b) injures himself with intent thereby to render himself unfit or temporarily unfit for service, or causes himself to be injured by any other person with that intent ; or

(c) injures any other person subject to service law, at the instance of that other person, with intent thereby to render that other person unfit or temporarily unfit for service ; or

(d) with intent to render or keep himself unfit or temporarily unfit for service does or fails to do anything (whether at the time of the act or omission he is in hospital or not) whereby he produces, prolongs or aggravates, any sickness or disability,

shall be guilty of malingering and shall, on conviction by court martial, be liable to imprisonment for a term not exceeding two years or any less punishment provided by this Act.

50.—(1) Any person who is guilty of drunkenness, whether on duty or not, shall, on conviction by court martial, be liable to imprisonment for a term not exceeding two years or any less punishment provided by this Act :

Drunkenness.

Provided that where the offence is committed by an airman not on active service or on duty, the sentence imposed shall not exceed imprisonment for a period of six months.

(2) For the purpose of this section a person is guilty of drunkenness if owing to the influence of alcohol or any drug, whether alone or in combination with any other circumstances, he is unfit to be entrusted with his duty or with any duty which he may be called upon to perform, or behaves in a disorderly manner or in any manner likely to bring discredit to the armed forces of Nigeria.

### *Offences relating to Property*

51. Any person who—

(a) steals or fraudulently misapplies any public or service property, or is concerned in or connives at the stealing or fraudulent misapplication of any public or service property ; or

(b) receives or retains any public or service property knowing or having reason to believe it to have been stolen or to have been fraudulently misapplied ; or

(c) wilfully damages, or is concerned in the wilful damage of, any public or service property ; or

(d) by wilful neglect causes damage to any public or service property, shall, on conviction by court martial, be liable to imprisonment or any less punishment provided by this Act.

Offences in relation to public and service property.

52. Any person who—

(a) steals or fraudulently misapplies any property belonging to a person subject to service law, or is concerned in or connives at the stealing or fraudulent misapplication of any such property ; or

(b) receives or retains any such property knowing or having reason to believe the same to have been stolen or to have been fraudulently misapplied ; or

(c) wilfully damages, or is concerned in the wilful damage of, any property belonging to a person subject to service law, shall, on conviction by court martial, be liable to imprisonment for a term not exceeding two years or any less punishment provided by this Act.

Offences in relation to property of members of forces.

53. Any person who—

(a) loses any public or service property of which he has the charge or which has been entrusted to his care or which forms part of property of which he has the charge or which has been entrusted to his care ; or

(b) by negligence damages any public or service property of which he has the charge or which has been entrusted to his care or which forms part of the property of which he has the charge or which has been entrusted to his care ; or

Miscellaneous offences relating to property.

(c) by negligence causes damage to any public or service property ; or  
 (d) fails to take proper care of any animal or bird used in the public service which is in his charge ; or

(e) makes away (by pawning or in any other way) with any air force decoration granted to him or any clothing, arms, ammunition or other equipment issued to him for his use for air force purposes, shall, on conviction by court martial, be liable to imprisonment for a term not exceeding two years or any less punishment under this Act :

Provided that it shall be a defence for any person charged under paragraph (a) of this section with losing any property that he took reasonable steps for the care and preservation thereof.

#### *Flying, etc., Offences*

Dangerous flying, etc.

54. Any person who is guilty of any act or neglect in flying or in the use of any aircraft, or in relation to any aircraft or aircraft material, which causes or is likely to cause loss of life or bodily injury to any person shall, on conviction by court martial, be liable to imprisonment or any less punishment provided by this Act :

Provided that if the offender has not acted wilfully or with wilful neglect he shall not be liable to be imprisoned for more than two years.

Inaccurate certification of aircraft, etc.

55. Any person who signs any certificate in relation to an aircraft or to aircraft material without ensuring the accuracy of the certificate shall, on conviction by court martial, be liable to imprisonment for a term not exceeding two years or any less punishment provided by this Act.

Low flying.

56. Any officer, airman or other person in the air force who being the pilot of a Nigerian service aircraft, flies it at a height less than the height from time to time prescribed by regulations made by the air council under this Act except while taking-off or alighting, or in such other situation as may be so prescribed shall, on conviction by court martial, be liable to imprisonment for a term not exceeding two years or any less punishment provided by this Act.

Annoyance by flying.

57. Any officer, airman or other person in the air force who, being the pilot of a Nigerian service aircraft, flies it so as to cause, or to be likely to cause, unnecessary annoyance to any person shall, on conviction by court martial, be liable to imprisonment for a term not exceeding two years or any less punishment provided by this Act.

#### *Offences relating to and by Persons in Custody*

Irregular arrest and confinement.

58.—(1) Any person who, when an officer or airman or other person subject to air force law is under arrest—

(a) unnecessarily delays the investigation of allegations against that officer, airman or other person or, as the case may be, his trial by court martial ; or

(b) fails to release, or effect the release of, that officer, airman or other person when it is his duty to do so, shall be guilty of an offence against this section.

(2) Where any person (elsewhere in this section referred to as "the prisoner") is committed to the custody of any provost officer or other officer, or any warrant officer or non-commissioned officer, and the person so committing the prisoner fails without reasonable cause to deliver—

(a) at the time of the committal, or

(b) if it is not practicable so to do at the time of the committal, then within twenty-four hours thereafter, to the person to whose custody the prisoner was committed, a report in writing signed by himself of the offence which the prisoner is alleged to have committed, he shall be guilty of an offence against this section.

(3) Where a prisoner is committed to the charge of any person who is in command of a guard, and the guard commander fails without reasonable excuse to give to the officer to whom it is his duty to report, as soon as may be after he is relieved from his guard and any further duty or, if he is not sooner relieved, within twenty-four hours after the committal,—

(a) a written statement containing as far as known to him, the name of the prisoner with particulars of the alleged offence, and the name and rank or other description of the officer or other person by whom the prisoner is alleged to have committed the offence, and

(b) (if he has received it) the report required by subsection (2) of this section, he shall be guilty of an offence against this section.

(4) Any person guilty of an offence against this section shall, on conviction by court martial, be liable to imprisonment for a term not exceeding two years or any less punishment provided by this Act.

59.—(1) Any person who wilfully allows to escape any person who is committed to his charge, or whom it is his duty to guard, shall, on conviction by court martial, be liable to imprisonment or any less punishment provided by this Act.

Permitting escape, and unlawful release, of prisoners.

(2) Any person who—

(a) without proper authority releases any person who is committed to his charge ; or

(b) without reasonable excuse allows to escape any person who is committed to his charge, or whom it is his duty to guard, shall, on conviction by court martial, be liable to imprisonment for a term not exceeding two years or any less punishment provided by this Act.

60.—(1) Any person who, being concerned in any quarrel or disorder, refuses to obey any officer who orders him into arrest, or strikes or otherwise uses violence to, or offers violence to, any such officer, shall be guilty of an offence against this section whether or not the officer is his superior officer.

Resistance to arrest.

(2) Any person who strikes or otherwise uses violence to, or offers violence to any person whose duty it is to apprehend him or in whose custody he is shall be guilty of an offence against this section.

(3) Any person guilty of an offence against this section shall, on conviction by court martial, be liable to imprisonment for a term not exceeding two years or any less punishment provided by this Act.

Escape from  
confinement.

61. Any person who escapes from arrest, prison or other lawful custody (whether air force custody or not) shall, on conviction by court martial, be liable to imprisonment for a term not exceeding two years or any less punishment provided by this Act.

*Offences in relation to Courts Martial and Civil Authorities*

Offences in  
relation to  
courts mar-  
tial.

62.—(1) Any person who—

(a) having been duly summoned or ordered to attend as a witness before a court martial, fails to comply with the summons or order ; or

(b) refuses to swear an oath or make an affirmation when duly required by a court martial to do so ; or

(c) refuses to produce any document in his custody or under his control which a court martial has lawfully required him to produce ; or

(d) when a witness, refuses to answer any question which a court martial has lawfully required him to answer ; or

(e) wilfully insults any person, being a member of a court martial or a witness or any other person whose duty it is to attend on or before the court, while that person is acting as a member thereof or is so attending, or wilfully insults any such person as aforesaid while that person is going to or returning from the proceedings of the court ; or

(f) wilfully interrupts the proceedings of a court martial, or otherwise misbehaves before the court,

shall, on conviction by a court martial, other than the court in relation to which the offence was committed, be liable to imprisonment for a term not exceeding two years or any less punishment provided by this Act.

(2) Notwithstanding anything in subsection (1) of this section where an offence against paragraph (e) or paragraph (f) of that subsection is committed in relation to any court martial held in pursuance of this Act that court, if of opinion that it is expedient that the offender should be dealt with summarily by the court instead of being brought to trial before another court martial, may by order under the hand of the president of the court order the offender to be imprisoned for a period not exceeding twenty-one days.

(3) References in paragraphs (a) to (f) of subsection (1) of this section to a court martial shall include references to a court martial held in pursuance of service law.

False  
evidence.

63.—(1) Any person who, having been duly sworn as a witness or as an interpreter in proceedings before a court martial or before any board or person having power to administer an oath under service law, makes a statement material in those proceedings knowing it to be false or recklessly without belief in its truth shall, on conviction by court martial, be liable to imprisonment for a term not exceeding two years or any less punishment provided by this Act.

(2) A person shall not be liable to be convicted of an offence against this section upon the evidence, sworn or unsworn, of one witness alone as to the truth or untruth of any statement alleged to be false.

64. Any person who at any place either within or outside Nigeria prevents or obstructs—

Obstruction of police officer arresting officer or airman.

(a) the execution by a police officer of a warrant for the arrest of a person subject to service law who has committed or is suspected of having committed an offence punishable on conviction by a civil court ; or

(b) the arrest of a person subject to service law by a police officer acting in the exercise of his powers of arrest without warrant,

shall, on conviction by court martial, be liable to imprisonment for a term not exceeding two years or any less punishment provided by this Act.

#### *Miscellaneous Offences*

65.—(1) Any person who without authority discloses, by any means whatsoever, information which is or purports to be information useful to an enemy shall, on conviction by court martial, be liable to imprisonment for a term not exceeding two years or any less punishment provided by this Act.

Injurious disclosure.

(2) In this section the expression “information useful to an enemy” means information as to any matter such that information as to it would or might be directly or indirectly useful to an enemy, and in particular (but without prejudice to the generality of the foregoing provisions of this subsection) information as to any matter falling within the following paragraphs, being a matter such that information as to it would or might be useful as aforesaid, that is to say—

(a) the number, description, armament, equipment, disposition, movement or condition of any of the armed forces of Nigeria or of any forces co-operating therewith, or any of Nigerian ships or aircraft or of the ships or aircraft of any such co-operating force ; or

(b) any operations or projected operations of any of such forces, ships or aircraft as aforesaid ; or

(c) any code, cipher, call sign, password or countersign ; or

(d) any measures for the defence or fortification of any place on behalf of Nigeria ; or

(e) the number, description or location of any prisoners of war ; or

(f) munitions of war.

66. Any person who, when before a recruiting officer for the purpose of being attested in pursuance of Part III of this Act has knowingly made a false answer to any question contained in the attestation paper and put to him by or by the direction of the recruiting officer shall, on conviction by court martial, if he is subject to air force law, be liable to imprisonment for a term not exceeding three months or to any less punishment provided by this Act.

Making of false statements on enlistment

67. Any person who—

(a) makes, signs or makes an entry in any service report, return, pay list or certificate or other service document, being a document or entry which is to his knowledge false in a material particular ; or

Making false documents.

(b) alters any service report, return, pay list or certificate or other service document, or alters any entry in such a document, so that the document or entry is to his knowledge false in a material particular, or suppresses, defaces or makes away with any such document or entry which it is his duty to preserve or produce; or

(c) with intent to defraud, fails to make an entry in any such document; or

(d) aids, abets, commands, counsels, procures or connives at the commission by another person subject to service law of an offence against this section or the corresponding section of the appropriate service law, as the case may be (whether or not he knows the nature of the document in relation to which that offence will be committed), shall, on conviction by court martial, be liable to imprisonment for a term not exceeding two years or any less punishment provided by this Act.

Scandalous conduct of officer.

68. Every officer who behaves in a scandalous manner, unbecoming the character of an officer and a gentleman, shall, on conviction by court martial, be cashiered.

Ill-treatment of officers or airmen of inferior rank.

69. If—

(a) any officer subject to air force law strikes or otherwise ill-treats any other officer subject to service law of inferior rank or less seniority or any airman subject to service law, or

(b) any warrant officer or non-commissioned officer subject to air force law strikes or otherwise ill-treats any person subject to service law, being a warrant officer or non-commissioned officer of inferior rank or less seniority or an airman,

any such officer shall, on conviction by court martial, be liable to imprisonment for a term not exceeding two years or any less punishment provided by this Act.

Disgraceful conduct.

70. Any person who is guilty of disgraceful conduct of a cruel, indecent or unnatural kind, shall, on conviction by court martial, be liable to imprisonment for a term not exceeding two years or any less punishment provided by this Act.

False accusation.

71. Any person who—

(a) makes an accusation against any officer or airman subject to service law, knowing it to be false or recklessly without belief in its truth; or

(b) in making a complaint where he thinks himself wronged, makes a statement affecting the character of an officer or airman subject to service law, knowing it to be false or recklessly without belief in its truth or wilfully suppresses any material fact, shall, on conviction by court martial, be liable to imprisonment for a term not exceeding two years or any less punishment provided by this Act.

Attempts to commit air force offence.

72. Any person who attempts to commit an offence against any of the foregoing provisions of this Part of this Act shall, on conviction by court martial, be liable to the like punishment as for that offence:

Provided that if the offence is one punishable by death he shall not be liable to any greater punishment than imprisonment.

73. Any person who is guilty of any conduct or neglect to the prejudice of good order and air force discipline shall, on conviction by court martial, be liable to imprisonment for a term not exceeding two years or any less punishment provided by this Act. Conduct to prejudice of air force discipline.

#### *Civil Offences*

74.—(1) Any officer or airman who commits a civil offence within the meaning of this Act in Nigeria or elsewhere, shall be guilty of an offence against this section. Civil offences.

(2) For the purposes of the foregoing subsection, "civil offence" means any act or omission punishable as an offence under the penal provisions of any law enacted in or applicable to Nigeria, and "the corresponding civil offence" means the civil offence the commission of which constitutes the offence against this section.

(3) Subject to the next succeeding subsection, a person convicted by court martial of an offence against this section shall—

(a) if the corresponding civil offence is treason or murder be liable to suffer death, and

(b) in any other case, be liable to suffer the punishment which a civil court might award for the corresponding civil offence, if committed anywhere in Nigeria being a punishment provided by this Act or such lesser punishment which a civil court could so award, as is so provided.

(4) Where a court other than a court martial may not award a term of imprisonment for a civil offence, a person convicted of a civil offence shall be liable to suffer such punishment, less than cashiering in the case of an officer, or discharge with ignominy in the case of an airman, as is prescribed for the civil offence.

(5) Nothing in this section shall be construed to authorise the charging of a person with an offence against this section committed in Nigeria if the corresponding civil offence is treason, murder, manslaughter, treasonable felony or rape; and for the purposes of this subsection where the corresponding civil offence is murder or manslaughter an offence against this section shall be deemed to have been committed at the place of the commission of the act or occurrence of the negligence which caused the death, irrespective of the place of the death.

#### *Punishments*

75.—(1) The punishments which may be awarded to an officer by sentence of a court martial under this Act are, subject to the limitations hereinafter provided on the powers of certain courts martial, those set out in the following scale; and in relation to an officer references in this Act to punishments provided by this Act are references to those punishments. Punishment of officers.

(2) The said scale is—

(a) death;

(b) imprisonment;

(c) cashiering;

(d) dismissal from the armed forces of Nigeria;

(e) a fine of a sum not exceeding the equivalent of ninety days' pay

(f) severe reprimand or reprimand ;

(g) where the offence has occasioned any expense, loss or damage, stoppages.

(3) For the purposes of this Part of this Act, a punishment specified in any paragraph of the said scale shall be treated as less than the punishments specified in the preceding paragraphs, and greater than those specified in the following paragraphs, of the scale.

(4) Save as expressly provided in this Act, not more than one punishment shall be awarded by a court martial for one offence.

(5) Stoppages may be awarded by a court martial either in addition to or without any other punishment.

(6) A severe reprimand or reprimand may be awarded by a court martial in addition to a fine.

(7) Where an officer is sentenced by a court martial to imprisonment, he shall also be sentenced to be cashiered :

Provided that if the court martial fails to sentence him to be cashiered, the sentence of imprisonment shall not be invalid but shall be deemed to include a sentence of cashiering.

Punishment  
of warrant  
officers, non-  
commis-  
sioned  
officers and  
airmen.

76.—(1) The punishments which may be awarded to a warrant officer, non-commissioned officer or airman by sentence of a court martial under this Act are, subject to the limitations hereinafter provided on the powers of certain courts martial, those set out in the following scale ; and in relation to a warrant officer, non-commissioned officer or airman references in this Act to punishments provided by this Act are references to those punishments.

(2) The said scale is—

(a) death ;

(b) imprisonment ;

(c) discharge with ignominy from the armed forces of Nigeria ;

(d) in the case of a warrant officer, dismissal from the armed forces of Nigeria ;

(e) in the case of a warrant officer or non-commissioned officer, reduction to the ranks or any less reduction in rank ;

(f) a fine of a sum not exceeding the equivalent of ninety days' pay ;

(g) in the case of a warrant officer or non-commissioned officer, severe reprimand or reprimand ;

(h) where the offence is desertion, forfeiture of service ;

(i) where the offence has occasioned any expense, loss or damage, stoppages.

(3) For the purposes of this Part of this Act, a punishment specified in any paragraph of the said scale shall be treated as less than the punishments specified in the preceding paragraphs, and greater than those specified in the following paragraphs, of the scale.

(4) Save as expressly provided in this Act, not more than one punishment shall be awarded by a court martial for one offence.

(5) A warrant officer, non-commissioned officer or airman sentenced by a court martial to imprisonment may in addition thereto be sentenced to be discharged with ignominy from the service of the armed forces of Nigeria.

(6) Where a warrant officer or non-commissioned officer is sentenced by a court martial to imprisonment he shall also be sentenced to be reduced to the ranks :

Provided that if the court martial fails to sentence him to be so reduced, the sentence shall not be invalid but shall be deemed to include a sentence of reduction to the ranks.

(7) In the case of a warrant officer or non-commissioned officer, a severe reprimand or reprimand may be awarded by a court martial in addition to a fine.

(8) Stoppages may be awarded by a court martial either in addition to or without any other punishment.

77.—(1) In relation to an offence committed by an airman on active service, the scale set out in subsection (2) of section seventy-six of this Act shall have effect as if after paragraph (d) thereof there were inserted the following paragraph—

Field  
punishment.

“(dd) field punishment for a period not exceeding ninety days ;” and subsection (6) of the said section seventy-six shall apply to field punishment as it applies to imprisonment.

(2) Field punishment shall consist of such duties or drills, in addition to those which the offender might be required to perform if he were not undergoing punishment, and such loss of privileges, as may be provided, and may include confinement in such place and manner as may be so provided and such personal restraint as may be necessary to prevent the escape of the offender and as may be so provided. In this subsection “as may be provided” means as may be provided by rules made under this Part of this Act.

#### *Arrest*

78.—(1) Any person found committing an offence against any provision of this Act, or alleged to have committed or reasonably suspected of having committed any such offence, may be arrested in accordance with the following provisions of this section.

Power to  
arrest  
offenders.

(2) An officer may be arrested by an officer subject to service law of superior rank, or, if engaged in a quarrel or disorder, by such an officer of any rank.

(3) An airman may be arrested by an officer, warrant officer or non-commissioned officer subject to service law, but no airman shall be arrested under this subsection except by a person of superior rank.

(4) A provost officer, or any officer, warrant officer, non-commissioned officer, airman, soldier or rating subject to service law lawfully exercising authority under a provost officer or on his behalf, may arrest any officer or airman ; but no officer shall be arrested under this subsection except on the order of another officer.

(5) The power of arrest given to any person by this section may be exercised either personally or by ordering into arrest the person to be arrested or by giving orders for that person's arrest.

Provisions for avoiding delay after arrest.

79.—(1) The allegations against any person who is under arrest shall be duly investigated without unnecessary delay, and as soon as may be either proceedings shall be taken for punishing his offence or he shall be released from arrest.

(2) If any person taken into air force custody, remains under arrest for a longer period than eight days without a court martial for his trial being assembled, a special report on the necessity for further delay shall be made by his commanding officer as may be prescribed and a similar report shall be made not later than every eight days thereafter or (whichever event first happens) until a court martial is assembled or the offence is dealt with summarily or the person is released from arrest :

Provided that in the case of a person on active service compliance with this subsection shall be excused in so far as it is not reasonably practicable having regard to the exigencies of air force operations.

(3) For the purposes of subsection (1) of section fifty-eight of this Act, (which relates to irregular arrest and confinement) the question whether there has been unnecessary delay in the investigation of allegations against a person under arrest, shall be determined without regard to the provisions of subsection (2) of this section.

#### *Investigation of and Summary Dealing with Charges*

Investigation of charges by commanding officers.

80. Before an allegation against a person that he has committed an offence against any provision of this Part of this Act is further proceeded with, the allegation shall be reported, in the form of a charge, to the commanding officer of the person so charged and the commanding officer shall investigate the charge in the prescribed manner.

Charges to be dealt with summarily or by court martial.

81.—(1) After investigation, a charge against an officer below the rank of wing commander or against a warrant officer may, if an authority has power under the provisions of this Part of this Act to deal with it summarily, be so dealt with by that authority (in this Act referred to as "the appropriate superior authority") in accordance with those provisions.

(2) After investigation, a charge against a non-commissioned officer or airman may be dealt with summarily by his commanding officer, subject to and in accordance with the following provisions of this Part of this Act.

(3) Any charge not dealt with summarily as aforesaid shall after investigation be remanded for trial by court martial.

(4) Notwithstanding anything in the foregoing provisions of this section, where the commanding officer has investigated a charge against an officer or warrant officer he may dismiss the charge if he is of opinion that it ought not to be further proceeded with.

(5) References in this Act to dealing summarily with a charge are references to the taking by the appropriate superior authority or the commanding officer of the person charged, as the case may require, of the following action, that is to say, determining whether the person charged is guilty, dismissing the charge or recording a finding of guilty accordingly, and awarding punishment.

82.—(1) The following provisions of this section shall have effect where the commanding officer has investigated a charge against a non-commissioned officer or airman.

Further proceedings on charges against non-commissioned officers and airmen.

(2) If the charge is one which might be dealt with summarily but the commanding officer is of opinion that it should not be so dealt with, he shall arrange for the charge to be tried by court martial.

(3) If the commanding officer is satisfied that the charge is one which might be dealt with summarily he shall deal with the charge accordingly; and if he records a finding of guilty he may award one or more of the following punishments, that is to say—

(a) if the accused is a non-commissioned officer—

- (i) reduction to the ranks in the case of a leading aircraftman;
- (ii) a fine of a sum not exceeding the equivalent of twenty-eight days' pay;
- (iii) severe reprimand or reprimand;
- (iv) admonition;
- (v) where the offence has occasioned any expense, loss or damage, stoppages;

(b) if the accused is an airman other than a non-commissioned officer or a boy—

- (i) imprisonment for a period not exceeding twenty-eight days or, if the accused is on active service, field punishment for a period not exceeding twenty-eight days;
- (ii) a fine of a sum not exceeding the equivalent of twenty-eight days' pay;
- (iii) confinement to barracks for a period beginning with the day of the sentence and not exceeding twenty-eight days;
- (iv) extra guards or piquets not exceeding seven in number;
- (v) admonition;
- (vi) where the offence has occasioned any expense, loss or damage, stoppages;

(c) if the accused is a boy—

- (i) a fine of a sum not exceeding the equivalent of twenty-eight days' pay;
- (ii) confinement to barracks for a period beginning with the day of the sentence and not exceeding seven days;
- (iii) extra guards or piquets not exceeding seven in number;
- (iv) admonition;
- (v) where the offence has occasioned any expense, loss or damage, stoppages.

(4) Where a commanding officer, in dealing summarily with a charge, considers it appropriate that a punishment of reduction in rank or to the ranks, in the case of a non-commissioned officer (other than a leading aircraftman), or of dismissal from the service, in the

case of an airman or a boy, should be awarded (either alone or in addition to any other punishment) he shall refer the case in the prescribed manner to the commander; and the commander shall, as he thinks fit, either—

(a) award one or more of—

(i) the punishment of reduction in rank or to the ranks or dismissal, as the case may be; and

(ii) the punishments which the commanding officer could have awarded; or

(b) quash the finding of guilty.

(5) Where the commanding officer has arranged for the charge to be tried by court martial, any higher authority to whom the charge is referred may refer the charge back to the commanding officer to be dealt with summarily; and on any such reference subsection (3) of this section shall have effect as if the commanding officer were satisfied that the charge should be dealt with summarily.

Further proceedings on charges against officers and warrant officers.

83.—(1) Where the commanding officer has investigated a charge against an officer or warrant officer he shall, unless he dismisses the charge, refer the case to higher authority and if the charge is so referred, the higher authority shall prescribe the procedure to be followed by court martial or otherwise, and if he thinks it a case for court martial, he shall refer the case to the appropriate superior authority as a case for court martial. That authority shall investigate the charge in the prescribed manner and determine whether the accused is guilty of the charge, and accordingly may record a finding of guilty, or dismiss the charge, or refer the case back for trial by court martial. If the case is referred back for trial by court martial, the appropriate authority shall do all things necessary to convene a court.

(2) If the higher authority or the appropriate superior authority as the case may be, records a finding of guilty, that authority may award one or more of the following punishments, that is to say—

(a) a fine of a sum not exceeding the equivalent of twenty-eight days' pay;

(b) severe reprimand or reprimand;

(c) where the offence has occasioned any expense, loss or damage stoppages of pay.

(3) Notwithstanding anything in subsection (2) of this section, where the higher authority or an appropriate superior authority, as the case may be, is satisfied as to the guilt of the person charged and would, if the case were dealt with summarily award a fine or stoppages of pay, that authority shall not record a finding until the person charged elects whether or not to be tried by court martial; and if the accused elects to be so tried, that authority shall do all things necessary to constitute a court martial and shall not record his finding.

84.—(1) Notwithstanding anything in sections eighty-two and eighty-three of this Act, where a charge—

(a) has been referred to higher authority with a view to its being tried by court martial; or

Dismissal of charges referred to higher authority.

(b) has been submitted to higher authority for determination how it is to be proceeded with, that authority may, subject to the provisions of this section, refer the charge back to the commanding officer of the accused with a direction that it be dismissed, and in any such case the commanding officer shall dismiss the charge.

(2) The reference back of a charge in pursuance of this section shall be without prejudice to the preferring of another charge if the higher authority has so directed or the commanding officer thinks fit.

85.—(1) The following persons may act as appropriate superior authority in relation to a person charged with an offence, that is to say, the commander and any officer of the rank of air commodore or above or officer of corresponding rank under whose command the person is for the time being.

Officers who are to act as appropriate superior authorities and to whom commanding officers may delegate powers.

(2) Rules may be made by the air council with the approval of the Minister for the purpose of this section and such rules may confer on commanding officers power to delegate their functions, in such cases and to such extent as may be specified in the rules, to officers of a class so specified.

#### *Courts Martial*

##### *(a) General Provisions*

86.—(1) A court martial shall subject to the provisions of this section have the power to try any person subject to air force law under this Act for any offence which, under this Act, is triable by court martial and to award for any such offence any punishment authorised by this Act for that offence.

Powers of courts martial.

(2) A court martial for the trial of an officer or a warrant officer shall consist of at least five officers.

(3) A court martial consisting of less than five officers shall not award any punishment higher in the scale of punishment than imprisonment for two years.

(4) A court martial consisting of less than five officers shall not try any offence for which the maximum or only punishment is death.

87. A court martial may be convened by the commander or by any air officer, air commodore or group captain or officer of corresponding rank commanding a body of air force personnel or any officer for the time being acting in place of the commander or such air officer, air commodore or group captain or officer of corresponding rank.

Officers having power to convene courts martial.

88.—(1) Subject to the provisions of section eighty-six of this Act a court martial shall consist of the president and not less than two other officers.

Constitution of courts martial.

(2) An officer shall not be appointed to be a member of a court martial unless he is subject to service law and has been an officer in any of the armed forces of Nigeria for a period of not less than two years or for periods amounting in the aggregate to not less than two years.

(3) The president of a court martial shall be appointed by order of the convening officer and shall not be under the rank of squadron leader or corresponding rank unless in the opinion of the convening officer a squadron leader or officer of corresponding rank having suitable qualifications is not, with due regard to the public service, available; and in any event the president of a court martial shall not be under the rank of flight lieutenant or corresponding rank.

(4) The members of a court martial, other than the president, shall be appointed by order of the convening officer or in such other manner as may be prescribed.

Supplementary provision as to constitution of courts martial.

89.—(1) The officer convening a court martial shall not be a member of that court martial; but if in the opinion of the convening officer it is not practicable to appoint another officer as president, he may himself be president of the court martial.

(2) An officer who, at anytime between the date on which the accused was charged with the offence and the date of the trial, has been the commanding officer of the accused, and any other officer who has investigated the charge against the accused, or who under service law has held, or has acted as one of the persons holding, an inquiry into matters relating to the subject matter of the charge against the accused, shall not sit as a member of a court martial or act as judge advocate at such a court martial.

(3) When the officer convening a court martial appoints a flight lieutenant or officer of corresponding rank to be president, being of opinion that a squadron leader or officer of corresponding rank having suitable qualifications is not with due regard to the public service available, the order convening the court martial shall contain a statement of such opinion; and the statement shall be accepted as conclusive for the purposes of the court martial.

Place for sitting of courts martial and adjournment to other places.

90.—(1) Subject to the provisions of this section, a court martial shall sit at such place as may be specified in the order convening the court; and the convening officer may convene it to sit at a place outside the limits of his command.

(2) A court martial sitting at any place shall, if the convening officer so directs, sit at some other place; and without any such direction if it appears to the court to be in the interests of justice to sit at some other place, may adjourn for the purpose of sitting at that other place.

(b) *Provisions relating to Trial*

Challenges by accused.

91.—(1) An accused about to be tried by a court martial shall be entitled to object, on any reasonable ground, to any member of the court, whether appointed originally or in lieu of another officer.

(2) For the purpose of enabling the accused to avail himself of the right conferred by subsection (1) of this section the names of the members of the court shall be read over in the presence of the accused before they are sworn, and he shall be asked whether he objects to any of those officers.

(3) Every objection made by an accused to any officer shall be considered by the other officers appointed members of the court.

(4) If objection is made to the president and not less than one-third of the other members of the court allow it, the court shall adjourn and the convening officer shall appoint another president.

(5) If objection is made to a member of the court other than the president and not less than one-half of the members entitled to vote allow it, the member objected to shall retire and the vacancy may, and if otherwise the number of members would be reduced below the legal minimum shall, be filled in the prescribed manner by another officer.

92.—(1) An oath shall be administered to every member of a court martial and to any person in attendance on a court martial as judge advocate, officer under instruction, shorthand writer or interpreter.

Administration of oaths.

(2) Every witness before a court martial shall be examined on oath :

Provided that where any child called as a witness does not in the opinion of the court understand the nature of an oath, his evidence may be received, though not given upon oath, if in the opinion of the court he is possessed of sufficient intelligence to justify the reception of the evidence and understands the duty of speaking the truth, so however that, where the evidence is given on behalf of the prosecution, the accused shall not be liable to be convicted upon such evidence alone unless it is corroborated by some other material evidence in support thereof implicating the accused.

(3) An oath required to be administered under this section shall be in the form prescribed by the Oaths Act, 1963, or if no form is so prescribed, as near thereto as may be in any particular case, and shall be administered accordingly.

1963, No. 23.

93.—(1) Subject to the provisions of this section, a court martial shall sit in open court and in the presence of the accused.

Courts martial to sit in open court.

(2) Nothing in subsection (1) of this section shall affect the power of a court martial to sit in camera on the ground that it is necessary or expedient in the interests of the administration of justice to do so ; and without prejudice to that power a court martial may order that, subject to any exceptions the court may specify, the public shall be excluded from all or any part of the proceedings of the court if it appears to the court that any evidence to be given or statement to be made in the course of the proceedings or that part, as the case may be, might otherwise lead to the disclosure of any information which would or might be directly or indirectly useful to an enemy.

(3) A court martial shall sit in closed court while deliberating on their finding or sentence on any charge.

(4) A court martial may sit in closed court on any other deliberation amongst the members.

(5) Where a court martial sits in closed court no person shall be present except the members of the court and such other persons as may be prescribed.

94.—(1) Where, whether before or after the commencement of the trial, it appears to the convening officer necessary or expedient in the interests of the administration of justice that a court martial should be dissolved, the convening officer may by order dissolve the court martial.

Dissolution of courts martial.

(2) Without prejudice to the generality of the foregoing subsection, if after the commencement of the trial—

(a) a court martial is, by reason of the death of one of the members or for any other reason, reduced below the legal minimum, it shall be dissolved;

(b) it is represented to the convening officer that owing to the sickness or other incapacity of the accused it is impracticable having regard to all the circumstances to continue the trial within a reasonable time, the convening officer may dissolve the court.

(3) If after the commencement of the trial the president dies or is otherwise unable to attend and the court is not reduced below the legal minimum, then if the senior member of the court is of the rank of flight lieutenant or corresponding rank or is of higher rank, the convening officer may appoint him president and the trial shall proceed accordingly; but if the senior member is not of any such rank, the court shall be dissolved.

(4) Where a court martial is dissolved under the foregoing provisions of this section the accused may be tried by another court martial.

Decisions of  
courts  
martial.

95.—(1) Subject to the provisions of this section, every question to be determined on a trial by court martial shall be determined by a majority of the votes of the members of the court.

(2) In the case of an equality of votes on the finding, the court shall acquit the accused.

(3) A finding of guilty where the only punishment which the court is empowered to award is death shall not have effect unless it is reached with concurrence of all members of the court; and where there is such a finding but no such concurrence, the court shall be dissolved and the accused may be tried by another court.

(4) Where the accused is found guilty and the court has power to sentence him either to death or to some less punishment, sentence of death shall not be passed without the concurrence of all the members of the court.

(5) In the case of an equality of votes on the sentence or on any question arising after the commencement of a trial, except the finding, the president shall have a second or casting vote.

Finding and  
sentence.

96.—(1) Without prejudice to the provisions of section ninety-three of this Act (which authorises the exclusion of the public in certain circumstances) the finding of a court martial on each charge shall be announced in open court; and where the finding of such court is one of guilty the finding shall be, and be announced as being, subject to confirmation.

(2) The sentence of a court martial together with any recommendation to mercy shall be announced in open court, and shall be, and be announced as being, subject to confirmation.

Power to  
convict of  
offence  
other than  
that charged.

97.—(1) Any person charged before a court martial with an offence under this Act may, on failure of proof of the offence having been committed under circumstances involving a higher degree of punishment, be found guilty of the offence as having been committed under circumstances involving a less degree of punishment.

(2) Any person charged before a court martial with any offence may be found guilty of attempting to commit that offence.

(3) Any person charged before a court martial with attempting to commit an offence may be convicted on that charge notwithstanding that it is proved that he actually committed the offence.

(4) Where a person is charged before a court martial under section seventy-four of this Act in respect of attempting to commit a civil offence, he may be convicted on that charge notwithstanding that it is proved that he actually committed the civil offence.

(5) Where a person is charged before a court martial with an offence against section seventy-four of this Act and the corresponding civil offence is one in proceedings for which, if he had been tried by a civil court for committing the offence in Nigeria, he might have been found guilty of another civil offence, then if the court finds that he has committed that other civil offence he may be convicted of an offence against the said section seventy-four in respect of the commission of that other civil offence.

(6) Any person charged before a court martial with an offence specified in the first column of the First Schedule to this Act may be found guilty of an offence specified in relation thereto in the second column of that Schedule.

First  
Schedule.

98.—(1) Unless otherwise prescribed, the rules of evidence to be observed in proceedings before a court martial shall, for the avoidance of doubt, be the same as those observed in the High Court of Lagos ; and accordingly no person shall in proceedings before a court martial be required to answer questions or produce documents which he could not be required to answer or produce in similar proceedings before such High Court.

Rules of  
evidence.

(2) Notwithstanding anything in the last foregoing subsection, a statutory declaration shall, in a trial by court martial, be admissible as evidence of the fact stated therein in a case where and to the extent to which oral evidence to the like effect would be admissible in that trial ; but no statutory declaration shall be admitted in evidence—

(a) if such declaration is tendered on behalf of the prosecution, unless a copy of such declaration has not less than seven days before the commencement of the trial been served on the accused ; or

(b) if such declaration is tendered on behalf of the defence, unless a copy of such declaration has not less than seven days or such lesser period as the commanding officer may allow before the commencement of the trial been served on the commanding officer of the accused ; or

(c) in any case, if not later than three days before the commencement of the trial or within such extended time as the court martial may in the circumstances of the case allow, notice in the prescribed form is served on the accused or, as the case may be, the commanding officer of the accused, requiring oral evidence to be given in substitution for that contained in the statutory declaration ; or

(d) in any case, if the court martial is of opinion that it is desirable in the interests of justice for oral evidence to be given.

(3) Every court martial shall take judicial notice of all matters of notoriety, including matters within the general service knowledge of the court and of all other matters of which judicial notice would be taken in the High Court of Lagos.

Privilege of witnesses and others at courts martial.

99. A witness appearing before a court martial and any other person required to attend such court shall have and be entitled to the same immunities and privileges as are accorded to witnesses in the High Court of Lagos.

Offences by civilians in relation to courts martial.

100.—(1) Where in Nigeria any person other than a person subject to air force law under this Act—

(a) having been duly summoned to attend as a witness before a court martial, fails to comply with the summons ; or

(b) refuses to swear on oath or make an affirmation when duly required by a court martial to do so ; or

(c) refuses to produce any document in his custody or under his control which a court martial has lawfully required him to produce ; or

(d) when a witness refuses to answer any questions which a court martial may lawfully require him to answer ; or

(e) wilfully insults any person, being a member of a court martial or a witness or any other person whose duty it is to attend on or before the court, while that person is acting as a member thereof or is so attending, or wilfully insults any such person as aforesaid while that person is going to or returning from the proceedings of the court ; or

(f) wilfully interrupts the proceedings of a court martial or otherwise misbehaves before the court ; or

(g) does any other thing which would, if the court martial had been a court of law having power to commit for contempt, have been contempt of that court,

the president of the court martial may certify the offence of that person under his hand to the High Court of Lagos, and that court may thereupon inquire into the alleged offence ; and after hearing witnesses (if any) and after taking any statement that may be offered in defence, punish or take steps for the punishment of that person in like manner as if he had been guilty of contempt of the court to which the offence is certified.

(2) In this section "court martial" means a court martial held under service law.

(c) *Confirmation, Revision and Review of Proceedings of Courts Martial*

Confirmation of proceeding of courts martial.

101.—(1) Where a court martial finds the accused guilty of any charge, the record of the proceedings of the court martial shall be transmitted to a confirming authority for confirmation of the findings and sentence of the court on that charge.

(2) Until it is so confirmed, the finding of guilty or, as the case may be, the sentence of a court martial, shall not be treated as the finding or sentence of such court ; but nothing in this subsection shall be construed to prohibit the keeping of the accused in custody pending confirmation or revision of the finding or sentence or the consideration of any petition under this Act.

**102.** At any time after a court martial has sentenced the accused, but not later than the prescribed time after promulgation of confirmation, the accused may, in the prescribed manner, present a petition against the finding or the sentence or both.

Petitions  
against  
finding or  
sentence.

**103.—(1)** A confirming authority may direct that a court martial shall revise any finding of guilty come to by the court in any case where it appears to him—

Revision of  
findings of  
courts  
martial.

(a) that the finding was against the evidence ; or

(b) that some question of law determined at the trial and relevant to the finding was wrongly determined.

(2) Any such direction shall be accompanied by the necessary directions for the reassembly of the court, and shall contain a statement of the reasons for the direction.

(3) On any revision of a finding the court shall reconsider the finding, and (unless the court adheres thereto) may substitute therefor either a finding of not guilty or any other finding to which the court could originally have come at the trial in lieu of the finding under revision.

(4) On any such revision the court shall not have power to receive further evidence.

(5) Where on any such revision the court either adheres to the original finding or substitutes therefor a finding of guilty of another offence, or of the same offence in different circumstances, the court may substitute a different sentence for the original sentence :

Provided that the court shall not have power to substitute a sentence of a punishment greater than the punishment or the greatest of the punishments awarded by the original sentence, or to substitute a sentence which in the opinion of the court is more severe than the original sentence.

(6) The confirming authority shall not have power to direct the revision of any substituted finding of the court on a previous direction of a confirming authority, or the revision of the original finding if adhered to by the court on such a previous direction ; but save as aforesaid this Act shall apply to the proceedings of the court on any such revision (other than the requirement of announcement in open court) as it applies to their deliberation on the original finding or sentence, and any substituted finding or sentence shall be treated for all purposes as an original finding or sentence of the court.

**104.—(1)** Subject to the provisions of section one hundred and three of this Act (which provides for revision of findings) and to the following provisions of this section, a confirming authority shall deal with the finding or sentence of a court martial—

Powers of  
confirming  
authority.

(a) by withholding confirmation, if of the opinion that the finding of the court martial is unreasonable or cannot be supported, having regard to the evidence or to the fact that it involves a wrong decision on a question of law or that on any other grounds there was a miscarriage of justice ; or

(b) by confirming the finding or sentence ; or

(c) by referring the finding or sentence, or both, for confirmation to a higher confirming authority.

(2) Where a confirming authority is of opinion that the facts of the case as considered by the court martial would have justified a finding of guilty by that court on other grounds, the confirming authority may, instead of withholding confirmation of the finding, substitute a finding of guilty on those other grounds and direct whether the punishment should be remitted in whole or in part or be commuted under the provisions of subsection (4) of this section.

(3) Where it appears to a confirming authority that a sentence of a court martial is invalid, the confirming authority may, instead of withholding confirmation of the sentence, substitute therefor a proper sentence of any punishment which might have been awarded by the court, not exceeding or, in the opinion of the confirming authority, more severe than that awarded by the court martial.

(4) If the confirming authority confirms the sentence of a court martial the confirming authority may—

(a) remit in whole or in part any punishment awarded by the court martial, or

(b) commute any punishment so awarded for such other and lesser punishment or punishments as may be prescribed by this Act.

(5) A finding or sentence substituted by the confirming authority, or any sentence having effect after the confirming authority has remitted or commuted punishment, shall be treated for all purposes as a finding or sentence of the court duly confirmed.

(6) The confirmation of a finding or sentence shall not be deemed to be completed until the finding or sentence has been promulgated; and in the event of any such substitution, remission or commutation as aforesaid, the finding or sentence shall be promulgated as it has effect after the substitution, remission or commutation.

(7) Where the confirming authority withholds confirmation under this section, notice thereof shall be promulgated, and it shall have effect as from the date of such promulgation.

**Confirming  
authorities.**

105.—(1) Subject to the provisions of this section, the following persons shall have power to confirm the finding and sentence of any court martial, that is to say—

(a) the officer who convened the court martial or any officer superior in command to that officer; or

(b) the successor of any such officer or superior officer, or any person for the time being exercising the functions of any such officer or superior officer; or

(c) any officer appointed by the air council to act as confirming authority in default of any officer under paragraphs (a) and (b) of this subsection whether for the particular case or for a specified number of cases.

(2) The following persons shall not have power to confirm the finding or sentence of a court martial, that is to say—

(a) any officer who was a member of the court martial; or

(b) any officer who, as commanding officer of the accused, investigated the allegations against him or who is for the time being the commanding officer of the accused; or

(c) any officer who, as appropriate superior authority, investigated the allegations against the accused.

106. A sentence of death passed by a court martial shall not be carried into effect unless approved by the President.

Sentence of death to be approved by the President.

107.—(1) The finding or sentence of a court martial as duly confirmed by a confirming authority may be reviewed,—

Review of findings and sentences of courts martial.

(a) by a reviewing authority consisting of—

(i) the air council or (so far as the delegation extends) any officer to whom the powers of the air council as reviewing authority or any of those powers may be delegated, or

(ii) any officer superior in rank to the confirming authority ; or

(b) in proper case on appeal to or after leave to appeal has been granted by a court of competent jurisdiction ;

and where a case is taken on appeal, the powers of a reviewing authority under paragraph (a) of this subsection, shall cease.

(2) If after confirmation of a finding or sentence a petition under section one hundred and two of this Act is duly presented against the finding or the sentence, or both as the case may be, the finding or sentence shall, subject to the provisions of this section, be reviewed as soon as may be after the presentation of the petition and consideration of its contents.

(3) Where a finding or sentence is reviewed under this section the reviewing authority or the court as the case may require may—

(a) to the extent that the review is of a finding, quash the finding and, if the sentence relates only to the finding quashed, the sentence ; or

(b) in any case, exercise the like powers of substituting findings, or valid sentences for invalid sentences, or of remitting or commuting punishment as are conferred on a confirming authority under this Act, and any substituted finding or sentence, or sentence having effect after the remission or commutation of punishment, shall be treated for all purposes as a sentence of the court martial duly confirmed.

(4) Any finding or sentence reviewed under this section shall be promulgated and shall have effect as from the date of such promulgation.

108.—(1) Sentences of imprisonment passed by courts martial may be reconsidered by the commander or by such officers (not below the rank of group captain or corresponding rank) as may be from time to time appointed by the President ; and if on any such reconsideration it appears that the conduct of the offender since his conviction has been such as to justify remission of the sentence, whether in part or in whole, it may be remitted accordingly.

Reconsideration of sentences of imprisonment.

(2) The power to reconsider a sentence may be exercised at any time after confirmation, and where, after review, (if any) a sentence remains effective it shall be reconsidered at intervals of six months ; but no delay in complying with this section at any such interval shall invalidate the sentence.

*Review of Summary Findings and Awards*

Review of  
summary  
findings and  
awards.

109.—(1) Where a charge has been dealt with summarily and the charge is not dismissed, the air council or any officer superior in command to the officer who dealt summarily with the charge, shall be the authority to review the finding or award at any time.

(2) Where by reason of any mistake of law in the proceedings on the summary dealing with the charge or of anything occurring in those proceedings the reviewing authority is satisfied there has been a substantial injustice to the accused, that authority may quash the finding and any award on the finding.

(3) Where on a review under this section it appears to the said authority that a punishment awarded was invalid, or too severe, or (where the award included two or more punishments) that those punishments or some of them could not validly have been awarded in combination or are, taken together, too severe, the authority may vary the award by substituting such punishment or punishments as the authority may think proper, being a punishment or punishments which could have been included in the original award and not being in the opinion of the authority more severe than the punishment or punishments included in the original award.

(4) If the confirming authority confirms the award, the confirming authority may—

(a) remit in whole or in part any punishment awarded, or

(b) commute any punishment so awarded for such other and lesser punishment or punishments as may be prescribed by this Act.

(5) A finding or sentence substituted by the confirming authority, or any sentence having effect after the confirming authority has remitted or commuted punishment, shall be treated for all purposes as a finding or sentence duly confirmed.

(6) The confirmation of a finding or sentence shall not be deemed to be completed until the finding or sentence has been promulgated; and in the event of any such substitution, remission or commutation as aforesaid the finding or sentence shall be promulgated as it has effect after the substitution, remission or commutation.

(7) Where the confirming authority withholds confirmation under this section, notice thereof shall be promulgated, and it shall have effect as from the date of such promulgation.

*Findings of Insanity, etc.*

Provisions  
where  
accused  
found  
insane.

110.—(1) Where, on the trial of a person by court martial, it appears to the court that the accused is by reason of insanity unfit to stand his trial, the court shall so find; and if the finding is confirmed in accordance with the following provisions of this section the accused shall be kept in custody in such manner as may be provided by or under rules made under this Part of this Act until the directions of the President are known or until any earlier time at which the accused is fit to stand his trial.

(2) Where, on the trial of a person by court martial, it appears to the court that the evidence is such as, apart from any question of insanity, to support a finding that the accused was guilty of any offence, but that at the time of the acts of omissions constituting that offence the accused was by reason of mental disease or natural mental infirmity not criminally responsible for the act or omission alleged as constituting the offence, the court shall find that the accused committed the act or omission but was insane at the said time, and thereupon the accused shall be kept in custody in such manner as may be provided by or under rules made under this Part of this Act until the directions of the President are known.

(3) In the case of any such finding as aforesaid the President may give orders for the safe custody of the accused during his pleasure in such place and in such manner as the President thinks fit.

(4) A finding under subsection (1) of this section shall not have effect unless and until the finding has been confirmed by the authority having power to confirm a finding of guilty by the court martial in question and the finding has been promulgated.

(5) Where the court or the confirming authority comes to or substitutes a finding under subsection (2) of this section the confirming authority or, as the case may be, the reviewing authority shall not have power to substitute for that finding a finding of guilty; but save as aforesaid the provisions of this Act as to revision, confirmation and review (and in particular the provisions of this Act which confer power to substitute for any finding any other finding which could have been come to by the court martial in question) shall apply in relation to such findings as are provided for by subsection (2) of this section as those provisions apply in relation to findings of guilty.

(6) Unless otherwise provided in this Act or the context requires a different construction, references in this Act to a conviction or a finding of guilty in respect of any offence include references to findings under subsection (2) of this section in respect of the offence.

#### *Commencement, Suspension and Duration of Sentences*

111. Save as otherwise provided in this Act, a sentence of imprisonment or field punishment shall begin to run from the beginning of the day on which sentence was originally pronounced by the court martial trying the offender or, as the case may be, was originally awarded by his commanding officer.

Commencement of sentences.

112.—(1) Where any person serving a sentence of imprisonment under this Act becomes unlawfully at large during the currency of the sentence, then, in calculating the period for which he is liable to be imprisoned in pursuance of the sentence, no account shall be taken of time elapsing during the period beginning with the day on which he became at large and ending with the day on which, as a person having become unlawfully at large, he is taken into air force custody or the custody of a civil authority or (not having been taken into such custody) returns to the place in which he was imprisoned before he became unlawfully at large :

Duration of sentences of imprisonment.

Provided that if he satisfies such authority as may be specified in that behalf by or under Imprisonment Rules that during any time during the last-mentioned period he was—

(a) in the custody of a civil authority ; or

(b) if and in so far as Imprisonment Rules so provide, in the custody of any air force authority of any country or territory outside Nigeria as respects which arrangements have been made under section one hundred and fourteen of this Act,

otherwise than an account of an offence committed by him while unlawfully at large, the last-mentioned time shall not be disregarded in calculating the period for which he is liable to be imprisoned or detained in pursuance of the sentence imposed under this Act.

(2) In subsection (1) of this section the expression "civil authority" means a civil authority (whether of the Federation or of any country or territory outside Nigeria) authorised by law to detain persons, and includes a police officer.

(3) Without prejudice to the provisions of subsection (1) of this section, where any person serving a sentence of imprisonment has in accordance with Imprisonment Rules been temporarily released on compassionate grounds, then, in calculating the period for which he is liable to be imprisoned in pursuance of the sentence, no account shall be taken of time elapsing during the period beginning with the day after that on which he is released and ending with the day on which he is required to return to custody.

(4) A person who for any period is released as mentioned in subsection (3) of this section or who is otherwise allowed, in pursuance of Imprisonment Rules, out of air force custody for any period or subject to any condition shall, on failure to return at the expiration of the period or to comply with the condition, be treated for the purposes of subsection (1) of this section as being unlawfully at large.

(5) A person serving a sentence of imprisonment in civil custody who, after being temporarily released under the civil law of the country or territory in which he is serving his sentence, is at large at any time during the period for which he is liable to be detained in civil custody in pursuance of his sentence, shall be deemed to be unlawfully at large if the period for which he was temporarily released has expired, or if an order recalling him has been made in pursuance of the civil law of such country or territory.

*Air force prisoners in civil prisons.*

113. Where a person is sentenced to death or to imprisonment and is committed or transferred to a civil prison in pursuance of rules made under this Part of this Act, or of Imprisonment Rules, he shall, while in that prison, be confined and otherwise dealt with in the same manner as a person confined therein under a like sentence of a civil court.

114. The Minister may from time to time make arrangements with the authorities of any country or territory outside Nigeria whereby sentences of death passed by courts martial may in accordance with rules made under this Part of this Act be carried out in establishments under the control of those authorities and air force sentences of imprisonment or detention may, in accordance with Imprisonment Rules, be served wholly or partly in such establishments.

*Special provisions as to carrying out or serving of sentences outside Nigeria.*

**115.—(1)** A person who is serving a sentence of imprisonment in Nigeria may, in so far as may be specified by or under Imprisonment Rules, be removed out of Nigeria to any place where the unit or any part thereof to which for the time being he belongs is serving or is under orders to serve, but not to any other place.

Country in which sentence of imprisonment to be served.

(2) Subject to the following provisions of this section, a person sentenced under this Act, by a court martial held out of Nigeria, to imprisonment for more than twelve months shall as soon as practicable after the confirmation of the sentence is completed be removed to Nigeria.

(3) Where a person has been sentenced under this Act, by a court martial held out of Nigeria, to imprisonment for more than twelve months, the confirming authority or reviewing authority may, notwithstanding anything in subsection (2) of this section, direct that he shall not be required to be removed to Nigeria until he has served such part of his sentence, not exceeding two years, as may be specified in the direction; and in determining whether or not to exercise the powers conferred by this subsection, a confirming authority or reviewing authority shall have regard to any recommendation in that behalf made by the court martial.

(4) Any direction of a confirming authority under this section may at any time be revoked by the confirming authority or by a reviewing authority, or may be superseded by any direction of the confirming authority or a reviewing authority which either authority might have given under subsection (3) of this section; and any direction of a reviewing authority under this section may at any time be revoked by a reviewing authority or be superseded as aforesaid.

(5) Any direction given under this section, and the revocation of any such direction, shall be promulgated.

(6) In ascertaining at any time for the purposes of this section the nature or length of a sentence regard shall be had to any commutation or remission of the sentence previously directed.

**116.—(1)** It shall be the duty, in so far as rules made under this Part of this Act or Imprisonment Rules so provide, of the superintendent or other person in charge of a prison (not being an air force prison) to receive any person duly sent to that prison in pursuance of any such rules and to confine him until execution of the sentence is completed or the prisoner is discharged or delivered over in due course of law.

Duties of persons in charge of prisons and others to receive prisoners.

(2) Where a person is in air force custody in pursuance of a sentence of imprisonment, then on receipt of a written order in that behalf purporting to be signed by that person's commanding officer it shall be the duty of any such superintendent or other person as aforesaid, or the police officer in charge of a police station or of any person in charge of any other place in which prisoners may be lawfully confined to keep that person in custody for a period not exceeding seven days unless the said person is earlier discharged or delivered over in due course of law.

*Trial and Time Limit of Persons ceasing to be subject to Air Force Law*

Trial, etc.  
of offences  
although  
offender no  
longer  
subject to  
Act.

117.—(1) Subject to the provisions of this Act whereby a time limit for prosecution of offences may be prescribed, where an offence triable by court martial has been or is reasonably suspected of having been committed by any person who, before arrest or trial as the case may be, ceases to be subject to air force law under this Act, then in relation to that offence he shall be treated for all purposes of this Act relating to trial and punishment as if he were still a member of the air force, and may be dealt with accordingly.

(2) Where at any time before or after trial any person in custody by virtue of this section commits, or is reasonably suspected of having committed an offence which, if he were subject to air force law under this Act would be an offence under this Act triable by court martial he shall, in relation to that offence or suspected offence, be treated for the purposes of trial and punishment as if he were still subject to air force law under this Act as a member of the air force at the time of the commission of suspected commission of the offence and as thereafter continuing subject thereto.

(3) If under the provisions of this section a person is treated as continuing to be subject to air force law under this Act, for the purpose of trial and punishment, the provisions of such law shall apply to him—

(a) if he holds any air force rank, as to a person having that rank ;

(b) if he no longer holds air force rank, as if he was of the rank he had when last actually subject to air force law under this Act :

Provided that if he is sentenced in respect of the offence in question and the sentence is confirmed, the provisions of such law shall at any time thereafter in any case have effect and apply to him as they would to an airman.

(4) Where apart from this subsection any provisions of this Act would under subsection (3) of this section apply to a person in relation to different offences as to a person having two or more different ranks in the air force, it shall apply to him as to a person having the lower or lowest of those ranks, as the case may be.

Limitation of  
time for  
trial of  
offences  
under this  
Act.

118.—(1) No person shall be tried by court martial for any offence (other than mutiny, failure to suppress mutiny, or the offence of desertion) unless the trial is begun within three years after the commission of the offence, regard not being had to any period of time during which that person was a prisoner of war or was illegally absent :

Provided that—

(a) in the case of an offence against section seventy-four of this Act (which relates to civil offences) where proceedings for the corresponding civil offences are, by virtue of any written law, to be brought within a limited time, that limit of time shall apply to the trial of the offence under the said section seventy-four in substitution for the foregoing provisions of this subsection ;

(b) a person may, subject to any time limit prescribed by any written law mentioned in the foregoing paragraph (a) and to the consent of the Attorney-General of the Federation, be tried by court martial for a civil offence committed outside Nigeria notwithstanding that it was committed more than three years before the beginning of the trial.

(2) Where a person who has committed an offence of desertion (other than desertion on active service) has since the offence served as an airman of the regular air force continuously in an exemplary manner to the satisfaction of his immediate commanding officer or commanding officers, as the case may be, for not less than three years, he shall not be tried for that offence.

(3) A person shall not be triable by virtue of subsection (1) of section one hundred and seventeen of this Act (which relates to offences by persons deemed to continue to be subject to air force law) unless his trial is begun within three months after he ceases to be subject to air force law under this Act, or the trial is for a civil offence committed outside Nigeria and the Attorney-General of the Federation consents to the trial; but nothing in this subsection shall apply to offences of mutiny, failure to suppress mutiny or desertion.

(4) A person shall not be arrested or kept in custody by virtue of subsection (1) of section one hundred and seventeen of this Act for an offence at any time after he has ceased to be triable for the offence.

*Relations between Air Force and Civil Courts and Finality of Trials*

**119.—(1)** Subject to the provisions of this Act restricting further trial of an offence, where conviction for an offence is duly quashed under air force law, nothing in this Act shall restrict the offences for which persons may be tried by any civil court, or the jurisdiction of any civil court to try a person subject to air force law under this Act, for any offence.

Powers of  
civil courts.

(2) Where a person is tried by a civil court for any offence, and he has, in pursuance of this Act, been punished for any act or omission constituting (whether wholly or in part) that offence by his commanding officer or an appropriate superior authority, the civil court shall, in awarding punishment, have regard to his punishment in pursuance of this Act.

**120.—(1)** Where a person subject to air force law under this Act—

(a) has been tried for an offence by a competent civil court or a court martial under service law; or

(b) has been charged with an offence under service law, and has had the charge dismissed, or has been found guilty on the charge, by his commanding officer or an appropriate superior authority; or

(c) has had an offence condoned by his commanding officer,

he shall not be liable in respect of that offence to be tried by court martial or to have the case dealt with summarily by his commanding officer or an appropriate superior authority.

Offences  
already  
disposed of  
not to be  
retried.

(2) For the purposes of this section—

(a) a person shall not be deemed to have been tried by a court martial if confirmation is withheld of a finding by the court martial that he is guilty of the offence;

(b) a case shall be deemed to have been dealt with summarily by a commanding officer or an appropriate superior authority notwithstanding that the finding of that officer or authority has been quashed, or the award of that officer or authority quashed or varied on the review thereof;

(c) an offence shall be deemed to have been condoned by the commanding officer of a person alleged to have committed the offence if, and only if, that officer or any officer authorised by him to act in relation to the alleged offence has with knowledge of all relevant circumstances informed him that he will not be charged therewith ;

(d) a person ordered under subsection (2) of section sixty-two of this Act, or the corresponding provisions of any service law, to be imprisoned or to undergo detention for an offence against that section or provision shall be deemed to have been tried by court martial for the offence.

(3) Where confirmation of a finding of guilty of an offence is withheld the accused shall not be tried again by court martial for that offence unless the order convening the later court martial is issued not later than twenty-eight days after the promulgation of the decision to withhold confirmation.

(4) Save as provided in the foregoing provisions of this section, proceedings for an offence against this Act (whether before a commanding officer or an appropriate superior authority or before a court martial) shall not be barred on the ground of condonation.

#### *Inquiries*

Boards of  
inquiry.

121.—(1) Subject to and in accordance with the provisions of rules made under this Part of this Act (hereinafter referred to as “Boards of Inquiry Rules”), the air council or any air force officer commanding a body of air force personnel may convene a board of inquiry to investigate and report on the facts relating to any matter which may be referred to such board by the air council or any such officer as aforesaid ; and a board of inquiry shall, if directed so to do, express thier opinion on any question arising out of any matters referred to the board.

(2) A board of inquiry shall consist of such number of persons as may be provided for by the Boards of Inquiry Rules, who shall be persons subject to service law ; and the president of a board of inquiry shall be an officer not below the rank of flying officer or corresponding rank.

(3) Evidence given before a board of inquiry shall not be admissible against any person in proceedings before a court martial, commanding officer or appropriate superior authority other than in proceedings for an offence against section sixty-three of this Act or for an offence against section seventy-four of this Act when the corresponding civil offence is perjury.

(4) The power to make Boards of Inquiry Rules shall be exercisable by the air council.

Inquiries  
into absence.

122.—(1) Where a board of inquiry inquiring into the absence of an officer or airman reports that he has been absent without leave or other sufficient cause for a period specified in the report, not being less than twenty-one clear days, a record of the report shall in accordance with Boards of Inquiry Rules be entered in the service books.

(2) A record entered in pursuance of subsection (1) of this section shall, unless the absentee subsequently surrenders or is arrested, or the report of the board of inquiry is annulled by the air council or a subsequent board of inquiry, have the like effect as a conviction by court martial for desertion.

*Miscellaneous Provisions*

123.—(1) The following provisions of this section shall have effect where a person has been convicted by court martial of unlawfully obtaining any property, whether by stealing it, receiving it or retaining it knowing or having reason to believe it to have been stolen, fraudulently misapplying it or otherwise.

Restitution  
or compensa-  
tion for theft,  
etc.

(2) If any of the property unlawfully obtained has been found in the possession of the offender, it may be ordered to be delivered or paid to the person appearing to be the owner thereof.

(3) If there has been found in the possession of the offender any property (other than money) appearing to have been obtained by him by the conversion or exchange of any of the property unlawfully obtained, the property may be ordered to be delivered to the person appearing to be the owner of the property unlawfully obtained.

(4) Where money is found in the possession of the offender, then whether or not it appears to have been obtained as aforesaid an order may be made that there shall be paid out of that money to the person appearing to be the owner of the property unlawfully obtained such sum as may be specified in the order as or towards compensation for the loss caused to the said person by the offence, in so far as not otherwise made good under this Act or by the recovery of the property unlawfully obtained.

(5) Where any of the property unlawfully obtained has been sold or given in pawn to some other person who did not then know it to have been unlawfully obtained, an order may be made that, subject to the restitution to the owner thereof of the property sold or given as aforesaid, there shall be paid to the said other person out of any money found in the possession of the offender (whether or not the money appears to be proceeds of the sale or giving in pawn), such sum as may be specified in the order as or towards compensation for the loss caused to him in consequence of the sale or giving in pawn.

(6) Where any of the property unlawfully obtained has been given in exchange to some other person who did not then know it to have been unlawfully obtained, an order may be made, that, subject to the restitution to the owner thereof of the property given as aforesaid, there shall be restored to the said other person the property taken in exchange for the property unlawfully obtained.

(7) An order under this section may be made by the court martial by whom the offender is convicted, by the confirming authority, or by any reviewing authority; and in this section the expression "appearing" means appearing to the court or authority making the order.

(8) An order under this section made by a court martial shall not have effect until confirmed by the confirming authority and the provisions of this Part of this Act as to the confirmation and review of the proceedings of courts martial shall apply to an order under this section as they apply to a sentence.

(9) The operation of any order under this section shall be suspended—

(a) in any case, until the expiration of the period prescribed under Part V of this Act as the period within which an application for leave to appeal to the Supreme Court against the conviction must be lodged; and

(b) if such an application is duly lodged, until either the application is finally refused or is withdrawn or the appeal is determined or abandoned;

and where the operation of such an order as aforesaid is suspended under this section—

(i) it shall not take effect if the conviction is quashed on appeal;

(ii) the Supreme Court may by order annul or vary the order although the conviction is not quashed;

(iii) such steps shall be taken for the safe custody, during the period when the operation of the order is suspended, of the property ordered to be restored or handed over or the money to which the order relates as may be provided by rules of court made under the said Part V.

(10) Notwithstanding anything in subsection (9) of this section, an order under this section shall not, so far as it relates to the delivery of property to the person appearing to be the owner thereof, be suspended if the court or authority making the order directs to the contrary in any case in which, in the opinion of the court or authority, the title to the property is not in dispute.

(11) An order under this section shall not bar the right of any person, other than the offender or a person claiming through him, to recover any property delivered or paid in pursuance of such an order from the person to whom it is delivered or paid.

Appointment  
of judge  
advocates.

124. Without prejudice to the powers conferred by the President on the Judge Advocate General, the appointment of a judge advocate to act at any court martial may, failing the making thereof by or on behalf of the Judge Advocate General, be made by the convening officer.

Promulga-  
tion.

125. Any finding, sentence, determination or other thing required by this Act to be promulgated shall be promulgated either by being communicated to the accused or as the confirming or reviewing authority, as the case may be, may direct.

Custody of  
proceedings  
of courts  
martial and  
right of  
accused to a  
copy thereof.

126.—(1) The record of the proceedings of a court martial shall be kept in the custody of the commander for not less than the prescribed period, being a period sufficient to ensure that the rights conferred by subsections (2) and (3) of this section shall be capable of being exercised.

(2) Subject to the provisions of this section, any person tried by a court martial shall be entitled to obtain from the commander on demand at any time within the relevant period and on payment therefor at such rate as may be prescribed a copy of the record of the proceedings of the court.

(3) Where a person tried by court martial dies within the relevant period, his personal representatives or any person who in the opinion of the commander ought to be treated for the purposes of this subsection as his personal representative shall, subject to the provisions of this section, be entitled to obtain from the commander on demand at any time within the period of twelve months from the death and on payment therefor at the prescribed rate a copy of the record of the proceedings of the court.

(4) If, on an application in pursuance of either subsection (2) or subsection (3) of this section for a copy of the record of any proceedings, the Minister certifies that it is requisite for reasons of security that the proceedings or any part thereof should not be disclosed, the applicant shall not be entitled to a copy of the proceedings or part to which the certificate relates.

(5) In this section the expression "the relevant period", in relation to any person tried by court martial, means the period of five years beginning with the date of his acquittal or, where he was convicted, of the promulgation of the finding and sentence or, where a finding of guilty was not confirmed, of the promulgation of the withholding of confirmation :

Provided that where the proceedings relate to two or more charges and the person tried was acquitted on one or more of the charges and convicted on another or others, the relevant period shall be the period of five years beginning with the date of the promulgation of the findings of guilty and the sentence thereon or of the withholding of confirmation of that finding, or those findings.

(6) Any reference in this section to the record of the proceedings of a court martial includes a reference to the record of the proceedings with the respect to the confirmation or revision of the findings and sentence of the court martial.

127. No action shall lie in respect of anything done by any person in pursuance of an air force sentence of imprisonment if the doing thereof would have been lawful but for a defect in any warrant or other instrument made for the purposes of that sentence.

Indemnity  
for prison  
officers, etc.

#### *Redress of Complaints*

128.—(1) If an officer thinks himself wronged in any matter by a superior officer or authority and on application to his commanding officer he does not obtain the redress to which he thinks he is entitled, he may make a complaint with respect to that matter to the air council.

Complaints  
by officers.

(2) On receiving any such complaint it shall be the duty of the air council to investigate the complaint and to grant any redress which appears to the air council to be necessary or if the nature of the complaint so requires, the air council shall report the complaint to the Minister for the directions (if any) of the President.

129.—(1) If an airman thinks himself wronged in any matter by any officer other than his commanding officer or by any airman, he may make a complaint with respect to that matter to his commanding officer.

Complaints  
by airmen.

(2) If an airman thinks himself wronged in any matter by his commanding officer, either by reason of redress not being given to his satisfaction on a complaint under subsection (1) of this section or for any other reason, he may make a complaint with respect thereto to any military, naval or air force officer under whom the complainant is for the time being serving, being an officer not below the rank of air commodore or corresponding rank.

(3) It shall be the duty of a commanding officer or other officer to have any complaint received by him under this section investigated and to take steps for redressing the matter complained of, which appear to him to be necessary.

*Rules of Procedure, etc.*

130.—(1) The President may make rules of procedure generally for the purposes of this Part of this Act, and without prejudice to the generality of the foregoing, rules may be made—

(a) for the convening, constitution and conduct of courts martial ;

(b) with respect to the execution of sentences of death under this Act, including the manner and place where such executions are to be carried out and the custody, treatment and removal of persons under sentence of death ;

(c) for the execution of sentences of imprisonment including the prisons, civil or otherwise, in which they are to be served, the classification, treatment, employment, discipline, control, removal and temporary release on compassionate grounds of persons serving such sentences and the appointment, powers and duties of inspectors, visitors, governors and other members of the staff and officers in charge of persons serving sentences of imprisonment ;

(d) with respect to field punishment ;

(e) for the convening, constitution and procedure of boards of inquiry, the rules of evidence to be observed and the taking of evidence by such boards, including the administration of oaths and affirmations to witnesses and the making of reports by such boards ;

(f) in respect of matters for which rules may be made under the foregoing provisions of this Part of this Act ;

(g) for such incidental and supplementary matters as appear requisite for the purpose of the foregoing.

(2) Until such time as rules of procedure are made under this section, the rules of procedure prescribed for or used by the military forces of Nigeria may be used for the purposes of this Act with such adaptations, modifications and exceptions as may be necessary to give effect thereto.

*Interpretation of this Part*

131.—(1) In this Part—

“air force prison” means separate premises designated by the commander for persons serving air force sentences of imprisonment ;

“civil prison” means a prison in Nigeria in which a person sentenced by a civil court to imprisonment can for the time being be confined ;

Rules of procedure and other rules.

Interpretation of Part IV.

"convening officer", in relation to a court martial, means the officer convening that court martial and includes his successor or any person for the time being exercising his or his successor's functions ;

"prescribed" means prescribed by Rules of Procedure ;

"prison" includes a civil prison and any military, naval or air force prison.

(2) References in this Part of this Act to a sentence of imprisonment or to an air force sentence of imprisonment, shall include references to a sentence of imprisonment passed by a court martial or to such a sentence awarded by a commanding officer.

(3) References in this Part of this Act to detention or to air force sentences of detention shall include references to detention passed by a court martial or to any such sentence by the offender's commanding officer.

(4) References in this Part of this Act to warrant officers do not include references to acting warrant officers.

(5) References in this Part of this Act to non-commissioned officers include references to acting non-commissioned officers and also to acting warrant officers.

#### PART V—APPEALS FROM COURTS MARTIAL

132. Subject to the following provisions of this Part of this Act, an appeal shall lie from decisions of a court martial to the Supreme Court with the leave of the Supreme Court :

Right of appeal.

Provided that an appeal as aforesaid shall lie as of right without the leave of the Supreme Court from any decision of a court martial involving a sentence of death.

133.—(1) Leave to appeal against the finding of a court martial may be granted by the Supreme Court on application made to it by the appellant in the prescribed form setting out the grounds on which leave to appeal is sought and such other particulars (if any) as may be prescribed, and lodged with the registrar of that court or if rules of court otherwise allow, lodged with any other person.

Procedure for applying for leave to appeal or lodging appeal.

(2) The application shall, in the case of any finding involving a sentence of death, be lodged within ten days of the date of promulgation of the finding, and in any other case within forty days thereof.

(3) The Supreme Court may extend the period within which application for leave to appeal is made in respect of any finding other than one involving a sentence of death, and whether or not the said period of forty days has expired.

(4) Rules of court may provide that, in such circumstances as may be specified therein, any application for leave to appeal or the appeal itself may, when lodged with such person other than the registrar as may be specified in such rules, be treated for the purposes of this section as having been duly lodged with the registrar.

(5) In considering whether or not to grant leave to appeal, the Supreme Court shall have regard to any opinion expressed by the judge advocate, if any, who acted at the court martial on the merits of the case as one for appeal.

(6) Where the Supreme Court dismisses an application for leave to appeal it may, if it considers the application to have been frivolous or vexatious, order that any sentence passed upon the applicant in the proceedings from which it was sought to bring the appeal shall begin to run from the day on which the Court dismisses the application.

Determina-  
tion of  
appeals in  
ordinary  
cases.

134.—(1) Subject to the provisions of this and the next succeeding section, the Supreme Court shall allow an appeal against a conviction if it thinks that the finding of the court martial is unreasonable or cannot be supported having regard to the evidence or that it involves a wrong decision on a question of law, or that there was a miscarriage of justice ; and in any other case the Supreme Court shall dismiss the appeal.

(2) Notwithstanding the provisions of the foregoing subsection, the Supreme Court may dismiss an appeal if of the opinion that the point raised in the appeal might be decided in favour of the appellant, but no substantial miscarriage of justice has occurred.

(3) If the Supreme Court allows an appeal against a conviction under this Part of this Act it shall quash the conviction.

(4) On an appeal under this Part of this Act against sentence the Supreme Court shall, if it is of opinion that a different sentence should have been passed, quash the sentence passed by the court martial and pass such other sentence (whether more or less severe) in substitution therefor as it thinks ought to have been passed, being a sentence which under section seventy-five or section seventy-six of this Act, could lawfully have been passed for the offence of which the appellant was convicted or, if it is not of opinion that a different sentence should have been passed, it shall dismiss the appeal.

(5) The term of any sentence imposed by the Supreme Court under subsection (4) of this section shall, unless that court otherwise directs, begin to run from the time from which it would have begun to run if it had been imposed in the proceedings from which the appeal was brought, and any such sentence shall be deemed for the purposes of this Act to be a sentence passed by the court martial and duly confirmed.

Powers of  
the Supreme  
Court in  
special  
cases.

135.—(1) If it appears to the Supreme Court that an appellant, though not properly convicted on some charge preferred against him before the court martial by which he was tried, was properly convicted on some other charge so preferred, then, if the sentence passed by the court martial on the appellant was not one which could lawfully be passed by the court martial for the offence of which he was convicted on the other charge, the Supreme Court shall pass on the appellant, in substitution for the sentence passed on him by the court martial, such sentence as it thinks proper, being a sentence which, under section seventy-five or section seventy-six of this Act, could lawfully have been passed in respect of the charge on which the appellant was properly convicted, but not being a sentence of greater severity.

(2) Where an appellant has been convicted of an offence and the court martial by which he was tried could lawfully have found him guilty of some other offence, and it appears to the Supreme Court that the court martial must have been satisfied of facts which proved him

guilty of that other offence, the Supreme Court may, instead of allowing or dismissing the appeal, substitute for the finding of the court martial a finding of guilty of the other offence and pass on the appellant, in substitution for the sentence passed on him by the court martial, such sentence as it thinks proper, being a sentence, which, under section seventy-five or section seventy-six of this Act could lawfully have been passed for that other offence but not being a sentence of greater severity.

(3) Where—

(a) an appellant has been convicted of an offence committed under circumstances involving the higher of two degrees of punishment, and it appears to the Supreme Court that the court martial by which he was tried ought to have found him guilty of the offence as being committed under circumstances involving the lower degree of punishment; or

(b) an appellant has been convicted of an offence and it appears to the Supreme Court that the court martial by which he was tried ought to have found him guilty of the offence subject to exceptions or variations,

the Supreme Court may, instead of allowing or dismissing the appeal substitute for the finding of the court martial a finding of guilty of the offence as being committed under circumstances involving the lower degree of punishment or, as the case may be, guilty of the offence subject to exceptions or variations and pass on the appellant, in substitution for the sentence passed on him by the court martial, such sentence as it thinks proper, being a sentence which, under section seventy-five or section seventy-six of this Act, could lawfully have been passed for the offence specified or involved in the substituted finding, but not being a sentence of greater severity.

(4) If, on an appeal, it appears to the Supreme Court that, although the appellant committed the act or omission charged against him, he was insane at the time the act was done, or the omission made, so as not to be responsible according to law for his actions, the Supreme Court may quash the sentence passed at the trial and order the appellant to be kept in custody under the provisions of section one hundred and ten of this Act, in like manner as on a special finding of insanity by the court martial by which the appellant was convicted.

(5) The term of any sentence imposed by the Supreme Court under any of the foregoing provisions of this section shall, unless that court otherwise directs, begin to run from the time from which it would have begun to run if it had been passed in the proceedings from which the appeal was brought, and any such sentence shall be deemed for the purposes of this Act to be a sentence imposed by the court martial and duly confirmed.

136. The determination by the Supreme Court of any appeal or other matter which it has power to determine under the provisions of this Part of this Act shall be final.

Appeals to be final.

137. For the purposes of this Part of this Act the Supreme Court may, if it thinks it necessary or expedient in the interests of justice, appoint any person with special expert knowledge to act as assessor in any case where it appears to the Supreme Court that such special knowledge is required for the proper determination by it of the case.

Supplementary powers of the Supreme Court.

Proceedings to be heard in absence of appellants.

138. An appellant shall not be entitled to be present at the hearing of an appeal to the Supreme Court under this Part of this Act or at any proceedings preliminary or incidental to such an appeal except where rules of court provide that he shall have the right to be present or the Supreme Court gives him leave to be present, and accordingly any power of the Supreme Court under this Part of this Act to pass a sentence may be exercised notwithstanding the absence of the appellant.

Defence of appeals.

139. It shall be the duty of the air council on an appeal against a decision of a court martial to arrange for the defence of the appeal.

Right of appellant to present his case in writing.

140. An appellant may, if he so desires, instead of presenting his case orally, present it in writing in the prescribed form.

Suspension of death sentences.

141. Where a conviction by court martial involves sentence of death, the sentence shall not in any case be executed until the expiration of the period within which an appeal to the Supreme Court against the conviction may be lodged; and if any such appeal is lodged the sentence shall not be executed pending the determination or dismissal of the appeal, or as the case may be, the appeal is abandoned.

Persons not to be tried again where conviction quashed.

142. Where the conviction of a person by a court martial for an offence has been quashed under this Part of this Act, he shall not be liable to be tried again for that offence by a court martial or by any other court.

Removal of prisoners for purposes of proceedings.

143. Imprisonment Rules may provide in what manner an appellant, when in custody, is to be taken to, kept in custody at, and brought back from any place at which he is entitled to be present for the purposes of this Part of this Act or any place to which the Supreme Court or a justice thereof may order him to be taken for the purpose of any proceedings of the Supreme Court.

Furnishing, on appeal, of documents relating to trial.

144. In the case of every appeal, or application for leave to appeal, under this Part of this Act to the Supreme Court against a decision of a court martial, it shall be the duty of the commander to furnish to the registrar of the Supreme Court, in accordance with rules of court, the proceedings of the court martial (including any proceedings with respect to the revision of the findings or sentence of the court martial in pursuance of subsection (1) of section one hundred and three of this Act with respect to the confirmation of the finding and sentence of the court martial).

Duties of registrar of the Supreme Court in respect of appeals, etc.

145.—(1) The registrar of the Supreme Court shall furnish the necessary forms and instructions relating to appeals or applications for leave to appeal under this Part of this Act to any person requiring them, to persons in charge of places where persons sentenced by court martial may lawfully be confined for the purpose of serving their sentences, and to such other persons as the registrar thinks fit; and every person in charge of such a place as aforesaid shall cause the forms and instructions to be placed at the disposal of persons confined in that place who desire to lodge an appeal or make application for leave to appeal under this Part of this Act.

(2) The registrar of the Supreme Court shall forthwith upon receipt of an appeal or application for leave to appeal under this Part of this Act, obtain and lay before the Supreme Court in proper form all documents, exhibits and other things relating to the proceedings in the court martial by which the appellant or applicant was tried, which appear necessary for the proper determination of the appeal or of the application, as the case may be.

146.—(1) The Chief Justice of Nigeria may make rules of court for regulating the procedure and practice to be followed in the Supreme Court for the purposes of this Part of this Act.

Rules of court.

(2) Rules of court made for the purposes of any provision of this Part of this Act may make different provision in relation to different classes of cases and may provide for any incidental or supplementary matters for which it appears to the Supreme Court to be necessary or expedient for the purposes of that provision to provide.

(3) Reference in this Part of this Act to "prescribed" shall be to any matter or thing prescribed by rules of court.

147. Nothing in this Part of this Act shall—

(a) affect the exercise by reviewing authorities of the powers conferred upon them by section one hundred and seven of this Act in respect of a decision of a court martial so far as regards the exercise by them of those powers at any time before the lodging with the registrar of the Supreme Court of an appeal or an application for leave to appeal, as the case may be, against the decision ; or

Saving of reviewing authorities' powers.

(b) affect the exercise by the President of the prerogative of mercy under the Constitution of the Federation.

148. Upon the hearing of any appeal from a court martial the Supreme Court shall consist of at least three Justices.

Composition of court.

149. Notwithstanding the provisions of section one hundred and forty-eight of this Act, any Justice of the Supreme Court may—

(a) give leave to appeal, or

(b) extend the time limit within which an application for leave to appeal otherwise than in the case of sentence of death may properly be lodged under section one hundred and thirty-three of this Act, or

(c) allow an appellant to be present at any proceedings under this Part of this Act,

Exercise of certain powers of the Supreme Court by a Justice.

but nothing in this section shall be construed to preclude the hearing and determination of any such application if a Justice refuses the application, and accordingly the appellant or applicant, as the case may be, shall be entitled, notwithstanding such refusal, to have the application dealt with before the Supreme Court sitting with not less than three Justices under the provisions of said section one hundred and forty-eight.

150. Subject to the provisions of this Part of this Act and to any rules of court made thereunder, the provisions of the Federal Supreme Court Act, 1960, relating to the hearing of appeals from subordinate courts shall apply to the hearing and determination of an appeal under this Part of this Act.

General provisions as to procedure. No. 26 of 1960.

## PART VI—PAY, FORFEITURES AND DEDUCTIONS

Regulations  
as to pay.

151. The President may make regulations governing the pay, allowances and other emoluments of the officers and airmen of the air force (hereinafter referred to as pay regulations) and other matters pertaining thereto and in particular governing the following provisions of this Part of this Act.

Forfeitures  
and deduc-  
tions :  
general  
provisions.

152.—(1) No forfeiture of the pay of an officer or airman shall be imposed unless authorized by service law or some other written law and no deduction from such pay shall be made unless so authorized or authorized by pay regulations.

(2) Pay regulations shall not authorize the making of any penal deduction, that is to say, a deduction to be made by reason of the commission of any offence or other wrongful act or in consequence of any negligence.

(3) The foregoing provisions of this section shall not prevent the making of pay regulations providing for the imposition of any forfeiture authorized by this Act or the making of any deduction so authorized, or for the time at which and manner in which sums may be deducted from pay to give effect to authorized deductions or the manner in which amounts may be so deducted in order to recover any fine imposed in pursuance of this Act, or as to the appropriation of any such sum or amount when deducted, or of providing for the determination of questions relating to forfeitures or deductions.

(4) Notwithstanding any deduction from the pay of an officer or airman he shall (subject to any forfeiture) remain in receipt of pay at not less than such minimum rate as may be prescribed in pay regulations.

(5) Notwithstanding that forfeiture of pay of an officer or airman for any period has been ordered in pursuance of this Act, he shall remain in receipt of pay at such a minimum rate as aforesaid, but the amount received for that period may be received from him by deduction from pay.

(6) Any amount authorized to be deducted from the pay of an officer or airman may be deducted from any balance (whether or not representing pay) which may be due to him as an officer or airman and references in this Act to the making of deductions from pay shall be construed accordingly.

Forfeiture  
of pay for  
absence from  
duty.

153.—(1) The pay of an officer or airman may be forfeited—

(a) for any day of absence in such circumstances as to constitute offences of desertion or absence without leave (where such offences are triable by courts martial) or, if the commander so directs, of other absence without leave ;

(b) for any day of imprisonment, detention or field punishment awarded under service law by a court martial or commanding officer, or of imprisonment or detention of any description to which he is liable in consequence of an order or sentence of a civil court ;

(c) where he is found guilty (whether by court martial, an appropriate superior authority or his commanding officer) of an offence under service law, for any day (whether before or after he is found

guilty) on which he is in hospital on account of sickness or injury certified by the proper medical officer to have been occasioned by the offence.

(2) The pay of an officer or airman may be forfeited for any day of absence by reason of his having been made a prisoner of war if the commander is satisfied—

(a) that he was made a prisoner of war through disobedience of orders or wilful neglect of his duty ; or

(b) that having been made a prisoner of war he failed to take any reasonable steps available to him to rejoin the service, or any of the armed forces of Nigeria ;

(c) that having been made a prisoner of war he served with or aided the enemy in the prosecution of hostilities or measures calculated to influence morale or in any other manner whatsoever not authorized by international usage,

but, save as aforesaid, nothing in paragraph (a) of subsection (1) of this section shall apply to absence by reason of having been made a prisoner of war.

(3) Pay regulations may make provision as to the computation of time for the purposes of this section and in particular as to the counting or disregarding of parts of days.

**154.** Where an officer or airman charged with an offence before a civil court (whether within or outside Nigeria) is sentenced or ordered by the court to pay any fine, penalty, damage, compensation or costs, and the whole or part thereof is met by a payment made by or on behalf of any air force authority, the amount of the payment may be deducted from his pay.

Deductions for payment of civil penalties.

**155.—(1)** Without prejudice to the provisions of this Act as to the imposition of stoppages as a punishment, the following provisions shall have effect where, after such investigation as may be prescribed by pay regulations, it appears to the air council, the commander or an officer authorized in pay regulations that any loss of, or damage to, public or service property has been occasioned by any wrongful act or negligence of an officer or airman (hereinafter referred to as "the person responsible").

Compensation for loss occasioned by wrongful act or negligence.

(2) The air council, the commander or officer authorised by pay regulations, as the case may be, may order the person responsible to pay a specified sum as or towards compensation for the loss or damage, and such sum, if not otherwise paid by the person responsible, may be deducted from his pay.

(3) No order shall be made under the provisions of subsection (2) of this section if, in proceedings before a court martial under service law, an appropriate superior authority or a commanding officer, the person responsible—

(a) has been acquitted in circumstances involving a finding that he was not guilty of the wrongful act or negligence in question ; or

(b) has been awarded stoppages in respect of the same loss or damage,

but save as aforesaid, the fact that such proceedings have been brought in respect of the wrongful act or negligence in question shall not preclude the operation of the said subsection (2).

Deductions for barrack damage.

156.—(1) Where damage occurs to any premises in which one or more units or parts of such units are quartered or billeted, or any fixtures, furniture or effects in or belonging to such premises are damaged or lost, and it appears on investigation in accordance with the provisions of pay regulations that the damage or loss was occasioned by the wrongful act or negligence of persons belonging to any of the units or parts of units in occupation of such premises, but that the said persons cannot be identified, any person belonging to any of such units or parts of units may be required to contribute towards compensation for the damage or loss such amount as may in accordance with pay regulations be determined to be just, and the amount may be deducted from his pay.

(2) The provisions of subsection (1) of this section shall extend to ships, trains, motor vehicles and aircraft in which units or parts of units are being transported and reference to premises, quartering and occupation shall be construed accordingly.

Remission of forfeitures and deductions.

157. Any forfeiture or deduction imposed under the authority of this Part of this Act may be remitted by the President or as the case may be, under the authority of pay regulations.

#### PART VII—GENERAL PROVISIONS

##### *Exemptions for Members of Air Force*

Exemptions from tolls, etc.

158.—(1) Duties or tolls for embarking from or disembarking on any pier, wharf, quay or landing place in Nigeria, or for passing over any road, ferry or bridge in Nigeria, shall not be payable in respect of—

(a) members of the air force on duty ;

(b) vehicles in air force service, being vehicles belonging to the Federation or any Region thereof or other vehicles driven by persons (whether a member of the air force or not) in the public service of the Federation or of any Region thereof ;

(c) goods carried in such vehicles ;

(d) horses or other animals in air force service.

(2) For the purposes of this section the expression “in air force service” means employed under proper air force authority for the purposes of any unit or accompanying any body of air force personnel.

Exemption from taking in execution of property used for air force purposes.

159. No judgment, decree or order given or made against a member of the air force by any court in Nigeria shall be enforced by the levying of execution on any property of the member against whom it is given or made, being public property, used by him for air force purposes.

Exemption as to arms and explosives.

160. The officers and airmen who are subject to this Act shall, for purposes of the air force, be exempt from the provisions of any enactment relating to the storage, possession or transmission of firearms, explosives, gunpowder or munitions of war to the same extent as members of any other of the armed forces of Nigeria are so exempt.

*Deserters and Absentees without Leave*

161.—(1) Any police officer may arrest without a warrant a person whom he has reasonable cause to suspect of being an officer or airman who has deserted or is absent without leave; and where no police officer is available, any other person may in like circumstances arrest without a warrant any such person.

Arrest of deserters and absentees without leave.

(2) If any person authorised to issue a warrant for the arrest of a person charged for a criminal offence is satisfied by evidence on oath that there is, or there is reasonably suspected of being, within the jurisdiction an officer or airman who has deserted or is absent without leave, or is reasonably suspected of having deserted or of being absent without leave, he may issue a warrant for the arrest of such person.

(3) Any person in custody under this section shall, as soon as practicable, be brought before a magistrate's court.

(4) Notwithstanding the provisions of any other Act or rule of law, a person appearing before a magistrate's court under this section, shall not be admitted to bail.

162.—(1) Where a person who is brought before a magistrate's court is alleged to be an officer or airman of the air force who has deserted or is absent without leave, the following provisions shall have effect.

Proceedings before a civil court where persons suspected of illegal absence.

(2) If the person so before such court admits that he is illegally absent from the air force and the court is satisfied of the truth of the admission, then unless he is in custody for some other cause the court shall, or notwithstanding that he is in custody for some other cause, the court may, forthwith either cause him to be delivered into air force custody in such manner as the court may think fit or commit him to some prison, police station or other place provided for the confinement of persons in custody, to be kept there for such reasonable time as the court may specify (not exceeding such time as appears to the court reasonably necessary for the purpose of enabling him to be delivered into air force custody) or until sooner delivered into such custody. Any time specified by the court may be extended by the court from time to time if it appears to the court reasonably necessary so to do for the purpose aforesaid.

(3) If such person does not admit that he is illegally absent as aforesaid, or the court is not satisfied of the truth of the admission, the court shall consider the evidence and any statement of the accused. If the court is satisfied that he is subject to air force law under this Act and the court is also of opinion that there is sufficient evidence to justify trial of such person for an offence of desertion or absence without leave then, unless he is in custody for some other cause, the court shall cause him to be delivered into air force custody or commit him as aforesaid, but otherwise shall discharge him:

Provided that if any such person is in custody for any other reason the court may if it thinks fit, and in its discretion act in accordance with this subsection.

(4) If proceedings are taken in a magistrate's court under this section, the law applicable in that court in relation to the constitution and procedure of magistrates courts holding preliminary inquiries and conferring powers of adjournment and remand on such courts so acting, and as to evidence and the issue and enforcement of summonses or warrants to secure the attendance of witnesses, shall apply to such proceedings.

(5) Notwithstanding the provisions of any other Act or rule of law, a person appearing before a magistrate's court under this section, shall not be admitted to bail.

Deserters  
and  
absentees  
without  
leave  
surrendering  
to police.

163.—(1) Where a person elsewhere than at a police station surrenders himself to a police officer as being illegally absent from the air force, the police officer shall forthwith bring him to a police station. The police officer in charge of any such police station shall thereupon enquire into the case, and if it appears that such person is illegally absent from the air force, he may in his discretion, cause such person to be delivered into air force custody without bringing him before a magistrate's court, or may bring him before such court.

(2) Notwithstanding the provisions of any other Act or rule of law, a person appearing before a magistrate's court under this section, shall not be admitted to bail.

Certificates  
of arrest or  
surrender.

164.—(1) Where a magistrate's court under this Part of this Act deals with a person as illegally absent and that person is delivered into air force custody, there shall at the time of such delivery be handed over a certificate in the prescribed form signed by a magistrate, containing particulars as to the arrest or surrender, as the case may be, and of the proceedings before the court.

(2) Where after surrender a person is delivered into air force custody without being brought before a court under the provisions of this or any other Act, there shall be handed over a certificate in the prescribed form signed by the police officer causing the delivery into air force custody, and such certificate shall contain particulars relating to the surrender.

(3) In any proceedings in respect of the offences of desertion or absence without leave (being offences triable at court martial)—

(a) a document purporting to be a certificate under the relative subsection of this section, or under the corresponding provisions of any other Act relating to service law, and to be signed as therein prescribed, shall be evidence of the matters stated in the document ;

(b) where the proceedings are against a person who has been taken into air force custody on arrest or surrender, a certificate in the prescribed form purporting to be signed by a provost officer or any corresponding officer of a force raised under the law of any other country, or by any other officer in charge of the guardroom or other place where that person was confined on being taken into custody, stating the fact, date, time and place of arrest or surrender shall be evidence of the matters stated in the certificate.

Duties of  
superinten-  
dents of  
prisons and  
others to  
receive  
deserters and  
absentees.

165.—(1) It shall be the duty of the superintendent or other person in charge of a civil prison to receive any person duly committed to that prison by a magistrate's court as illegally absent from the air force and to detain him until in accordance with the directions of the court he is delivered into air force custody.

(2) Subsection (1) of this section shall apply to the person having charge of any police station or other place (not being a prison) provided for the confinement of persons in custody as it applies to the superintendent of a prison.

*Offences relating to Air Force Matters Punishable by Civil Courts*

**166.** Any person who falsely represents himself to any air force authority to be a deserter from the air force shall be guilty of an offence and liable on conviction to a fine not exceeding fifty pounds or to imprisonment for a term not exceeding three months, or to both.

Punishment for pretending to be a deserter.

**167.** Any person who—

(a) procures or persuades any officer or airman of the air force to desert or to absent himself without leave ; or

(b) knowing that any such officer or airman is about to desert or absent himself without leave, assists him in so doing, or

(c) knowing any person to be a deserter or absentee without leave from the air force, conceals him or assists him in concealing himself or assists in his rescue from custody,

shall be guilty of an offence and liable on conviction to a fine not exceeding fifty pounds or to imprisonment for a term not exceeding one year, or to both.

Punishment for procuring and assisting desertion.

**168.** Any person who wilfully obstructs or otherwise interferes with any officer or airman of the air force acting in the execution of his duty shall be guilty of an offence and liable on conviction to a fine not exceeding fifty pounds or to imprisonment for a term not exceeding three months, or to both.

Punishment for obstructing members of the air force in execution of duty.

**169.** Any person who—

(a) produces in an officer or airman of the air force any sickness or disability ; or

(b) supplies to or for him any drug or preparation calculated or likely to render him, or lead to the belief that he is permanently or temporarily unfit for service,

with a view to enabling him to avoid air force service, whether permanently or temporarily, shall be guilty of an offence and liable on conviction to a fine not exceeding fifty pounds or to imprisonment for a term not exceeding one year, or to both.

Punishment for aiding malingering.

**170.—(1)** Any person who acquires any air force stores or solicits or procures any person to dispose of any air force stores, or acts for any person in the disposing of any air force stores, shall be guilty of an offence, unless he proves either—

(a) that he did not know, and could not reasonably be expected to know, that the chattels in question were air force stores ; or

(b) that those chattels had (by the transaction with which he is charged or some earlier transaction) been disposed of by order or with the consent of the President or some person or authority who had, or whom he had reasonable cause to believe to have, power to give the order or consent ; or

(c) that those chattels had become the property of an officer who had retired or ceased to be an officer, or of an airman who had been discharged, or of the personal representatives of a person who had died, and shall be liable on conviction to a fine not exceeding five hundred pounds or to imprisonment for a term not exceeding two years, or to both.

Unlawful purchase, etc., of air force stores.

(2) A police officer may arrest without warrant any person whom he has reasonable grounds for suspecting of having committed an offence against this section, and may seize any property which he has reasonable grounds for suspecting of having been the subject of the offence.

(3) Any person authorised to issue a warrant for the arrest of a person charged with crime may, if satisfied by evidence on oath that a person within his jurisdiction has, or is reasonably suspected of having, in his possession any property which has been the subject of an offence against this section, grant a warrant to search for such property as in the case of stolen goods; and any property suspected of having been the subject of such an offence which is found on such a search shall be seized by the officer charged with the execution of the warrant, and that officer shall bring the person in whose possession or keeping the property is found before a magistrate's court. For the purposes of this subsection property shall be deemed to be in the possession of a person if he has it under his control, and whether he has it for his own use or benefit or for the use or benefit of another.

(4) In this section—

“acquire” includes buy, take in exchange, take in pawn or otherwise receive (whether apart from this section the receiving is lawful or not);

“dispose” includes sell, give in exchange, pledge or otherwise hand over (whether apart from this section the handing over is lawful or not);

“air force stores” means chattels of any description belonging to the government of the Federation, issued for use for air force purposes or held in store for the purpose of being so issued when required, or which had so issued or belonged, or been issued or held, at some past time.

Illegal dealings in documents relating to pay, pensions, mobilization, etc.

171.—(1) Any person who—

(a) as a pledge or a security for a debt; or

(b) with a view to obtaining payment from the person entitled thereto of a debt due either to himself or to any other person, receives, detains or has in his possession any official document issued in connection with the payment to any person of any pay, pension, allowance, gratuity or other payment payable in respect of his or any other person's air force service shall be guilty of an offence against this section.

(2) Any person who has in his possession without lawful authority or excuse (the proof whereof shall lie on him) any such document as aforesaid or any official document issued in connection with the mobilization or demobilization of any of the armed forces of Nigeria or any member thereof, shall be guilty of an offence against this section.

(3) Any person guilty of an offence against this section shall be liable on conviction to a fine not exceeding fifty pounds or to imprisonment for a term not exceeding six months, or to both.

(4) For the purposes of this section a document shall be deemed to be in the possession of a person if he has it under his control and whether he has it for his own use or benefit or for the use or benefit of another.

172.—(1) Any person who—

(a) without authority uses or wears any air force decoration or any badge, wound stripe or emblem supplied or authorised by the President or the air council ; or

(b) uses or wears any decoration, badge, wound stripe, or emblem so nearly resembling any air force decoration, or any such badge, stripe or emblem as aforesaid, as to be calculated to deceive ; or

(c) falsely represents himself to be a person who is or has been entitled to use or wear any such decoration, badge, stripe or emblem as is mentioned in paragraph (a) of this subsection,

shall be guilty of an offence against this section :

Provided that nothing in this subsection shall prohibit the use or wearing of ordinary regimental badges or of broaches or ornaments representing them.

(2) Any person who purchases or takes in pawn any air force decoration awarded to any member of the armed forces of Nigeria, or solicits or procures any person to sell or pledge any such decoration, or acts for any person in the sale or pledging thereof, shall be guilty of an offence against this section unless he proves that at the time of the alleged offence the person to whom the decoration was awarded was dead or had ceased to be a member of those forces.

(3) Any person guilty of an offence against this section shall be liable on conviction to a fine not exceeding fifty pounds or to imprisonment for a term not exceeding three months, or to both.

#### *Evidence*

173.—(1) The following provisions shall have effect with respect to evidence in proceedings under this Act, whether before a court martial, a civil court or otherwise.

(2) A document purporting to be a copy of the attestation paper signed by any person and to be certified to be a true copy by a person stated in the certificate to have the custody of the attestation paper shall be evidence of the enlistment of the person attested.

(3) The attestation paper purporting to be signed by a person on his enlistment shall be evidence of his having given the answers to questions which he is therein recorded as having given.

(4) A letter, return or other document stating that any person—

(a) was or was not serving at any specified time or during any specified period in any part of the armed forces of Nigeria or was discharged from any part of those forces at or before any specified time ; or

(b) held or did not hold at any specified time any specified rank or appointment in any of those forces, or had at or before any specified time been attached, posted or transferred to any part of those forces, or at any specified time or during any specified period was or was not serving or held or did not hold any rank or appointment in any particular country or place ; or

Unauthorised use of and dealing in decorations, etc.

Special provisions as to evidence.

(c) was or was not at any specified time authorised to use or wear any decoration, badge, wound stripe or emblem, shall, if purporting to be issued by or on behalf of the commander, be evidence of the matters stated in the document.

(5) A record made in any service book or other document prescribed by regulations under this Act for the purposes of this subsection, being a record made in pursuance of service law or regulation or otherwise in pursuance of air force duty, and purporting to be signed by the commanding officer or by any person whose duty it was to make the record, shall be evidence of the facts stated therein and a copy of a record (including the signature thereto) in one of the said service books and a copy of such document, purporting to be certified to be a true copy by a person stated in the certificate to have the custody of the book or the original document, as the case may be, shall be evidence of the record.

(6) A document purporting to be issued by the order of the air council or the commander and to contain instructions or orders given or made by the air council or the commander shall be evidence of the giving of the instructions, or making of the orders and of their contents.

(7) A certificate purporting to be issued by or on behalf of the air council or the commander and stating—

(a) that a decoration of a description specified in or annexed to the certificate is an air force decoration ; or

(b) that the badge, wound stripe or emblem of a description specified in or annexed to the certificate is one supplied or authorised by the President or the air council,

shall be evidence of the matters stated in the certificate.

(8) A certificate purporting to be signed by a person's commanding officer or any officer authorized by him to give the certificate, and stating the contents of, or any part of, standing orders or other routine orders of a continuing nature made for—

(a) any formation, unit or body of air force personnel ; or

(b) any area, garrison or place ; or

(c) any ship, train or aircraft,

shall in proceedings against the said person be evidence of the matters stated in the certificate.

*Proof of  
outcome of  
civil trial.*

174.—(1) Where a person subject to air force law under this Act has been tried before a civil court (whether at the time of the trial he was so subject or not), a certificate signed by a judge or a magistrate and stating all or any of the following matters—

(a) that the said person has been tried before the court for an offence specified in the certificate ;

(b) the result of the trial ;

(c) what judgment or order was given or made by the court ;

(d) that other offences specified in the certificate were taken into consideration at the trial ;

shall for the purposes of this Act be evidence of the matters stated in the certificate.

(2) A document purporting to be a certificate under this section and to be signed by a judge or a magistrate shall, unless the contrary is shown, be deemed to be such a certificate.

175.—(1) The original proceedings of a court martial under service law purporting to be signed by the president of the court and being in the custody of the commander or of any person having the lawful custody thereof shall be admissible in evidence on production from that custody.

Evidence of proceedings of court martial

(2) A document purporting to be a copy of the original proceedings of a court martial under service law or any part thereof and to be certified by the commander or any person authorized by him, or by any other person having the lawful custody of the proceedings, to be a true copy shall be evidence of the contents of the proceedings or the part to which the document relates, as the case may be.

(3) This section applies to evidence given in any court, whether civil or criminal.

#### *Reductions in Rank*

176.—(1) A warrant officer shall not be reduced in rank except by sentence of a court martial under service law or by order of the commander.

Restrictions on reduction in rank of warrant officers and non-commissioned officers.

(2) A non-commissioned officer shall not be reduced in rank except by—

(a) by sentence of a court martial under service law ; or

(b) in the case of a non-commissioned officer other than a leading aircraftman, by award or order of the commander or of an officer by whom the commander's powers of reduction are exercisable by virtue of this Act ; or

(c) in the case of a leading aircraftman, by award or order of his commanding officer.

(3) Where it appears to the commander that a warrant officer or non-commissioned officer (other than a leading aircraftman) is unable to perform satisfactorily the functions of his rank, the commander may by order reduce the warrant officer or non-commissioned officer to such rank or to the ranks as he may specify in the order ; and where it appears to a commanding officer that a leading aircraftman serving under his command is unable to perform satisfactorily the functions of his rank, the commanding officer may by order reduce the leading aircraftman to the ranks.

(4) The commander may by order direct that the powers conferred upon him by this Act to reduce corporals in rank or to the ranks may be exercised in respect of such non-commissioned officers by officers not below the rank of air commodore under whose command the corporals may be serving.

(5) Nothing in this section shall apply to any acting rank, and the holders thereof may be reduced accordingly to their substantive ranks as occasion may require.

*Miscellaneous*

Temporary reception into civil custody of persons under escort.

177.—(1) Where a person is in air force custody when charged with, or with a view to his being charged with, an offence against Part IV or the corresponding provisions of any other service law, it shall be the duty of the superintendent or other person in charge of a civil prison, or of the person having charge of any police station or other place in which prisoners may be lawfully detained, upon delivery to him of a written order purporting to be signed by the commanding officer of the person in custody to receive him into his custody for a period not exceeding seven days.

(2) In this section "civil prison" has the meaning ascribed to it in section one hundred and thirty-one of this Act.

Avoidance of assignment of, or charge on, air force pay, pensions, etc.

178.—(1) Every assignment of or charge on, and every agreement to assign or charge, any pay, air force award, grant, pension or allowance payable to any person in respect of his or any other person's service in the armed forces of Nigeria shall be void.

(2) Save as expressly provided by this Act, no order shall be made by any court the effect of which would be to restrain any person from receiving anything which by virtue of this section he is precluded from assigning and to direct payment thereof to another person.

(3) Nothing in this section shall prejudice any enactment providing for the payment of any sum to a bankrupt's trustee in bankruptcy for distribution among creditors.

Power of certain officers to take statutory declarations.

179.—(1) Notwithstanding the provisions of any other Act, an officer of a rank not below that of squadron leader may, outside Nigeria, take statutory declarations from persons subject to this Act, and for the purposes of this Act.

(2) Where a document purporting to be a statutory declaration is signed by the declarant in the presence of an officer not below the rank of squadron leader, and that officer has set out therein his full name and rank together with a statement of the date and place where the declaration was made, such document shall be received by all courts and persons as sufficient evidence of entitlement without proof of the signature of the officer before whom the declaration was made, or of the facts set out therein by him.

## PART VIII.—AIR FORCE RESERVE

Reservists.

180. This Part of this Act shall apply to all persons (in this Part referred to as "reservists") who, as members of the air force reserve, are liable to be called out for training or service, as the case may be, and notwithstanding the provisions of any other Part of this Act.

Annual training.

181.—(1) Every reservist shall be liable to be called out for training at such place and for such periods not exceeding twenty-eight days in any one year as may be prescribed by regulations made under this Part of this Act.

(2) Every reservist may, during any training for which he may be called out, be attached to and trained with any unit.

182.—(1) The President, as and when occasion may so require, may call out the air force reserve, or as many reservists as he thinks necessary, to aid the civil power in the preservation of the public peace.

Calling out of the reserve to aid the civil power.

(2) Reservists called out for service under this section shall not be liable to serve at any one time for a period exceeding twenty-eight days.

183.—(1) Where there is a state of war or any insurrection, hostilities or public emergency, it shall be lawful for the President by proclamation, to call out the air force reserve on permanent service.

Calling out of the reserve on permanent service.

(2) The President may by the same or any other proclamation, give or authorise the Minister to give such directions as may seem necessary or proper for calling out the air force reserve or any reservist.

(3) Every reservist so called out shall comply with the directions given as if they were orders of a superior officer and shall attend at the place and time prescribed; and any such reservist shall thereupon be deemed to be called out on permanent service.

(4) Every reservist called out on permanent service shall be liable to serve as an airman of the air force until his services are no longer required, so, however, he shall not be required to serve for a period exceeding in the whole the remaining unexpired term of service in the reserve and any further period not exceeding twelve months as an airman may, under this Act, be retained on permanent service in the air force after the time at which he would otherwise be entitled to be discharged.

184.—(1) Any reservist who, without leave lawfully granted or other reasonable excuse, fails to appear at the time and place appointed for annual training, or when called out to aid the civil power or on permanent service, shall—

Punishment for non-attendance.

(a) if called out on permanent service, be guilty, according to the circumstances, of desertion or of absenting himself without leave; or

(b) if called out to aid the civil power or for annual training, be guilty of absenting himself without leave.

(2) Any reservist who commits any offence under this section may be tried—

(a) by court martial, and on conviction, shall be liable to imprisonment for a term not exceeding two years or such less punishment as is provided by this Act; or

(b) by a magistrate's court and, on conviction, shall be liable to a fine not exceeding fifty pounds, or to imprisonment for a term not exceeding two years.

(3) The provisions of section seventy-eight and of sections one hundred and sixty-one to one hundred and sixty-five of this Act (which relate to offences by air force personnel) shall apply to reservists who commit or are alleged to have committed or are reasonably suspected of having committed an offence against this section as they apply to persons otherwise subject to air force law under this Act.

185. Where a reservist fails to appear at the time and place appointed for annual training or when called out to aid the civil power or on permanent service, and his absence continues for not less than

Record of illegal absence.

twenty-one clear days, an entry of such absence shall be made by an officer in the service books prescribed for use under this Part of this Act, and where an entry is so made it shall be *prima facie* evidence of the fact of such absence.

Discharge during service.

186. A reservist may be discharged by a competent air force authority at any time during the currency of any term of service in the air force reserve.

Regulations as to the reserve.

187. The President may make regulations under this Part of this Act with respect to the government and discipline of the air force reserve, and, without prejudice to the generality of the foregoing, regulations may provide—

(a) for the calling out for training of reservists ;

(b) for the calling out of the air force reserve to aid the civil power and on permanent service ;

(c) for providing for the pay of reservists, whether on the reserve or called out under this Part of this Act ;

(d) for requiring reservists to report themselves from time to time, and to obtain the permission of a competent air force authority before leaving Nigeria ; and

(e) for any other matter or thing which is required by this Part of this Act to be prescribed.

#### PART IX.—APPLICATION OF THE ACT AND SUPPLEMENTARY PROVISIONS

##### *Application*

Application of the Act.

188.—(1) The following persons shall be subject to air force law under this Act—

(a) officers and airmen of the air force ;

(b) officers of the reserve when called out on service ; and

(c) reservists called out for training, to aid the civil power or on permanent service.

(2) This Act shall apply to the persons subject thereto under the provisions of this section, and in relation to the units raised in Nigeria or elsewhere as part of the air force.

Application of the Act to women.

189.—(1) The provisions of this or any other Act in so far as they contain or refer to the word "airman" or other word importing reference to persons of the male sex only as, or as having been, members of the air force and accordingly subject to air force law under this Act, shall have effect as if for any such word there had been substituted therein words having a like meaning in other respects but importing a reference to persons of either sex.

(2) In relation to women members of the air force, this Act shall have effect subject to the following modifications—

(a) so much of Parts I, II, III and VIII as relate to service in, and transfer to, the air force reserve shall not apply

(b) so much of Part IV as provides for field punishment shall not apply ;

(c) References in sections one hundred and ninety-four and one hundred and ninety-six of this Act to a widow shall, for the avoidance of doubt, be construed as references to a widower, and the Interpretation Act, 1964 shall have effect accordingly.

1964, No. 1.

190.—(1) Subject to the modifications in the next succeeding subsection, where any unit is on active service and a person is employed in the service of that unit or any part thereof or accompanies such unit or part thereof and is not otherwise subject to service law, the person so employed or accompanying the unit shall be subject to air force law under this Act, and Part IV of this Act shall apply to any such person as it applies to members of the air force.

Application of the Act to civilians.

(2) The said modifications are the following—

(a) the punishments which may be awarded by a court martial shall include a fine, but shall not include any other punishment less than imprisonment ;

(b) where a charge is dealt with summarily, the punishment awarded shall in no case exceed ten pounds in respect of any one offence ;

(c) subsections (2) to (4) of section seventy-eight of this Act (which relates to the power to arrest certain offenders) shall not apply, and the person so employed may be arrested by a provost officer, or by any warrant officer or non-commissioned officer legally exercising authority under a provost officer or on his behalf, or by order of any such officer ;

(d) the provisions of this Act relating to the investigation of, and summary dealing with, offences shall, save as otherwise expressly provided apply to persons so employed as they apply to airmen ;

(e) for the purposes of this Act in its application to the investigation of offences, the commanding officer shall be such officer as may be appointed by an officer authorised to convene a court martial ;

(f) references in sections one hundred and seventeen and one hundred and eighteen of this Act to being, continuing, or ceasing to be subject to air force law shall be omitted, and there shall be substituted references to being, continuing to be, or ceasing to be so subject in such circumstances that Part IV of this Act applies (other than in the reference in section one hundred and seventeen to the holding or air force rank in any trial and punishment of offences).

(3) Any fine awarded by virtue of this section, whether by a court martial or a commanding officer, shall be recoverable as a debt due to the Government of the Federation.

191.—(1) The provisions of Part IV of this Act with all necessary modifications and subject to the provisions of this section, shall apply to passengers on board any aircraft of the air force.

Application of the Act to passengers.

(2) For the purposes of this section, "passengers" does not include personnel of the army, navy or air force who under this or any Act are otherwise subject to discipline as members of the armed forces of Nigeria.

*Wills and Distribution of Property*

Airman on enlistment to register the name of person entitled on his intestacy, etc.

192.—(1) Every airman on enlistment shall—

(a) declare the name of the person or persons to whom, in the event of his dying without having made a valid will, any money or personal property due or belonging to him should be paid or delivered or

(b) declare that his estate is to be administered by a customary court (by whatever name called) of some named place according to the customs of his tribe;

and the name of such person or customary court shall be recorded on his attestation paper. The record shall be verified periodically, and it shall be the duty of the airman to report any alteration in the record which he wishes made.

(2) Any officer of the air force, the Accountant-General or any public department, having in his or its charge or control any pay, accumulations of pay, gratuity or other allowance, or any personal property or money belonging to any airman dying intestate who has complied with the above conditions, may pay or deliver the same to the person whose name has been recorded, or to a customary court of the place named, by the airman in the manner prescribed.

Special provisions relating to airman's wills.

193.—(1) Any will made by an airman shall be valid for disposing of any money or personal property which is due or belonging to him at his decease if it is in writing and signed or acknowledged by him in the presence of, and in his presence attested by one witness, being an officer of the air force or any government medical officer. The will shall be deemed well made for the purpose of being admitted to probate, and the person taking out representation to the testator under such will shall exclusively be deemed the testator's representative with respect to the money or personal property thereby bequeathed.

(2) Any officer of the air force, the Accountant-General, or any public department, having in his or its charge or control any pay, accumulation of pay, gratuity or other allowance, or any personal property or money belonging to such testator, not exceeding in the aggregate the value of one hundred pounds, may pay or deliver the same to any person entitled thereto under the will, or to the person entitled to procure probate of or administration under such will, although probate or administration may not have been taken out.

(3) If the value of the money and personal property exceeds one hundred pounds, the paymaster or other officer, or public department having charge or control thereof shall require probate, or administration to be taken out and thereupon pay or deliver the said money and effects to the legal representative of the deceased.

Distribution in case of deceased airman's intestacy.

194.—(1) If any airman dies without having complied with the requirements of this Part of this Act as to the disclosure of next of kin, or has not made a will valid under this or any other enactment relating to wills and for the time being in force, any officer of the air force or the Accountant-General or any public department having in his or its charge or control money or personal property of the deceased may, with the concurrence of the commander or any officer acting on behalf of the commander, pay or deliver such money or personal property to

any claimant who proves to the satisfaction of the commander or such officer, relationship as the widow of the deceased or the child or other near relative of the deceased, as the case may be, according to the rules of succession of the tribe to which the deceased belonged. If there are more of such claimants than one, payment or delivery may be made in such shares and proportions as the claimants would be entitled to receive under the rules of succession prevailing among such tribe, or as nearly as may be.

(2) Where the airman was a moslem, the distribution of the estate may be carried out by the Alkali's court of the district from which the airman came, and the alkali shall be responsible to the regional Administrator-General for the carrying out of the distribution in accordance with Islamic law. If there is no such court in the district, the distribution may be made as nearly as may be in accordance with such law.

195.—(1) Where probate of the will or administration with or without the will annexed of the estate of a deceased airman is not taken out, and an officer of the air force, the Accountant-General or officer of any public department before disposing of the money and personal property of the deceased has notice of any debt due by the deceased, he shall, anything to the contrary in this Part of this Act notwithstanding, apply such money and property as may remain in his authority or control, or so much thereof as may be requisite in or towards the payment of such debt, if he is satisfied—

Payment of  
debts of  
deceased  
airman.

(a) that the claimant has proved the debt to the satisfaction of the commander or of the officer acting on behalf of the commander ; and

(b) that demand for payment of the debt is made within one year after such death ; and

(c) that the debt was incurred within three years before the death of the airman.

(2) A person claiming to be a creditor of a deceased airman shall not be entitled to obtain payment of his debt out of money in the hands of any officer of the air force, the Accountant-General or any public department, except by means of a claim on any officer responsible for an airman's pay, and proceeding thereon under and in accordance with this Act. If the estate is being administered by a customary court, any government debt shall be paid by the officer concerned before the balance of the estate is passed to the customary court, and that court shall thereafter be responsible to see that all other debts are settled before final distribution of the estate of the deceased airman under this section.

196. Where money or personal property of a deceased airman or any part thereof is paid or delivered to any person recorded as next of kin under this Part of this Act or as beneficiary under the will of the deceased, or as his widow or child, or otherwise in accordance with this Act as a near relative, any creditor of the deceased shall have the same rights and remedies against the person to whom the money or personal property is paid or delivered as if such person had received the money or personal property as legal personal representative of the deceased.

Property of  
deceased air-  
man  
distributed  
subject to  
rights of  
creditors.

Deceased airman's money undisposed of applied to prescribed fund.

197.—(1) Subject to the provisions of this section, if money or personal property belonging to a deceased airman, or any part thereof, remains for one year undisposed of or unappropriated, and without any valid claim thereto having been made, it shall after conversion into cash where necessary, be paid over to the Accountant-General and be applied towards forming a fund for the benefit of airmen and ex-airmen of the air force who are in distress, or for the benefit of the air force generally, or for charitable purposes.

(2) The application under the foregoing subsection of any such money or property or part thereof towards such fund shall not be a bar to any subsequent claim by any person, established within twelve months after such application.

(3) The Minister after consultation with the air council may make regulations for the formation of the fund and any disbursements may be made out of such fund in accordance with the regulations. The regulations may provide for the fund to be identical with the Nigerian Air Force Benefit Fund under this Act or for the fund to be a separate fund administered for the purposes of this section.

Uniforms and decorations of deceased airman.

198. The claims of creditors shall not extend to uniforms and decorations of a deceased airman, and accordingly nothing in this Act shall prohibit the delivery to and disposal of any such uniform or decoration by the officer concerned under the provisions of this Part of this Act.

Application of money, etc., in case of desertion.

199. Money or other property of a deserter under this Act in the charge or control of an officer of the air force, the Accountant-General or any public department shall be disposed of as nearly as may be in accordance with the provisions of section one hundred and ninety-five of this Act or as may otherwise be prescribed under this Act, and if that section is invoked it shall have effect accordingly.

#### Miscellaneous

Power to make regulations generally.

200. The President may in any case not otherwise provided for under this Act make regulations generally of prescribing or providing for an act, matter or thing.

Powers exercisable in subsidiary legislation.

201.—(1) Any power conferred by this Act to make regulations, rules, orders or other instruments shall include power to make provision for specified cases or classes of cases, and to make different provisions for different classes of cases, and for the purposes of any such instrument, classes of cases may be defined by reference to any circumstances specified in the instrument.

(2) Any such regulations, rules, orders, or other instruments may impose conditions, require acts or things to be performed or done to the satisfaction of any person named therein whether or not such persons are members of the air force or of other of the armed forces of Nigeria, empower such persons to issue orders either orally or in writing requiring acts or things to be performed or done or prohibiting acts or things from being performed or done, and prescribe periods or dates upon, within or before which such acts or things shall be performed or done, or such conditions shall be fulfilled, and provide for appeal against any such order, requirement or direction.

202.—(1) In this Act the expression "on active service" means in relation to any unit, that it is engaged in operations against an enemy, and in relation to a person, that the person is serving in or with a unit which is on active service.

Provisions  
as to active  
service.

(2) Where it appears to the President that, by reason of the imminence of active service or of the recent existence of active service, it is necessary for the service of the public that a unit should be deemed to be or continue to be on active service he may declare that for such period, not exceeding three months, beginning with the coming into force of the declaration as may be specified therein, that unit shall be deemed to be on active service.

(3) Where it appears to the President that it is necessary for the service of the public that the period specified in a declaration under subsection (2) of this section should be prolonged or, if previously prolonged under this subsection should be further prolonged, he may declare that the said period shall be prolonged by such time, not exceeding three months, as may be specified in the declaration under this subsection.

(4) If at any time while any unit is deemed to be on active service by virtue of the foregoing provisions of this section, it appears to the President that there is no necessity for the unit to continue to be treated as being on active service, he may declare that as from the coming into operation of the declaration the unit shall cease to be, or to be deemed to be, on active service.

203. Any order or determination by an air force officer or air force authority may, unless otherwise prescribed by rules or regulations made under this Act, be signified under the hand of any officer authorised in that behalf; and any instrument signifying such an order or determination and purporting to be signed by an officer stated therein to be so authorised shall, unless the contrary is proved, be accepted by all courts and persons as sufficient evidence accordingly.

Execution  
of orders,  
instruments,  
etc.

204.—(1) All fines awarded under Part IV of this Act shall be paid over to the Accountant-General and be applied towards forming a fund to be known as the Nigerian Air Force Benefit Fund for the purpose of making money available to the benefit of airmen and ex-airmen of the air force who are in distress, or for the benefit of the air force generally, or for charitable purposes.

Nigerian Air  
Force  
Benefit  
Fund.

(2) The Minister, after consultation with the air council may make regulations for the formation of such benefit fund, and any disbursements may be made out of such fund in accordance with the regulations.

205. Officers of the air force shall have and enjoy the like powers, rights, immunities and privileges as are by any means conferred upon and enjoyed by commissioned officers of any other of the armed forces of Nigeria.

Rights of  
officers.

206.—(1) The President may by order apply with all necessary modifications and adaptations, in relation to the air council, the chairman of the air council and to the air force (as well officers and airmen as property and institutions) any of the enactments relating to the Army Council, the Minister of Defence and to the Army (as well officers and other ranks as military property and institutions).

Application  
of other  
Acts.

(2) Where any enactment is to be applied under the foregoing subsection, the expression "enactment" shall include any enactment conferring powers, rights, exemptions or abatements from taxation or immunities, or imposing duties or disabilities on such officers or airmen, or other ranks, as the case may be.

Consequen-  
tial amend-  
ments.

207.—(1) The Air Force Act, 1955, of the United Kingdom and its amendments and any transitional provisions affecting or relating to any expired Air Force Act of the United Kingdom, to the extent to which they or any of them may apply or may have applied to Nigeria shall, on the coming into operation of this Act, cease to have effect in Nigeria.

Second  
Schedule.

(2) The Acts set out in the Second Schedule to this Act are hereby amended to the extent therein set forth (being amendments consequential on the establishment of an air force for Nigeria).

Interpreta-  
tion.

208.—(1) In this Act, unless the context otherwise requires—

"Accountant-General" means the Accountant-General of the Federation ;

"the air council" means the air council established under this Act ;

"the air force" means the Nigerian Air Force ;

"air signal" means any message, signal or indication given, by any means whatsoever, for the guidance of aircraft or a particular aircraft ;

"airman" does not include an officer but, with the modifications contained in this Act in relation to warrant officers and non-commissioned officers, includes a warrant officer and a non-commissioned officer and every person subject to air force law under this Act during the time that he is so subject ;

"acting rank" means rank of any description in the air force and however called so that a commanding officer may with or without preferring a charge under this Act order the holder to revert to a lower rank or to his substantive rank as the case may be, and references to "acting warrant officer" and "acting non-commissioned officer" shall be construed accordingly ;

"aircraft material" includes—

(a) parts of, and components of or accessories for, aircraft, whether for the time being in aircraft or not ;

(b) engines, armaments, ammunition and bombs and other missiles of any description in, or for use in, aircraft ;

(c) any other gear, apparatus or instruments in, or for use in, aircraft ;

(d) any apparatus used in connection with the taking-off or landing of aircraft or for detecting the movement of aircraft ; and

(e) any fuel used for the propulsion of aircraft and any material used as a lubricant for aircraft or aircraft material ;

"allied forces" means any military, naval or air force of a country allied or associated with Nigeria and includes any Commonwealth force ;

"arrest" includes open arrest ;

"boy" means any member of the air force who has not attained the age of eighteen years ;

"civil court" means a court of competent criminal jurisdiction but does not include any customary court by whatever name called ;

"the commander" means the officer appointed by the President to command the air force and the air force reserve under this Act ;

"commanding officer" in relation to any person means the officer commanding the unit to which the person belongs or is attached ;

"corresponding rank" in relation to any rank of any other of the Nigerian forces or an allied force means such rank in that force as may be declared under this Act to correspond with a rank under this Act ;

"court martial" save where expressed to be under service law, means a court martial under this Act ;

"customary court" includes an Alkalis' court, and any other court at any time before or after the coming into operation of this Act, known as a native court ;

"damage" and cognate expressions include destruction ;

"date of attestation" in relation to any person means the date on which he is attested as having enlisted in the air force ;

"decoration" includes any medal, medal ribbon, clasp and good conduct badge ;

"enemy" means persons engaged in armed operation against Nigeria, and includes armed mutineers, armed rebels, armed rioters and pirates ;

"imprisonment rules" means rules regulating imprisonment made by the President under this Act ;

"Minister" means the Minister charged with the responsibility for matters relating to defence ;

"mutiny" means a combination between two or more persons subject to service law, or between persons two at least of whom are subject to service law—

(a) to overthrow or resist lawful authority in any of the armed forces of Nigeria or any forces co-operating therewith or in any part of any of the said forces, or

(b) to disobey such authority in such circumstances as to make the disobedience subversive of discipline, or with the object of avoiding any duty or service against, or in connection with operations against the enemy, or

(c) to impede the performance of any duty or service in any of the armed forces of Nigeria or in any forces co-operating therewith or in any part of any of those forces ;

"provost officer" means a provost marshal or officer appointed to exercise the functions conferred by or under service law on provost officers ;

"regular service" means service in the air force under this Act other than service in the air force reserve ;

"service law" means this Act and any Act relating to the army or navy of Nigeria, and includes as occasion may require, the military, naval or air force law of any allied force ;

"ship" includes any description of vessel ;

Cap. 42

"steals" has the meaning for the time being assigned to it in the Criminal Code ;

"stoppages" means in relation to pay, the recovery of deduction from the pay of the offender of a specified sum by way of compensation for any expense, loss or damage occasioned by the offence ;

"unit" means a flight, squadron, wing, group or other formation of the air force presently declared to be a unit by the air council.

(2) Any person who—

(a) leaves any of the armed forces of Nigeria or, when it is his duty to do so, fails to join or rejoin any of those forces with (in either case) the intention, subsisting at the time of the leaving or failure or formed thereafter, of remaining permanently absent from his duty ; or

(b) being an officer, enlists in or enters any other of the armed forces of Nigeria without having resigned his commission, or being an airman enlists or enters in any other of the armed forces of Nigeria without having been discharged from his previous enlistment ; or

(c) absents himself without leave with intent to avoid serving at any place out of Nigeria or to avoid service or any particular service when before the enemy,

shall be a deserter under this Act and references to desertion shall be construed accordingly.

(3) Where by this Act it is provided that any person subject to air force law under this Act shall be liable on conviction by court martial to imprisonment, and no term or maximum term is specified the person so convicted shall be liable to imprisonment for any term.

Short title,  
commence-  
ment and  
application.

209.—(1) This Act may be cited as the Air Force Act, 1964, and shall come into operation on a date to be appointed by the Minister by order in the Gazette.

(2) This Act shall have effect throughout the Federation.

## SCHEDULES

## FIRST SCHEDULE

Section 97

*Alternative offences of which accused may be convicted  
by court martial**Offence charged**Alternative offences*

- |  |   |
|--|---|
| 1. Any offence against subsection (1) of section 32.   | 1. Any offence against subsection (2) of section 32.  |
| 2. Any offence against subsection (1) of section 33.   | 2. Any offence against subsection (2) of section 33.  |
| 3. Communicating with or giving intelligence to the enemy either with intent to assist the enemy or without authority.     | 3. Disclosing information without authority.  |
| 4. Any offence against subsection (1) of section 39.   | 4. Any offence against subsection (2) of section 39.  |
| 5. Striking his superior officer.  | 5. (a) Using violence to his superior officer otherwise than by striking him.<br>(b) Offering violence to his superior officer.                           |
| 6. Using violence to his superior officer otherwise than by striking him.  | 6. Offering violence to his superior officer.   |
| 7. Using threatening language to his superior officer.   | 7. Using insubordinate language to his superior officer.  |
| 8. Disobeying, in such a manner as to show wilful defiance of authority, a lawful command given or sent to him personally. | 8. Disobeying a lawful command.   |
| 9. Desertion.  | 9. Absence without leave.   |
| 10. Attempting to desert.  | 10. Absence without leave.  |
| 11. Stealing any property.   | 11. Fraudulently misapplying the property.  |
| 12. Any offence against any section involving wilfulness.  | 12. The corresponding offence involving negligence.   |
| 13. Any offence against subsection (1) of section 59.  | 13. Any offence against subsection (2) of section 59.   |
| 14. Any offence against section 60 involving striking.   | 14. (a) The corresponding offence involving the use of violence other than striking.<br>(b) The corresponding offence involving the offering of violence. |
| 15. Any offence against section 60 involving the use of violence other than striking.                                      | 15. The corresponding offence involving the offering of violence.   |

## SECOND SCHEDULE

## Section 207

## Consequential Amendments

Number	Short Title	Extent of Amendment
No. 26 of 1960	The Royal Nigerian Army Act 1960	In section two in subsection (1) by repealing in the definition of "service law" the figures "1955" and substituting the figures "1964".  In section one hundred and fifty-nine in subsection (1) by deleting the word "military".
1960 No. 9	The Royal Nigerian Navy Act 1960	In section thirty-nine in subsection (1) by substituting the word "armed" for the word "military"; and in subsection (2) by substituting the word "armed" for the word "military" where it first occurs.  In section forty in subsection (1) by repealing the words "under the Royal Nigerian Army Act 1960" (as substituted by the Act of that title) and substituting the words "or to air force law".  In section forty-two in subsection (1) by repealing the words "the military" and substituting the words "any other of the armed".  In the First Schedule in Part II in paragraph (2) by repealing in sub-paragraph (viii) the words "Royal Nigerian Army" (as substituted by the Royal Nigerian Army Act 1960) and substituting the words "army and air force of Nigeria".

# LAGOS TOWN PLANNING (COMPENSATION) ACT, 1964



1964, No. I

AN ACT TO PROVIDE FOR THE WITHHOLDING OF COMPENSATION PAYABLE UNDER THE LAGOS TOWN PLANNING ACT IN RESPECT OF CERTAIN ESTATES AND INTERESTS IN LAND ; AND FOR PURPOSES CONNECTED WITH THE MATTER AFORESAID.

[See section 2(2)]

Commence-  
ment.

BE IT ENACTED by the Legislature of the Federation of Nigeria in this present Parliament assembled and by the authority of the same as follows :

1.—(1) Where—

(a) any land vests in the Lagos Executive Development Board by virtue of section forty-five of the Lagos Town Planning Act in pursuance of provisions in that behalf contained in a scheme (within the meaning of that Act) either as originally made or as subsequently amended ; and

(b) apart from this subsection an estate or interest in the land created on or after the date when the scheme or, as the case may be, the amending scheme was made would fall to be taken into account in determining the compensation payable in respect of the acquisition of the land by the Board,

then, unless the President otherwise directs in writing, no account shall be taken of that estate or interest in determining the amount of, and the persons entitled to receive, any such compensation as aforesaid.

(2) The foregoing subsection shall be deemed to have come into operation on the first day of January, nineteen hundred and fifty-one ; but where the Board has, before the first day of January, nineteen hundred and sixty-four, paid any sum by way of the whole or part of the compensation payable by the Board apart from the foregoing subsection in respect of any land, nothing in that subsection shall—

(a) entitle the Board to recover that sum ; or

(b) entitle any person to claim any payment from the Board or any other person in respect of that land.

Withholding  
of compen-  
sation in  
certain cases  
Cap. 95.

(3) In relation to a scheme in respect of which a notice is published after the passing of this Act in pursuance of subsection (3) of section twenty-one of the Lagos Town Planning Act (which provides that upon the framing of a scheme particulars of it shall be published in the Gazette) paragraph (b) of subsection (1) of this section shall have effect as if for the reference to the date of the making of the scheme or amending scheme there were substituted a reference to the date of the beginning of the period of twelve months ending with the date of first publication of the notice aforesaid.

(4) The foregoing provisions of this section shall have effect notwithstanding anything in section thirty-one of the Constitution of the Federation (which relates to the compulsory acquisition of property).

Short title,  
extent and  
commence-  
ment.

2.—(1) This Act may be cited as the Lagos Town Planning (Compensation) Act, 1964, and shall apply to the Federal territory only.

(2) This Act shall come into force on such date as the President may by order appoint.

## THE NIGERIAN LEGION BILL

## ARRANGEMENT OF CLAUSES

<p><i>Clause</i></p> <p>1. Establishment and functions of Nigerian Legion.</p> <p>2. Management of affairs of Legion.</p> <p>3. Membership of the Legion.</p> <p>4. Financial provisions.</p> <p>5. Annual report.</p> <p>6. Winding-up of N.E.W.A.</p>	<p>7. Interpretation.</p> <p>8. Short title, extent and commencement.</p> <p>SCHEDULES :</p> <p>First Schedule—Constitutions etc. of councils.</p> <p>Second Schedule—Enactments repealed.</p>
---	--

## A BILL

## FOR

AN ACT TO MAKE FRESH PROVISION WITH RESPECT TO THE WELFARE OF EX-SERVICEMEN ; AND FOR PURPOSES CONNECTED THEREWITH.

[See section 8 (2)]

Commence-  
ment.

BE IT ENACTED by the Legislature of the Federation of Nigeria in this present Parliament assembled and by the authority of the same as follows :—

1.—(1) There shall be established, as the successor of the Nigerian Ex-Servicemen's Welfare Association, an association to be known as the Nigerian Legion, which shall be a body corporate by the name aforesaid and of which every ex-serviceman shall be entitled to be a member.

Establish-  
ment  
and  
functions of  
Nigerian  
Legion.

(2) The Legion shall be charged with the general function of promoting the welfare of ex-servicemen and comradeship among ex-servicemen.

(3) For the purpose of performing the general function aforesaid it shall in particular be the duty of the Legion to take such steps as it considers to be appropriate and within its resources with a view to—

- (a) raising money for the purposes of the Legion ;
- 15 (b) affording help, either by way of grants of money or otherwise, to ex-servicemen appearing to the Legion to be in need of assistance ;
- (c) establishing and maintaining hostels for ex-servicemen appearing to the Legion to be incapacitated by old age or illness ; and
- 20 (d) providing centres at which advice on matters affecting their interests may be obtained by ex-servicemen.

References in this subsection to ex-servicemen include references to members of the families of ex-servicemen and of deceased ex-servicemen.

(4) The Legion shall have power to do such things as it considers expedient for the purpose of performing its functions, so however that the Legion shall not, without the previous consent in writing of the Minister,—

- (a) dispose of or charge any land held for the purposes of the Legion, or any interest in land so held ; or
- (b) borrow money ; or
- 30 (c) enter into a contract to employ any person.

Management of affairs of Legion.

(5) The Minister may from time to time give to the Legion directions in writing with respect to the performance of its functions ; and it shall be the duty of the Legion to comply with the directions.

2.—(1) There shall be established for the purposes of the Legion a national council as respects the Federation and local councils as respects each territory within the meaning of the Constitution of the Federation ; and the provisions of the First Schedule to this Act shall have effect with respect to the constitutions of those councils and the other matters there mentioned. 5

(2) Subject to the provisions of subsections (3) to (6) of this section, the affairs of the Legion shall be managed by the national council, and references to the Legion in this Act shall be construed accordingly ; and without prejudice to the generality of the foregoing provisions of this subsection— 10

(a) any thing falling to be done by or to the Legion shall be done by or to the national council on behalf of the Legion, or by or to such person acting as the representative of the national council as that council may determine ; and 15

(b) in particular, any contract or instrument which, if made or executed by a person not being a body corporate, would not be required to be under seal may be made or executed on behalf of the Legion by any person generally or specially authorised to act for that purpose by the national council. 20

(3) Subject to any directions given by the Minister in pursuance of this Act, the national council may charge a regional council established by this Act or the Lagos council with the performance, in accordance with such conditions as the national council may specify, of any of the functions of the national council falling to be performed within the territory in question. 25

(4) Subject to any such directions as aforesaid, a regional council may charge the council of any area into which the relevant Region is divided in pursuance of the First Schedule to this Act with the performance, in accordance with such conditions as the regional council may specify, of any of the functions of the regional council falling to be performed within the area in question. 30 35

(5) Subject to any such directions as aforesaid, the Lagos council and an area council established by this Act may charge the council of any sub-area into which the Federal territory or, as the case may be, the relevant area is divided in pursuance of the First Schedule to this Act with the performance, in accordance with such conditions as the Lagos or area council may specify, of any of the functions of the Lagos or area council falling to be performed within the sub-area in question. 40

(6) If it appears to the Minister that any council established by this Act has failed to carry on its activities in a proper manner, he may provide that all the functions of that council, or such of those as may be specified by the order, shall be exercisable by the Minister or such other person as may be specified by the order, to the exclusion of the council, during such period as may be so specified ; 45

and an order under this subsection may require the making of payments to the Minister or the other person aforesaid, out of the fund established in pursuance of this Act, of such amounts specified by the order as the Minister considers appropriate for the purposes of the functions to which the order relates.

3.—(1) A person shall be a member of the Legion if—

Membership  
of the  
Legion.

(a) he applies to the Legion in the prescribed manner to be enrolled as such a member; and

(b) he satisfies the Legion that he is an ex-serviceman.

(2) It shall be the duty of the Legion—

(a) to establish and maintain a list of the persons who are for the time being members of the Legion; and

(b) to make arrangements for the issue to each member of the Legion of a membership card in the prescribed form bearing a photograph of the member to whom it is issued and stating his name and such other particulars (if any) as may be prescribed.

4.—(1) The Legion shall establish and maintain a fund from which there shall be defrayed all expenditure incurred by the Legion.

Financial  
provisions.

(2) There shall be paid or credited to the fund—

(a) such sums out of moneys provided by Parliament as Parliament may from time to time determine; and

(b) the assets of the association mentioned in section six of this Act which are transferred to the Legion in pursuance of that section; and

(c) all other assets from time to time accruing to the Legion.

(3) The fund shall be managed in accordance with rules made by the Minister and the Minister of the government of the Federation responsible for finance, acting jointly; and, without prejudice to the generality of the power to make rules conferred by this subsection, the rules shall in particular include provision—

(a) specifying the manner in which the assets of the fund are to be held and regulating the making of payments to and from the fund;

(b) requiring the keeping of proper accounts and records for the purposes of the fund in such form as may be specified by the rules;

(c) for securing that the accounts are audited periodically by an auditor appointed by the Ministers aforesaid, acting jointly;

(d) requiring copies of the accounts and of the auditor's report on them to be furnished to the Minister as soon as may be after the end of the period to which the accounts relate; and

(e) requiring the Minister to lay before each House of Parliament copies of all accounts and reports received by him in pursuance of the last foregoing paragraph.

5. It shall be the duty of the Legion to furnish to the Minister, as soon as may be after the end of each year, a report on the activities of the Legion during that year; and the Minister shall lay before each House of Parliament a copy of each report received by him in pursuance of this section.

Annual  
report.

Winding-up  
of N.E.W.A.

Cap. 136.

6.—(1) The Minister shall by order provide for the winding-up of the affairs of the association established by the Nigerian Ex-Servicemen's Welfare Association Act and for the transfer to the Legion of the assets and liabilities of the association ; and an order made in pursuance of this subsection may contain such incidental and supplementary provisions as the Minister considers expedient for the purposes of the order.

(2) When it appears to the Minister that the affairs of the said association have been wound up, he shall by order declare the association to be dissolved on such day as may be specified by the order ; and the enactments mentioned in the first and second columns of the Second Schedule to this Act are hereby repealed on the day so specified to the extent shown in the third column of that Schedule.

Interpreta-  
tion, etc.

7. In this Act, except in so far as the context otherwise requires, the following expressions have the meanings hereby assigned to them respectively, that is to say—

“ex-serviceman” means a person of African race who is normally resident in Nigeria and who is not a whole-time member of the armed forces of the Federation but has been either such a member or a whole-time member at any time before the first day of October, 1963, of the armed forces of the Crown ;

“functions” includes powers and duties ;

“the Lagos council” means the council established in respect of the Federal territory by paragraph 4 of the First Schedule to this Act ;

“the Minister” means the Minister of the government of the Federation charged with responsibility for ex-servicemen ;

“prescribed” means prescribed by regulations ; and

“regulations” means regulations made by the Minister.

Short title,  
extent and  
commence-  
ment.

8.—(1) This Act may be cited as the Nigerian Legion Act, 1964, and shall apply throughout the Federation.

(2) The provisions of this Act shall come into force on such day as the Minister may by order appoint, and different days may be appointed in pursuance of this subsection as respects different provisions.

## SCHEDULES

### Section 2.

#### FIRST SCHEDULE

Constitutions etc. of councils

#### *Area and sub-area councils*

1. The Minister may by order make provision for dividing each Region into areas, and each such area and the Federal territory into sub-areas, for the purposes of this Act.

2.—(1) There shall be established in respect of each sub-area a council consisting of such number of members as the Minister may by order specify for that sub-area, who, subject to the provisions of this Schedule, shall be elected by ex-servicemen resident in the sub-area from among their own number.

(2) Each sub-area council shall select a chairman of the council from among the members of the council.

3.—(1) There shall be established in respect of each area a council consisting of—

(a) the chairmen of the councils of the sub-area into which the area is divided ; and

5 (b) such number of other members as the Minister may by order specify for that area, who, subject to the provisions of this Schedule, shall be elected by ex-servicemen resident in the area from among such of their own number as are not members of a sub-area council.

10 (2) Each area council shall select a chairman of the council from among the members of the council.

#### *Councils for the Regions and Lagos*

4.—(1) There shall be established in respect of each Region and the Federal territory respectively a council consisting, in the case of a Region, of the chairmen of the councils of the areas into which the Region is divided and, in the case of the Federal territory, of—

(a) the chairmen of the councils of the sub-areas into which the territory is divided ; and

20 (b) such number of other members as the Minister may by order specify for the territory, who, subject to the provisions of this Schedule, shall be elected by ex-servicemen resident in the territory from among such of their own number as are not members of a sub-area council.

(2) Each council established by this paragraph shall select a chairman of the council from among the members of the council.

#### 25 *The national council*

5.—(1) There shall be established in respect of the Federation a council, to be known as the National Council of the Nigerian Legion, consisting of the following members, that is to say—

(a) two ex-servicemen nominated by the Minister ;

30 (b) the chairmen of the regional councils and the Lagos council ;

(c) six members of the regional council for Northern Nigeria selected by that council ;

(d) four members of the regional council for Eastern Nigeria selected by that council ;

35 (e) two members of the regional council for Western Nigeria selected by that council ;

(f) two members of the regional council for Mid-Western Nigeria selected by that council ; and

(g) two members of the Lagos council selected by that council.

40 (2) The Minister shall designate one of the two members of the national council nominated by him as the chairman of the council and the other of them as the vice-chairman of the council.

#### *Elections*

6.—(1) Provision may be made by regulations for the election of  
45 those members of councils who are required to be elected by ex-

servicemen, and, without prejudice to the generality of the powers conferred by the foregoing provisions of this paragraph, the regulations may provide—

- (a) for the preparation of lists of ex-servicemen qualified in accordance with the regulations to vote at elections; 5
- (b) for the delimitation of electoral wards;
- (c) for the nomination of candidates and for securing that no person is a candidate for election as a member of more than one council;
- (d) for the conduct of polls; 10
- (e) for declaring an election void as respects a council or an individual candidate; and
- (f) for the determination of questions arising in connection with an election.

(2) Regulations made in pursuance of this paragraph shall contain provision for ensuring that elections of members of councils are held at such time (not being earlier than the beginning of the period of three months ending with the time when existing members vacate office by the effluxion of time in pursuance of sub-paragraph (2) of the next following paragraph) as to secure that the results of the elections are, so far as practicable, declared before existing members vacate office as aforesaid. 15 20

(3) Nothing in the foregoing provisions of this Schedule shall be construed as preventing a person from being a candidate at an election held in pursuance of this Schedule by reason only of the fact that he is an existing member of a council. 25

#### *Tenure of office*

7.—(1) A person elected as a member of a council before the expiration of the year nineteen hundred and sixty-five shall take office as such a member at such time as may be prescribed; and a person so elected after the expiration of that year shall take office with effect from the time at which former members of the council in question last vacated office in pursuance of the next following sub-paragraph. 30

(2) All persons who, immediately before the expiration of the year nineteen hundred and sixty-six, hold office as members of councils shall vacate office at the expiration of that year; and all persons holding office as such members immediately before the expiration of the period of three years beginning with the first day of January, nineteen hundred and sixty-seven, or of any period beginning with that day which is a multiple of three years, shall vacate office on the expiration of that period. 35 40

(3) A member of a council (other than a person who is such a member by virtue of his being the chairman of another council) may at any time resign his office by notice in writing to the council.

(4) If it appears to the Minister, after such enquiry as he thinks fit, that a member of a council is incapable by reason of illness of performing the duties of his office or has conducted himself in such a manner as to be unfit to continue as a member of the council, the Minister may, by notice in writing to the council, declare the office of that member to be vacant. 45

(5) Regulations may provide for the filling of the office of a member of a council which has become vacant otherwise than by virtue of sub-paragraph (2) of this paragraph. 50

*Proceedings of councils*

8.—(1) Subject to the provisions of section twenty-six of the Interpretation Act, 1964 (which provides for the decisions of a statutory body to be taken by a majority of the members of the body and for the person presiding at a meeting of such a body to have a second or casting vote), the national council, each regional council and the Lagos council respectively shall make standing orders with respect to its proceedings.

(2) In exercising the power to make standing orders conferred by the foregoing sub-paragraph—

(a) the national council shall comply with any directions given to it in that behalf by the Minister ; and

(b) a regional council and the Lagos council shall comply with any directions given to it in that behalf by the national council ;

but nothing in this sub-paragraph shall be construed as derogating from the generality of subsection (5) of section one of this Act.

(3) Each regional council shall make standing orders with respect to the proceedings of the councils of the areas and sub-areas into which the relevant Region is divided in pursuance of this Schedule, and the Lagos council shall make standing orders with respect to the proceedings of the councils of the sub-areas into which the Federal territory is so divided.

(4) A council may, subject to the provisions of any standing orders having effect as respects the council, regulate its own procedure.

9. The quorum of the national council shall be twelve, and the quorum of any other council shall be equal to one third of the members of the council (any vacancy being treated as filled and any fraction being disregarded).

10.—(1) Subject to the provisions of any standing orders of the council, a council shall meet whenever it is summoned by its chairman ; and if the chairman is required so to do by notice given to him by a number of members of the council who constitute a quorum, he shall summon a meeting of the council to be held within seven days from the date on which the notice is given.

(2) At any meeting of a council its chairman shall preside while he is present, but if he is absent the members of the council present at that meeting shall select one of their number to preside at that meeting during his absence, so however that the vice-chairman of the national council shall, while he is present at a meeting of the council when its chairman is absent, preside at that meeting.

(3) Notwithstanding anything in the last two foregoing paragraphs or the foregoing provisions of this paragraph, the first meeting of each council shall be summoned in the prescribed manner and provision shall be made by regulations as to the person who shall preside and the procedure which shall be followed at that meeting.

11.—(1) At every meeting of a council there shall be recorded in the prescribed form minutes of the proceedings at the meeting.

copies of the minutes of a meeting of the national council, a council and the Lagos council shall, before the expiration of the fifteen days beginning with the date of the meeting, be furnished to the council in question to the Minister and—

- (a) in the case of a meeting of a regional council, to the Premier of the Region in question and to the national council ; and
- (b) in the case of a meeting of the Lagos council, to the national council.

*Miscellaneous*

12. The validity of any proceedings of a council shall not be affected by any vacancy in the membership of the council, or by any defect in the appointment of a member of the council, or by reason that a person not entitled to do so took part in the proceedings. 10

13. Any member of a council who has a personal interest in any matter proposed to be considered by the council shall disclose his interest to the council and, in so far as the standing orders of the council so provide, shall not vote on any question relating to that matter. 15

14. In this Schedule, except so far as the context otherwise requires, "council" means any council established by this Schedule.

Section 6.

SECOND SCHEDULE  
Enactments repealed

Chapter or number  
Cap. 157 of the 1948 edition of the Laws of Nigeria.  
L.N. 131 of 1954.

Short title  
The Nigerian Ex-Servicemen's Welfare Association (Vesting of Certain Charitable Funds) Act.  
The Adaptation of Laws Order, 1954.

*Extent of repeal*  
The whole Act.

Sub-paragraph (1) of paragraph 2 in its application to chapter 157 of the said edition of 1948, and so much of the Third Schedule as relates to that chapter.  
The whole Act.

Cap. 136.

The Nigerian Ex-Servicemen's Welfare Association Act.  
The Transfer of Functions (Lagos) Order, 1959.

L.N. 257 of 1959.

So much of the First Schedule as relates to chapter 156 of the said edition of 1948.  
The whole Act.

No. 42 of 1960.

The Nigerian Ex-Servicemen's Welfare Association (Amendment) Act, 1960.

1961, No. 67.

The Nigerian Ex-Servicemen's Welfare Association (Amendment) Act, 1961.

The whole Act.

L.N. 47 of 1961.

The Adaptation of Laws (Miscellaneous Provisions) Order, 1961.

So much of the Schedule as relates to chapter 136.

The Nigerian Legion which a

AN

EXPLANATORY MEMORANDUM

The object of this Bill is to abolish the rank of Queen's Counsel for the purpose of making amendments of the Legal Practitioners Act, 1962, consequential upon the abolition of that rank.

T. O. ELIAS,  
*Attorney-General of the Federation  
 and Minister of Justice*

**A BILL**

**FOR**

AN ACT TO ABOLISH THE RANK OF QUEEN'S COUNSEL ; AND FOR CONNECTED PURPOSES.

[ ]

Commence-  
 ment.

BE IT ENACTED by the Legislature of the Federation of Nigeria in this present Parliament assembled and by the authority of the same as follows :—

1.—(1) Any person upon whom there has been conferred the rank of counsel to Her Majesty as respects Nigeria shall cease to hold that rank on the commencement of this Act. Abolition of rank of Q.C.

(2) Accordingly, the Legal Practitioners Act, 1962, shall be amended as follows :— 1962, No. 33.

(a) the following provisions (which relate to the rank aforesaid) shall be omitted, that is to say—

in section two, subsection (2) ;

in section ten, subsection (6) ;

in the First Schedule, the words from the first "in" to "thereafter" in paragraph 2 ; paragraph 3 ; the words "not of counsel to Her Majesty" in paragraph 6 ; and the words "letters patent" ; and

(b) in subsection (2) of section four (which relates to practising fees) for the words "counsel to Her Majesty" there shall be substituted the words "ten or more years standing as a legal practitioner at the beginning of that year," and for the words "five years or more" there shall be substituted the words "more than five and less than ten years" ;

but no person shall, by virtue of paragraph (b) of this subsection, be entitled to a refund of any part of, or required to pay any sum in addition to, the practising fee previously paid by him in respect of the year nineteen hundred and sixty-four in pursuance of section four of the Act aforesaid.

2. This Act may be cited as the Queen's Counsel (Abolition) Act 1964, and shall apply throughout the Federation.



THE LAGOS EXECUTIVE DEVELOPMENT BOARD  
(POWERS) BILL

C 39

EXPLANATORY MEMORANDUM

The Lagos Executive Development Board is empowered by the Lagos Town Planning Act to undertake operations which are authorised by schemes made under the Act; but occasionally it is convenient for the Board to undertake the execution of other projects on behalf of the Federal government.

This Bill proposes to extend the powers of the Board retrospectively so as to enable it to undertake these projects as agent of the Federal government.

MUSA YAR'ADUA,  
*Minister of Lagos Affairs*

**A BILL**

**FOR**

AN ACT TO EXTEND THE POWERS OF THE LAGOS EXECUTIVE DEVELOPMENT BOARD; AND FOR CONNECTED PURPOSES.

[ ]

Commencement.

BE IT ENACTED by the Legislature of the Federation of Nigeria in this present Parliament assembled and by the authority of the same as follows :—

5 1.—(1) The Lagos Executive Development Board established by the Lagos Town Planning Act shall have, and be deemed always to have had, power to act as the agent of the President of the Republic and any Minister of the government of the Federation, on such terms as may be agreed between the Board and the President or the Minister in question, as respects any matter as respects which the President or  
10 the Minister has, either before or after the passing of this Act, requested the Board to act as aforesaid.

Extension of powers of Board. Cap. 95.

15 (2) References in the foregoing subsection to the President shall be construed, in relation to any period before the first day of October, nineteen hundred and sixty-three, as references to the Governor-General of the Federation.

2. This Act may be cited as the Lagos Executive Development Board (Powers) Act, 1964, and shall apply throughout the Federation.

Short title and extent.



REGISTERED LAND BILL  
EXPLANATORY MEMORANDUM

The need for a system of registration whereby titles to land might be more effectively secured to the individual owners in occupation or otherwise in control thereof has long been a matter of concern to Government. A working party set up by my ministry and consisting mainly of Nigerians experienced in land registration considered the subject some years ago, and the result of their deliberations are now embodied in this Bill.

The main object of this Bill is stability of title provided owners are in effective possession or control; and ownership in the first instance will be determined by an investigation of title unless title has already been established to the satisfaction of the officials to be appointed for the purpose.

The provisions of this Bill will come into effect where, under the powers conferred upon the Minister of Lagos Affairs he prescribes adjudication areas within the Federal territory. That done, the machinery provisions will enable investigations and enquiries to be made with the end result that new land registers will be constituted and titles guaranteed as to ownership so long as the owners shown by the land register remain in possession or retain effective control. They will also be guaranteed as to the area and the boundaries provided an adequate survey exists, although if there is none, the provision of a survey is to remain a matter for the individual owner or owners concerned in the mean time. The guarantee will take effect by means of an assurance fund to be established, and to which contributions will be made at a fixed rate on first bringing of land under the provisions of this measure.

Once a land register is constituted for a piece of land all other existing systems of registration will cease to apply, and accordingly the Acts referred to in the schedule in the Bill will cease to have effect. Thereafter instruments affecting any such land will need to be registered before interests claimed thereunder are fully operative; and until the happening of that event they will have effect mainly as contracts.

Miscellaneous provisions cover appeals to the Courts in appropriate cases; and the collection of fees on bringing of land under this measure will be deferred until a later date.

Other matters in the Bill are largely adaptations of existing law, although a change now sought to be introduced will mean that caveats and cautions as they operate under the present existing legislation will hereafter be known solely as caveats, and the provisions of this Bill relative to cautions under the Registration of Titles Act have been adjusted accordingly.

MUSA YAR'ADUA,  
*Minister of Lagos Affairs*



## REGISTERED LAND BILL



## ARRANGEMENT OF CLAUSES

*Clause*

## PART I—ADJUDICATION AREAS AND RECORDS

1. Power to prescribe adjudication areas, etc. and effect of order.
2. Appointment and powers of officers engaged in adjudication.
3. Subdivision of adjudication areas and notice.
4. Claims and attendance.
5. Stay of actions.
6. Lists of previously registered titles to be prepared.
7. Duties of demarcation officer.
8. Special powers of demarcation officer.
9. Duties and powers of registration officer.
10. Contents of adjudication record.
11. Principles of registration for adjudication record.
12. Procedure of ascertaining family representatives.
13. Notice of demarcation and registration.
14. Duties of adjudication officer.
15. Special powers of adjudication officer.
16. Evidence.
17. Adverse possession as basis of claim
18. Retention of documents.
19. Notice of completion of adjudication record.
20. Correction of errors.
21. Finality of registration.
22. Appeals.

## PART II—ORGANISATION AND ADMINISTRATION

*Land Registries and Officers*

23. Land registration district.
24. Land Registries.
25. Appointment of officers.
26. General powers of Registrar.
27. Seal of office.

*Land Registers*

28. The land register.
29. Notice of opening of land register to be given.
30. Manner of subsequent registration.
31. New editions of the land register.

*Maps Parcels and Boundaries*

32. Land Registry map.
33. Power of Registrar to require surveys and amend boundaries, etc.
34. Boundaries on Land Registry map not conclusive.
35. Maintenance of boundary marks.
36. Combinations and subdivisions.
37. Foreshore not included in title.
38. Alteration of contiguous parcels by subdivision, etc.

## PART III—EFFECT OF REGISTRATION

39. Interest to be conferred by registration.
40. Rights of proprietor.
41. Voluntary transfer.
42. Overriding interests.
43. Entries to give actual notice.

## PART IV—CERTIFICATES AND SEARCHES

44. Land certificate may be issued.
45. Land certificate to be produced with dealings.
46. Lost or destroyed land certificates.
47. Searches and copies.
48. Registration as evidence of signatures, etc.

## PART V—DISPOSITIONS

*General*

49. Subsequent dealings.
50. Protection of person dealing in registered land.
51. Additional fee for delayed registration.
52. Power to compel registration.
53. Priority of registered interests.

ARRANGEMENT OF CLAUSES—*continued**Clause*

54. Saving for other laws.
55. Stay of registration.
56. Merger of registered interests.
57. Dispositions by family representatives.

*Leases*

58. Term of leases.
59. Periodic tenancies.
60. Registration of leases.
61. Lease of charged land.
62. Reversionary leases.
63. Holding over.
64. Agreements implied in leases on the part of the lessor.
65. Agreements implied in leases on the part of the lessee.
66. Meaning of "in repair".
67. Forfeiture of lease.
68. Notice before forfeiture.
69. Relief against forfeiture.
70. Variation and extension of leases.
71. Substitution of leases.
72. Subleases.
73. Surrender of leases.
74. Determination of leases.

*Charges*

75. Form and effect of charges.
76. Second or subsequent charges.
77. Charges by companies.
78. Agreements implied in charges.
79. Variation of charges.
80. Right of redemption.
81. Notice in case of default.
82. Power of sale under a charge.
83. Application of purchase money.
84. Appointment and duties, etc., of receiver.
85. Foreclosure.
86. No right of entry into possession on default.
87. Discharge of charge.
88. Satisfaction of charge.
89. Tacking and further advances.
90. Consolidation.
91. *No lien* by deposit only of land certificate.

*Transfers*

92. *Mode of transfer.*

93. Transfer of part.
94. Implied covenants, etc., on transfer of lease.
95. Restriction on transfer, etc., of lease if consent required.
96. Implied covenants, etc., on transfer of charged land.

*Easements, Restrictive Covenants and Profits a Prendre*

97. Grants of easements.
98. Restrictive covenants.
99. Profits a prendre.
100. Release, etc., or easements, restrictive covenants and profits.

*Proprietorship and Partition*

101. Registration and proprietorship.
102. Joint proprietors and severance of interest.
103. Proprietorship in common.
104. Partition.
105. Power for Registrar to order sale.
106. Procedure where share is small.

*Testamentary dispositions, etc.*

107. Testamentary dispositions, etc., not affected.

## PART VI—INSTRUMENTS AND AGENTS

108. Form of instruments.
109. Execution of instruments.
110. Proof of execution.
111. Instruments to be stamped.
112. Disposal of instruments.
113. Minors and registered land.
114. Agents for persons under disability.
115. Powers of attorney.

## PART VII—TRANSMISSIONS, TRUSTS AND FAMILY REPRESENTATION

116. Transmission on death.
117. Registration by personal representatives not on land register.
118. Applications for registration on death of proprietor, etc.
119. Effect of transmission by death.
120. Effect of transmission on bankruptcy.
121. Effect of notice of liquidation.
122. Registration of transmission by expropriation, etc.
123. Trust not to be entered in land register.

*Section*

124. Trustees with no survivorship.
125. Appointment of family representatives.
126. Removal and replacement of family representatives.
127. Effect of registration of family representatives.
- PART VIII—JUDGMENTS AND WRITS OF EXECUTION
128. Power to register judgments, etc.
129. Effect of registration of judgment, etc.
130. Cancellation of registration of judgment, etc.
131. Sale in execution.
- PART IX—CAVEATS ETC.
132. Caveats generally.
133. Other prohibitions on registration.
- PART X—ADVERSE POSSESSION AND PRESCRIPTION
134. Acquisition of land by adverse possession.
135. Principles of possession.
136. Acquisition of easements, etc., by prescription.
137. This Part not to apply to registered land.
- PART XI—REGISTERED LAND ASSURANCE FUND AND RECTIFICATION OF LAND REGISTER
138. Assurance Fund.
139. Payment to Assurance Fund on first registration.
140. Rectification by Registrar.
141. Rectification by court.
142. Right to indemnity.
143. Costs, etc., on any claim.
144. Restriction on claims in respect of surveys.
145. Amount of indemnity.
146. Power to enforce covenants where indemnity paid.
- PART XII—DECISIONS OF REGISTRAR AND APPEALS
147. Power for Registrar to state a case.
148. Appeals against decision of Registrar.
149. Effect of notice of appeal on dispositions.
150. Power to make rules of court.
- PART XIII—MISCELLANEOUS AND TRANSITIONAL
151. Certification of documents.
152. Registration fees.
153. Addresses of caveators and others to be given to Registrar.
154. Service of notices.
155. Hearings and opportunity of being heard.
156. Indemnity of officers.
157. Offences.
158. Additional powers of Registrar.
159. Recovery of unpaid fees etc.
160. Enforcement of Registrar's orders for payment.
161. Regulations.
162. Registration of instruments in special cases.
163. Restricted application of other Acts.
164. Interpretation.
165. Short title, application and commencement.
- SCHEDULE—Enactments affected.



## A BILL

### FOR

AN ACT TO PROVIDE FOR THE MORE EFFECTIVE REGISTRATION OF LAND AND TITLES AND FOR MATTERS CONNECTED THEREWITH.

[Section 16(52)]

Commence-  
ment.

BE IT ENACTED by the Legislature of the Federation of Nigeria in this present Parliament assembled and by the authority of the same as follows :—

#### PART I.—ADJUDICATION AREAS AND RECORDS

5       1.—(1) If it appears to the Minister to be expedient to provide for the adjudication of interests in land or rights in land in the Federal territory and for the registration of titles thereto, the Minister may by order declare the whole or any part of the Federal territory to be an adjudication area for the purposes of this Act ; and upon publication of  
10 the order in the Gazette, this Act shall apply to the adjudication area so declared and have effect accordingly.

Power to  
prescribe  
adjudication  
areas, etc.  
and effect  
of order.

      (2) An order under this section shall define the situation and limits of the adjudication area to which it relates either by means of a plan or by description ; and shall provide that the demarcation of parcels and  
15 presentation of claims to interests in land or rights in land within the adjudication area may begin at any time after a period to be prescribed.

      (3) Where by reason of an order made under this section this Act is to apply and lists of titles are prepared for the purposes of an adjudication, no instrument or other document whatsoever shall be registered under  
20 the Land Registration Act or the Registration of Titles Act as the case may be, before the compilation of the land register for the appropriate section of the adjudication area, without the consent in writing of a registration officer.

Cap. 99.  
Cap. 181.

      (4) In this section, “interests in land” includes encumbrances.

25       2.—(1) There shall be appointed a fit person to be an adjudication officer for the purposes of this Act who shall be an officer of the High Court and shall have power to inquire into and adjudicate upon claims to land and interests in land within the adjudication area for which he was appointed or, subject to the terms of his appointment, for any adjudica-  
30 tion area.

Appointment  
and powers  
of officers  
engaged in  
adjudication.

      (2) An adjudication officer shall in respect of claims to land within an adjudication area have all the powers of a judge of the High Court, and shall exercise general control over all adjudications.

35       (3) There shall also be appointed for the purposes of demarcation of and registration of title to land subject to this Act, fit persons as demarcation officers and registration officers, who shall have the powers conferred upon such officers by this Part of this Act.

(4) Any demarcation officer may at all reasonable times enter upon land within an adjudication area for the purpose of demarcating or surveying land within such area; and for such purpose may require persons likely in his opinion to have the knowledge, to give information regarding the boundaries of any such land. 5

(5) Any registration officer for the purposes of an inquiry under this Part of this Act may administer oaths and issue summonses, notices, or orders requiring the attendance of persons or the production of documents which he may consider necessary for any adjudication of claims under this Part of this Act. 10

(6) An adjudication officer may if he thinks fit exercise all or any of the powers and duties conferred upon demarcation officers and registration officers by this Part of this Act.

Subdivision  
of adjudica-  
tion areas  
and notice.

3.—(1) The adjudication officer may subdivide an adjudication area into adjudication sections and, where any such subdivision is made, separate notices in respect of each adjudication section shall be published by the adjudication officer in such manner as he thinks fit. 15

(2) A notice for publication under this section shall—

(a) fix a time within which persons claiming to be interested in land within the adjudication section are to present their claims; and 20

(b) require any person making a claim to land the boundaries of which are not defined with reasonable accuracy, to point out to a demarcation officer the boundaries or boundary marks of the land affected;

and as the case may require, the notice shall— 25

(c) specify as nearly as possible the situation and limits of the adjudication section;

(d) state that rights to and interests in land within the adjudication section will be ascertained in accordance with the provisions of this Part of this Act and where so ascertained shall be registered under this Act; 30

(e) state that rights to and interests in land within the boundaries of the adjudication section which are registered under the Registration of Titles Act will be brought on to the land register under this Act without requiring any formal application by persons interested; 35

(f) confirm that if the name of a person appears in the list of owners prepared by the registration officer under this Part of this Act in respect of land in the adjudication section affected by the Land Registration Act as unregistered land and published as a schedule to the notice, the claim will be investigated by the registration officer, without the necessity for any claim by any such person. 40

Cap 181

Cap. 99

Claims and  
attendance.

4.—(1) Persons other than those named in the schedule to a notice published under section three of this Act claiming unregistered rights or interests in land within an adjudication section shall present their claims within the time limited by the notice. 45

(2) Any person required by an officer under this Part of this Act to attend for purposes of or incidental to an adjudication, may appear or be represented by a duly authorised agent at the time and place required by such officer; and the person appearing or so represented shall produce to, and in proper case be given, an official receipt by the adjudication officer for any document or paper affecting or relating to his claim to land within the adjudication section. 50

(3) The demarcation, registration or adjudication of land within an adjudication section may proceed or, if begun may continue, notwithstanding the failure by any person to attend when required under this section.

5 (4) If an officer is satisfied in respect of any unregistered land in an adjudication section that claims are outstanding he may, if he thinks fit, require the attendance of any person appearing to be entitled, and deal with such land as if a claim had been duly made by or on behalf of any such person.

10 (5) Where a deceased claimant or owner is represented by one or more heirs or, in the case of separate group interests, by one or more of a group of heirs, in respect of a claim to land or an interest therein in any adjudication section, the appearance of such heirs or groups as the case may be in person or by duly authorised agents shall, unless the adjudication officer otherwise directs, be deemed to be an appearance by all the heirs or groups.

20 5.—(1) Subject to the provisions of this section, an action concerning land or rights therein in any adjudication section shall not be commenced in any court without the consent in writing of the adjudication officer. Stay of actions.

25 (2) Where an action is commenced in any court before notice is given of intention to adjudicate upon claims under this Part of this Act the action shall, if it is one for the recovery of premises, be completed before the adjudication ; but otherwise the action shall, subject to any direction of the court, be transferred to and be determined by the adjudication officer sitting as a court. If any action is so transferred, the fee payable in respect of the hearing before the adjudication officer shall be the fee which would have been payable to the High Court if the case had not been so transferred ; and the fee shall be paid and credited accordingly.

30 6. Where an order is made declaring an adjudication area, the registrar of titles appointed under the Registration of Titles Act shall prepare a list of the titles registered under that Act and relating to land in the adjudication area, and shall provide the adjudication officer with such other information as the adjudication officer may from time to time require in respect of any such registered title. List of previously registered titles to be prepared. Cap. 181

7. Subject to any directions which may from time to time be given by the adjudication officer, it shall be the duty of a demarcation officer— Duties of demarcation officer.

40 (a) to see that the boundaries of each separate parcel of privately owned land and of public roads, rights of way and water, and of graveyards, (if not already demarcated by a physical feature), are properly demarcated or indicated ;

(b) to submit to the adjudication officer, boundary disputes which the demarcation officer is unable to resolve ;

45 (c) to demarcate the boundaries of all waste or unoccupied land ;

(d) to prepare in respect of every adjudication section a plan (in this Act referred to as a "demarcation plan") showing thereon every parcel of land however owned, and marked so as to identify the parcels by means of a distinguishing number for each parcel ;

- (e) to show on the demarcation plan by means of a distinct colour or otherwise howsoever every parcel, the title to which is registered under the Registration of Titles Act.
- Cap. 181.
- Special powers of demarcation officer.
- 8.—(1) In the performance of his duties, a demarcation officer may—
- (a) if the boundary between separate parcels of land is curved or irregular or, in his opinion, if the boundary is otherwise inconvenient for the use of the land, re-align the boundary, and where necessary adjust the rights of the owners of the land affected by the exchange of land or by the payment of money ;
- (b) demarcate any right of way necessary to give access to a public road in favour of any parcel of land completely surrounded by other parcels ;
- (c) with the agreement of the owner or owners, group together in one or more parcels, separate areas of land owned by such owner or owners, if such grouping does not adversely affect the parcel of other persons.
- (2) Where a boundary is re-aligned under this section the adjudication officer shall satisfy himself that the compensation is adequate, and in any proper case shall certify it as one in respect of which the person affected may appeal to the High Court.
- Duties and powers of registration officer.  
Cap. 99.
- 9.—(1) A registration officer shall, when appointed, examine with all convenient speed such of the records or instruments kept in the land registry under the Land Registration Act as he considers relevant to land in the adjudication area, or section thereof, as the case may be.
- (2) If after such examination the registration officer is satisfied that any person has a claim to or any right or interest in unregistered land within an adjudication section, he may, in his discretion prepare for publication with the notice under section three of this Act a list of owners showing the names of all persons so far as are known to him, the parcels of land concerned, and the nature of the rights or interests to which any claims relate.
- (3) After the time limited by the notice referred to in subsection (2) of this section has expired, the registration officer shall consider all claims presented in accordance with the notice or the schedule thereto and, after such investigation as he considers necessary, the registration officer shall prepare a record (in this Act referred to as “the adjudication record”) in such form as the adjudication officer may approve in respect of every parcel of land shown on the demarcation plan which is not registered under the Registration of Titles Act.
- Cap. 181.
- (4) If there are two or more claimants to any land or right in land within an adjudication section and the registration officer is unable to effect agreement between them he shall submit the case with particulars of the claim for hearing by the adjudication officer.
- (5) The registration officer shall make any registration or re-registration and shall rectify the adjudication record in accordance with any order of the adjudication officer under this Act.
- (6) The registration officer in the performance of his duties under this Act shall be subject to any general or special directions of the adjudication officer.

10.—(1) An adjudication record shall consist of forms each of which shall relate to a parcel of land within the adjudication section and contain the following particulars that is to say—

Contents of  
adjudication  
record

5 (a) the number of the parcel of land as shown on the demarcation plan and its approximate area ;

(b) the name and description of the owner and the limitation (other than disability) on his power of dealing with the land ;

10 (c) if any owner or other person is under a disability, by reason of age, unsoundness of mind or otherwise howsoever the name of his guardian ;

15 (d) details of any lease, right of occupation, charge or other encumbrance or interest whatsoever amounting to less than ownership affecting the land, whether by virtue of customary law or otherwise, together with the name and description of every person entitled to the benefit thereof and particulars of any restriction on his power of dealing with it ;

(e) the fact that in any particular case the land is state land ; and

(f) the date on which the form is completed.

20 (2) Every form shall be signed by the registration officer and by the owner of the land or of any lease or charge or by the duly authorised agent of such owner, unless the adjudication officer in his discretion dispenses with the signature of the owner or his agent.

11.—(1) If the registration officer is satisfied when preparing an adjudication record—

Principles of  
registration  
for adjudica-  
tion record.

25 (a) that the right or interest of any person in land is such as would entitle him to be registered under this Act as the proprietor of that land, the registration officer shall enter the name of that person accordingly : Provided that the exercise by any person of rights in or over one or more parcels of land shall not be construed as conferring upon  
30 such person rights of ownership in or over any greater extent of land than that in or over which the rights are exercised ;

(b) that no person is entitled to exercise rights of ownership over defined land or that the rights enjoyed by any person thereover would be insufficient to entitle such person to be registered under this Act as the proprietor of that land, the registration officer shall record the land as state land ;

35 (c) that the right or interest of any person in or over land which is privately owned or in or over state land would be insufficient to entitle such a person to be registered under this Act as the proprietor of that land, but would entitle any such person to the benefit of any other  
40 registrable interest, the registration officer shall record such right accordingly with a note of the limits within which the right may be exercised, the extent to which the benefit thereof may be dealt with, and such other particulars as may be necessary to define the nature,  
45 incidence and extent of the right.

(2) The registration officer shall, if land is owned by two or more persons, ascertain whether they hold as joint tenants or as tenants in common and, if as tenants in common and the shares are not equal, the share of each such owner.

(3) If the land is family land, the registration officer shall, subject to the next succeeding section of this Act,—

(a) register the names of all members of the family who are entitled to a share therein together with the size of the share of each such member ; or

(b) if the number of members of a family exceeds twenty or the majority of such members so requests, register the name of the family and the names of representatives of the family who jointly are to have the exclusive rights and powers and be the registered proprietors for the purpose of any dealing with the land or any part thereof or interest therein subject to this Act and to such restriction as, in any particular case, the registration officer may deem it necessary to impose.

Procedure  
for  
ascertaining  
family repre-  
sentatives.

12.—(1) Where in the case of family land not more than twenty names are submitted to the registration officer as the names of persons to represent a family, and no objection thereto is offered by any member of the family, the registration officer shall enter such names in the adjudication record as the family representatives.

(2) Where in the case of family land no names or more than twenty names are submitted, or where there is an objection to a member of the family, the registration officer shall refer the case to the adjudication officer for his opinion ; and after considering any custom prevailing within the family and the opinion of the adjudication officer, the registration officer shall appoint not more than twenty persons as family representatives.

(3) Where land is owned by a family and the adjudication officer is not satisfied that any custom exists in relation to the family land, the adjudication officer shall direct the holding of a family meeting not later than twenty-one days after delivery of the direction to the head of the family or his representative, requiring the family to elect not more than twenty persons to be the family representatives. The head of the family or his representatives shall cause all adult members of the family, so far as possible, to be notified accordingly, and when held, all adult members present at the family meeting shall be entitled to vote ; but the fact that any member of the family fails to receive notice of or to attend such meeting shall not invalidate the meeting. If the number of names of the persons elected as family representatives at the family meeting is not more than twenty, notice thereof with a list of the names with sufficient other information which the adjudication officer may reasonably require shall be forwarded by the head of the family or his representative to the adjudication officer not later than seven days after the meeting ; and if he is satisfied that the family meeting was properly held, the adjudication officer shall enter those names as the family representatives in the adjudication record.

(4) If no agreement is reached, the adjudication officer shall record the land as family land ; and when so recorded it shall have the effect of a caveat under this Act and no dealing with the land may be registered until such time as the family representatives are ascertained.

13. At least six clear days before demarcation is to begin, the demarcation officer shall, as directed by the adjudication officer, give notice of the intended time and place of the demarcation and of registration thereafter to persons likely to be affected thereby.

Notice of  
demarcation  
and registra-  
tion.

14.—(1) The adjudication officer shall supervise every adjudication, and shall hear and decide—

Duties of the adjudication officer.

5 (a) any dispute as to ownership or as to boundaries of land within the adjudication area or as to any lease, charge or other encumbrance whatsoever affecting such land if the demarcation officer or the registration officer as the case may be has been unable to resolve the dispute ;

(b) any petition—

10 (i) in respect of an act or decision of a demarcation officer, or  
(ii) to rectify an original entry in the adjudication record prepared by a registration officer under the provisions of section nine of this Act.

15 (2) The adjudication officer shall on the hearing of a dispute or petition under this section record the proceedings in such form as he thinks necessary ; and the procedure on the hearing of a civil suit shall, as far as practicable be followed and the fees prescribed for any such hearing shall be the fees payable.

15. In the course of an adjudication, the adjudication officer may—

Special powers of adjudication officer.

20 (a) give such instructions as he thinks necessary to implement the provisions of this Part of this Act relating to the procedure to be followed when demarcating or registering land within an adjudication area ;

25 (b) direct the owner of land to enclose it by means of a boundary wall, fence or hedge or prescribe the demarcation of the boundaries in some other permanent manner ;

30 (c) where persons, whether or not heirs of a deceased owner, jointly claim land as co-owners, order a partition of the land amongst such persons in accordance with an agreement approved by the adjudication officer or, if there is no agreement, as the adjudication officer may direct ;

and any person concerned or affected shall comply with the terms of any instruction, direction, or order, as the case may be, given or made by the adjudication officer.

35 16.—(1) The adjudication officer may act on any testimony sworn or unsworn, and may receive as evidence any statement, document information or matter which in his opinion may assist him to deal effectively with the matters before him, whether the same would, apart from this section, be legally admissible evidence or not.

Evidence

40 (2) Subject to the foregoing provisions of this section, the Evidence Act shall apply to all proceedings before an adjudication officer in the same manner as if he were a court within the meaning of that Act.

Cap. 62.

45 17. It is hereby declared that a claim under this Part of this Act based on acquisition by adverse possession or prescription may be made ; and if it is accepted by the adjudication officer, it shall be registered in like manner as if it were ordinary claim under this Act.

Adverse possession as basis of claim.

18. The adjudication officer and the registration officer as the case may require shall retain all documents of title produced in respect of any claim :

Retention of documents.

Provided that if any document of title produced to any such officer includes unregistered land not comprised in the claim, it shall be not retained; and the adjudication officer after endorsing thereon a note of the claim shall return the document to the person producing it.

- Notice of completion of adjudication record. 5
19. Where the adjudication record in respect of any adjudication section has been completed, the adjudication officer shall sign and date a certificate to that effect, and unless a petition on appeal is filed, shall forthwith thereafter give notice of the completion of such adjudication record and of the place at which it may be inspected during office hours.
- Correction of errors. 10
20. The adjudication officer of his own motion may at any time correct clerical errors or errors of a minor nature in the adjudication record.
- Finality of registration. 15
21. Subject to any appeal under this Part of this Act, registration as entered in the adjudication record shall, after the expiration of thirty days from the date of the certificate of the adjudication officer, be final and the Registrar of Land under this Act shall thereafter compile editions of the land register from such record.
- Appeals. 20
- 22.—(1) Any person aggrieved by any act or decision of a demarcation officer or by any entry in the adjudication record made by the registration officer may at any time before notice of the completion of the adjudication record has been given, petition the adjudication officer in respect of any such act, decision or entry; and the provisions of section fourteen of this Act shall have effect, and the petition may be dealt with accordingly.
- 25
- (2) Any person aggrieved by any act or decision of the adjudication officer may appeal to the High Court within thirty days from the date of the certificate given on completion of the adjudication record in respect of the adjudication section concerned, or within such extended time as the High Court, if it thinks necessary in the interest of justice, may allow. 30

## PART II.—ORGANIZATION AND ADMINISTRATION

### *Land Registries and Officers*

- Land registration districts. 35
- 23.—(1) The Minister may at any time by order in the Gazette constitute the Federal territory or any adjudication area therein a land registration district; and upon the making of the order, all land affected by a final adjudication record as well as land duly registered under the Registration of Titles Act shall be included in the appropriate land registration district and may be registered accordingly under this Act.
- Cap. 181. 40
- (2) Until the Minister constitutes a land registration district under subsection (1) of this section, the land registration district which, immediately before the coming into operation of this Act was in existence in the Federal territory, shall be deemed to be the land registration district for the purposes of this section.
- 45
- (3) The boundaries of any land registration district may at any time by order of the Minister be amended for the purpose of constituting any new land registration district or of adjustment of boundaries of any existing land registration district.

24. There shall be maintained in every land registration district a Land Registry which shall form part of the High Court and in which there shall be kept in accordance with the provisions of this Act—

Land  
Registries.

- (a) a register of land to be known as the land register ;
- 5 (b) a map to be known as the Land Registry map ;
- (c) parcel files containing the instruments, which support subsisting entries in the land register, and any filed plans and documents ;
- 10 (d) a book in the prescribed form to be known as the presentation book in which shall be recorded all applications numbered consecutively in the order in which they are presented to the land registry ;
- (e) a record to be known as the mutation record ;
- (f) an index to be known as the Nominal Index in which shall be kept in alphabetical order a record of the names of the proprietors (other than banks, building societies and such corporations as the Registrar may from time to time direct) of land, leases and charges of any description with such information as to the parcels affected and necessary to identify ;
- 15 (g) a power of attorney index.

20 25.—(1) There shall be appointed as a member of the Public Service of the Federation a fit person to be Registrar of Land and such person shall, under the general direction of the Chief Justice of Lagos have the control of and administer all Land Registries under this Act.

Appointment  
of officers.

25 (2) There shall also be appointed as members of such public service a deputy registrar of land and in respect of every Land Registry such assistant registrars and other officers or employees as may be necessary for carrying out the provisions of this Act.

30 (3) The deputy registrar shall have all the powers of the Registrar under this Act ; but unless for any reason the Registrar is unable to exercise the power, a deputy registrar shall not have the power of delegation conferred by the next succeeding subsection.

35 (4) The Registrar may by instrument under his hand delegate to any assistant registrar any of the powers of the Registrar under this Act other than the power to delegate, and may at any time likewise revoke or vary any such delegation ; but the fact that the Registrar has delegated any power under this subsection shall not preclude the Registrar from himself exercising the power.

40 (5) The person holding office at the commencement of this Act as registrar of titles shall be deemed to have been appointed Registrar of Land under subsection (1) of this section ; and all other persons who at the commencement aforesaid are officers or employees of the land registry established under the Registration of Titles Act shall, unless the Public Service Commission otherwise directs in respect of a particular office or employment, be deemed to have been appointed to the like offices or positions under this Act.

Cap. 181

45 26. The Registrar, and every assistant registrar to the extent to which any powers are delegated to him shall have and may exercise the following powers additional to any other powers conferred by this Act, that is to say—

General  
powers of  
Registrar.

(a) he may in respect of any particular parcel of land or encumbrance require the proprietor or any person to produce any instrument, certificate or other document or plan relating to the land, or encumbrance and the proprietor or other person as the case may be, shall produce the same ;

5

(b) he may summon a proprietor or other person interested to appear and give information respecting any land, encumbrance or other instrument, certificate, document, or plan relating to the land of the proprietor or encumbrance affecting the land, and the proprietor or other person as the case may require, shall appear and give the information ;

10

(c) he may refuse to register any deed or document presented to him if any instrument, certificate or other document or plan or information required by him to be produced or given is withheld or anything required by him to be done under this Act is not so done.

15

(d) he may administer oaths or affirmations and may require that any proceedings, information or explanation affecting registration to be verified on oath or affirmation ;

(e) he may order that the costs, charges and expenses incurred by him or by any other person in connection with any investigation or hearing held by him for the purposes of registration under this Act shall be borne and paid by such persons and in such proportions as he may think fit.

20

1963 No. 23. (2) Where the Registrar or any assistant registrar under this section is empowered to administer oaths or affirmations any such officer may take a statutory declaration under the Oaths Act 1951 in substitution therefor, and in any case where an oath or affirmation is administered or declaration is taken no oath fee or stamp duty as the case may be, shall be payable or be paid.

25

Seal of office.

27. There shall be a seal of the Land Registry showing the Coat of Arms and such reference on the surmount to the Land Registry as the Chief Justice of Lagos may approve in writing. Every instrument bearing the imprint of such seal shall be received in evidence by all courts and persons ; and, unless the contrary be shown, it shall be deemed, without further proof, to have been duly sealed and issued by or under the direction of the Registrar.

30

### Land Registers

The land register.

28.—(1) The Registrar may divide a registration section into registration sections and open land registers for every edition and accordingly all land dealt with at the time of an edition in respect of a registration section which is included therein (whether or not also included in the adjudication record) shall be entered in the land register, and a parcel of land and every interest therein shall comprise editions of that part of the land register.

(2) The Registrar shall compile the land registers in the following manner, that is to say—

Cap. 181.

(a) for every parcel of land or as the case may be, registered under the Registration of Titles Act the land register shall show all editions showing all subsisting interests registered

(b) for every parcel of land included in an adjudication record under the provisions of Part I of this Act and not registered under the Registration of Titles Act—

5 (i) every person entitled in the adjudication record to ownership shall be registered as proprietor of the parcel recorded in his name therein subject to any limitation, restriction, or encumbrance affecting the parcel of land ;

10 (ii) where no owner has been found, the parcel shall be registered as state land subject to any rights or interests in respect of it shown in the adjudication record ;

(iii) in any other case, the person named in the adjudication record as entitled to the benefit of any rights or interests in any parcel shall, subject to any overriding interest under this Act affecting the right or interest, be registered accordingly.

15 (3) If the boundaries of a parcel of land are fixed otherwise than by a survey approved by the Federal Director of Surveys, the Registrar may in his discretion endorse and sign on the appropriate land register a note that it is issued limited as to parcels ; and where the register is so noted, the provisions of this Act as to rectification of boundaries shall  
20 have effect accordingly.

29.—(1) The Registrar shall as soon as may be after the opening of an edition of the land register under section twenty-eight of this Act, give notice in writing of the fact to all persons having registered interests in any land or lease included therein. Notice of opening of land register to be given.

25 (2) On receipt of a notice under this section the owner of a title formerly registered under the Registration of Titles Act shall surrender his certificate of title to the Registrar and, if entitled, shall receive a land certificate under this Act in substitution for such certificate of title. Cap. 181.

30. Registration of any instrument under this Act (other than of an instrument as the basis of title in respect of the bringing of land under this Act) shall on payment of the prescribed fees be effected by an entry in the appropriate edition of the land register made in such form as the Registrar may from time to time direct. Manner of subsequent registration.

31. If the number or the nature of the entries so require or the Registrar thinks fit, the Registrar may at any time open a new edition of a land register in substitution for the existing edition. The substituted edition shall show subsisting entries ; and all other entries that have been determined or have ceased to have any effect shall be omitted. New editions of the land register.

#### *Maps, Parcels and Boundaries*

32.—(1) There shall be compiled from the demarcation plans a map to be called the Land Registry map showing the boundaries of each parcel of registered land and such other information as the Registrar may direct or require ; and such map shall be drawn to a scale and shall be printed on as many sheets as the Registrar thinks necessary. Land Registry map.

(2) Where the Registrar divides a registration district into registration areas, he shall cause the division to be shown on the Land Registry map and shall identify the sections by distinctive names. Any registration area may be further divided by the Registrar into areas to be known as sub-sections which shall be shown on the said map and be given distinctive numbers, letters, or a combination of numbers and letters, as the Registrar may direct.

(3) The Registrar may, at any time, combine or divide registration sections or blocks, or vary their boundaries.

(4) The parcels of land in each registration section or block shall be numbered consecutively and the name of the registration section and the number and letter of the block (if any) and the number of the parcel shall together be a sufficient reference to any parcel.

(5) A plan may at any time be filed in respect of any parcel to augment the information available from the Land Registry map; and the filing of such plan shall be noted where directed by the Registrar.

Power of Registrar to require surveys and amend boundaries, etc.

33.—(1) The Registrar may require a survey of any land to be made for the purposes of this Act and, subject to the provisions of this section, may with the agreement in writing of any person liable to be affected thereby, alter or replace the Land Registry map or any part thereof as a result of such survey.

(2) There shall be a form to be known as a mutation form, and no alteration of any boundary shown on the Land Registry map shall be made except as directed by the Registrar by means of a mutation form, which shall thereafter be filed in the Land Registry.

(3) Where the boundary of a parcel is altered, its parcel number shall be cancelled and it shall be given a new number.

(4) The Registrar may, at any time, direct the preparation of a new edition of the Land Registry map or any part thereof; and matter which the Registrar considers obsolete, may be omitted from any such new edition.

Boundaries on Land Registry map not conclusive.

34.—(1) The Land Registry map shall not be final and conclusive evidence as to the precise position of any boundary; and where any uncertainty or dispute arises as to the position of a boundary the Registrar, on the application of any interested party, shall give all persons appearing by the land register to be affected an opportunity of being heard; and on such evidence as he considers relevant, the Registrar shall ascertain and fix the position of the uncertain or disputed boundary by survey or by description as the case may require.

(2) Where the Registrar exercises his power under subsection (1) of this section, he shall make a note to that effect on the Land Registry map and in the appropriate editions of the land register and shall file such plan or description as may be necessary to record his decision.

(3) No court shall entertain any action or other proceeding relating to a dispute as to the boundaries of registered land unless the dispute has been dealt with in the first instance by the Registrar under this section.

Maintenance of boundary marks.

35.—(1) The Registrar may at any time by order in writing direct which of adjoining proprietors shall be responsible for the care and maintenance of a boundary mark; and when so directed, the proprietor designated shall maintain in good order the boundary marks on his land.

(2) Any proprietor responsible for the maintenance of boundary marks who allows a boundary mark to fall into disrepair or be destroyed or removed shall be guilty of an offence and liable on conviction to a fine of ten pounds.

(3) Any person who defaces, removes, injures or otherwise impairs any boundary mark unless authorised to do so by the Registrar in writing, shall be guilty of an offence and liable on conviction to a fine of twenty pounds or to imprisonment for a term of three months, or to both.

(4) Any person convicted of an offence under this section shall, whether or not any penalty therefor is imposed upon him, be liable to pay the cost of restoring such boundary marks; and the cost of the restoration may in proper case be recovered as a civil debt by any person responsible under this section for the maintenance of boundary marks on the land affected.

(5) For the purposes of this section, "boundary mark" includes any fence, hedge, stone, pillar, (whether survey pillar, peg, pin or tube) or wall or other mark whatsoever which serves to demarcate the boundary of land.

36. Subject to the provisions of this Act, where—

(a) contiguous parcels of registered land are owned by the same proprietor and are subject in all respects to the same rights and obligations, the Registrar on the application of such proprietor, may combine the parcels by closing the editions relating thereto and opening new editions in respect of the parcels resulting from such combination;

(b) the proprietor of unencumbered land applies for the division of it into two or more parcels and the Registrar is satisfied that the land is free from incumbrances and is suitable for such division, the Registrar shall give effect to the application by means of a mutation record and by the closing of any relevant edition and the opening of new editions in the land register.

37. It is declared that land below high water mark at ordinary spring tides shall in the case of any seaward or tidal river boundary be deemed to be excluded from any parcel of land in the land register unless the contrary is expressly noted in the relevant edition of the land register.

38.—(1) On the application of the proprietors of contiguous parcels of registered land who are desirous of subdividing or altering the boundaries thereof, the Registrar may if satisfied that all necessary consents in writing of other persons in whose names any right or interest in such parcels is registered and of any caveator have been given and are produced, and subject to the provisions of this section, give effect to the application by means of a mutation record and cancel the relevant editions relating to such parcels and prepare new editions in accordance with the scheme of subdivision or alteration of boundaries, as the case may require.

(2) If in the opinion of the Registrar any alteration of contiguous parcels under this section would involve substantial changes of ownership which should be effected by transfer under this Act without invoking the provisions of this section, he may, in his absolute discretion, refuse to give effect to the application.

(3) Where any boundary is subdivided or altered under this section, the new parcels shall, anything to the contrary in this Act notwithstanding, vest in the persons in whose names they are registered without further authority than this section.

Combina-  
tions and  
sub-  
divisions.

Foreshore  
not included  
in title.

Alteration of  
contiguous  
parcels by  
sub-  
division, etc.

## PART III.—EFFECT OF REGISTRATION

## 39.—(1) Subject to the provisions of this Act,—

Interest to  
be conferred  
by  
registration.

(a) the registration of any person as the proprietor of any land shall not confer any right to minerals or mineral oils thereon or thereunder, but otherwise it shall vest in the person so registered the absolute ownership of that land together with all rights and privileges belonging or appurtenant thereto ; 5

(b) the registration of any person as the proprietor of a lease shall vest in that person the leasehold interest described in the lease together with all rights express and implied and appurtenances attached thereto and subject to all agreements express or implied and all liabilities and incidents of a lease. 10

Cap. 120,  
121.

(2) For the purposes of this section “mineral oils” and “minerals” have the meaning set out in the Mineral Oils Act and the Minerals Act.

Rights of  
proprietor.

40.—(1) The rights of a proprietor, whether acquired on first registration or subsequently for valuable consideration or by an order of a High Court or any superior Court shall be rights not liable to be defeated except as provided in this Act ; and such rights shall be held by the proprietor, together with all privileges and appurtenances belonging thereto, free from all other interests and claims whatsoever, including those of the state, but subject— 15  
20

(a) to any encumbrances and to the conditions and restrictions, if any, shown in the land register ;

(b) unless the contrary is expressed in the land register, to such liabilities, rights and interests as affect the same and are declared by this Act not to require notification on the land register. 25

(2) Nothing in this section shall be construed so as to relieve a proprietor from any duty or obligation to which he is subject as a trustee or family representative under this Act.

Voluntary  
transfer.

41. Every proprietor who by transfer acquires any land or charge without valuable consideration shall hold the land or charge, as the case may be, subject to all unregistered rights and interests affecting the same to which they were subject when in the hands of his transferor, and subject also to the provisions of any law relating to bankruptcy and to the winding up provisions of the Companies Act ; but otherwise any such transfer shall, when registered, have in all respects the same effect as a transfer for valuable consideration. 30  
35

Cap. 37.

Overriding  
interests.

42.—(1) All registered land shall, unless the contrary is expressed in the relevant edition of the land register be subject to such of the following overriding interests as may for the time being subsist and affect the same that is to say— 40

(a) rights of way, rights of water and any easement or profit a prendre subsisting at the time of first registration under this Act ;

(b) rights of entry, search and user conferred by any other Act ;

(c) leases or agreements for leases for any term less than five years where there is actual occupation under the lease or agreement ; 45

(d) any tax or rate for the time being declared by law to be a charge on land or buildings erected thereon ;

(e) rights acquired or in process of being acquired by virtue of any enactment relating to the limitation of actions or by prescription; and

- 5 (f) the rights of every person in possession or actual occupation of the land to which he may be entitled in right of such possession or occupation, save where enquiry is made of such person and the rights are not disclosed.

- (2) The Registrar may in proper case direct registration of any of the liabilities, rights and interests referred to in subsection (1) of this subsection in such manner as he thinks fit; and to the extent to which  
10 registration is so directed, this section shall cease to have effect.

43. Every proprietor shall be deemed to have had notice of every entry in the land register relating to any land, or encumbrance acquired by him.

Entries to give actual notice.

#### PART IV.—CERTIFICATES AND SEARCHES

- 15 44.—(1) The Registrar shall, if requested by the proprietor of any land, issue to him a land certificate in the prescribed form showing all subsisting entries affecting that land. A land certificate when issued shall be prima facie evidence of the particulars set out in the relevant edition of the land register at the date of issue of such certificate, but shall  
20 not obviate the necessity for a search of the land register. Not more than one land certificate shall be issued in respect of each parcel.

Land certificate may be issued.

- (2) Where there are more proprietors than one, the proprietors shall agree among themselves as to who is to receive the land certificate and, if they are unable to agree, the land certificate shall be retained in  
25 the Land Registry.

(3) If a land certificate is issued under this section the date of its issue shall be noted in the relevant edition of the land register.

- 30 45.—(1) Where a land certificate has been prepared and is not retained in the Land Registry, it shall be produced to the Registrar on the registration of any dealing with the land to which it relates, unless the Registrar for sufficient cause dispenses with its production.

Land certificate to be produced with dealings

(2) Upon completion of the registration a note of the dealing shall be made on the land certificate, and if the Registrar thinks fit, the land certificate may be destroyed or be retained in the Land Register.

- 35 46.—(1) If a land certificate is lost or destroyed the proprietor may apply to the Registrar for the issue of a new land certificate and shall produce evidence to satisfy the Registrar of the loss or destruction of the previous land certificate.

Lost or destroyed land certificates.

- (2) The Registrar may require a statutory declaration under the  
40 Oaths Act 1963 that the certificate has been lost or destroyed; and if satisfied with the evidence as to the loss or destruction of the land certificate, and after publication in such manner as he may authorise of notice of intention to do so, the Registrar may issue a new land certificate.

1963 No. 23.

- 45 47.—(1) Any person may apply in writing to the Registrar for leave to inspect any edition of the land register and any sheet of the Land Registry map or any instrument or plan filed in the Land Registry, during the hours of business, and leave may be granted on such conditions as the Registrar thinks fit.

Searches and copies.

(2) Any person may require an official search in respect of any parcel and upon prepayment of the prescribed fee shall be entitled to particulars of the subsisting entries in the edition relating thereto or to obtain a certified copy of any edition or part of the Land Registry map or of any instrument or plan filed in the Land Registry. 5

Registration as evidence of signatures, etc.

48.—(1) Judicial notice shall be taken of the signature of the Registrar, the deputy registrar and every assistant registrar by all courts and persons.

(2) Every copy or extract certified by the Registrar shall in any proceedings be received as prima facie evidence of the original entry in the land register, or of the Land Registry map or of any instrument or plan filed in the Land Registry, and of the matter and transactions therein recorded or registered. 10

(3) Save with the leave of a court, no process for compelling the production of any part of the land register or of the Land Registry map or of any instrument or plan filed in the Land Registry shall issue, and leave shall not be granted where a certified copy or other secondary evidence will suffice ; and if a court issues any such process, the process shall show on its face that it was issued with the leave of the court. 15

PART V.—DISPOSITIONS 20

General

Subsequent dealings.

49.—(1) No land, lease or charge shall be capable of being disposed of except in accordance with the provisions of this Act and every attempt to dispose of such land, lease or charge otherwise, shall be ineffectual to create, extinguish, transfer, vary or affect any estate, right or interest, legal or equitable, in the land, lease or charge. 25

(2) Nothing in this section shall be construed as preventing any unregistered instrument from operating as a contract.

Protection of person dealing in registered land.

50.—(1) No person dealing or proposing to deal for valuable consideration with a proprietor shall be required or be in any way concerned— 30

(a) to enquire or ascertain the circumstances in or the consideration for which such proprietor or any previous proprietor was registered ; or  
 (b) to see to the application of any consideration or any part thereof ; 35  
 or

Cap. 99.  
 Cap. 181.

(c) to search any register kept under the Land Registration Act or the Registration of Titles Act.

(2) Where the proprietor of land or of a lease or a charge is a trustee or a family representative he shall, for the purpose of any registered dealings, be deemed to be the absolute proprietor thereof and no disposition by such trustee or family representative to a bona fide purchaser for valuable consideration shall be defeasible by reason only of the fact that such disposition amounted to a breach of trust or breach of family law or custom. 40

51. If an instrument is presented for registration later than two months from the date of its execution an additional fee equal to the registration fee shall be payable for each two months which have elapsed since its execution; but in no case shall the additional fee payable exceed an amount that is more than five times the original registration fee payable.

Additional  
fee for  
delayed  
registration

52.—(1) Where the Registrar is satisfied that any person, through his own wilful default, has failed to register an instrument, the Registrar may by notice in writing order such person to present the instrument for registration under this Act; and the registration fee shall upon receipt of the notice become due and payable whether or not the instrument is presented for registration.

Power to  
compel  
registration.

(2) Any person who, within one month of the service upon him of a notice under this section fails to comply therewith shall be guilty of an offence and liable on conviction to a fine of twenty pounds.

53.—(1) Interests appearing in an edition of the land register shall have priority according to the order in which the instruments creating them were presented for registration, irrespective of the dates of the instruments; and no person shall be concerned to see that registration is completed on the date of presentation of the relevant instrument.

Priority of  
registered  
interests.

(2) Instruments sent by post or under cover and received during the hours of business shall be deemed to be received simultaneously immediately before the closing of the office for that day; and those received between the time of closing and the next opening of the office for business shall be deemed to be received simultaneously immediately after such next opening.

(3) Where more instruments or applications than one and affecting or relating to the same land, lease or charge are presented on the same day or at so short an interval from each other that in the opinion of the Registrar a question of priority for registration between them arises, the Registrar may refuse registration until he has heard and determined the rights of the parties interested thereunder.

54. Nothing in or purporting to be done under this Act shall affect the provisions of any written law requiring or prescribing the consent of any authority to any dealing with or disposition of any land, lease or charge, and accordingly registration under this Act shall not validate any dealing otherwise invalid by any such written law.

Saving for  
other laws

55.—(1) Where any person proposing to deal with registered land has, with the consent in writing of the proprietor, applied for an official search and has stated in his application the particulars of the proposed dealing, the Registrar shall make an order staying registration of any instrument affecting the land to be comprised in the proposed dealing. An order so made shall stay registration for fourteen days from the time when application for the search was made, and the Registrar shall note the land register accordingly.

Stay of  
registrat

(2) If within the said period of fourteen days a properly executed instrument effecting the proposed dealing is presented for registration, such instrument shall have priority over any other instrument presented for registration after the time of application for the search; and such instrument may be registered notwithstanding any caveat or any other entry made in the land register during the said period, and the stay of registration shall lapse. 5

(3) Subject to the presentation of the instrument duly executed in respect of which the stay of registration was obtained and within the prescribed period, any other instrument and any caveat or application received in the Land Registry during such period, may be dealt with in the same manner, and shall have the same priority and be as effectual as if no stay of registration had been obtained. 10

Merger of registered interests.

56.—(1) Where on the registration of any disposition interests under this section vest in the same proprietor, the interests shall not merge before a surrender or discharge is registered or, as the case may require, the parcels are combined in one title or the titles are endorsed by the Registrar. 15

(2) The interests under this section are any of the following, that is to say— 20

(a) lessor and lessee;

(b) chargor and chargee;

(c) land burdened with an easement, profit a prendre or restrictive covenant, and land which benefits therefrom.

Dispositions by family representatives.

57. Where land is family land a disposition shall not be accepted if it is signed by a number of family representatives less than that appearing in the land register unless— 25

(a) it is executed by all the surviving family representatives; and

(b) it is supported by a statutory declaration under the Oaths Act 1963 made by the surviving family representatives to the effect that they have consulted all adult members of the family in accordance with family custom and that a majority of such adult members is in favour of the disposition. 30

1963 No. 23.

#### Leases

Term of leases.

58.—(1) Subject to the provisions of this or any other Act, the proprietor of land may lease it upon such conditions as he thinks fit to any person for a fixed or determinable term, or for a term which in itself is indefinite but may be determined by the lessor or the lessee by notice under this Act, or by mutual agreement. 35

(2) For the avoidance of doubt, any room or part of a building erected on land may be the subject of a lease and any such disposition shall be registrable accordingly. 40

Periodic tenancies.

59.—(1) Where in any lease the term is not specified and no provision is made for the giving of notice to determine the tenancy, the lease shall be deemed to create a periodic tenancy. 45

(2) Where the proprietor of any land permits the exclusive occupation of the land or any part thereof by any other person at a rent but without any agreement in writing, that occupation shall be deemed to create a periodic tenancy.

(3) For the purposes of this section, the term of a periodic tenancy shall be computed by reference to the date on which rent is payable, but in no case exceeding six calendar months; and accordingly a periodic tenancy may be determined by either party giving to the other notice expiring on the next succeeding day on which rent would, but for the notice, be owing and payable, and by payment of all rent due up to the expiry date of the notice.

60. A lease for a period of five years or more, or which is for a term less than five years but contains an option whereby the lessee can require the lessor to grant him either a further term or further terms which, with the original term, would exceed five years, shall be in the prescribed form. The lease shall be presented for registration in triplicate against the land as an encumbrance, and registration shall be completed by the opening of an edition of the land register in respect of the lease in the name of the lessee and by thereafter retaining one copy of the instrument in the Land Registry.

Registration of leases.

61. When any land is subject to a charge, no lease of such land shall be registered without the previous consent in writing of the proprietor of the charge unless the charge otherwise expressly so provides.

Lease of charged land.

62.—(1) A lease may be made for a term to begin on a future date, not being later than twenty-one years from the date of the lease, but until registered, a lease for any such term shall be of no effect.

Reversionary Leases.

(2) Any instrument purporting to create a lease to begin on a date more than twenty-one years after the date of the instrument shall be void.

63.—(1) Where a person, having lawfully entered into occupation of any land as a lessee, continues to occupy that land with the consent of the lessor after the determination of the lease, the person who so entered shall, in the absence of any evidence to the contrary, be deemed to be a tenant holding the land on a periodic tenancy and, subject to this or any other Act, the conditions of the determined lease, so far as they are appropriate to a periodic tenancy under this Act, shall continue to apply.

Holding over.

(2) For the purposes of this section, the acceptance of rent in respect of any period after the determination of the lease shall, if the former tenant is still in occupation and subject to any agreement to the contrary, be deemed to constitute evidence of consent to the continued occupation of the land.

64. Save as otherwise expressly provided in the lease, there shall be implied in every lease, agreements by the lessor with the lessee binding the lessor—

Agreements implied in leases on the part of the lessor.

(a) that so long as the lessee pays the rent and observes and performs the agreements and conditions contained or implied in the lease and on his part to be observed and performed, the lessee shall and may peaceably and quietly possess and enjoy the land during the term of the lease without any lawful interruption from or by the lessor or any person rightfully claiming through or under him;

(b) that the lessor will not use or permit to be used any adjoining or adjacent land of which he is the proprietor or lessee in any way which would render the land leased unfit or materially less fit for the purpose for which it was leased;

(c) where any flat or room is leased furnished or unfurnished, that he will keep the roof and main walls in repair ;

(d) where any dwelling-house, flat or room is leased furnished, that such dwelling house, flat or room is fit for habitation at the commencement of the tenancy.

5

Agreements implied in leases on the part of the lessee.

65. Save as otherwise expressly provided in the lease, there shall be implied in every lease, agreements by the lessee with the lessor binding the lessee—

(a) to pay the rent reserved by the lease at the times therein mentioned ;

10

(b) during the continuance of the lease, to pay all rates and taxes which may be payable in respect of the land leased not otherwise exclusively payable by the lessor under any written law ;

(c) in the case of agricultural land, to farm the same in accordance with the practice of good husbandry and to yield up the land at the end of the term in good heart ;

15

(d) except where a dwelling-house is leased furnished or a flat or room is leased furnished or unfurnished, to keep all buildings comprised in the lease in repair ;

(e) to permit the lessor or his agent with or without workmen or others at all convenient times and after reasonable notice to enter on the land and examine the state and condition thereof ;

20

(f) to repair or otherwise make good any defect or breach of agreement of which notice shall be given, within such reasonable period as may be specified in the notice.

25

Meaning of "in repair".

66. Where an agreement is contained or implied in any lease to keep any building in repair, the building shall be kept in the same state of repair as that in which an owner might reasonably be expected to keep his property, due allowance being made for the age, character and locality of the building at the commencement of the lease :

30

Provided that there shall not be implied in any such agreement an undertaking to put any building into a better state of repair than that in which it was at the commencement of the lease.

Forfeiture of lease.

67. Subject to the provisions of this Act as to relief against forfeiture and to anything to the contrary in a lease, the lessor thereof shall have the right to forfeit the lease if the lessee commits a breach of any agreement or condition express or implied in the lease ; and the right of forfeiture may be exercised—

35

(a) by entry upon and remaining in possession of the land affected where neither the lessee nor any person claiming through or under him is in occupation of the land ; or

(b) by action in the High Court.

40

Notice before forfeiture.

68. Notwithstanding anything to the contrary contained in any lease, a lessor shall not be entitled to exercise the right of forfeiture for the breach of any express or implied agreement or condition in the lease, until the lessor has served on the lessee a notice—

45

(a) specifying the particular breach complained of ; and

(b) if the breach is capable of remedy, requiring the lessee to remedy the breach within such reasonable period as may be specified in the notice ; and

(c) in any case, requiring the lessee to make compensation in money for the breach, and the lessee fails within a reasonable time thereafter to remedy the breach, if it is capable of remedy and, as the case may be, to make reasonable compensation in money.

5       69.—(1) A lessee upon whom a notice has been served under section sixty-eight of this Act or against whom the lessor is proceeding by action or re-entry to enforce his right of forfeiture, may apply to the High Court for relief, and the High Court having regard to the proceedings and conduct of the parties and the circumstances of the case  
10 may, if it thinks fit, grant or refuse relief; and relief if granted shall be upon such terms as the High Court may impose.

Relief  
against  
forfeiture.

(2) The High Court may, on application by any person claiming any interest in the property comprised in the lease or any part thereof as sublessee or chargee, make an order vesting the property or any  
15 part thereof as the case may require in such sublessee or chargee for the whole of term of the lease or any less term, upon such conditions as the High Court in the circumstances of the case may think fit.

(3) This section shall have effect notwithstanding any stipulation or agreement to the contrary in any lease, whether registered or not.

20 (4) For the purposes of this section a lease limited to continue as long only as the lessee abstains from committing a breach of agreement or condition shall be construed and take effect as a lease to continue for any longer term for which it could subsist, but determinable by a proviso for re-entry on such breach.

25       70. Unless a notice under section sixty-eight of this Act has been served on the lessee, the agreements and conditions contained or implied in any registered lease may be varied negated or added to, and the term of any lease may from time to time be extended by a memorandum executed by the lessor and the lessee for the time being and registered  
30 before the expiration of the then current term of the lease.

Variation  
and  
extension  
of leases.

71. Where a lease is presented for registration and the Registrar is on such evidence as he may require that the lessee is the person named as the proprietor of a prior lease in respect of the same land, he may cancel the registration of the prior lease and register the new lease.

Substitution  
of leases.

(1) Subject to the provisions of his lease, the proprietor thereof if the lease is registered under this Act may sublet for any period less than the remainder of the period of his lease by an instrument in the prescribed form; and unless otherwise expressly provided, the provisions of this Act affecting leases, and parties thereto shall apply to subleases and parties thereto with such adaptations as are necessary.

Subleases.

(2) There shall be implied in every sublease in addition to those provisions of this Act in leases, an agreement by the sublessor that he will, in consideration of the continuance of the sublease pay so much of the rent reserved in the lease as he shall see fit, and observe and perform the agreements and conditions contained in the lease as to the land in the sublease.

(3) If the sublessee has paid to the head lessor of the land any part of the rent payable by his sublessor in respect of the land, the sublessee shall be entitled to set off any sum so paid against any sum payable by him to his sublessor in respect of his sublease.

(4) If a lease is determined by operation of law or by surrender under any law relating to bankruptcy, any sublease of the lease shall also be determined.

Surrender  
of leases.

73.—(1) A lease may be surrendered by an instrument of surrender in the prescribed form or by writing the word "Surrendered" with the date of surrender, on the original or the duplicate of other copy acceptable to the Registrar, and by the execution thereof by the lessor and the lessee. Upon presentation of such document duly executed and payment of the prescribed fee, the registration of the lease shall be cancelled and the interest of the lessee shall cease.

(2) No lease which is subject to a charge or a sublease shall be surrendered without the consent in writing of the proprietor of the charge or sublease.

Determina-  
tion of  
leases.

74.—(1) Where a registered lease has been determined—

(a) by effluxion of time ; or

(b) by the happening of an event upon which the lease is expressed to determine ; or

(c) by lawful re-entry and recovery of possession ;

the lessor may apply in writing to the Registrar to cancel the registration thereof.

(2) An application under this section shall be supported by such evidence of the happening of the event and of the lawful re-entry as the Registrar may require, and if the Registrar is satisfied, he shall cancel the registration of the lease, and the land shall thereupon cease to be subject to the lease.

### Charges

Form and  
effect of  
charges.

75.—(1) The proprietor of any land, lease or charge under this Act may by instrument create a charge thereover to secure the payment of a debt or other money or money's worth or the fulfilment of any condition, and the instrument creating the charge may be registered as an encumbrance ; but until registered, a charge under this Act shall not affect the interest of the proprietor in the land, lease, or charge.

(2) A charge under this section shall not operate as a transfer of the land charged, but shall have effect as a security only.

(3) There may be included in an instrument of charge securing the fulfilment of a condition or the payment of an annuity or other periodical payment not of the nature of interest on a capital sum, such provisions, not inconsistent with this Act, as the parties think fit for disposing of the money which may arise on the exercise by the chargee of his power of sale, either by investing the proceeds of sale or a part thereof to make future periodical payments, or by payment to the chargee of such proceeds or part thereof being the estimated capital value of the chargee's interest, or otherwise.

Second or  
subsequent  
charges.

76. The proprietor of land subject to a charge may create subsequent charges in the same manner as a first charge and the same provisions with all necessary changes shall apply thereto ; but a sale under any power express or implied in any such subsequent charge shall be subject to all prior subsisting charges.

77. Where a charge is created by a company which has its registered office or an established place of business in Nigeria, the charge shall not be registered under the provisions of this Act unless the Registrar is satisfied that the charge has been duly registered under the provisions of the Companies Act within the time therein prescribed or within such extended time as the High Court may allow.

Charges by companies.

Cap. 37.

78. There shall be implied in every charge, unless the contrary is expressed therein, agreements by the chargor with the chargee binding the chargor—

Agreements implies in charges.

(a) to pay the principal money on the day therein appointed and, so long as the principal money or any part thereof remains unpaid, to pay interest thereon or on so much thereof as for the time being remains unpaid at the rate and on the days and in manner therein specified;

(b) to repair and keep in repair all buildings or other improvements upon the charged land and to permit the chargee or his agent, at all reasonable times until such charge is discharged and after reasonable notice to the chargor to enter upon the land and examine the state and condition of such buildings and improvement;

(c) to insure and keep insured all buildings upon the charged land against loss or damage by fire in the joint names of the chargor and chargee with insurers approved by the chargee to the full insurable value thereof;

(d) not to lease the charged land or any part thereof for any period longer than one year without the previous consent in writing of the chargee; and

(e) in the case of a lease, to pay the rent as and when required thereunder and to perform and observe the other agreement and conditions on the part of the lessee to be performed and observed and to keep the chargee indemnified against all proceedings, expenses claims on account of the non-payment of the said rent or any part thereof or the breach or non-observance of the said agreements and conditions, or any of them.

Variation of charges.

79. The amount secured, the rate of interest or the term of the charge may be varied by the registration of a memorandum of variation executed by the parties thereto, but no such variation shall affect the rights of the proprietor of any subsequent charge unless he has consented thereto in writing on the memorandum of variation.

Right of redemption.

80.—(1) Subject to the provisions of this section, if at any time before it has been sold in exercise of the power of sale conferred by this Act, or before the making of a foreclosure order, as the case may be, a chargor pays or tenders payment of all moneys due and owing under the charge at the time of payment or tender of payment or on fulfilment of any condition secured thereby, he shall be entitled to redeem the land charged; and any agreement or provision which purports to deprive the chargor of the right of redemption shall be void.

(2) If the chargor seeks to redeem the land charged before the date specified in the charge, he shall pay to the chargee, in addition to any other money then due or owing under the charge, the principal sum secured thereby for the unexpired period of the term of the charge.

(3) If the chargor seeks to redeem the land charged after the date specified in the charge, he shall give the chargee three months notice in writing of his intention to redeem the charge, or pay him three months interest in lieu thereof.

(4) If at any time the chargor is entitled and desires to repay the money secured by the charge but the chargee for any reason cannot be found, or the Registrar is satisfied that the charge cannot be discharged otherwise, the chargor may pay the amount due into the High Court to the credit of the chargee; and upon application in writing signed by the chargor and production of the receipt for the money paid into that court, the Registrar shall cancel the registration of the charge.

Notice in  
case of  
default.

81. If default is made in payment of the principal sum, or of any interest or other periodical payment or any part thereof, or in the performance or observance of any agreement, express or implied, in any charge and such default continues for one month thereafter, the chargee may serve on the chargor notice in writing requiring him to pay the money owing, or to perform and observe the agreement, as the case may be.

Power of  
sale under  
a charge.

82.—(1) If within three months after the service of a notice of default under this Act the chargor does not comply with it the chargee may, in good faith and having regard to the interests of the chargor, sell or concur with any other person in selling the charged land or any part thereof, together or in lots, by public auction for a sum payable in one amount or by instalments, subject to such reserve price and conditions of sale as the chargee thinks fit, with power to vary or to rescind any contract for sale and to resell by public auction without being answerable for any loss occasioned thereby.

(2) A transfer by a chargee in exercise of his power of sale shall be in the prescribed form, and the Registrar may accept it as sufficient evidence that the power has been duly exercised.

(3) Upon registration of such transfer the interest of the chargor as described therein shall vest in the transferee freed and discharged from all liability on account of such charge, or on account of any charge registered subsequently thereto.

Application  
of purchase  
money.

83. The purchase money received by a chargee who has exercised his power of sale shall, after discharge of any prior encumbrance to which the sale is not made subject, or if the chargees cannot be found, after payment into the High Court of a sum to meet any such prior encumbrances, be applied in the following order, that is to say—

(a) in payment of all costs and expenses properly incurred incidental to the sale or any attempted sale;

(b) in accordance with any express provision in the charge for disposing of such money and, in default of any such provision, in discharge of the money due to the chargee at the date of the sale;

(c) in payment of any subsequent charges in the order of their priority;

and the balance (if any) of the money received shall be paid to the person who, if the land or other interest had not been subject to any charge so paid off under this section and but for the transfer, would have been entitled as the proprietor to give a receipt for the sale.

84.—(1) If within three months after the service of a notice of default under this Act the chargor does not comply with it, the chargee may instead of exercising his power of sale, apply to the Registrar for the appointment of a receiver of the income, rents and profits of the charged property, or any part thereof; and the Registrar shall, on receipt of the application, appoint a fit person to be the receiver accordingly, and shall enter notice of the appointment in the land register.

Appoint-  
ment and  
duties, etc.  
of receiver.

(2) A receiver appointed under this section shall be deemed to be the agent of the chargor for the purposes for which he is appointed; and the chargor shall be solely responsible for the acts or defaults of the receiver, unless the instrument of charge otherwise provides.

(3) A receiver shall have power to demand and recover by action or otherwise, all the income of which he is appointed receiver, in the name of the chargor, and to give effectual receipts for the same; and where a person pays money to a receiver under this subsection he shall not be concerned to enquire into the validity of the appointment of the receiver.

(4) A receiver may be removed upon the application of the chargor or of the chargee, and a new receiver may at any time be appointed by the Registrar after giving both chargor and chargee an opportunity of being heard; and notice of every removal of and new appointment of a receiver shall be entered in the land register.

(5) A receiver shall be entitled to retain out of any money received by him all costs, charges, and expenses incurred by him as receiver and, for his remuneration, a commission at such rate, not exceeding five *per centum* on the gross amount of all moneys received, as may be specified in his appointment. If no rate is specified in the appointment the rate of commission shall be five *per centum* on the gross amount of all moneys received or such other rate as the chargor and chargee agree or, in default of agreement, such rate as the High Court, upon the application of the receiver may allow.

(6) Where insurance money is paid to a receiver, he shall apply it in making good the loss or damage to the property charged and in respect of which the money is received; and subject thereto the receiver shall apply all money received by him in the order following that is to say—

(a) in discharge of all rents, rates, taxes and outgoings whatever affecting the charged property; and

(b) in reduction of all annual sums or other payments, and the interests on all principal moneys, having priority to the charge in right whereof he is receiver; and

(c) in payment of his commission, costs, charges and expenses and of the premiums on fire insurance or other insurance (if any) properly payable under the charge or as prescribed by this Act, and the cost of executing necessary or proper repairs directed in writing by the chargee; and

(d) in payment of the interest accruing due in respect of any principal money secured by the charge; and

(e) in or towards discharge of the money secured by the charge if so directed in writing by the chargee,—

and the balance, if any, of the money received by him shall be paid to the person who, but for the possession of the receiver, would have been entitled to receive the income of which he is appointed receiver, or who is otherwise entitled to the charged property, as the case may be.

Foreclosure.

85.—(1) Where in intended exercise of power of sale, land charged has been twice offered under the provision of this Act for sale by public auction at an interval of not less than six months between the offers, and the amount of the highest bidding was not sufficient to satisfy the money secured by the charge together with the expenses of the sale, the chargee may apply to the High Court for an order for foreclosure.

(2) The High Court shall, upon receipt of an application under subsection (1) of this section, cause notice to be printed once in each of three successive weeks in at least one newspaper published in Lagos or published in Nigeria and circulating in Lagos offering such land for private sale, and appointing a time not less than one month from the date of the first of such advertisements, upon or after which if a sufficient amount has not been obtained by the sale of such land to satisfy the principal and interest secured and all expenses occasioned by such sale and the proceedings, the High Court will issue to the applicant an order for foreclosure.

(3) An order for foreclosure shall be forwarded for registration to the Registrar; and, when entered in the land register the order shall have the effect of vesting in the chargee the land mentioned therein freed and discharged from any interest of the chargor, and from any charge or encumbrance registered subsequent thereto, not being a lease or easement to which the chargee has consented in writing, and the debt secured by the charge shall be extinguished.

No right of entry into possession on default.

86. It is hereby declared that a chargee shall not be entitled to enter into possession of charged land or to receive the rents and profits thereof, by reason only of default made by the chargor in the payment of the principal money or of any interest or of any other periodical payment or of any part thereof, or in the performance or observance of any agreement, express or implied in the charge.

Discharge of charge.

87.—(1) A discharge, wholly or in part, may be made by an instrument in the prescribed form, or the word "Discharged" may be written on the instrument of charge; and when executed by the chargee a discharge may be registered under this Act.

(2) The discharge shall be completed by the cancellation in the land register of the charge, or part thereof as the case may be, and by filing the instrument in the Land Registry.

Satisfaction of charge.

88. Where in respect of any charge the Registrar is satisfied—

(a) that all money due has been paid to the chargee or to his credit, or

(b) that there has occurred the event or circumstances upon which the money secured ceases to be payable, and that no money is owing,

the Registrar shall order the charge to be cancelled in the land register; and thereupon the land, lease or charge affected shall cease to be subject to the charge.

5

10

15

20

25

30

35

40

45

89. Any instrument of charge may provide for a chargee to make further advances or give credit to the chargor on a current or continuing account ; but, unless such provision is noted in the land register, further advances shall not rank in priority to any subsequent charge without the consent in writing of the proprietor of the subsequent charge, and save as provided in this section, the right to tack is abolished.

Tacking and further advances.

90. A chargee shall have no right to consolidate his charge with any other charge unless such right is expressly reserved in the instruments of charge or in one of them and a note thereof is made in the land register against all the charges so consolidated.

Consolidation.

91. A land certificate may be deposited with any person with the intention of creating a lien over the land referred to therein ; but a deposit so made shall have no effect to charge the land until a caveat, in the prescribed form, has been registered.

No lien by deposit only of land certificate.

15

### *Transfers*

92.—(1) A proprietor may transfer his land or lease or charge by an instrument in the prescribed form ; and the transfer shall be completed by registration of the transferee as proprietor of the land, lease or charge, and by filing the instrument in the Land Registry.

Mode of transfer.

20 (2) The transferee of a charge may call upon any person who executed the charge, or any person claiming through him, to execute the transfer for the purpose of acknowledging the amount due under the charge at the date of execution of the transfer.

25 93. No part of the land comprised in any title in the land register shall be transferred unless the proprietor has first subdivided the land and new titles have been opened in respect of each subdivision.

Transfer of part.

94. On the transfer of a lease, unless the contrary is expressed in the transfer, there shall be implied—

Implied covenants, etc., on transfer of lease.

30 (a) on the part of the transferor, an agreement that the rent, agreements and conditions on the part of the lessee to be paid, performed and observed have been so paid, performed and observed up to the date specified in the transfer or, if no such date is specified, the date of the transfer, and to indemnify the transferee in respect thereof ; and

35 (b) on the part of the transferee, an agreement to pay the said rent as from the day following the date specified in the transfer or the date of the transfer, as the case may be, and to perform and observe the said agreements and conditions and to keep the transferor indemnified against all proceedings, claims and expenses on account of the non-payment of the said rent and the breach of any of the said agreements and conditions.

45 95.—(1) Upon the registration of a lease containing an agreement by the lessee that he will not transfer, sub-let, charge or part with possession of the land leased or any part thereof without the written consent of the lessors, the agreement shall be noted in the relevant edition of the land register and no dealing with the lease shall be registered until the consent of the lessor has been produced to the Registrar.

Restriction on transfer, etc., of lease if consent required.

50 (2) Any such agreement shall, notwithstanding any express provision to the contrary, be deemed to be subject to a proviso that the consent of the lessor shall not be arbitrarily or unreasonably withheld.

- Implied covenants, etc., on transfer of charged land. 96. In every transfer of land subject to a charge, there shall be implied an agreement by the transferee with the transferor to pay the interest secured by the charge at the rate and at the times and in the manner therein specified, and to keep the transferor indemnified against the principal money secured by the charge, and from and against all liability in respect of any of the agreements therein contained or implied on the part of the transferor. 5
- Grants of easements. *Easements, Restrictive Covenants and Profits a Prendre*
- 97.—(1) The proprietor of land may, by an instrument in such form as the Registrar may approve, grant an easement thereover to the proprietor or lessee of adjoining or adjacent land for the benefit of that land. 10
- (2) Any proprietor transferring or leasing land may, in the transfer or lease, reserve an easement for the benefit of adjoining or adjacent land retained by him. 15
- (3) The instrument creating the easement shall indicate clearly—
- (a) the nature of the easement, the period for which it is granted and any conditions, limitations and restrictions intended to affect its enjoyment ;
- (b) the land burdened by the easement and, if required by the Registrar, the particular part thereof so burdened ; and 20
- (c) the land which enjoys the benefits of the easement.
- (4) The grant or reservation of the easement shall be completed by its registration in respect of both the land burdened and the land which benefits, and by filing the instrument in the Land Registry. 25
- Restrictive covenants. 98.—(1) Any proprietor entitled to the benefit of a restrictive covenant (not being a covenant made between a lessor and lessee) with respect to the building on or other user of his land may apply to the Registrar to enter notice thereof in the land register ; and the Registrar shall enter notice thereof by reference to the instrument containing the covenant and shall file the notice in the Land Registry. 30
- (2) Unless it is noted in the land register against the title to the land intended to be burdened, the restrictive covenant shall not be binding on the proprietor of such land or any subsequent person acquiring the land. 35
- (3) The fact that a restrictive covenant is noted in the land register shall not operate to validate any defect, and accordingly any such restrictive covenant, if defective, shall have no greater effect than if it had not been so noted.
- Profits a prendre. 99.—(1) The proprietor of land may, by an instrument in such form as the Registrar may approve, grant a profit a prendre (in this Part of this Act unless the context otherwise requires, referred to as a “profit”). 40
- (2) The instrument shall indicate clearly the nature of the profit, its term, and whether it is to be enjoyed—
- (a) in gross, or as appurtenant to other land ; and 45
- (b) by the grantee exclusively, or concurrently with the grantor.
- (3) The grant of a profit shall be completed by its registration as an encumbrance against the land affected and by filing the instrument in the Land Registry.

100.—(1) Upon production of a duly executed release in the prescribed form the registration of any easement, restrictive covenant or profit shall be cancelled and the easement, restrictive covenant or profit shall thereupon cease to have effect.

Release, etc. of easements, restrictive covenants and profits.

5 (2) On the application of any person affected thereby, the Registrar may cancel the registration of any easement, restrictive covenant or profit upon proof to his satisfaction,—

(a) that the period of time for which it was intended to subsist has expired ; or

10 (b) that the event upon which it was intended to determine has occurred ; or

(c) that it has been abandoned.

15 (3) A court on the application of any person interested in land affected by an easement, restrictive covenant or profit may order the extinguishment or modification in whole or in part of any such easement, restrictive covenant or profit on payment by the applicant in any proper case of compensation to persons thereby suffering loss, if the court is satisfied—

20 (a) that by reason of changes in the character of the property or of the neighbourhood or otherwise as the court thinks fit the easement, restrictive covenant or profit is or ought to be deemed obsolete, or that the continued existence of the easement, restrictive covenant or profit would impede the reasonable user of the land for public or private purposes without securing any real benefit to other persons or would, unless modified, so impede such user ; or

25 (b) that the proposed discharge or modification will not adversely affect the persons or persons entitled to the benefit of the easement, restrictive covenant or profit, as the case may be.

#### *Proprietorship and Partition*

30 101.—(1) It is hereby declared that a sole proprietor may transfer land to himself for life with remainder to any other person, or may transfer any land, lease, or charge to himself and to any other person as joint proprietors or proprietors in common.

Registration and proprietorship.

35 (2) No registration shall be made in favour of two or more persons unless it shows whether they are to hold as joint proprietors or proprietors in common ; and if the tenure is as proprietors in common and the shares are not equal, the share of each proprietor shall be expressed in a vulgar fraction with a denominator not greater than twenty.

40 (3) Where there is doubt in any instrument presented for registration, joint proprietorship shall be presumed to have been intended by the parties unless the contrary is therein expressed.

45 102.—(1) If land or any lease or charge is owned jointly, no proprietor thereof shall be entitled to any separate share ; and unless otherwise prescribed by this Act, dispositions may be made only by all the joint proprietors.

Joint proprietors and severance of interest.

(2) On the death of a joint proprietor his interest shall vest in the surviving proprietors jointly, and upon proof, in such a manner as the Registrar may require, of the death of a joint proprietor the land register shall be amended accordingly.

(3) Joint proprietors, not being trustees, may execute an instrument in the prescribed form signifying that they agree to sever their joint proprietorship, and the severance shall be completed by registration of the joint proprietors as proprietors in common in equal shares and filing the instrument in the Land Registry. 5

(4) For the avoidance of doubt, it is declared that a joint proprietor of any land, lease or charge may transfer his interest therein to all the other joint proprietors, but shall not without the consent of all the other joint proprietors, transfer, lease or charge his interest to any other person. 10

Proprietorship in common.

103.—(1) Where land or any lease or charge is owned in common, each proprietor shall be entitled to a separate undivided share in the whole and on the death of such a proprietor his share shall be administered as part of his estate.

(2) No proprietor owning any land, lease or charge in common with any other person or persons shall deal with his undivided share otherwise than in favour of another proprietor in common of the same land, lease or charge without the consent in writing of the remaining proprietors thereof; but any consent required by this subsection shall not be arbitrarily or unreasonably withheld. 15 20

Partition.

104.—(1) An application in such form as the Registrar may approve for the partition of land owned in common may be made,—

(a) by any one or more of the proprietors; or

(b) by any person in whose favour an order for the sale of an undivided share in such land in execution of a decree has been made; and subject to the provisions of this or any other Act prescribing minimum areas or frontages or requiring the consent of any authority to a partition, the land shall be partitioned as agreed by the proprietors in common or, where there is no agreement, as the Registrar may be order direct. 25 30

(2) The partition of land shall be completed in the land register relating thereto by such entries as the Registrar may require and by filing the application together with the agreement or the order, as the case may be, in the Land Registry.

Power for Registrar to order sale.

105.—(1) Where for any reason land to be partitioned is unsuitable to be so dealt with, or the partition would adversely affect the proper use of the land, the Registrar shall, upon request in writing by any person claiming a registered interest and in default of agreement between the proprietors in common, value the land and the shares of the proprietors in common, and the Registrar may give effect to the request by ordering the sale of the land or the separation and sale of such shares by public auction or, as the case may require, may make such other order as he thinks fit. 35 40

(2) Any proprietor in common shall be entitled to purchase the land or any share or shares offered for sale under this section, either at the auction or by private treaty before the auction. 45

5 106.—(1) When land sought to be partitioned may be partitioned, but the share of any particular proprietor in common is or would be less in area than the minimum prescribed by any Act, the Registrar may add such share to the share of any other proprietor, or distribute such share amongst two or more other proprietors in such manner and in such proportions as, in default of agreement, he thinks fit.

Procedure where share is small.

10 (2) The Registrar shall assess the value of any share to be dealt with under the foregoing subsection, and thereafter may direct payment to the proprietor of such share by every proprietor receiving an addition to his share, of the value of such addition.

15 (3) An appeal to the High Court shall lie from any assessment and direction by the Registrar under this section, and subject thereto, the amount payable may by order of the Registrar, be secured by way of charge on the share of the person or persons liable to pay the value of the share affected.

*Testamentary Dispositions, etc.*

20 107. Nothing in this Act shall be construed to abridge or limit the right of any proprietor, other than a joint proprietor, under the law relating to testamentary dispositions to make a will disposing of his land, lease or charge on his death, or to affect the law of intestate succession.

Testamentary dispositions, etc., not affected.

PART VI.—INSTRUMENTS AND AGENTS

25 108.—(1) Dealings with any land, lease or charge under this Act shall be effected by instruments in the prescribed forms as printed for and issued by the Registrar or as the Registrar in any particular case may approve; and leases and charges shall when executed be presented for registration in triplicate.

Form of instruments.

30 (2) Every instrument shall, according to its nature, contain a true statement of the purchase price, or loan or other consideration; and the statement shall set out how much, if any of the purchase price, loan or other consideration has been paid or received, as the case may be.

109.—(1) Every instrument shall be executed by all parties thereto unless the Registrar dispenses with execution by any particular party as unnecessary in any particular case.

Execution of instruments

(2) An instrument shall be deemed to have been executed—

35 (a) if signed by a natural person;

(b) if sealed with the common seal of a corporation affixed in the presence of and attested by its clerk, secretary or other permanent officer and by a member of the board of directors, council or other governing body of the corporation;

40 (c) in the case of a corporation not required by law to have a common seal, if signed by such persons as may be authorised in that behalf by any law or by the statute of the corporation or, in the absence of any express provision, by two or more persons duly appointed for that purpose by the corporation.

Proof of  
execution.

110.—(1) Unless the Registrar under the powers conferred by this section dispenses with verification, the parties executing an instrument shall appear before the Registrar or such other person as he may require or approve and, if they are unknown to the Registrar or other person as aforesaid they shall be accompanied by a credible witness or credible witnesses as the case may require for the purpose of establishing identity. 5

(2) The Registrar or other person before whom any party appears shall satisfy himself as to the identity of the party so appearing before him; and after ascertaining that such party has freely and voluntarily executed the instrument, the Registrar or such other person, as the case may be, shall prepare and sign a certificate to that effect. Any such certificate may be endorsed on or attached to the instrument to which it relates. 10

(3) The Registrar may dispense with verification under this section— 15

(a) if he considers that it cannot be obtained or can only be obtained with difficulty and he is satisfied by other sufficient evidence that the instrument has been properly executed; or

(b) if to his knowledge the instrument has been properly executed; and where the Registrar dispenses with verification he shall not on the instrument his reasons for dispensing with the appearance of the parties. 20

(4) No instrument executed out of Nigeria shall be registered unless it has endorsed thereon or attached thereto a certificate that it has been signed in the presence of a judge, magistrate, justice of the peace, notary public, or any consul, Nigerian or foreign, as the case may be. 25

Instruments  
to be  
stamped.  
Cap. 191.

111. No instrument liable for stamping shall be presented for registration or be registered unless it is duly stamped under the Stamp Duties Act or, as the case may require, it is endorsed as exempt from such duty by a commissioner under that Act. 30

Disposal  
of  
instruments.

112.—(1) Subject to the provisions of subsection (2) of this section, all instruments accepted by the Registrar shall be retained in the Land Registry for as long as they support a current entry in the relevant land register.

(2) Where the instrument registered is a lease or charge, particulars of the registration shall be noted on the duplicate and triplicate thereof, and they shall be returned to the person who presented them. 35

(3) Five years after an entry in the land register has been superseded or has ceased to have any effect, the Registrar may destroy the instrument which supported the entry. 40

Minors and  
registered  
land.

113. It is hereby declared that the name of a person under the age of twenty-one years may appear in the land register on first registration or as a transferee or on transmission; but the fact that the name of any such person appears in the land register shall not be construed so as to authorise or permit any dealing with the land or any interest in land by such person during his minority, and if to the knowledge of the Registrar a minor is so registered, the Registrar shall enter a caveat accordingly. 45

114.—(1) Save as provided in subsection (3) of this section, no instrument executed by any person as agent for any other person shall be accepted by the Registrar unless the person signing it was authorized in that behalf by a power of attorney executed and verified in the manner prescribed for instruments by this Part of this Act.

Agents for persons under disability.

(2) If an instrument is executed on behalf of some person by his attorney the original or, with the consent of the Registrar, an authenticated copy of the power of attorney shall be filed in the Land Registry.

(3) Where any person who, if not under disability, might have made any application, done any act or been party to any proceeding under this Act is a minor, a person of unsound mind or under any other disability, the guardian of such person, or, if there is no such guardian, then a person appointed in accordance with the provisions of any written law to represent such person, may make any application, do any act, and be party to any proceeding on behalf of any such person and shall generally represent any such person for the purposes of this Act.

(4) An instrument purporting to be signed on behalf of a person under disability shall not be accepted for registration unless the Registrar is satisfied that the person claiming to be the guardian is so entitled ; and where he is not satisfied the Registrar may require production of sufficient evidence of the appointment of the person to act on behalf of the person under disability.

115.—(1) Where a power of attorney contains authority to deal with any land, lease or charge, the power of attorney shall be in the prescribed form and shall, upon the joint application of the donor and donee be filed in the Land Registry.

Power of Attorney.

(2) The donor of a power of attorney filed under this section may at any time give notice to the Registrar in the prescribed form of the revocation thereof ; and after noting the power of attorney, the Registrar shall file the notice in the Land Registry.

(3) Any interested person may in writing notify the Registrar that a power of attorney filed under this section has been revoked by the death, bankruptcy or disability of the donor or by the death or disability for any reason of the donee ; and subject to the production to the Registrar of such evidence as he may require, the Registrar shall note the power of attorney accordingly and file the notice in the Land Registry.

(4) Nothing in subsections (2) and (3) of this section shall apply to a power of attorney given for value and expressed to be irrevocable,

(5) A power of attorney, which has been filed under this section and of which no notice of revocation has been given under this section shall be deemed to be still subsisting ; and no disposition in purported exercise of the powers therein contained shall be defeasible by reason only that the power has been revoked, unless the person for the time being claiming under such disposition had actual notice of such revocation.

PART VII—TRANSMISSIONS, TRUSTS AND FAMILY REPRESENTATION

Transmission on death.

116.—(1) Subject to the provision of this section where a joint proprietor of any land, lease or charge dies, the Registrar shall delete the name of the deceased proprietor from the land register ; and in the case of the death of any other proprietor his legal personal representative shall be entitled to be registered by transmission to the interest of the deceased proprietor.

5

(2) If the application is to delete the name of a joint proprietor, the applicant shall produce to the Registrar satisfactory evidence of such death.

10

(3) If the application is for registration as proprietor by transmission, the applicant shall apply on the prescribed form and produce therewith an office copy of probate of the will or letters of administration in the estate of the deceased proprietor, as the case may be ; and the Registrar if satisfied, shall register the applicant in place of the deceased and shall add thereafter the words "as executor" or "as administrator" with such reference to the will or to the estate as the case may require and may, if he thinks it necessary, enter a caveat to protect the interests of beneficiaries.

15

Registration by personal representatives not on land register.

117. Notwithstanding the provisions of section one hundred and sixteen of this Act the Registrar, upon production to him of probate or letters of administration and without requiring registration of the executor or administrator by transmission may, if he thinks fit,—

20

(a) register any transfer by the executor or administrator in pursuance of the will or by way of distribution under intestacy or in pursuance of an agreement between the persons entitled thereto or of a contract entered into by the proprietor in his lifetime ; or

25

(b) register any discharge of a charge of which the deceased person was the proprietor ; or

(c) register any surrender of a lease of which the deceased person was the proprietor.

30

Applications for registration on death of proprietor, etc

118.—(1) If the executor or administrator of a deceased proprietor fails or neglects to transfer any land, lease, or charge to the persons entitled thereto, or if such land, lease or charge is not for any reason registered in the name of the person entitled thereto, such person or any judgment creditor of such person or any person claiming an interest in such land, lease or charge may, at any time after the expiration of one year from the date of the grant of probate or letters of administration, apply to the Registrar for registration by transmission of the land, lease or charge in the name of the person entitled thereto.

35

40

(2) If application is made to the Registrar under this section, he may, if satisfied that the executor or administrator has had notice of the application and that the estate has been fully administered, allow the application ; and the person entitled thereunder shall be registered accordingly.

45

Effect of transmission by death.

119. Where pursuant to a will or upon intestacy, any land, lease, or charge is registered in the name of or is acquired by the heir, beneficiary, executor, or administrator of a deceased proprietor, as the case may be, the person registered shall, for the purpose of any dealing with such land,

5 lease, or charge be deemed to have acquired it for valuable consideration, and the land, lease or charge may be dealt with accordingly; but until so dealt with the land, lease or charge shall be subject to all unregistered liabilities, rights, or interests affecting the title of, or created or imposed under the will of, the deceased proprietor.

10 120.—(1) A trustee in bankruptcy shall, upon application to the Registrar in the prescribed form accompanied by a certified copy of the order of court adjudging a proprietor bankrupt, or directing that the estate of a deceased proprietor be administered according to the law of bankruptcy, be registered as proprietor of any land, lease or charge in place of the bankrupt or deceased proprietor as the case may be and the entry to be made in the land register shall describe the trustee in bankruptcy as trustee of the property of (*name of proprietor*), a bankrupt. Effect of transmission on bankruptcy.

15 (2) The provisions of section one hundred and nineteen of this Act shall apply to any trustee in bankruptcy as they apply to persons therein set out, but the doctrine of relation back shall have effect according to the laws of bankruptcy or the order of the court as the case may be, and not according to this Act.

20 121. Where the proprietor of any land, lease or charge is a company being wound up and the liquidator produces to the Registrar a certified copy of the resolution or order appointing him liquidator, together with an application in the prescribed form to have notice of the appointment entered in the appropriate land register the Registrar shall, if satisfied, enter notice thereof accordingly; and when so entered, the liquidator shall have the powers of disposition conferred on him by such resolution or order or by any written law in respect of any such land, lease or charge. Effect of notice of liquidation.

25 122. Where the state or any person is entitled to any registered land under the provisions of any Act, or by virtue of any order or writ of execution, the Registrar shall, on the receipt of notice thereof in such form as he may require, register the state or such person as the proprietor thereof. Registration of transmission by expropriation, etc.

30 123.—(1) Any person who acquires any land, lease or charge in a fiduciary capacity may be described by that capacity in the instrument of acquisition and be registered with the addition of the words "as trustee"; but otherwise particulars of any trust shall not be entered in the land register, and the fact that a person is registered as trustee shall not be construed as notice of, or require any person to enquire into particulars of, the trust. Trust not to be entered on land register.

35 (2) Any instrument or certified copy thereof declaring a trust may be deposited with the Registrar for safe custody; but such instrument or copy when deposited shall not form part of the land register.

40 (3) Where the proprietor of land or of any lease or charge is a trustee, he shall hold the same subject to any unregistered liabilities, rights or interests to which the land, lease or charge is liable by virtue of the instrument creating the trust; but for the purpose of registration of any dealings, he shall be deemed to be the absolute proprietor thereof.

45 124. If two or more proprietors are entitled to be or are registered jointly as administrators or executors of a deceased person or otherwise as trustees, and the survivor of such proprietors would not be entitled to exercise alone the powers vested in them, the Registrar shall, upon request in writing or of his own motion, enter the words "no survivorship" in the appropriate land register. Trustees with no survivorship.

Appointment of family representatives.

125.—(1) Where the name of a family has been registered in respect of any land but no family representatives have been appointed, the family may, at any time, hold a family meeting for the purpose of appointing not more than twenty persons to represent the family ; and upon application in writing to him in that behalf accompanied by a list of names of the persons so appointed, the Registrar shall, if he is satisfied that such meeting was after due notice properly held, enter the names in the land register.

5

(2) If the registration of a disposition or transmission would result in the entry in the land register of more than twenty persons as proprietors of any land, lease or charge, the Registrar shall refuse the application unless partition is sought, and require the family to appoint representatives in the manner prescribed by this Act.

10

Removal and replacement of family representatives.

126.—(1) The Registrar, on proof to his satisfaction of the death of a family representative, shall delete the name of such representative from the land register.

15

(2) The Registrar on the application of any member of the family and after giving the remaining family representatives an opportunity of being heard, may delete from the land register the name of any family representative if he is satisfied that such family representative is by reason of mental or physical incapacity, absence or imprisonment, unable to act.

20

(3) If a family representative notifies the Registrar in writing that he no longer wishes to act as a family representative the Registrar shall delete his name from the land register and inform the remaining family representatives of the fact.

25

(4) Upon application in writing by a member of the family, the Registrar after such enquiries as he thinks fit, may amend the land register to add names to the list of family representatives but so as not to increase their number to more than twenty.

30

(5) The High Court, may at any time, on the application of a member of the family order the name of any family representative to be deleted from the land register, and the Registrar shall, upon receipt of a certified copy of the order, delete the name off accordingly.

35

(6) Notwithstanding the deletion from the land register of the names of any family representatives, while two or more family representatives remain thereon, they shall have all the powers of family representatives appointed under this Act ; but nothing in this subsection shall be construed to prohibit a sole representative when duly appointed from exercising the powers of family representative under this Act.

40

Effect of registration of family representatives.

127.—(1) Subject to any caveat entered in the land register, the family representatives shall, when registered, have the exclusive right of dealing with the family land, or with any lease or charge.

(2) Nothing in this Act shall relieve any person registered as the family representative from any duty, customary or otherwise, to consult other members of the family, and a person so registered shall be bound to exercise the powers vested in him by this Act on behalf and for the collective interest of the family ; but any person dealing with him in good faith and for valuable consideration shall not be concerned to

45

inquire whether the family representative has complied with this subsection, and any such failure by the family representative shall not confer any right to indemnity under this Act.

PART VIII.—JUDGMENTS AND WRITS OF EXECUTION

- 5       **128.**—(1) Where a court issues a judgment or writ of execution affecting any land, lease or charge, a certified copy of the judgment or writ, as the case may be, shall be sent by the registrar of the court to the Registrar under this Act with particulars of the land, lease or charge affected thereby for registration against such land, lease or charge ; but  
10 no judgment or writ of execution shall bind or affect the land, lease or charge, until it is registered.
- 129.** While any judgment or writ of execution continues to be registered against any land, lease or charge, the Registrar shall not accept  
15 for registration any instrument in respect of such land, lease or charge, which is inconsistent therewith.
- 130.** Registration of a judgment or writ of execution shall be cancelled,—
- (a) at the request in writing of the judgment creditor or other person for whose benefit the judgment or writ of execution was  
20 issued ; or
- (b) on proof to the satisfaction of the Registrar that the judgment or writ of execution has been satisfied, or has lapsed in accordance with any Act or rules of court for the time being in force.
- 25       **131.**—(1) Where under the provisions of section fifty of the Sheriffs and Civil Process Act a court within the meaning of that Act has granted a certificate on absolute sale to the person declared to be the purchaser of immovable property which is subject to this Act, that section shall have effect as if there were added after the word “interest” where it  
30 secondly occurs, the words “when duly registered under the Registered Land Act 1964” ; and the said section shall, for the purposes only of this subsection, be deemed to be so amended accordingly.
- (2) The sheriff or other person authorised by him shall deduct from the proceeds of the sale the registration fee for the certificate to which the foregoing subsection relates ; and shall forward such registration  
35 fee together with the certificate to the Registrar. Upon receipt thereof and the payment of stamp duty (if any), the Registrar shall enter in the relative land register the name of the person described in the certificate as purchaser of the land, lease or charge, as the case may be, and thereafter the Registrar shall file the certificate.

Power to register judgments, etc.

Effect of registration of judgment, etc.

Cancellation of registration of judgment, etc.

Sale in execution. Cap. 189.

PART IX.—CAVEATS, ETC.

- 40       **132.**—(1) Any person claiming an unregistered right or interest in, or to have presented a bankruptcy petition against the proprietor of, any registered land, lease or charge, may lodge with the Registrar a caveat in the prescribed form ; and when entered in the land register, no  
45 disposition of the land, lease or charge shall, save to the extent to which the caveat may permit or allow, be registered or any entry affecting the same made, until notice under this Act has been served on the caveator, and the caveat has lapsed or the caveator consents in writing to the registration.

Caveats generally.

1963, No. 23.

(2) A caveat shall set out briefly the right or interest claimed by the person lodging it ; and the Registrar may require such person to support the claim by a statutory declaration under the Oaths Act 1963. Where he thinks it unnecessary or its purpose can be effected by the registration of an instrument under this Act he may reject the caveat ; or if he is satisfied it was lodged to protect monetary advances, he may accept it if the circumstances of the case render it expedient to do so.

(3) The Registrar shall give notice in writing of any caveat to the proprietor whose land, lease or charge is affected thereby.

(4) So long as any caveat is subsisting in the land register, no registration inconsistent with the terms of the caveat shall be effected relating to the land, lease or charge affected thereby except with the consent of the caveator or by order of a court of competent jurisdiction.

(5) A caveat may be removed from the land register with the consent of the caveator or by an order of the Court, or by the Registrar under the next succeeding subsection.

(6) The Registrar may, on the application of any person interested together with the presentation of a registrable instrument, serve notice on the caveator warning him that his caveat will be removed at the expiration of the time stated in the notice ; and at the expiration of the time stated, unless the caveator objects, the caveat shall lapse and the Registrar may remove the caveat from the land register. If the caveator objects to the removal of his caveat he shall notify the Registrar in writing of his objection within the time specified in the notice and the Registrar, after giving the parties an opportunity of being heard, shall make such order as to its removal or otherwise and as to costs as he thinks fit.

(7) A caveat entered by the Registrar under the powers conferred upon him by this Act shall be removable only with his consent, or by order of a court.

(8) Where a caveat has lapsed or been withdrawn under this section, the Registrar may refuse to accept a further caveat by the same person or anyone on his behalf in relation to the same matter as that protected by the previous caveat.

Other prohibitions on registration.

133.—(1) For the prevention of fraud or improper dealing or other sufficient cause a court may, on the application of any interested person in its discretion prohibit or restrict the disposition of any land, lease or charge. Any order so made, may be registered against the appropriate land register and, while it continues to be registered, shall have effect according to its tenor.

(2) The Registrar on the application by any person claiming to be interested or of his own motion and after hearing any person desirous of being heard and making such enquiries as he thinks fit, may direct the entry of a caveat against the land register, or any interest therein, as the case may be.

(3) The Registrar may enter a caveat in the land register if it appears to him there is any limitation or restriction on the power of the proprietor to deal with land, or any lease or charge.

(4) Upon the entry of a caveat the Registrar shall give notice thereof to the proprietor affected thereby.

(5) So long as any caveat is subsisting in the land register, any registration against the land, lease or change therein inconsistent with the terms of the caveat shall not be made without an order of court.

5 (6) The Registrar at any time upon the application of any person interested or of his own motion, and after giving the parties affected thereby an opportunity of being heard, may order the removal or variation of any caveat entered by him under this section.

10 (7) Upon the application of any proprietor affected by a caveat under this section, and upon notice thereof to the Registrar, the High Court may order the caveat to be removed or varied, or the court make such other order, including an order as to costs, as it thinks fit.

#### PART X—ADVERSE POSSESSION AND PRESCRIPTION

134.—(1) Ownership of land may be acquired by peaceable, overt and uninterrupted adverse possession thereof—

Acquisition of land by adverse possession.

15 (a) against the state for a period of twenty years ; and

(b) in any other case for a period of twelve years.

20 (2) Any person claiming to have acquired land by virtue of the provisions of subsection (1) of this section may, after having advertised or given notice in such manner as the Registrar may direct, apply to the High Court for an order requiring him to be registered as the proprietor thereof.

25 135.—(1) Where it is shown that a person has been in possession of land or in receipt of the rents or profits thereof at a certain date, and such person is still in possession or receipt thereof, it shall be presumed that he has from that date, as to the land or the rents or profits as the case may be, been in continuous possession or receipt thereof until the contrary is shown.

Principles of possession.

30 (2) Possession of land or receipt of the rents or profits thereof by any person through whom a claimant derives title shall be deemed to have been possession or receipt of the rents or profits by the claimant.

(3) Where from the relationship of the parties or any other special cause it appears that the person in possession of land is or was in possession on behalf of another, his possession shall be deemed to be or to have been the possession of that other.

35 (4) If a person, whose possession of land is subject to conditions imposed by or on behalf of the proprietor, continues in such possession after the expiry of the term during which such conditions subsist without fulfilment or compliance with them by such person and without any exercise by the proprietor of his right to the land, such subsequent possession shall be deemed to be peaceable, overt and uninterrupted adverse possession, available for the purposes of this Act ; and in the application of this subsection—

40 (a) a tenancy at will shall be deemed to have determined at the expiration of a period of one year from the commencement thereof unless it has previously been determined, and

45 (b) a tenancy from year to year or other period shall be deemed to have determined at the expiration of the first year or other period, but where any rent is subsequently paid in respect of the tenancy, it shall be deemed to have determined at the expiration of the period  
50 for which the rent has been paid.

(5) Where at any time during the period prescribed by this Part of this Act, the true owner is under any legal disability, the period of such disability shall not be counted unless a court upon application made to it by the claimant or the owner or other person interested, otherwise directs; and for the purposes of this subsection and the giving of a direction the court shall have power to hear and dispose of the case by motion of which notice has been given under rules of court.

(6) Possession of land shall be interrupted—

(a) by physical entry thereon by any person claiming it in opposition to the person in possession with the intention of causing interruption and the possessor thereby loses possession; or

(b) by the institution of legal proceedings by the proprietor to assert his right thereto; or

(c) by any acknowledgment admitting the claim made by the person in possession to any person claiming to be the proprietor thereof.

(7) A person holding land in a fiduciary capacity shall not acquire title to the land by adverse occupation against the beneficial owner thereof.

Acquisition of easements, etc. by prescription.

136.—(1) Subject to the provisions of the next succeeding subsection, easements and profits a prendre may be acquired without registration by peaceable, overt and uninterrupted enjoyment thereof, if the land adversely affected thereby is state land, for a period of twenty years, and in any other case by such enjoyment for a period of twelve years.

(2) An easement or profit a prendre shall not be acquired by reason of enjoyment under the foregoing subsection unless the proprietor of the land burdened by such easement or profit a prendre knows or ought to have known of the enjoyment and might have prevented it by his own act.

(3) Any person claiming to have acquired any easement or profit a prendre by prescription under this section may, after notice thereof given in such manner as the Registrar may direct, apply to the High Court for an order directing entry of a record of the easement or profit a prendre, as the case may be, in the land register.

This Part not to apply to registered land.

137 After land becomes subject to this Act, no title thereto by adverse possession shall be acquired, and no easement or profit a prendre thereover shall be acquired by prescription; and this Part of this Act shall cease to have effect as to any such land accordingly.

PART XI—REGISTERED LAND ASSURANCE FUND AND RECTIFICATION OF LAND REGISTER

Assurance Fund.

132.—(1) There shall be established a fund to be called the Registered Land Assurance Fund (in this Act referred to as "the Assurance Fund") into which shall be paid all moneys collected under this Part of this Act; and subject to the provisions of this section, moneys in the fund shall be available for the payment of claims under this Act.

(2) No claim shall be admitted or allowed by the Registrar unless the claimant satisfies the Registrar that he has exhausted all rights of action against his predecessor in ownership before making a claim under this Part of this Act, and the claim is thereafter certified for payment by the Registrar and approved by the Minister. Where the amount is in dispute, a court may direct the claim to be so certified by the Registrar.

(3) Moneys in the Assurance Fund shall, for the purpose of control and management, be deemed to be part of the public funds of Nigeria, and subject to the provisions of the Finance (Control and Management) Act 1958 ; and accordingly that Act shall apply save that interest earned shall accrue to the Assurance Fund and not form part of the Consolidated Revenue Fund.

No. 33 of 1958.

139.—(1) There shall be paid to the Registrar on the first registration after land is brought under the provisions of this Act, in addition to any registration fee such amount as may be prescribed, not exceeding in any case a rate of one halfpenny in the pound on the value of the land with all improvements existing thereon when so brought under this Act ; and the Registrar may accept a certificate by the proprietor of the value for such purpose, or require a valuation to be made by a competent valuer.

Payment to Assurance Fund on first registration.

(2) Moneys so collected which are additional to the registration fees, shall be paid by the Registrar into the Assurance Fund.

(3) Any certificate given under this section shall be deemed to be a declaration as to value, and shall be construed and have effect accordingly.

140.—(1) The Registrar may at any time with the consent of all persons interested, rectify entries in the land register ; and of his own motion may amend the land register, or correct errors or supply omissions therein where they do not materially affect the interests of the proprietor, or where they relate to matters of form only.

Rectification by Registrar.

(2) Upon proof of the change of the name or address of any proprietor the Registrar shall, on the application in writing of the proprietor, amend the land register accordingly.

141.—(1) Subject to the provisions of subsection (2) of this section a court may in any of the following cases order cancellation or amendment of a land register—

Rectification by court.

(a) where by mistake two or more persons have been registered as proprietors of the same land, lease or charge ;

(b) where the court is satisfied that any registration (other than registration made pursuant to an adjudication record under this Act) has been obtained, made or omitted by fraud or mistake ;

(c) where it is necessary to supply any material omission ;

(d) where any person appears from the record to have acquired land or an interest in land by prescription under Part X of this Act ; and upon production of a certified copy of the order and payment of the prescribed fee, the Registrar shall amend the land register accordingly.

(2) An entry in the land register shall not be cancelled or amended so as to affect adversely the title of a proprietor who is in possession unless such proprietor is a party or privy to the omission, fraud or mistake in consequence of which cancellation or amendment is sought, or has caused such omission, fraud or mistake or substantially contributed thereto by his act, neglect or default.

142.—(1) Subject to the provisions of this Act, any person suffering loss by reason of—

Right to indemnity.

(a) any rectification of the land register under this Act other than in the case of acquisition by adverse possession or by prescription ; or

(b) any mistake or omission in the land register which cannot be rectified under this Act, and the mistake or omission is one not arising in a first registration out of an adjudication record under this Act ;

(c) any error in a copy of or extract from the land register or from any instrument or plan certified under the provisions of this Act ;

may claim against the Assurance Fund in proper case, and if there are insufficient moneys in the Assurance Fund, the Federal Minister of Finance upon application made by the Registrar and approved by the Minister may, if satisfied, authorise payment out of the Contingencies Fund subject to such conditions as he may prescribe.

Cf. 1958 No.  
33

(2) No indemnity shall be payable under this Act to any person who has himself caused or substantially contributed to the loss by his fraud or negligence, or who derives title (otherwise than under a registered disposition for value) from a person who so caused or substantially contributed to the loss.

Costs, etc.,  
on any claim

143. The Registrar when considering any claim against the Assurance Fund may take into account any costs and expenses properly incurred.

Restriction  
on claims in  
respect of  
surveys.

144.—(1) Where the boundaries of any registered land are defined without sufficient survey or by reference only to any survey of adjacent land and the land register is noted as limited as to parcels or to the like effect, no claim shall lie against the Assurance Fund in respect of any alteration in area by reason of the survey of such land made at any time thereafter.

(2) As between the state and a proprietor, no claim to compensation shall arise and no suit shall be maintainable on account of any surplus or deficiency in the area of any land disclosed by a survey forming the basis of the title and any subsequent survey of that land.

(3) As between a proprietor and any person from or through whom he acquired the land, no claim to compensation shall be maintainable on account of any surplus or deficiency in the area thereof disclosed by a survey showing a different area from that in any other survey, or from the area shown in the land register after a period of six months from the date of registration of the instrument under which the proprietor acquired the land.

Amount of  
indemnity.

145. Where a claim is allowed against the Assurance Fund in respect of the loss of land or any interest in land and there is no rectification of the land register, the amount paid shall not exceed the value of the land or interest at the time when the mistake or omission which caused the loss was made ; and in any other case, the amount paid shall not exceed the value of the land or interest immediately before the time of rectification.

Power to  
enforce  
covenant  
where  
indemnity  
paid.

146. If indemnity is paid under this Part of this Act, the Minister may if he thinks fit, enforce any express or implied covenant or other right which the person who is indemnified would have been entitled to enforce in relation to the matter in respect of which the indemnity has been paid.

## PART XII—DECISIONS OF REGISTRAR AND APPEALS

147. If any question arises with regard to the performance of any duty or the exercise of any functions by this Act conferred or imposed on him, the Registrar may state a case for the opinion of the High Court; and when given, the opinion shall be binding upon the Registrar.

Power for Registrar to state a case.

148.—(1) Any person aggrieved by a decision or order of the Registrar, may, within one month from the date of the decision or order, give notice to the Registrar in the prescribed form of his intention to appeal to the High Court against such decision or order.

Appeal against decision of Registrar.

(2) On receipt of a notice of appeal, the Registrar shall prepare and send to the High Court and to the appellant, and any other person appearing by the land register to be affected by the appeal, a brief statement of the question in issue.

(3) The High Court after hearing all interested parties may make such order on the appeal as the circumstances may require, and any order made shall if there is no further appeal, be binding on the Registrar.

(4) An appeal shall lie from an order of the High Court to the Supreme Court and shall be made within such time as rules of court may prescribe in the case of appeals relating to land in civil cases, as nearly as may be.

(5) The costs of the appeal shall be in the discretion of the court making the order or disposing of the appeal as the case may be.

149.—(1) If an appeal to a court is pending the Registrar shall note the land register affected; and save as otherwise provided in this section, any disposition shall have effect subject to the outcome thereof.

Effect of notice of appeal on disposition.

(2) An appeal to a court shall not affect a disposition for valuable consideration registered before delivery of notice of the appeal to the Registrar.

(3) This section shall apply to an appeal from an order of a High Court to the Supreme Court as it applies to an appeal to the High Court.

150.—(1) The Chief Justice of Lagos may make rules prescribing the procedure to be followed in the conduct of appeals from decisions of the Registrar to the High Court of Lagos.

Power to make rules of court.

(2) The Chief Justice of Nigeria may, for the purposes of this Part, make rules prescribing the procedure to be followed in the conduct of appeal from the High Court.

## PART XIII.—MISCELLANEOUS AND TRANSITIONAL

151.—(1) No instrument intended for registration shall be accepted under this Act, unless it is in the prescribed form or is in such other form as the Registrar may approve.

Certification of documents.

(2) Every such instrument shall have endorsed thereon a certificate to the effect that it is correct for the purposes of the Registered Land Act, and such certificate shall be signed by the party claiming interest thereunder or by his solicitor; and no instrument shall be accepted for registration if the certificate is not so signed. The making of any false certificate for the purposes of this Act shall be an offence for which the offender shall be liable on summary conviction to a fine of fifty pounds, and the court convicting may direct the removal from the land register of the instrument, if registered.

- Registration fees. 152.—(1) There shall be paid upon the first registration made after the bringing of land under this Act such fees in respect of the dealing therewith, additional to the contribution to the Assurance Fund under section one hundred and thirty-nine of this Act, as may be prescribed by regulations for registration of instruments under this Act. 5
- (2) There shall be paid in respect of every instrument thereafter presented for registration or otherwise to be dealt with by the Registrar, such fees as may be prescribed by regulations under this Act.
- (3) No instrument shall be accepted for registration or be deposited or filed after the preparation of the land register in respect of land subject to this Act, until the fees so prescribed for the instrument have been paid. 10
- Addresses of caveators and others to be given to Registrar. 153. Any person who, under the provisions of this Act, submits a caveat or any instrument for registration, or appears on the land register as the proprietor of any land, lease or charge shall, if required, give to the Registrar in writing a postal address for service within the Federal territory, and shall give notice in writing to the Registrar of any subsequent change in the address. 15
- Services of notices. 154. A notice under this Act shall be deemed to have been served on or given to any person— 20
- (a) if it is served on him personally ; or
- (b) if it is left for him at his last known address ; or
- (c) if it is sent by registered post to him at his last known address.
- Hearings and opportunity of being heard. 155.—(1) Where a thing may be done after a hearing or after giving a person an opportunity of being heard before the Registrar, it shall be sufficient for the purposes of this Act if the person concerned— 25
- (a) attends in person or by a legal practitioner or other agent, and is heard or states that he does not desire to be heard ; or
- (b) having received notice appointing a place and time, not less than seven days after service, at which he will be heard with reference to the matter or thing in the notice, fails to attend the hearing. 30
- (2) Notwithstanding the provisions of subsection (1) of this section, the Registrar in his discretion and whether or not the person concerned so attends or after notice given fails to attend, may adjourn the hearing from time to time ; and any such person may thereafter be heard at any subsequent meeting so adjourned. 35
- (3) Where by this Act persons appearing by the land register or any document in the possession of the Registrar to be interested or affected are to be given an opportunity of being heard, it shall be sufficient if all persons who, according to any subsisting entry in the land register or by such document, as the case may be, appear to be so interested or affected, are given such an opportunity. 40

156. No officer of the Land Registry or officer engaged for the purposes of adjudication under Part I of this Act shall be liable to any action, suit or proceeding for or in respect of any act matter or thing in good faith done or omitted to be done in exercise or purported exercise of the powers conferred upon any such officer by this Act.
- 157.—(1) Any person who—
- (a) knowingly misleads or deceives any person authorised under this Act to require information in respect of any land or interest in land ; or
- (b) fraudulently procures, assists in fraudulently procuring or is privy to the fraudulent procurement of any land certificate or instrument, or of any entry, erasure or alteration in the land register, or in any form issued by the Registrar ; or
- (c) fraudulently uses, assists in fraudulently using or is privy to the fraudulent using of any instrument or form purporting to be issued or authorised by the Registrar ; or
- (d) fraudulently removes from the Land Registry any part of a land register or any instrument filed in the Land Registry or causes any defacement, obliteration, mutilation or unauthorized entry or alteration to be made thereto,
- shall be guilty of an offence, and liable on conviction on indictment to a fine of five hundred pounds or to imprisonment for a term of three years, or to both, or liable on summary conviction to a fine of one hundred pounds or to imprisonment for a term of six months, or to both.
- (2) If any person fails without lawful excuse to comply with any order or direction of an adjudication officer he shall be guilty of an offence and be liable on summary conviction to a fine of one hundred pounds or to imprisonment for a term of six months, or to both.
- (3) If any person after delivery to him of a summons issued under this Act, wilfully neglects or refuses to attend in pursuance of such summons, or to produce any map, plan, instrument or other document which he is required to produce for the purposes of this Act, or to answer upon oath or otherwise any question which may be lawfully put to him by the Registrar or any other officer he shall be guilty of an offence and be liable on conviction to a fine of twenty pounds.
- 158.—(1) The Registrar may register any instrument notwithstanding the failure for any reason to pay the prescribed fee or any part thereof ; but in any such case a note of the fee or part of the fee remaining unpaid shall be entered in the land register, and the Registrar may refuse to register any further disposition of any land, lease or charge while a fee so noted is unpaid.
- (2) The Registrar may, accept the amount of the consideration for the purpose of determining the registration fees payable as the value of any land under this Act ; or may appoint a valuer and act on his certificate of valuation.
159. Expenses incurred by the Registrar and unpaid fees shall constitute a debt and may be recovered in legal proceedings brought by the Registrar.
160. An order for the payment of money made by the Registrar in the exercise of any power conferred upon him under this Act shall be deemed to be an order of a court and be enforceable in like manner.

Indemnity  
of officers.

Offences.

Additional  
powers of  
Registrar.Recovery of  
unpaid fees,  
etc.Enforcement  
of Registrar's  
orders of  
payment.

- Regulations. 161. Subject to the provisions of this Act, the Minister may make regulations prescribing—
- (a) the forms for use under this Act ;
  - (b) the fees to be paid under this Act or on the use of forms submitted for approval ;
  - (c) any other matter or thing, necessary for any of the purposes of this Act.
- Registration of instruments in special cases. 162. Notwithstanding the provisions of this Act as to the requirements of form for any instrument, if the Registrar is satisfied that an instrument is otherwise in order for registration and was executed before the date of the constitution of the land register intended to be affected or was executed within six months after that date, he may register the instrument on payment of the appropriate fees and certification of the instrument as prescribed by this Act.
- Restricted application of other Acts. 163.—(1) Where by reason of the declaration of an adjudication area this Act is to apply and a land register is opened for land brought under the provisions thereof, the Acts mentioned in the Schedule to this Act shall, with reference to any such land, cease to have effect.
- (2) Where any land is subject to this Act nothing herein shall, unless the contrary intention is shown, be construed as permitting any act, matter or thing otherwise prohibited by any other Act, or as dispensing with the requirement of any Act which prescribes approval by any person to any act, matter or thing.
- Interpretation. 164.—(1) In this Act unless the context otherwise requires—
- “adjudication area” means any area to which this Act is applied, and
  - “adjudication section” means any subdivision thereof made for the purposes of an adjudication under this Act ;
  - “adverse possession” includes the receipt of rent by a person wrongfully claiming the land in reversion ;
  - “Assurance Fund” means Registered Land Assurance Fund established for the purposes of claims under this Act ;
  - “certificate of title” means a certificate of title issued under the provisions of the Registration of Titles Act ;
  - “charge” means an interest in land securing the payment of money or money’s worth or the fulfilment of any condition and includes the interest in land known as mortgage, and “sub-charge” shall have the corresponding meaning ;
  - “chargee” means the proprietor of a charge ;
  - “chargor” means the proprietor of charged land or of a charged lease ;
  - “court” or “the court” means the High Court of Lagos and includes any court of superior jurisdiction ;
  - “demarcation officer” means an officer appointed under this Act to survey or otherwise mark out land within an adjudication area ;
  - “demarcation plan” means a plan prepared for an adjudication under this Act ;
  - “disposition” means any act performed *inter vivos* whereby the rights of persons in or over land or any lease or charge are affected otherwise than by an executory contract or agreement, and includes any acquisition by operation of law ;
- Cap. 181.

5

10

15

20

25

30

35

40

45

50

- 5 “easement” means any right which may be the subject of a deed of grant attaching to land whereby the use by the proprietor of the land is or may be restricted, or the use without ownership or occupation of the land is or may be enjoyed by the proprietor of adjoining or adjacent land ;
- “edition” with reference to the land register means the current title to land or to any lease thereof, as the case may be ;
- “encumbrance” includes any lease or charge capable of being registered under this Act ;
- 10 “guardian” means any person under customary law or otherwise responsible for protecting the interest of any person under disability by reason of age, unsoundness of mind or other cause whatsoever ;
- “the High Court” means the High Court of Lagos ;
- 15 “instrument” includes any deed, judgment, decree, order or other document in writing requiring or capable of registration under this Act ;
- “land” includes all things growing thereon and buildings and other things permanently affixed thereto, and where land is covered with water, the land itself, but does not include water, or any mine, minerals, mineral oil or mineral gas ;
- 20 “land certificate” means a certificate as evidence of ownership and other matters issued under this Act ;
- “land register” means the current edition of the register of land evidencing ownership by a proprietor under this Act, and includes a register of any lease thereof and any former register compiled for the purposes of this Act, and references to registration or entries therein shall be references to registration or entries in the relevant edition of the land register ;
- 25 “land registration district” means a district constituted for the purposes of registration of land under this Act ;
- 30 “Land Registry map” means the map compiled from a demarcation plan and kept by the Registrar for the purposes of this Act ;
- “lease” includes sublease but not an agreement for a lease ;
- 35 “lessee” means the holder of a lease ;
- “lessor” means the proprietor of leased land ;
- “Minister” means the Federal Minister for the time being charged with responsibility for registration of land ;
- “mutation record” means a record of changes in the Land Registry map kept by the Registrar under this Act ;
- 40 “parcel” means any area of land separately shown on the Land Registry map ;
- “powers” when used in reference to the Registrar and his subordinates, includes duties ;
- 45 “presentation book” means the book in which are recorded all applications for registration under this Act ;
- “profit a prendre” means a right to enter on the land of another and take substance therefrom either of the soil or products of the soil ;
- “proprietor” means the person registered under this Act as the owner of land or of any lease or charge ;

“registered land” means land registered under this Act ;  
 “registration officer” means the person appointed for the purposes of any adjudication under this Act ;  
 “Registrar” means the Registrar of Land under this Act and includes a deputy registrar and, to the extent to which he may be authorised by the Registrar, an assistant registrar ;  
 “registration section” means a division of a land registration district made by the Registrar on the Land Registry map ;  
 “transfer” means the acquisition of land, or any lease or charge by act of the parties and not by operation of law, and includes the instrument by which any such acquisition is effected ;  
 “transmission” means the acquisition of land or of any lease or charge by operation of law, and where land may be acquired compulsorily under any Act, includes any such acquisition ;  
 “valuable consideration” does not include any nominal consideration in money.

Cap. 181.

(2) References to registration means references to the making of any entry, note, or record in the land register under the provisions of this Act or, as the case may require, of the Registration of Titles Act, and cognate expressions shall have such extended meaning.

(3) References to an heir,—

(a) where used in relation to registered land which before or after the commencement of this Act is affected by customary law, or to other registered land if before the commencement of this Act, the proprietor or any person beneficially entitled has died or executed any deed or instrument importing a reference to an heir ; or

(b) where used in relation to unregistered land the subject of an investigation under this Act ; shall be construed and have effect as if this Act had not been passed, and in any other case the references shall be construed to refer to the personal representatives or other persons beneficially entitled.

(4) References to marriage expressed as consideration in any instrument, shall be construed as valuable consideration for the purposes of this Act

Short title, application and commencement.

165.—(1) This Act may be cited as the Registered Land Act, 1964, and shall apply to the Federal territory.

(2) This Act shall come into operation on a date to be fixed by the Minister by order in the Gazette.

SCHEDULE

Section 163(1)

Chapter	Enactments Affected Short Title	Extent affected
14	Arotas (Crown Grants) Act	The whole Act
44	Crown Grants (Lagos) Act	The whole Act
45	Crown Lands Act	Sections 31 and 33
61	Epetedo Lands Act	The whole Act
75	Glover Settlement Act	The whole Act
99	Land Registration Act	The whole Act
181	Registration of Titles Act	The whole Act

The following Bills, which will in due course be presented to Parliament for enactment, are published for general information.

## THE INSURANCE (MISCELLANEOUS PROVISIONS) BILL.

### EXPLANATORY MEMORANDUM

The purpose of this Bill is to secure the investment in Nigeria of certain reserves held by insurance companies for the purpose of meeting local risks and of the funds maintained by insurance companies for the purpose of satisfying their liabilities under life insurance policies and policies of a similar nature.

ZANNA BUKAR DIPCHARIMA,  
*Minister of Commerce and Industry*

## A BILL

### FOR

AN ACT TO PROVIDE FOR THE INVESTMENT IN NIGERIAN SECURITIES, BY PERSONS CARRYING ON BUSINESS AS INSURERS IN NIGERIA, OF CERTAIN ASSETS OF THE BUSINESS ; TO MAKE FURTHER PROVISION AS RESPECTS CERTAIN CONTRACTS OF INSURANCE ; AND FOR PURPOSES CONNECTED WITH THE MATTERS AFORESAID.

[See section 7(3)]

Commence-  
ment.

BE IT ENACTED by the Legislature of the Federation of Nigeria in this present Parliament assembled and by the authority of the same as follows :

- 5 1.—(1) A contract of insurance to which this section applies shall be void in so far as it makes provision for compensation in respect of local risks unless the party undertaking to pay the compensation is a Nigerian company.
- 10 (2) Where a person has, as a principal and not as a servant or agent, received in any financial year payments by way of premium made in respect of any period under contracts of insurance to which this section applies he shall, subject to the next following subsection, take such steps as may be necessary to secure that at all times during the next following financial year he is the owner of Nigerian investments which are free from encumbrances and equal in value to not less than two-fifths of such
- 15 proportion of the aggregate amount of those payments as is attributable in accordance with insurance practice to local risks ; and in calculating that proportion there shall be deducted the proportion so attributable to the local risks in question of the aggregate amount of any payments by way of premium made by that person under contracts of re-insurance in
- 20 respect of the same period or any part of it.

Additional provisions as respects insurance against local risks.

(3) A person who owns Nigerian investments in pursuance of the last foregoing subsection and who satisfies or proposes to satisfy a claim which—

(a) is made in respect of local risks in pursuance of a contract of insurance to which this section applies, or of such a contract as renewed with or without modifications ; and 5

(b) falls to be treated in accordance with insurance practice as an abnormally large claim,

shall not be treated as failing to comply with the provisions of that subsection if— 10

(i) he realises or charges such of the investments as is appropriate in accordance with insurance practice for the purpose of satisfying that claim or of replacing moneys used to satisfy it ; and

(ii) the period in respect of which he relies on the provisions of paragraph (i) of this subsection in connection with that claim does not exceed thirty days. 15

(4) A person who fails to comply with the provisions of subsection (2) of this section shall be guilty of an offence and liable on conviction on indictment to a fine of an amount not exceeding one thousand pounds.

(5) This section applies to contracts of insurance made on or after the date when this subsection comes into force, other than contracts of endowment insurance and contracts of such descriptions, if any, as may be prescribed for the purposes of this section. 20

(6) The foregoing provisions of this section shall come into force on such date as the Minister may by order appoint (not being earlier than the first day of April, one thousand nine hundred and sixty-four), and different dates may be so appointed for different subsections ; and subsection (2) of this section shall, as respects the financial year next following that in which that subsection comes into force, have effect as if for the words "two-fifths" there were substituted the words "one-fifth". 25 30

Additional provisions as respects endowment insurance.

2.—(1) A contract of endowment insurance made in Nigeria on or after the date when this section comes into force under which payments by way of benefit are expressed to become payable in respect of an individual who is a citizen of Nigeria at the time when the contract is made shall be void unless— 35

(a) the party undertaking to make the payments is a Nigerian company ; and

(b) the contract is a Nigerian contract of endowment insurance ; so however that the foregoing provisions of this subsection shall not apply to a contract of re-insurance if it does not provide for the making of payments corresponding to payments by way of benefit in respect of any individual which in the aggregate are less than, or of less value than, forty thousand pounds. 40

(2) Every person who, as a principal and not as a servant or agent, carries on endowment insurance business shall take such steps as may be necessary to secure that, on and after the first day of April, one thousand nine hundred and sixty-six, he is the owner of Nigerian investments free from encumbrances which are equal in value to the aggregate of — 45

5 (a) the value at the time of the close of business on the thirty-first day of March, one thousand nine hundred and sixty-two, of such of the assets of each relevant fund as are attributable in accordance with insurance practice to Nigerian contracts of endowment insurance; and

(b) the value of such of the assets paid or credited to each relevant fund after the time aforesaid as are so attributable, reduced by the amount of any payments made out of the relevant fund in question after the time aforesaid for the purpose of satisfying liabilities and expenses so attributable which fall to be satisfied out of that fund in accordance with insurance practice.

10  
15 In this subsection "relevant fund", in relation to a person carrying on endowment insurance business, means a fund maintained by him to which are paid or credited moneys received by him for the purposes of the business.

20 (3) In relation to a person who begins to carry on endowment insurance business after the thirty-first day of March, one thousand nine hundred and sixty-two, the references in the last foregoing subsection to that date shall be construed as references to the thirty-first day of March of the year next following that in which he begins to carry on the business.

25 (4) Where apart from this subsection any amount in respect of payments by way of premium under a contract of endowment insurance would, under the provisions of the Income Tax Management Act, 1961, fall to be deducted in ascertaining, in respect of any year of assessment within the meaning of that Act beginning after the end of the year one thousand nine hundred and sixty-four, the income or loss for income tax purposes of any individual, the amount to be so deducted shall not exceed a sum equal to one-third of the payments in question unless  
30 either—

1961,  
No. 21.

(a) the contract is a Nigerian contract of endowment insurance; or

35 (b) the individual furnishes to the Board of Inland Revenue a certificate in the prescribed form issued by the person by whom payments by way of benefit fall to be made in pursuance of the contract stating that the last-mentioned person is the owner of Nigerian investments which are—

(i) free from encumbrances; and

(ii) equal in value to the aggregate of the relevant payments by way of premium; and

40 (iii) allocated to those payments in accordance with regulations made in pursuance of paragraph (b) of section four of this Act; or

(c) the contract was made before the first day of March, one thousand nine hundred and sixty-four.

This subsection applies to Lagos only.

45 (5) A person who fails to comply with the provisions of subsection (2) of this section shall be guilty of an offence and liable on conviction on indictment to a fine of an amount not exceeding one thousand pounds;

and a person who issues a certificate for the purposes of paragraph (b) of the last foregoing subsection which he knows to be false in a material particular or recklessly issues such a certificate which is false in a material particular shall be guilty of an offence and liable on summary conviction to imprisonment for a term not exceeding six months or a fine of an amount not exceeding two hundred pounds or both.

Appoint-  
ment and  
functions of  
inspector.

1961,  
No. 53.

3.—(1) There shall be an inspector for the purposes of this Act, whose office shall be an office in the department of government for which responsibility is assigned to the Minister and who shall be a person having such qualifications and experience as are appropriate for a person required to perform the functions conferred on the inspector by virtue of this Act; so however that, if the Public Service Commission of the Federation so directs, the person who is the registrar for the purposes of the Insurance Companies Act, 1961, shall also be the inspector for the purposes of this Act.

(2) Provision may be made by regulations as to the functions of the inspector and, without prejudice to the generality of the power to make regulations conferred by the foregoing provisions of this subsection, the regulations may in particular include provision—

(a) requiring copies of records maintained in pursuance of this Act to be furnished to the inspector periodically and on such specific occasions as he may determine;

(b) authorising the inspector to examine and take copies of or extracts from any books or papers appearing to him to be connected with contracts of insurance, and requiring persons having such books and papers in their possession or under their control to produce them for examination by the inspector;

(c) requiring persons appearing to the inspector to be, or to have been, carrying on business as insurers in Nigeria to furnish to him, either orally or in writing as he may direct, any information relating to the business which he may reasonably require them to furnish for the purpose of enabling the inspector to satisfy himself whether provisions of this Act or of regulations have been infringed.

(3) It shall be the duty of the inspector in exercising his functions not to interfere unreasonably with the affairs of persons affected by his activities.

(4) Any power conferred on the inspector by virtue of this Act may be exercised by the inspector in person and by any public officer who produces an instrument signed by the inspector authorising him to exercise that power on behalf of the inspector; and references to the inspector in this section shall be construed accordingly.

Supple-  
mentary  
administra-  
tive  
provisions.

4. Without prejudice to any other power to make regulations conferred by this Act, provision may be made by regulations—

(a) for securing that a person who is required to own Nigerian investments by virtue of this Act shall maintain in accordance with the regulations a record containing—

(i) particulars of the investments from time to time owned by him for the purposes of this Act; and

(ii) particulars of the contracts in respect of which the investments are owned; and

(iii) such other particulars, if any, as may be prescribed;

(b) for requiring a person who proposes to issue a certificate for the purposes of paragraph (b) of subsection (4) of section two of this Act to allocate Nigerian investments, in accordance with the regulations, to the payments in respect of which he proposes to issue the certificate; and

(c) as to the manner of determining—

(i) any value falling to be determined for the purposes of this Act; and

(ii) whether a loan is adequately secured for those purposes by a mortgage or charge.

5.—(1) In this Act, "Nigerian investments" means property of any of the following descriptions, that is to say—

Nigerian investments.

(a) stock, notes, bonds and other securities issued by the government of the Federation or a Region;

(b) stock, shares and debentures issued by a body corporate established directly by a law in force in Nigeria, or issued by a Nigerian company;

(c) rights to receive payments by way of interest or dividend which have accrued due in respect of any such securities as are mentioned in the foregoing paragraphs;

(d) moneys standing to the credit of any current or deposit account maintained with a branch situated in Nigeria of a licenced bank within the meaning of the Banking Act;

(e) moneys standing to the credit of any deposit account maintained with a person who is carrying on business in Nigeria as a building society and is approved by the Minister for the purposes of this paragraph;

(f) an estate in fee simple absolute in possession in land in Nigeria, and a term of years absolute in possession in such land;

(g) rights to be repaid a loan which is adequately secured by a first mortgage of such an estate or term as is mentioned in the last foregoing paragraph, or by a first charge on machinery or plant situated in Nigeria;

(h) rights to receive payments by way of premium which have accrued due under contracts of insurance made in Nigeria;

(i) rights to be repaid a loan made in Nigeria to any person in consequence of his being a person who has undertaken to make payments by way of premium under a contract of endowment insurance, and rights to receive payments by way of interest which have accrued due on such a loan;

(j) property of such other descriptions, if any, as may be prescribed.

(2) Where by virtue of any provision of this Act a person is required to own Nigerian investments of any amount, he shall not be treated as satisfying that requirement unless—

(a) the investments allocated by him to satisfy that requirement include investments of the description mentioned in paragraph (a) of the foregoing subsection equal in value to one quarter of the amount in question; and

(b) the investments so allocated do not include investments of the description mentioned in paragraph (f) of that subsection which exceed in value one-tenth of the amount.

Cap. 19.

Interpretation, etc.

6.—(1) In this Act the following expressions have the meanings hereby assigned to them respectively, that is to say—

“contract of endowment insurance” means a contract of insurance in which benefit is expressed to become payable on the occurrence of an event or circumstance which is certain to occur, or on the occurrence of any of a number of events or circumstances of which at least one is certain to occur, other than a contract of such description, if any, as may be prescribed for the purposes of this definition ;

“endowment insurance business” means the business of undertaking liability to make payments by way of benefit under contracts of endowment insurance in so far as the business is carried on in Nigeria ;

“insurance” includes re-insurance, and references to contracts of insurance shall be construed accordingly ;

“insurance practice” means normal insurance practice in Nigeria ;

“local risk” means an event or circumstance occurring within Nigeria ;

“the Minister” means the Minister of the government of the Federation responsible for insurance ;

“Nigerian company” means a company which is formed and registered under the Companies Act or which complies with the provisions of subsection (1) of section two hundred and thirty-nine of that Act (which relate to companies incorporated outside Nigeria which establish places of business within Nigeria) and includes, except in section five of this Act, an association of underwriters registered under the Insurance Companies Act, 1961, and any member of such an association ;

“Nigerian contract of endowment insurance” means a contract of endowment insurance which provides that all payments falling to be made in pursuance of the contract shall be payable in Nigerian money only ;

“prescribed” means prescribed by regulations ; and

“regulations” means regulations made by the Minister ;

and references in this Act to payments by way of benefit under a contract of endowment insurance shall be construed, in relation to such a contract which is a contract of re-insurance, as references to payments under the contract of re-insurance corresponding to payments by way of benefit.

(2) For the avoidance of doubt it is hereby declared that where a contract of insurance is renewed, the renewal constitutes a new contract of insurance for the purposes of this Act.

(3) Nothing in this Act shall be construed as purporting to affect any insurance undertaken by the government of a Region which does not extend beyond the limits of the Region.

Short title, extent, commencement and repeals.

7.—(1) This Act may be cited as the Insurance (Miscellaneous Provisions) Act, 1964.

(2) Except as provided by subsection (4) of section two of this Act, this Act shall apply throughout the Federation.

(3) Subject to the provisions of subsection (6) of section one of the Act, this Act shall come into force on such date as the Minister may by order appoint.

(4) Section twenty-eight of the Insurance Companies Act, 1961, and paragraph (b) of subsection (2) of section forty-four of that Act 5 (which contain provisions for requiring insurance companies to invest a percentage of their profits in Nigeria) are hereby repealed.

(800)



## THE BILLS OF EXCHANGE BILL

## EXPLANATORY MEMORANDUM

The main purpose of this Bill is to enable bankers to pay or collect cheques and certain other instruments without concerning themselves with endorsements in cases where payment is made to a banker or the proceeds are collected for crediting to the account of the ostensible payee.

F. S. OKOTIE-EBOLI,  
*Minister of Finance*

## A BILL

## FOR

AN ACT TO AMEND THE LAW RELATING TO BILLS OF EXCHANGE ; AND FOR PURPOSES CONNECTED THEREWITH.

[See section 5 (2)]

Commencement.

BE IT ENACTED by the Legislature of the Federation of Nigeria in this present Parliament assembled and by the authority of the same as follows :—

5 1.—(1) Where a banker, in good faith and in the ordinary course of business, pays a prescribed instrument drawn on him to a banker, he does not in doing so incur any liability by reason only of the absence of, or irregularity in, endorsement of the instrument and—

Payment by bankers of unendorsed cheques and other instruments.

(a) in the case of a cheque, he is deemed to have paid it in due course ;

10 (b) in the case of any other prescribed instrument, the payment discharges the instrument.

(2) A prescribed instrument which is unendorsed but appears to have been paid by the banker on whom it is drawn is evidence of the receipt by the payee of the sum mentioned in the instrument.

15 (3) For the purposes of subsection (1) of section sixty of the Bills of Exchange Act (which provides that in certain circumstances a cheque shall be deemed to be paid in due course though its endorsements are forged or unauthorised), a document payable to order which is a prescribed instrument by virtue of paragraph (b) of subsection (1) of  
20 section four of this Act shall be deemed to be a bill payable to order on demand.

Cap. 21.

25 2.—(1) A banker who gives value for, or has a lien on, a cheque payable to order which the payee delivers to him for collection either without endorsing it or without endorsing it regularly has such rights, if any, as he would have had if upon delivery the payee had endorsed it regularly in blank.

Protection of collecting bankers.

(2) Where a banker, in good faith and without negligence,—

(a) receives payment for a customer of a prescribed instrument to which the customer has no title or a defective title ; or

(b) having credited the customer's account with the amount of such a prescribed instrument, receives payment of the instrument for himself,

the banker does not incur any liability to the true owner of the instrument by reason only of his having received payment of it ; and a banker is not to be treated for the purpose of this subsection as having been negligent by reason only of his failure to concern himself with the absence of, or irregularity in, endorsement of a prescribed instrument of which the customer in question appears to be the payee.

(3) Section eighty-two of the Bills of Exchange Act (which contains provisions as to crossed cheques which are included in the provisions of subsection (2) of this section) is hereby repealed.

Extension of enactments relating to crossed cheques.

3. The provisions of the Bills of Exchange Act relating to crossed cheques shall, so far as applicable, have effect in relation to a prescribed instrument other than a cheque as those provisions have effect in relation to a cheque.

Interpretation, etc.

4.—(1) In this Act “prescribed instrument” means any of the following instruments, that is to say—

(a) a cheque ;

(b) a document issued by a customer of a banker which is not a bill but is intended to enable a person to obtain payment from the banker of the sum mentioned in the document ;

(c) a draft drawn by a banker upon himself and payable on demand at an office of his bank.

(2) This Act shall be construed as one with the Bills of Exchange Act, so however that references in this Act to a payee do not include references to an endorsee under a special endorsement.

(3) Nothing in this Act shall make negotiable an instrument which apart from this Act is not negotiable.

Short title, extent and commencement.

5.—(1) This Act may be cited as the Bills of Exchange Act, 1964, and shall apply throughout the Federation.

(2) This Act shall come into force on such day as the Minister of the government of the Federation responsible for finance may by order appoint.

## THE PRESIDENTIAL PROCEEDINGS BILL

## EXPLANATORY MEMORANDUM

The purpose of this Bill is to make the detailed provisions about the election and removal of the President of the Republic which are contemplated by Chapter IV of the Constitution of the Federation.

T. O. ELIAS,  
*Attorney-General of the Federation and  
Minister of Justice*

## ARRANGEMENTS OF CLAUSES

<i>Clause</i>	<i>Declaration of election of President, etc.</i>
<i>Joint meetings of Houses of Parliament</i>	6. Declaration and evidence of election.
1. Procedure at certain joint meetings of Houses of Parliament.	<i>Investigation of conduct of President</i>
<i>Presidential ballots, etc.</i>	7. Establishment and attendance at meetings of investigating com- mittee.
2. Arrangements connected with bal- lots.	8. Powers and procedure of com- mittee.
3. Voting.	9. Report to Parliament.
4. Counting of votes, etc.	<i>Supplemental</i>
5. Application of sections 2 to 4 to ancillary ballots.	10. Short title, extent and interpreta- tion.

## A BILL

## FOR

AN ACT TO MAKE SUPPLEMENTARY PROVISION FOR THE PURPOSES OF CHAPTER IV OF THE CONSTITUTION OF THE FEDERATION AS RESPECTS THE ELECTION AND REMOVAL OF THE PRESIDENT OF THE REPUBLIC ; AND FOR PURPOSES CONNECTED THEREWITH.

[ ]

Commence-  
ment.

BE IT ENACTED by the Legislature of the Federation of Nigeria in this present Parliament assembled and by the authority of the same as follows :—

*Joint meetings of Houses of Parliament*

- 5 1.—(1) At any joint meeting of both Houses of Parliament held in pursuance of Chapter IV of the Constitution of the Federation (which among other things provides for the election and removal of the President) the following person shall preside, that is to say—  
(a) the President of the Senate ;

Procedure  
at certain  
joint  
meetings  
of Houses  
of Parlia-  
ment.

- (b) in his absence, the Speaker of the House of Representatives ;
- (c) in their absence, the Deputy President of the Senate ;
- (d) in the absence of the persons aforesaid, the Deputy Speaker of the House of Representatives ;

and while none of those persons is present, such member of either House as the Prime Minister may designate from time to time shall preside at the joint meeting. 5

(2) The President of the Senate and the Speaker of the House of Representatives, acting jointly, may make rules regulating, subject to the provisions of the said Chapter IV and this Act, the conduct of joint meetings ; and except so far as it is otherwise provided by rules made in pursuance of this subsection, the Standing Orders of the House of Representatives which on the twelfth day of December, 1962, were ordered by that House to be printed shall, subject as aforesaid, apply with the necessary modifications to joint meetings as they apply to meetings of that House. 10 15

(3) Any question arising at a joint meeting as to the application or interpretation of provisions of the rules or standing orders aforesaid shall be determined by the person presiding at the joint meeting when the question arises ; and any question arising at a joint meeting which in the opinion of that person is not regulated by those provisions shall be determined by him. 20

#### *Presidential ballots, etc.*

Arrange-  
ments  
connected  
with  
ballots.

2.—(1) It shall be the duty of the President of the Senate to make arrangements for securing that, when a presidential ballot is ordered, there are available for the purposes of the ballot— 25

(a) a list of the persons entitled to vote at the relevant election meeting ;

(b) five hundred ballot papers capable of being folded and bearing on their reverse sides consecutive serial numbers only, each of which is attached to a counterfoil bearing only the same number as the ballot paper to which it is attached ; 30

(c) an instrument for affixing the special mark mentioned in subsection (2) of the next following section ;

(d) such number of compartments (not being less than twelve) at the place where the relevant election meeting is held as he considers appropriate for securing that each person voting in the ballot is able to mark his ballot paper screened from observation and that the ballot is speedily concluded ; and 35

(e) a single ballot box. 40

(2) The person by whom a presidential ballot is ordered shall specify the premises to be used for the purposes of the ballot and shall secure—

(a) that the premises are adequate to accommodate at the same time all the persons entitled to vote at the relevant election meeting and such officials as he may designate to assist at the ballot ; 45

(b) that no person other than the persons so entitled and the officials aforesaid is admitted to those premises after the ballot is ordered ;

5 (c) that every person so entitled (other than a witness designated in pursuance of paragraph (e) of this subsection) leaves those premises forthwith after casting his vote and is not thereafter admitted to those premises before the ballot is declared closed ;

10 (d) that no person so entitled who is not already on those premises is admitted to the premises after the expiration of one hour from the time when the ballot was ordered and before the ballot is declared closed ; and

15 (e) that, subject to subsection (4) of this section, the compartments, ballot box and unused ballot papers aforesaid allocated to the ballot are, throughout the period beginning with the ordering of the ballot and ending with the declaration of its result, within the immediate view of the following persons, that is to say—

(i) one member of each House of Parliament designated for the purposes of the ballot by the Prime Minister ; and

20 (ii) one member of either House of Parliament designated for the purposes of the ballot by each candidate in the ballot respectively.

25 (3) A designation in pursuance of paragraph (e) of the last foregoing subsection shall be made by notice in writing served on the person who ordered the ballot in question ; and in relation to that ballot the persons designated in pursuance of that paragraph by the Prime Minister are hereafter in this Act referred to as "the official witnesses" and a person so designated by a candidate is hereafter in this Act referred to as a "candidate's witness".

30 (4) If the power of designation conferred on a particular candidate by sub-paragraph (ii) of the said paragraph (e) is not exercised by him before the expiration of the period of five minutes beginning with the time when the relevant ballot is ordered, that power shall not be exercised by him in relation to that ballot ; but nothing in the foregoing provisions of this section shall be construed as preventing an official witness or a candidate's witness from complying with the provisions  
35 of subsection (3) of the next following section for the purpose of voting in a presidential ballot.

3.—(1) Each ballot paper for use in a presidential ballot shall, without prejudice to the requirements of the next following subsection, bear on its face only the names of the persons who are candidates  
40 for election in the ballot. Voting.

(2) When a presidential ballot is ordered, the person who ordered it shall forthwith determine what special mark shall be affixed to ballot papers and counterfoils to be used in the ballot, and the mark shall—

45 (a) be such as will identify the papers and counterfoils as valid only for that particular ballot ; and

(b) be affixed by embossing or perforating it on the paper and its counterfoil immediately before the paper is detached from its counterfoil and handed to the voter by whom it is to be used ;

and the ballot paper issued to each voter shall be taken at random from among the remaining ballot papers allocated to the ballot and not in such a sequence or other manner as to permit the identification of the voter to whom it was issued.

(3) A person voting in a presidential ballot shall cast his vote by— 5

(a) obtaining in person a ballot paper marked with the appropriate special mark from the officer instructed by the person who ordered the ballot to issue the ballot papers for that ballot ; and

(b) immediately thereafter entering one of the compartments provided in pursuance of the last foregoing section so that he is 10  
screened from view and there—

(i) marking a cross on the paper at the end of the name of a single candidate for whom he casts his vote ; and

(ii) folding the paper so that the face of it is not visible ; and

(c) immediately thereafter and without unfolding the paper, 15  
showing the special mark on it to the official from whom he received the paper and placing the paper in the ballot box indicated by that official.

(4) A person to whom a ballot paper is issued in pursuance of the last foregoing subsection shall, subject to the following provisions of this subsection, not be entitled to dispose of the paper otherwise than in the manner provided by that subsection ; but if such a person marks his ballot paper in a manner other than that which he intends, he may, before placing the paper in the ballot box in accordance with the last foregoing subsection but not thereafter, return the paper to 25  
the official from whom he received it, and the official shall thereupon—

(a) issue him with a further ballot paper for that ballot ; and

(b) burn the returned paper and record on its counterfoil the fact that it has been burnt and the number of the further paper.

(5) Not more than two further ballot papers shall be issued in 30  
pursuance of subsection (4) of this section to the same person for the purposes of the same presidential ballot ; and where the number of ballot papers provided for a particular ballot in pursuance of paragraph (b) of subsection (1) of the last foregoing section is insufficient to enable effect to be given to the foregoing provisions of this section, the person 35  
by whom the ballot was ordered shall make such arrangements as he considers appropriate for furnishing such additional similar ballot papers as may be necessary for meeting the deficiency.

(6) When a ballot paper or further ballot paper is issued to any person in pursuance of this section, the official who issued the paper shall record against the name of that person on the list of persons 40  
entitled to vote at the relevant election meeting the fact that a ballot paper or further paper has been issued to him ; but no record shall be made, either on the list or elsewhere, of the number of any ballot paper issued to a particular person. 45

(7) When, at any time after the expiration of one hour from the time when a presidential ballot was ordered, it appears to the person who ordered it that all persons eligible to vote in the ballot and present in the premises specified in pursuance of subsection (2) of the last

foregoing section have had a reasonable opportunity of casting their votes, he shall declare the ballot to be closed; and no vote shall be cast in the ballot after the declaration is made.

4.—(1) When a presidential ballot is declared closed, the ballot papers used in the ballot shall forthwith be scrutinised, and the votes entered on the papers in favour of each candidate respectively counted and recorded, by the official witnesses and the person who ordered the ballot acting jointly (hereafter in this section referred to as "the scrutineers") and shall be so scrutinised, counted and recorded in the premises specified in pursuance of subsection (2) of section two of this Act and in the immediate view of the candidates' witnesses.

Counting of votes, etc.

(2) In counting and recording the votes aforesaid there shall be disregarded any ballot paper which, in the opinion of the scrutineers or any two of them,—

- (a) does not bear the appropriate special mark; or
- (b) is not marked with a vote; or
- (c) is marked with a vote in such manner as not to indicate a particular candidate as the sole candidate for whom the vote is cast; or
- (d) is marked in such a manner as to enable the voter to be identified; or
- (e) bears the same serial number as any other ballot paper which purports to have been used in the ballot and which does not fall to be disregarded in pursuance of any of the foregoing paragraphs of this subsection;

but, subject to the foregoing provisions of this subsection, the fact that a ballot paper is marked elsewhere than at the proper place or otherwise than by means of a cross shall not entitle the scrutineers to disregard the paper if they or any two of them are of opinion that the paper clearly indicates an intention to vote for a particular candidate.

(3) On completing the recording of the votes cast in a presidential ballot the scrutineers shall exhibit the record to the candidates' witnesses; and if—

- (a) in the opinion of the scrutineers or any two of them a recount of the votes is appropriate; or
- (b) any candidate's witness demands a recount of the votes and in the opinion of the scrutineers or any two of them the demand is reasonable,

the scrutineers shall forthwith order a recount of the votes and proceed in accordance with subsections (1) and (2) of this section as upon a declaration that the ballot is closed.

(4) Where a record is exhibited to the candidates witnesses in pursuance of the last foregoing subsection and no recount is ordered, the person who ordered the ballot shall forthwith announce the result of the ballot to the joint meeting.

5. The provisions of sections two to four of this Act shall, subject to the provisions of subsection (9) of section thirty-five of the Constitution of the Federation, apply to a ballot held in pursuance of subsection (8) of that section (which provides for the elimination of one of two candidates in a presidential ballot where each receives the same number of votes which is less than the number received by a further candidate) as those provisions apply to a presidential ballot.

Application of ss.2 to 4 to ancillary ballots.

*Declaration of election of President, etc.*

Declaration  
and  
evidence  
of election.

6.—(1) Where the result of a presidential ballot is that a candidate is elected as the President of the Republic, the person presiding at the joint meeting when the result is announced shall forthwith—

(a) declare that candidate to be so elected; and

(b) execute in duplicate in the presence of the official witnesses and in accordance with subsection (11) of section thirty-six of the Constitution of the Federation (which provides for proof of the election of a person as the President) such an instrument as is mentioned in that subsection.

(2) Each of the official witnesses shall sign his name upon the instruments aforesaid in witness of their execution, and one of those instruments shall be deposited and preserved in the records of the Senate and the other in the records of the House of Representatives; and rules made by the President of the Senate and the Speaker of the House of Representatives, acting jointly, may provide for the issue of authenticated copies of the instruments.

*Investigation of conduct of President*

Establish-  
ment and  
attendance  
at meetings  
of  
investiga-  
ting  
committee.

7.—(1) Subject to the next following subsection, the committee mentioned in subsection (5) of section thirty-eight of the Constitution of the Federation (which provides for a committee of members of Parliament to investigate and report to Parliament on the conduct of the President of the Republic where a motion for the investigation is passed by a joint meeting) shall consist of—

(a) four persons nominated in writing by the Prime Minister, of whom two shall be Senators and the others shall be members of the House of Representatives and of whom one shall be designated by the Prime Minister as the chairman of the committee; and

(b) four Senators nominated by resolution of the Senate; and

(c) four members of the House of Representatives nominated by resolution of that House.

(2) The powers of nomination conferred by paragraphs (b) and (c) of the foregoing subsection shall, without prejudice to any nomination made in the exercise of those powers during the period of four days beginning with the date of the passing of the motion in consequence of which the committee is set up, not be exercisable as respects the committee after the expiration of that period.

(3) There shall be a legal assessor to the committee, who shall be a judge of the Supreme Court nominated in writing by the Prime Minister.

(4) It shall be the duty of every member of the committee and the legal assessor to be present throughout every meeting of the committee unless he is excused from attendance by the committee on the ground of serious illness; and a person who—

(a) is so excused; or

(b) without being so excused is absent from a meeting of the committee,

shall cease to be a member of the committee or its assessor, as the case may be, and shall, in a case falling within paragraph (b) of this subsection, be guilty of contempt of the committee and punishable accordingly.

5 (5) Where the chairman of the committee or its legal assessor dies or ceases to hold office by virtue of the last foregoing subsection, then—

(a) in the case of the chairman, the Prime Minister shall designate  
 10 an existing member of the committee (whether or not a person nominated as a member by the Prime Minister) to be its chairman; and

(b) in the case of the legal assessor, the power to nominate a legal assessor shall again be exercised;

15 but no person shall be nominated as a member of the committee in the place of a person who has ceased to be such a member.

8.—(1) The committee shall, during the period beginning with the date of its first meeting and ending with the date of its dissolution, be a superior court of record.

(2) The committee shall meet at such times and places as the chairman of the committee may determine, and the chairman shall so exercise  
 20 his powers under this subsection as to secure that the business of the committee is concluded with all reasonable speed and within the period of three months mentioned in subsection (5) of section thirty-eight of the Constitution of the Federation; and every meeting of the committee shall, except so far as the committee otherwise determines, be  
 25 held in public.

(3) Any question for determination by the committee shall be determined by the votes of a majority of the members of the committee; and in case of an equality of votes the chairman of the committee shall  
 30 exercise a second or casting vote.

(4) Subject to subsections (2), (3) and (9) of this section, the President of the Senate, the Speaker of the House of Representatives and the Attorney-General of the Federation, acting jointly, may make  
 35 rules as to the procedure to be followed and the rules of evidence to be observed in proceedings before the committee; and except so far as is otherwise provided by this Act or by rules made in pursuance of this subsection, the rules of procedure to be followed and the rules of evidence to be observed in proceedings before the committee shall, subject  
 40 to the necessary modifications, be the same as those having effect with respect to proceedings on indictment in the High Court of Lagos.

(5) Any question as to the application or interpretation, in relation to proceedings of the committee, of any such rules as are mentioned in the last foregoing subsection shall be determined by the committee, and the committee shall, before making a determination in pursuance  
 45 of this subsection, take into consideration the advice of the legal assessor on the question; and where such a determination is, in the opinion of the assessor, not in accordance with his advice, the assessor shall state his opinion and the reasons for it to the committee and the committee shall include in its report to Parliament a statement of the determination  
 50 and of the advice, opinion and reasons aforesaid.

Powers and procedure of committee.

(6) The committee may, if it thinks fit, appoint such legal practitioners as it considers appropriate to assist the committee in the conduct of its proceedings.

(7) No process touching the committee or its proceedings shall issue out of any court except—

(a) at the instance of the committee ; or

(b) for the purpose of securing the attendance of witnesses or the production of evidence in connection with proceedings before the committee ; or

(c) in connection with an alleged offence of perjury committed in connection with such proceedings.

(8) No punishment for contempt of the committee shall be imposed by the committee on any person except with the concurrence of the legal assessor.

(9) Where a new legal assessor is nominated in pursuance of subsection (5) of the last foregoing section then, except so far as the committee otherwise determines with the consent of the person whose conduct is the subject of its proceedings, it shall be the duty of the committee, without prejudice to its power to take again any evidence previously given before the committee, to disregard for the purposes of its report any proceedings before the committee which took place before the nomination of the new assessor.

Report to Parliament.

9.—(1) The report of the committee on the conduct of the President of the Republic shall be in writing and the committee shall present the report to Parliament by causing a copy of the report to be served on the Clerk to the Senate.

(2) It shall be the duty of the Clerk to the Senate forthwith to cause a report served on him in pursuance of this section to be printed and a printed copy of it to be made available to each Senator and each member of the House of Representatives respectively.

(3) On the presentation of its report to Parliament, the committee shall stand dissolved.

### Supplemental

10.—(1) This Act may be cited as the Presidential Proceedings Act, 1964, and shall apply throughout the Federation.

(2) In this Act—

“candidate’s witness” and “official witnesses” have the meanings assigned to them by subsection (3) of section two of this Act ;

“election meeting” and “presidential ballot” have the same meanings as in section thirty-five of the Constitution of the Federation ; and

“joint meeting” means a joint meeting of both Houses of Parliament held in pursuance of Chapter IV of the Constitution of the Federation.

Short title, extent and interpretation.

L.N. 24 of 1964

THE LAGOS LOCAL GOVERNMENT ACT, 1959  
(No. 18 OF 1959)

The Lagos General Rate Order, 1964

Commencement : 1st April, 1964

In exercise of the powers conferred on the Lagos City Council by section 135 of the Lagos Local Government Act, 1959, the following Order has been made with the approval of the Minister of Lagos Affairs.

1. This Order may be cited as the Lagos General Rate Order, 1964. Citation.
2. A yearly rate shall be levied in respect of the financial year commencing on the 1st April, 1964, in respect of the tenements referred to in the First and Second Schedules hereto. Yearly rate.
3. Such yearly rate shall be calculated : Calculation of yearly rate.
  - (a) at the rate of ten shillings for each pound at the annual value of the tenements referred to in the First Schedule other than those specified in paragraphs (b) and (c) of this section.
  - (b) at the rate of ten shillings for each pound of five *per cent* of the depreciated capital value (as defined in the Assessment and Rating (Public Utility Corporations) Act 1956) of tenements (other than tenements used as dwelling houses) of the following public utility corporations :—
    - (i) the Electricity Corporation of Nigeria ;
    - (ii) the Nigerian Ports Authority ;
    - (iii) the Nigerian Railway Corporation ;
  - (c) at the rate of ten shillings for each pound of the annual value of the tenements referred to in the First Schedule which are occupied by any social club constituted solely for the purpose of any game or sport ;
  - (d) at the rate of one-and-a-half *per cent* of the unimproved value of the tenements referred to in the Second Schedule other than those specified in paragraph (e) of this section and ;
  - (e) at the rate of one *per cent* of the annual value of the tenements referred to in the Second Schedule which are occupied by any social club or club constituted solely for the purpose of any game or sport.
4. The date on which the said general rate shall become due and payable shall be as to one-half thereof on the 1st April, 1964 and as to the other half thereof on the 1st October, 1964. Date of payment.
5. The following tenements shall be totally exempted from the payment of the said general rate :—
  - (a) tenements on which no building whether of a permanent or temporary nature is erected, when such tenements are not assessed, by reference to their unimproved value ;
  - (b) tenements owned by the Government of the Federation of Nigeria and the Lagos City Council ;
  - (c) places of worship, cemeteries and public parks and recreation grounds ;

(d) tenements occupied by schools in so far as they are occupied and used solely for schools as distinct from residential purposes, and

(e) tenements assessed by reference to their annual value of which the annual value does not exceed six pounds.

Revocation  
of previous  
Order L.N  
No. 53 of  
1963.

6. The Lagos General Rate Order 1963 is hereby revoked without prejudice to the recovery of any amounts due thereunder.

### FIRST SCHEDULE

All tenements within the City of Lagos which are assessed or which may hereafter be assessed in accordance with the Assessment Act as amended by the Assessment and Rating (Public Utility Corporations) Act, 1956, except the tenements referred to in the Second Schedule.

### SECOND SCHEDULE

All tenements situated within the area known as the Yaba Estate which are assessed by reference to their unimproved value, so long as they remain so assessed.

MADE by the Lagos City Council this 27th day of December, 1963.

S. J. MAYAKI,  
*Town Clerk*

APPROVED by the Minister of Lagos Affairs this 29th day of January, 1964.

J. C. A. WARMANN,  
*Acting Permanent Secretary,  
Ministry of Lagos Affairs*

### EXPLANATORY NOTE

This Order proposes to levy a general rate of ten shillings in the £ during the financial year commencing on 1st April, 1964. The rate shall be payable in two equal instalments at 1st April and 1st October, 1964. The rate is same as for the 1963-64 Financial year.

L0217/III

L.N. 25 of 1964

EXCISE TARIFF ACT, 1958  
(No. 58 of 1958)

## The Excise Duties (Amendment) Order, 1964

Commencement : 9th March, 1964

In exercise of the powers conferred by subsection (1) of section 3 of the Excise Tariff Act, 1958, the President has made the following Order—

1. This Order may be cited as the Excise Duties (Amendment) Order, 1964, and shall apply throughout the Federation.

2. The Schedule to the Excise Tariff Act, 1958, as the same was replaced by the Excise Duties (Amendment No. 2) Order, 1959, is revoked and replaced by the following—

Citation and Application.

Replacement of Schedule of Schedule to No 58 of 1958. L.N. 159 of 1959.

## SCHEDULE

## GOODS LIABLE TO EXCISE DUTY

- |  |    |   |    |    |  |               |
|--|----|---|----|----|--|---------------|
| 1. BEER—other than native liquor   | .. | the gallon of worts of a specific gravity of not more than 1,040° | .. | 0  | 6  | 8             |
|  |    | for each additional degree of specific gravity                    | .. | 0  | 0  | $\frac{1}{2}$ |
| 2. BISCUITS  |    |   |    |    |  |               |
| *See Note A  | .. | ..  | .. | 5  | per centum of the selling price  |               |
| 3. BLANKETS  |    |   |    |    |  |               |
| *See Note A  | .. | ..  | .. | 5  | per centum of the selling price  |               |
| 4. CEMENT  | .. | ..  | .. | 0  | 15   | 0             |
| 5. CIGARETTES  |    |   |    |    |  |               |
| (a) where the weight of one thousand cigarettes does not exceed two pounds                                     | .. | ..  | .. | 30 | per centum of the selling price  |               |
| (b) where the weight of one thousand cigarettes exceeds two pounds but does not exceed two and one-half pounds | .. | ..  | .. | 48 | per centum of the selling price where the selling price exceeds seventy shillings per thousand, and 40 per centum of the selling price in other cases. |               |

- (c) where the weight of one thousand cigarettes exceeds two and one-half pounds .. .. . 50 per centum of the selling price.

## NOTE :—

For the purpose of this Item the expression "selling price" in relation to any cigarette means—

(a) the price declared by the manufacturer to be the price, inclusive of excise duty, at which cigarettes of the same brand, weight, quality and description are ordinarily sold by him ex factory ; or

(b) if it appears to the Board that the price so declared is less than the cost of manufacture of the cigarettes together with the excise duty thereon, and all profits taken or to be taken by the manufacturer in respect thereof, then a sum which, in the opinion of the Board, is equal to such cost together with such excise duty and profits.

6. CORNED BEEF  
\*See Note A .. .. . 5 per centum of the selling price
7. ENAMELWARE  
\*See Note A .. .. . 5 per centum of the selling price
8. FOOTWEAR :
- |   |       |
|---|-------|
| (1) Wholly or mainly of leather .. the pair .. .. | 0 2 0 |
| (2) Of other material .. .. the pair .. ..        | 0 0 6 |
9. LEMONADE AND OTHER AERATED WATERS  
whether flavoured or not .. .. the gallon .. ..
- |  |       |
|--|-------|
|  | 0 0 8 |
|--|-------|
10. MATCHES :
- |   |                       |       |
|---|-----------------------|-------|
| In boxes containing 80 matches each or less .. .. . | the gross boxes .. .. | 0 6 9 |
|---|-----------------------|-------|
- For the purpose of this item four "booklets" of matches shall be regarded as a box
- Matches in boxes containing a greater quantity than 80 matches each to be charged in proportion.
11. PIECE GOODS :
- |   |                       |       |
|---|-----------------------|-------|
| (1) Knitted fabrics .. .. .                         | the pound .. ..       | 0 0 3 |
| (2) Cotton fabrics, bleached and unbleached .. .. . | the square yard .. .. | 0 0 2 |
| (3) Other .. .. .                                   | the square yard .. .. | 0 0 6 |
12. PLASTICWARE  
\*See Note A .. .. . 5 per centum of the selling price
13. SOAP AND SOAP PRODUCTS  
\*See Note A .. .. . 5 per centum of the selling price
14. SPIRITS, POTABLE,  
distilled or blended in Nigeria .. the gallon .. ..
- |  |       |
|--|-------|
|  | 7 0 0 |
|--|-------|

15. TYRES, PNEUMATIC  
of a sectional width exceeding 4" (101  
mm.) and less than 12" (305 mm.) and  
tubes and flaps therefor .. .. 10 *per centum* of the selling  
price
16. YARNS AND THREADS  
\*See Note A .. .. 10 *per centum* of the selling  
price

## NOTE A.

For the purpose of those Items (other than Item 5) where the duty is expressed as a percentage of the selling price, the expression "selling price" means—

(a) the price declared by the manufacturer to be the price, exclusive of excise duty and before deduction of trade discounts, at which the goods liable to duty are ordinarily sold by him ex factory ; or

(b) if it appears to the Board that the price so declared is less than the cost of manufacture of the goods and all profits taken or to be taken by the manufacturer in respect thereof, a sum which in the opinion of the Board is equal to such cost together with such profits.

MADE at Lagos this 7th day of March, 1964.

R. C. ONYEJEPU,  
*Acting Deputy Secretary to the  
Council of Ministers*

## EXPLANATORY NOTE

The effect of this Order is to impose excise duties on certain goods manufactured in Nigeria as follows :

- (a) on Biscuits, at 5 *per centum* of the selling price ;  
 (b) on Blankets, at 5 *per centum* of the selling price ;  
 (c) on Cement, at 15s the ton ;  
 (d) on Corned Beef, at 5 *per centum* of the selling price ;  
 (e) on Enamelware, at 5 *per centum* of the selling price ;  
 (f) on Footwear, at 2s the pair if made of leather, and 6d the pair if of other materials ;  
 (g) on Piece Goods at various rates ;  
 (h) on Plasticware, at 5 *per centum* of the selling price ;  
 (i) on Soap and Soap Products, at 5 *per centum* of the selling price ;  
 (j) on Potable Spirits, at £7-0s-0d the gallon ;  
 (k) on Pneumatic Tyres of certain sizes, at 10 *per centum* of the selling price ;  
 (l) on yarns and threads, at 10 *per centum* of the selling price.

L.N. 26 of 1964

CUSTOMS TARIFF ACT  
(No. 60 OF 1958)

Customs Tariff (Duties and Exemptions) (No. 3) Order, 1964

Commencement : 9th March, 1964

In exercise of the powers conferred by subsection (1) of section 6 of the Customs Tariff Act, 1958, the President has made the following order—

Short title  
and  
application.

Amendment  
of First  
Schedule  
to No. 60 of  
1958 L.N. 25  
of 1962.

1. This Order may be cited as the Customs Tariff (Duties and Exemptions) (No. 3) Order, 1964, and shall apply throughout the Federation.

2. The First Schedule to the Customs Tariff Act, 1958 (which relates to the import duties of Customs) as the same was replaced by the Customs Tariff (Duties and Exemptions) Order, 1962, is amended—

(a) by the deletion of sub-item (3) of item 4 and the substitution therefor of the following—

“(3) FOOTWEAR other than gaiters, leg-gings, puttees and spats :—

(a) wholly or mainly of leather ... the pair ... 0 7 6  
or *ad valorem* 33 $\frac{1}{3}$  per centum,  
whichever is the higher

(b) of other materials ... the pair ... 0 4 0  
or *ad valorem* 33 $\frac{1}{3}$  per centum,  
whichever is the higher”

(b) by the deletion of item 5 and the substitution therefor of the following—

“5. BAGS AND SACKS (other than bags loosely sewn) of textile material—

(1) Of jute with dimensions not exceeding 44" x 28" shown to the satisfaction of the Board to be imported for the packing of goods and produce manufactured, grown or processed in Nigeria ... each ... 0 0 2

(2) Other ... each ... 0 1 4  
or *ad valorem* 20 per centum,  
whichever is the higher”

(c) by the deletion of item 12 and the substitution of the following—

“12. CEMENT, Portland, and similar cements for building purposes... the ton ... 2 10 0  
or *ad valorem* 33 $\frac{1}{3}$  per centum,  
whichever is the higher”

(d) by the deletion in sub-item (3) of item 24 of the rate “33 $\frac{1}{3}$  per centum” and the substitution therefor of the rate “50 per centum”

(e) by the deletion in item 32 of the rate "33½ per centum" and the substitution therefor of the rate "50 per centum"

(f) by the deletion in sub-item (3) of item 41 of the following amount "0 0 10" and the substitution therefor of the amount "0 1 0"

(g) by the deletion of item 45 and the substitution therefor of the following—

"45. PIECE GOODS :

(1) Of cotton or natural silk or artificial silk or mixtures thereof :—

(a) Knitted fabrics	... the pound	... 0 2 6
	or <i>ad valorem</i> 33½ per centum,	whichever is the higher
(b) Velvets, velveteens, plushes and other pile fabrics	the sq. yard	... 0 3 0
	or <i>ad valorem</i> 50 per centum,	whichever is the higher
(c) Cotton fabrics, bleached and unbleached	... the sq. yard	... 0 1 0
	or <i>ad valorem</i> 25 per centum,	whichever is the higher
(d) Unbleached grey baft imported for use exclusively for the production of printed cotton fabric by a manufacturer approved in that behalf by the Minister...	... the sq. yard	... 0 0 1.8
(e) Other	... the sq. yard	... 0 1 9
	or <i>ad valorem</i> 40 per centum,	whichever is the higher

(2) Of other textile materials ... *ad valorem* 40 per centum.

For the purpose of this item 'Piece Goods' shall include handkerchiefs, headties, mufflers, sarongs, scarves and any remnants of cloth or irregular length of a greater area than one-third of a square yard, and any other articles which are capable of being used in substitution for any such articles and are in the opinion of the Board likely to be so used.

For the purpose of sub-item (1), artificial silk shall include rayon and other textile fibres prepared from natural or synthetic sources by a chemical process of solution followed by extrusion but shall not include textile fibres made of spun glass or metal."

(h) by the insertion immediately after item 45 of the following new item—

"45A. PLASTICWARE ... .. *ad valorem* 50 per centum"

(i) by the deletion in paragraph (a) of item 46 (1) of the rate "50 per centum" and the substitution therefor of the rate "66 $\frac{2}{3}$  per centum"

(j) by the deletion in sub-item (12) of item 46 of the rate "50 per centum" and the substitution therefor of the rate "66 $\frac{2}{3}$  per centum"

(k) by the deletion in item 52 of the expression "ad valorem 33 $\frac{1}{3}$  per centum" and the substitution therefor of the following ... ..

"the pound ... 0 0 9  
or ad valorem 50 per centum,  
whichever is the higher"

(l) by the deletion of item 60 and the substitution therefor of the following—

"60 TYRES—

(1) Pneumatic—

(a) Of a sectional width exceeding 4" (101 mm.) and less than 12" (305 mm.) and tubes and flaps therefor but excluding

(i) tyres pneumatic designed for agricultural tractors, agricultural and industrial implements, earth movers, graders and similar machines, and tubes and flaps therefor, and so invoiced ;

(ii) tyres pneumatic designed for aircraft and tubes therefor and so invoiced ... ..

the pound weight 0 3 6

(b) Other, unless specifically exempted under item 67A of the Second Schedule—

(i) of a sectional width exceeding 1 $\frac{1}{2}$ " and tubes and flaps therefor ... ..

ad valorem 33 $\frac{1}{3}$  per centum

(ii) of a sectional width not exceeding 1 $\frac{1}{2}$ " and tubes therefor ... ..

ad valorem 20 per centum

(2) Other ... ..

ad valorem 20 per centum

(m) by the deletion in sub-item (3) of item 63 of the amount "0 0 4" and the substitution thereof of the amount "0 1 2"

3. The Second Schedule to the Customs Tariff Act, 1958 (which relates to exemptions from import duties of Customs) as the same was replaced by the Customs Tariff (Duties and Exemptions) Order, 1959, is amended—

Amendment  
of Second  
Schedule to  
No. 60 of  
1958 L.N. 84  
of 1959.

(a) by the renumbering of item "27A" as item "27B" and the insertion of the following new item—

"27A. FLAVOURING CONCENTRATES,  
blending agents and neutral blending alcohol imported for use  
exclusively for the production of potable spirits by a distiller  
approved in that behalf by the Minister"

(b) by the deletion in item 65 of the word "Stationery"

MADE at Lagos this 7th day of March, 1964.

R. C. ONYEJEPU,  
*Acting Deputy Secretary*  
to the Council of Ministers

#### EXPLANATORY NOTE

This Order has the following effects :—

(a) it increases the import duty—

- on footwear of leather from 3s-6d the pair to 7s-6d the pair, and of other material from 3s-6d the pair to 4s-0d the pair ;
- on bags and sacks, other than those made of jute, from 2d to 1s-4d with an alternative *ad valorem* duty of 20 per centum ;
- on cement from £1-10s-0d to £2-10s-0d per ton, and the alternative *ad valorem* duty from 20 per centum to 33½ per centum ;
- on mattresses from 33½ per centum *ad valorem* to 50 per centum *ad valorem* ;
- on household utensils of metal from 33½ per centum *ad valorem* to 50 per centum *ad valorem* ;
- on lubricating oils from 10d to 1s-0d per gallon ;
- on knitted fabrics of cotton or silk from 2s-3d to 2s-6d per pound, and the alternative *ad valorem* duty from 25 per centum to 33½ per centum ;
- on certain other cotton or silk piece goods from 1s-4d to 1s-9d per square yard and the alternative *ad valorem* duty from 33½ per centum to 40 per centum ;
- on other textile piece goods from 33½ per centum *ad valorem* to 40 per centum *ad valorem* ;
- on plasticware to 50 per centum *ad valorem* ;
- on biscuits from 50 per centum *ad valorem* to 66⅔ per centum *ad valorem* ;

on meat including poultry and game from 50 *per centum ad valorem* to 66⅔ *per centum ad valorem* ;

on soap and soap products from 33⅓ *per centum ad valorem* to 50 *per centum ad valorem* with an alternative rate of duty of 9*d* per pound ;

on tyres of certain types and sizes from 33⅓ *per centum ad valorem* to 3*s*-6*d* the pound weight.

on yarns and threads of cotton and/or artificial silk, other than those for sewing, darning, crocheting and embroidery, from 4*d* the pound to 1*s*-2*d* the pound.

(b) it exempts from import duty—

Flavouring concentrates, blending agents and neutral blending alcohol imported by an approved distiller.

(c) it revokes the exemption from import duty of stationery imported for educational purposes by schools etc.

F10251/S. 86

L.N. 29 of 1964

## LABOUR CODE ACT (CHAPTER 91)

**The Labour Code (Trade Union Contributions) Order, 1964***Commencement : 1st March, 1964*

In exercise of the powers conferred by section 27A (2) of the Labour Code Act, and of all other powers enabling me in that behalf, I hereby make the following Order :—

1. This Order may be cited as the Labour Code (Trade Union Contributions) Order, 1964 and shall be of Federal application. Citation and application.

2. The trade union specified in the first column of the Schedule is hereby approved for the purpose of subsection (1) of section 27A of the Labour Code Act with effect from the date specified in the second column of the Schedule. Trade Unions approved by Minister pursuant to section 27A (2), Cap. 91. Schedule.

SCHEDULE		Section 2
<i>Name of Trade Union</i>		<i>Date</i>
Nigeria Oil, Chemical and Allied Workers' Union .. .. .		1-3-64
Nigerian Tobacco General Workers' Union .. .. .		1-3-64
Deck Staff Union Inland Waterways Department .. .. .		1-3-64
Nigerian Motor Drivers' Union and Allied Transport Workers ..		1-3-64
Eastern Nigeria Internal Revenue Staff Association .. .. .		1-3-64
University College Hospital Workers' Union .. .. .		1-3-64
C.F.A.O. and Associated Companies African Workers' Union of Nigeria .. .. .		1-3-64

DATED at Lagos this 27th day of February, 1964.

ML Ic/102/2

J. M. JOHNSON,  
*Federal Minister of Labour*

L.N. 30 of 1964

## LABOUR CODE ACT (CHAPTER 91)

**The Labour Code (Trade Union Contributions) Order, 1964***Commencement : 1st February, 1964*

In exercise of the powers conferred by Section 27A (2) of the Labour Code Act, and of all other powers enabling me in that behalf, I hereby make the following Order :—

1. This Order may be cited as the Labour Code (Trade Union Contributions) Order, 1964 and shall be of Federal application. Citation and application.

2. The trade union specified in the first column of the Schedule is hereby approved for the purpose of subsection (1) of Section 27A of the Labour Code Act with effect from the date specified in the second column of the Schedule. Trade Unions approved by Minister pursuant to Section 27A (2), Cap. 91. Schedule.

## SCHEDULE

## Section 2

<i>Name of Trade Union</i>	<i>Date</i>
Survey Technical Field Staff Union of Nigeria .. ..	1-2-64
Nigerian Produce Marketing Co. Workers' Union .. ..	1-2-64
Western Nigeria Public Utility Technical and General Workers' Union .. ..	1-2-64
Pharmaceutical Union of Northern Nigeria .. ..	1-2-64
Eastern Nigeria Messengers' Union .. ..	1-2-64

DATED at Lagos this 24th day of January, 1964.

J. M. JOHNSON,  
*Federal Minister of Labour*

MI. Ic/102/2

L.N. 31 of 1964

LAGOS LOCAL GOVERNMENT ACT, 1959

**Municipal Transport Board Regulations, 1964**

*Commencement : 12th March, 1964*

**In exercise of the powers conferred by paragraph (c) of section 9A of the Lagos Local Government Act, 1959, the President hereby makes the following regulations :—**

Short title.

Interpreta-  
tion.

1. These regulations may be cited as the Municipal Transport Board Regulations, 1964.

2. In these regulations, unless the context otherwise requires—

“Board” means the Municipal Transport Board established under paragraph (1) of regulation 3 ;

“Chairman” means the Chairman of the Board elected under regulation 6.

“Council” means the Lagos City Council established under the provisions of section 10 of the Lagos Local Government Act, 1959 ;

“General-Manager” means the General-Manager of the Transport Service appointed by the Council under subsection (2) of Section 68 of the Act ;

“City Treasurer” means the City Treasurer of the Council appointed under subsection (1) of Section 68 of the Act ;

“the Act” means the Lagos Local Government Act, 1959 ;

“Town Clerk” means the town clerk of the Council appointed under subsection (1) of Section 68 of the Act ;

“Transport service” means the transport service provided by the Council with the approval of the Minister under subsection (8) of Section 141 of the Act.

Establish-  
ment of  
the Board.

3.—(1) There shall be established for the purpose of administering the transport service a board to be known as the Municipal Transport Board.

(2) The Chairman on behalf of the Council may, for the purposes of the transport service, enter into contracts and acquire movable and immovable property which shall be vested in the Council.

4. The Board shall consist of six members appointed by the Minister in the following manner, that is to say—

Members-  
ship of  
the Board.

(a) five members shall be appointed from among members of the Council ; and

(b) the remaining one member shall be appointed from persons appearing to the Minister to have considerable business experience.

5.—(1) Members of the Board shall hold office for such period not exceeding three years as may be determined at the time of their respective appointments.

Tenure of  
office.

(2) A member shall vacate his office, notwithstanding that his term of office has not expired if—

(a) he is removed from office at any time by the Minister ; or

(b) he gives notice of his resignation to the Minister ; or

(c) the Board gives notice to the Minister stating that the member has—

(i) become incapable by reason of mental or physical infirmity of discharging his duties ; or

(ii) become unfit for membership by reason of his having contravened the provisions of regulation 13 (1) ; or

(iii) been absent from three consecutive meetings of the Board without the leave of the Board ; or

(d) he is convicted by a court of record in Nigeria of an offence involving dishonesty and the conviction still stands at a time when no appeal or further appeal is pending, or may (without extension of time) be brought, in connection with the conviction.

(3) As soon as may be after a person ceases to hold office as a member, the Minister shall fill the vacancy.

(4) A person ceasing to be member otherwise than by virtue of subparagraph (c) (i) or (ii) and (d) of paragraph (2) of this regulation shall be eligible for re-appointment as a member.

6. The Minister shall elect a member to be the Chairman for such a period as the Minister may determine, so however that a Chairman who ceases to be a member shall cease to be Chairman.

Election  
of  
Chairman.

7. The Board shall pay to its Chairman and members such remuneration, fees or allowances for expenses as may be determined by the Minister.

Remune-  
ration of  
members.

8. The quorum of the Board shall be three.

Quorum.

9.—(1) The Board shall ordinarily meet at least once a month for the despatch of business at such place as the Chairman may from time to time appoint.

Meetings of  
the Board.

(2) A special meeting of the Board may be called at any time with the approval of the Chairman.

(3) All meetings of the Board shall be summoned by the General Manager.

(4) At any meeting of the Board the Chairman shall preside but in his absence the Board shall appoint one of the members present to preside.

(5) Every question which comes before the Board at any meeting shall be decided by a majority of the votes of the members present and voting.

(6) The Chairman or the member presiding in his absence at any meeting shall have a vote and in the case of an equality of votes, a second or casting vote.

(7) The Town Clerk, the City Treasurer and the General-Manager shall be in attendance at all meetings of the Board and the Board may request any officer or servant of the Council to attend any of its meetings.

Duties of the Board.

10. Subject to the provisions of the Lagos Local Government Act, 1959, and of these regulations, it shall be the responsibility of the Board to determine the policy governing the transport service, and to provide within the city of Lagos and the adjoining districts such transport service by the use of omnibuses and other appropriate vehicles and generally to administer the said service.

Functions of the General-Manager.

11—(1) The transport service shall be under the immediate control and management of the General-Manager who shall, in the performance of his duties, be responsible to the Board.

(2) The Board shall delegate to the General-Manager such of its functions under these regulations as are necessary to enable him to transact effectively the day-to-day business of the Board of every kind whatsoever and in particular, and without prejudice to the generality of the foregoing, shall delegate to him the power to exercise supervision and control over the acts and proceedings of all officers and servants of the Council in matters of executive administration of the transport service and in matters concerning the accounts and record of the transport service.

(3) Subject to the provisions of sections 74 and 82 of the Act and of any general restrictions which may be imposed by the Council, the Council may delegate to the General-Manager the power to dispose of all questions relating to the service of the said officers and servants and their pay, privileges, and allowances.

(4) The General-Manager may unless otherwise directed by the Board delegate to any officer or servant of the Council any of the functions delegated to him by the Board.

Annual report and returns.

12.—(1) The Board shall, as soon as possible after the end of each financial year and in any case not later than the end of July of each year, report to the Council on the activities of the Board during the past financial year.

(2) The Council shall, as soon as may be after receipt of any annual report, transmit such report to the Minister.

(3) The Board shall furnish to the Council such financial and statistical returns as it may from time to time require.

Disclosure of interest.

13—(1) If a member of the Board is directly or indirectly interested in any contract, proposed contractor or other matter and is present at a meeting of the Board at which the contract, proposed contract or other matter is the subject of consideration, he shall, at the meeting and as soon as practicable after the commencement thereof, disclose the fact and shall not take part in the consideration, or discussion of, or vote on, any question in respect of the contract or other matter.

(2) A disclosure of interest made under this regulation shall be recorded in the minutes of the meeting at which it is made.

14. The validity of any proceedings of the Board shall not be affected by any vacancy in the membership of the Board or by any defect in the appointment of a member or by reason that a person not entitled to do so took part in the proceedings.

Validity of  
proceed-  
ings.

DATED the 25th day of February, 1964.

R. C. ONYEJEPU,  
*Acting Deputy Secretary to the  
Council of Ministers*

EXPLANATORY NOTE

The purpose of these Regulations is to establish the Municipal Transport Board for the purpose of administering the transport service provided by the Lagos City Council.

L0071/S. 3

---

L.N. 32 of 1964

MERCHANT SHIPPING ACT, 1962  
(1962, No. 30)

MERCHANT SHIPPING (MANNING) REGULATIONS, 1963

**Appointed Day Notice**

In exercise of the powers conferred by regulation 1 (i) of the Merchant Shipping (Manning) Regulations, 1963 and of all other powers enabling me in that behalf, I hereby appoint the 12th day of March, 1964 as the date on which the said Act shall come into force.

DATED at Lagos this 4th day of March, 1964.

T1926/S. 2

R. A. NJOKU,  
*Minister of Transport*



The following Bill, which will in due course be presented to Parliament for enactment, is published for general information.

## THE REMOVAL OF VEHICLES, ETC. (LAGOS) BILL

### EXPLANATORY MEMORANDUM

This Bill makes fresh provision for the removal of motor vehicles left on highways in Lagos in breach of the parking regulations. It requires the Lagos City Council to provide the means of removing these vehicles and the places in which they are to be kept until they are claimed or, where they remain unclaimed for a substantial period, until they are disposed of in accordance with the directions of the High Court.

The Bill also provides for the arrest without a warrant of persons in charge of taxis and other vehicles used for transporting members of the public where the use is not authorised by the appropriate permit.

MUSA YAR'ADUA,  
*Minister of Lagos Affairs*

## THE REMOVAL OF VEHICLES, ETC. (LAGOS) BILL

### ARRANGEMENT OF CLAUSES

*Clause*

- |   |   |
|---|---|
| 1. Removal of vehicles from highways.                       | 5. Arrest without warrant of persons in charge of vehicles unlawfully used as taxis, etc. |
| 2. Provision of removed vehicle parks, etc. by the Council. | 6. Interpretation, etc.   |
| 3. Reclaiming of removed vehicles.                          | 7. Short title, extent and commencement.  |
| 4. Disposal by court of unreclaimed vehicles, etc.          |   |



## A BILL

FOR

AN ACT TO PROVIDE FOR THE REMOVAL AND DISPOSAL OF VEHICLES LEFT ON HIGHWAYS ; FOR THE ARREST WITHOUT WARRANT OF PERSONS IN CHARGE OF VEHICLES APPEARING TO BE USED UNLAWFULLY AS HACKNEY OR STAGE CARRIAGES ; AND FOR PURPOSES CONNECTED WITH THE MATTERS AFORESAID.

[See section 7 (2)]

Commence-  
ment.

BE IT ENACTED by the Legislature of the Federation of Nigeria in this present Parliament assembled and by the authority of the same as follows :

1. — (1) Where a motor vehicle is stationary on a highway, any police officer of or above the rank of inspector may, subject to subsection (3) of this section, cause the vehicle to be removed to a removed vehicle park if—
- Removal of  
vehicles from  
highways.
- (a) he has reasonable grounds for believing that the presence of the vehicle on the highway is in contravention of provisions of an enactment relating to the parking of vehicles ; and
- (b) he is of the opinion that the contravention should be investigated ; and
- (c) he has reasonable grounds for believing either—
- (i) that the vehicle is not in a condition in which it can be moved under its own power ; or
- (ii) that no person authorised to drive the vehicle is in or in the immediate vicinity of the vehicle.
- (2) A person acting in pursuance of the foregoing subsection as respects any vehicle may use such force as may be reasonably necessary for the purpose of removing the vehicle or of gaining access to any part of it in order to facilitate the removal of the vehicle.
- (3) Where a police officer has given instructions for the removal of a vehicle in pursuance of subsection (1) of this section but—
- (a) the vehicle has not been moved from its position in pursuance of the instructions ; and
- (b) a person claiming to be entitled to the custody of the vehicle gives to any person proposing to carry out the instructions an undertaking to remove it forthwith,
- the instructions shall cease to have effect if the undertaking is fulfilled ; but except as provided by the foregoing provisions of this subsection a person claiming to be entitled to the custody of a vehicle in respect of which such instructions have been given shall not be entitled to recover the vehicle otherwise than in pursuance of the following provisions of this Act.

Provision of removed vehicle parks, etc. by the Council.

2.—(1) It shall be the duty of the Council—

(a) to provide and maintain places in Lagos to which vehicles may be removed in pursuance of the foregoing section (in this Act referred to as “removed vehicle parks”), and to secure that an officer in charge of each park is at all times present in the park when removed vehicles are in it; 5

(b) to provide suitable facilities (including equipment and persons to operate it) for the removal of vehicles in pursuance of the foregoing section;

(c) to make reasonable arrangements for the safe-custody of removed vehicles while they are in removed vehicle parks; 10

(d) to provide and maintain at the principal offices of the Council a record containing particulars of each removed vehicle and its contents and specifying the date of its removal, the park in which it is situated and whether an application in respect of the vehicle has been made to the court in pursuance of subsection (3) of section four of this Act; and 15

(e) to keep the record open during normal office hours for inspection free of charge by members of the public.

(2) The Council shall not be under any duty to protect removed vehicles otherwise than as mentioned in paragraph (c) of the foregoing subsection, and in particular shall not be under a duty to protect removed vehicles from damage attributable to sun, rain, wind or other physical conditions. 20

3.—(1) A person who tenders to the official in charge of a removed vehicle park— 25

(a) such evidence as may be prescribed of his entitlement to the custody of a removed vehicle which is in the park; and

(b) the appropriate charges in respect of the vehicle and a receipt for the vehicle in the prescribed form, 30

shall, subject to the provisions of subsection (3) of this section and of any order under this Act previously made by the court, be entitled, on demand at the park at any time between the hours of eight o'clock in the morning and six o'clock in the following evening on any weekday (other than a public holiday) and with consent given on behalf of the Council at any other time, to have the vehicle delivered up to him at the park. 35

(2) In the foregoing subsection—

“appropriate charges”, in relation to a removed vehicle of any class, means such sum as the Minister may by order specify as respects vehicles of that class; and 40

“prescribed” means prescribed by regulations made by the Minister; and the Minister shall so exercise his powers to make orders under this subsection as to secure that the sums specified by the orders will, in his opinion, not in the aggregate exceed the sums required, taking one year with another, to reimburse to the Council the cost of performing the functions imposed on the Council by this Act. 45

Reclaiming of removed vehicles.

(3) Except so far as the court otherwise orders, subsection (1) of this section shall not apply in relation to a removed vehicle as respects which an application to the court has been made in pursuance of this Act.

4.—(1) If a removed vehicle is not disposed of in accordance with this Act within the period of one month beginning with the date on which it is removed in pursuance of this Act, the Council shall, as soon as reasonably practicable after the expiration of that period, cause to be published in two separate issues of the Gazette of the Federation, and of each of two daily newspapers circulating in Lagos, a notice containing particulars of the vehicle and stating that, unless the vehicle is otherwise disposed of in accordance with this Act before the expiration of the period of two months beginning with the date of the Gazette in which the notice is first published, the Council proposes to apply to the court for an order for the forfeiture of the vehicle to the Council.

Disposal by court of unclaimed vehicles, etc.

(2) A person claiming to be entitled—

(a) to the benefit of a charge or lien on a removed vehicle apart from its contents; or

(b) to, or to the benefit of a charge or lien on, any contents of a removed vehicle,

may at any time before the making of an application in respect of the vehicle in pursuance of the next following subsection, apply to the court for an order protecting his interest in the vehicle or the contents, as the case may be; and on any such application the court may make such order as it considers just, including an order vesting the vehicle or its contents in any person on such terms as the court thinks fit.

(3) If, on an application in respect of a removed vehicle made by the Council after the expiration of the period of two months mentioned in subsection (1) of this section, the court is satisfied—

(a) that notices in accordance with that subsection have been published in respect of the vehicle; and

(b) that immediately before the removal of the vehicle in pursuance of this Act its presence on the highway from which it was removed was in contravention of provisions of an enactment relating to the parking of vehicles; and

(c) that no person claiming to be entitled to the custody of the vehicle or to any of its contents has taken the steps required by rules of court for the purpose of enabling him to oppose the application, or that every such person who has taken those steps has failed to establish his claim,

the court may order the forfeiture of the vehicle to the Council; and where such an order is made in respect of a removed vehicle, the vehicle (including its contents) shall, subject to the provisions of any relevant order made in pursuance of the last foregoing subsection, vest in the Council free from encumbrances, and the Council may retain it or dispose of it as the Council thinks fit.

(4) Where, on an application made to the court in pursuance of the last foregoing subsection in respect of a removed vehicle, any such person as is mentioned in paragraph (c) of that subsection establishes his claim to be entitled to the custody of the vehicle or to any of its contents, the court may make such order as it considers just, including an order vesting the vehicle or its contents in any person on such terms as the court thinks fit.

*Removal of Vehicles, etc. (Lagos)*

on to the court under this section shall be made  
les of court.

in addition to any other power of arrest exercisable by a  
police officer may arrest without a warrant a person  
of the officer, acts as the driver of a motor vehicle 5  
present in such circumstances that the officer reason-  
ably believes that the vehicle is being used in contravention of any  
of the provisions of any law relating to the use of vehicles as  
prescribed in the meaning of the Road Traffic Act.

Act the following expressions have the meanings 10  
they respectively unless the context otherwise

means—

"Council" means the Lagos City Council ;

"Court" means the High Court of Lagos ;

"Section" means the same meaning as in section twenty-seven of 15  
Act, 1964 ;

"Minister" means the Minister of the government of the  
territory responsible for relations with the Council ;

"Road Traffic Act" has the same meaning as in the Road Traffic Act ;

"Removed" means a vehicle removed in pursuance of section 20  
and

"Park" has the meaning assigned to it by paragraph  
(1) of section two of this Act.

and, references to a vehicle include references to any  
thing attached to the vehicle and, except where the 25  
word appears and except in paragraph (a) of subsection (1)  
references to the contents of the vehicle.

This Act shall be construed as affecting the liability  
of a person convicted of or punished for an offence.

This Act may be cited as the Removal of Vehicles, etc. 30  
and shall apply to the Federal territory only.

It shall come into force on such day as the Minister

The following Bill, which will in due course be presented to Parliament for enactment, is published for general information.

## DEFENCE INDUSTRIES CORPORATION OF NIGERIA BILL

### EXPLANATORY MEMORANDUM

This Bill seeks to establish ordnance factories to meet the defence requirements of Nigeria, and if approved a factory may be expected to go into production towards the end of this year. In order to regulate the organisation and administration of the factories, this Bill seeks to establish a Defence Industries Corporation under the overall control of the Minister of Defence; and it provides for the composition of such Corporation, and for its functions and powers and the responsibility of the Minister of Defence. Other provisions of the Bill relate to financial administration and auditing of the accounts of the Corporation.

ALHAJI MUHAMMADU RIBADU,  
*Minister of Defence*

(898)

## DEFENCE INDUSTRIES CORPORATION OF NIGERIA BILL

### ARRANGEMENT OF CLAUSES

Clause	
1. Defence Industries Corporation of Nigeria.	8. Interest of member to be disclosed on any contract.
2. Corporation to act under directions of Minister.	9. Restricted application of Firearms Act.
3. Appointment and powers of general manager.	10. Application of Factories Act.
4. Staff.	11. Taking part in any strike an offence.
5. Operation of ordnance factories.	12. Regulations.
6. Funds of corporation.	13. Interpretation.
7. Accounts and records to be kept.	14. Short title, application and commencement.
	Schedule—Constitution, etc., of the corporation.

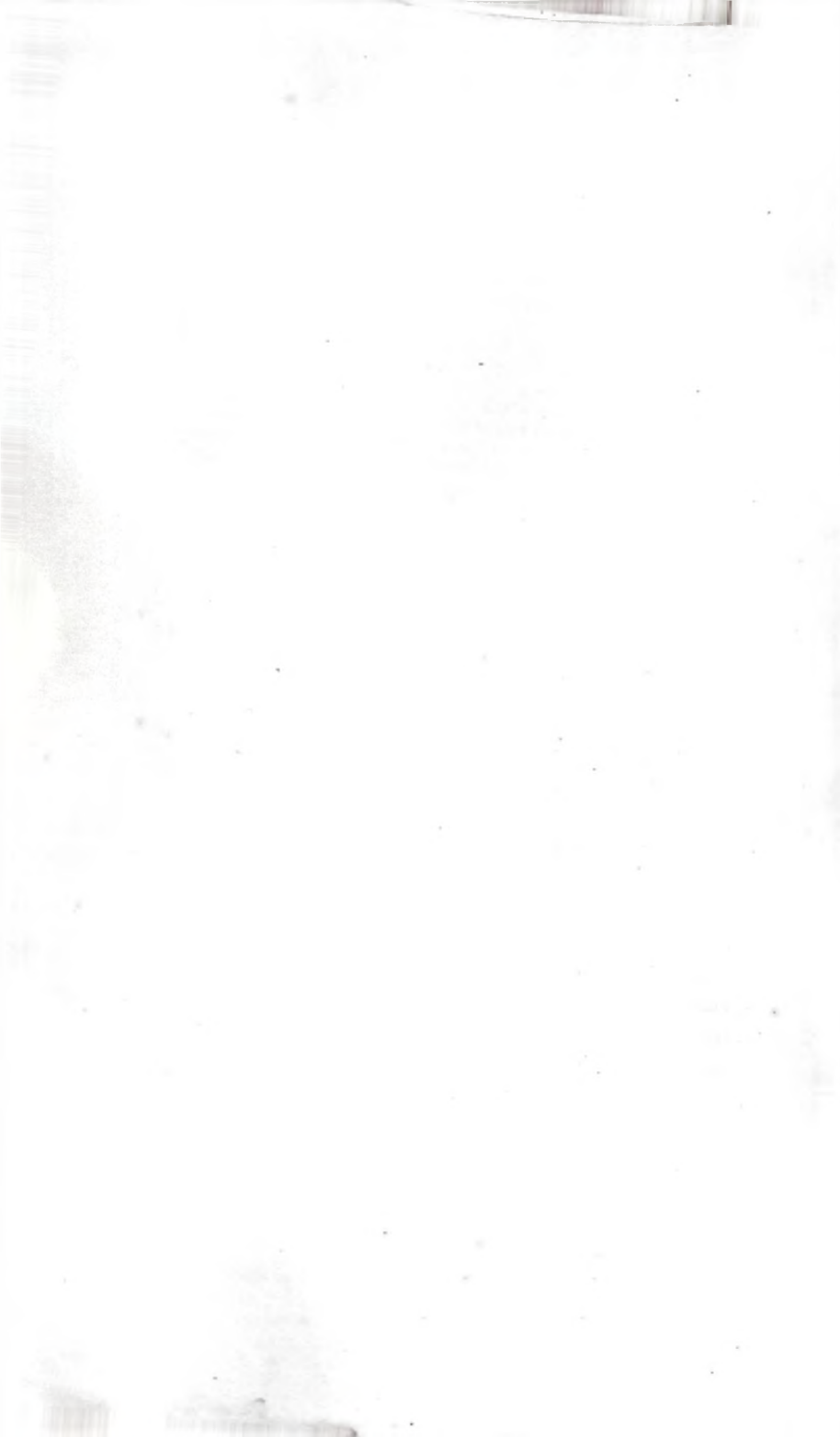

# A BILL

FOR

AN ACT TO ESTABLISH A CORPORATION TO OPERATE, MAINTAIN AND CONTROL FACTORIES FOR THE MANUFACTURE, STORAGE AND DISPOSAL OF ORDNANCE AND ANCILLARY STORES AND MATERIEL ; TO PROVIDE FOR ALTERATION IN ANY SUCH MANUFACTURE, STORAGE AND DISPOSAL AT ANY TIME ; AND FOR RELATED MATTERS.

[Section 14 (2)]

Commence-  
ment.

BE IT ENACTED by the Legislature of the Federation of Nigeria in this present Parliament assembled and by the authority of the same as follows :—

1.-(1) On a day to be appointed by order of the Minister in the Gazette (in this Act referred to as "the appointed day") the assets of the Government of the Federation in any land or any building thereon erected or in course of erection as an ordnance factory (as hereafter referred to in this section) and so designated in such order as to sufficiently identify it shall vest in and be operated, maintained and controlled by the corporation hereafter mentioned.

Defence  
Industries  
Corporation  
of Nigeria.

(2) There shall be established with effect from the appointed day, a corporation to be known as the Defence Industries Corporation of Nigeria (in this Act referred to as "the corporation") which shall be a body corporate and be charged with—

(a) the operation, maintenance and control in such place or places in Nigeria as the Minister may require, of factories (in this Act referred to as "ordnance factories") for the manufacture, storage and disposal of ordnance and ancillary stores and materiel intended for or capable of being used by the armed forces and such other forces or persons as the Council of Ministers may authorise, and vested in the corporation under subsection (1) of this section or hereafter erected on land the location of which is approved by the Minister ;

(b) the inspection or testing, as the case may be, of ordnance and materiel ;

(c) such other duties as may be prescribed under this Act.

(3) The provision of the schedule to this Act shall have effect as regards the membership, proceedings and contractual powers of the corporation.

2.—(1) The Minister may for all or any of the purposes of this Act initiate or approve policy ; and accordingly the Minister may give to the corporation directions of a general or special nature as to—

Corporation  
to act  
under  
directions  
of  
Minister.

(a) the manner in which the corporation is to exercise its powers, or

(b) the payment of allowances to members of the corporation,

and it shall be the duty of the corporation to give effect to any such directions.

(2) No policy initiated by the corporation shall be implemented without prior reference to and approval by the Minister, and the Minister may, if he thinks it necessary, consult with the corporation before approving any policy ; but the question whether there was any such consultation or what was decided shall not be inquired into by any court.

Appointment and powers of general manager.

3.—(1) The Minister may from time to time appoint a fit person to be general manager of the corporation. The general manager shall be the chief executive officer of the corporation, and as and when directed so to do, he shall give to the corporation such information as to the activities of the corporation as the Minister or the corporation may reasonably require. 5

(2) The corporation may delegate to the general manager all or any of the powers mentioned in this section ; and subject thereto the general manager may authorise programmes and plans for giving effect to policy approved by the Minister or to any direction or recommendation of the corporation as to any ordnance factory in Nigeria or as to staff training therein. 10

(3) The fact that any such powers have been delegated to the general manager shall not preclude the corporation itself from exercising them in any special case. 15

(4) The powers mentioned in this section are—

(a) the executive control over other servants of the corporation,

(b) the supervision of accounts and records,

(c) the preparation for approval of sectional programmes and plans necessary to carry into effect approved policy or any directions of the corporation, 20

(d) the interpretation of such policy to other servants of the corporation where necessary,

(e) the making of any staff recommendations to the corporation,

(f) the establishment of organisational structures and definition of responsibilities. 25

Staff.

4.—(1) Subject to the provisions of this section, the corporation may appoint such persons as members of its staff as it considers necessary and may approve conditions of service, including provision for the payment of pensions : 30

Provided that no pension scheme shall be put into operation without the prior approval in writing of the Federal Minister charged with responsibility for pensions.

(2) The secretary of the corporation shall be appointed subject to the approval of the Minister, and shall keep the records and conduct correspondence and perform such other duties of a clerical nature as the corporation may from time to time direct or require. 35

(3) The general manager and other members of the staff of the corporation shall, unless exempted by the Minister, take such oaths as to secrecy and other matters as the Minister may from time to time direct. 40

(4) If the Minister deems it expedient that any staff vacancy should be filled by a person holding office in the public service of the federation he shall inform the Federal Minister charged with responsibility for establishments to that effect, and thereafter the public service commission of the federation may fill the vacancy by way of secondment or transfer. 45

(5) Where any member of the public service is seconded to the staff of the corporation, he shall be notified of the terms and conditions thereof, and any such secondment shall be without prejudice to any pension rights, which, but for the secondment, would still accrue or become due, owing and payable to such public servant. Any person 50

seconded to such staff may elect to be transferred to the staff, and any previous service in the public service of the federation shall count as service for the purposes of any pension subsequently payable.

- 5 (7) Where any member of the public service is transferred to the corporation, his former service with the public service of the federation shall be taken into account when computing any requirements of the Pensions Act, and where the Federal Minister of Pensions approves, the said Minister shall do all things necessary and that Act shall be construed and have effect as if the service with the corporation thereafter  
10 of the person so transferred were service with such public service of the federation.

Cap. 147.

- 5.—(1) The corporation shall operate any ordnance factory under its control on a sound commercial basis and so as to fill the normal defence requirements of the armed forces; and shall plan its activities  
15 so far as may be necessary to meet other needs from time to time prescribed by the Council of Ministers.

Operation of ordnance factories.

- (2) If there is any surplus capacity in the operation of an ordnance factory, the general manager shall so advise the Minister through the corporation and the Minister with the approval of the Council of  
20 Ministers may direct that any such surplus capacity may be adapted where necessary and be used towards meeting the civilian needs of Nigeria.

- (3) Where the corporation undertakes the inspection and testing of ordnance and materiel for use by the armed forces, it shall recommend adoption or rejection as the case may be to the Minister, and the Minister  
25 shall give any directions necessary in the circumstances.

- (4) The corporation may on behalf of any of the governments of Nigeria, test and inspect any substance, material, machine or other thing whatsoever intended for or capable of being used by the armed forces, whether or not it is thereafter so used, or is rejected.

- 30 (5) For all or any of the purposes of this section, the corporation may, in its discretion, institute a system of technical standards of classes of materials, structures and machines.

6. The Funds of the corporation shall consist of—

- 35 (a) such sum as may be required for the completion of any building erected as an ordnance factory and taken over on the appointed day;  
(b) moneys from time to time voted by Parliament,  
(c) moneys received from the process of any sale or hire.

Funds of corporation.

- 7.—(1) The corporation shall keep proper accounts and other records and shall not later than the thirtieth day of September in each  
40 year prepare estimates of receipts and expenditure of the corporation for the next ensuing financial year and shall submit the estimates for the approval of the Minister.

Accounts and records to be kept.

- (2) If the estimated expenditure approved for a financial year is exceeded without the prior approval in writing of the Minister, members  
45 of the corporation shall be liable to a surcharge on salary or allowances as the case may be, at the instigation of the Director of Audit.

- (3) Separate accounts shall be kept in relation to moneys received and expended by the corporation in connection with the manufacture, production, sale and letting on hire of any equipment authorised for  
50 release under this Act.

- (4) The accounts of the corporation shall be audited by auditors to be appointed annually by the corporation with the approval of the

Minister ; and as soon as may be after each audit the corporation shall furnish a copy of the statement of accounts to the Minister together with a copy of any report made by the auditors on that statement or on the accounts of the corporation.

Interest of member to be disclosed on any contract.

8.—(1) A member of the corporation who has any interest in any company or concern with which the corporation proposes to make any contract or any interest in such contract, shall disclose to the corporation the fact of such interest and the nature thereof, and such disclosure shall be recorded in the minutes of the corporation. 5

(2) A member having any such interest shall take no part in any deliberation or decision of the corporation relating to such contract. 10

Restricted application of Firearms Act. Cap. 69.

9.—(1) Nothing in the Firearms Act shall be construed to preclude the importation by the corporation of any firearm as therein defined or such firearm or ammunition in an ordnance factory. 15

(2) Every ordnance factory under the control of the corporation shall, for the purposes of the Firearms Act be deemed to have been recognised as a public armoury without further authority than this Act ; but firearms and ammunition therein may be held by the corporation for such period as it thinks fit, anything in the Firearms Act to the contrary notwithstanding. 20

Application of Factories Act. Cap. 66.

10. In the application of the Factories Act, it shall not be necessary to register any ordnance factory ; and the powers of entry and inspection shall be exercisable during the hours of daylight and then only at such time or times as may be convenient to the general manager, after taking into consideration the nature of the work, or the part of the ordnance factory to be inspected. 25

Taking part in any strike offence.

11. It shall be an offence punishable on conviction by a fine of not less than fifty pounds or more than one hundred pounds or by imprisonment for a term of one month, or by both, for any person employed by the corporation in any capacity, and whether or not a member of a trade union to engage, or take part, in any strike. 30

Regulations.

12.—(1) The Minister may make regulations generally for the purposes of this Act.

(2) Notwithstanding the provisions of subsection (1) of this section, the corporation may, with the approval of the Minister, make regulations— 35

(a) for prescribing the terms and conditions of service of the general manager and other servants of the corporation ;

(b) for regulating the procedure in the activities of the corporation other than at meetings ; 40

(c) for prescribing danger zones within or outside an ordnance factory.

Interpretation.

13. In this Act unless the context otherwise requires—

“armed forces” means the army, navy and air force of Nigeria ;

“building” includes fixtures, and any plant, machinery and office furniture supplied or to be supplied under any contract, and whether or not affixed or intended to be affixed to the land ; 45

“the corporation” means the Defence Industries Corporation of Nigeria established under this Act ;

“materiel” includes any armament, ammunition and equipment ; 50

“the Minister” means the Federal Minister charged with responsibility for defence ;

“ordnance factory” means any public establishment for the manufacture, storage and disposal of ordnance and ancillary stores and materiel intended for or capable of being used by the armed forces, and includes the manufacture of any other thing that may be approved under this Act.

14.—(1) This Act may be cited as the Defence Industries Corporation of Nigeria Act, 1964 and shall apply throughout the Federation.

(2) This Act shall, as to sections one and six, come into operation on the appointed day which may, in the discretion of the Minister, be the date of its passing; and subject thereto, the provisions of this Act shall commence on a day to be appointed after the passing of this Act, and whether by the same or any further order of the Minister.

Short title,  
application  
and  
commence-  
ment.

---

### SCHEDULE

### Section 1 (3)

#### *Constitution, etc., of the Corporation*

15 1.—(1) The corporation shall be a body corporate with perpetual succession and a common seal.

(2) Membership of the corporation shall consist of nine fit persons appointed by the Minister of whom—

20 (a) the chairman shall be the permanent secretary of the Ministry of Defence,

(b) the general manager who shall be deputy chairman; and the following other members so appointed—

(i) one on the recommendation of the Accountant-General of the Federation,

25 (ii) one from the Ministry of Commerce and Industry on the recommendation of the Federal Minister responsible therefor,

(iii) one from the army on the recommendation of the army council,

(iv) one from the navy on the recommendation of the navy board,

30 (v) one from the air force on the recommendation of the air council,

(vi) one from the Nigeria police force on the recommendation of the Inspector-General of Police,

(vii) the chief accountant in the Ministry of Defence.

35 (3) If the chairman or the deputy chairman is unable to attend, the Minister shall in writing appoint the chairman for any particular meeting.

(4) Subject to the foregoing provisions of this paragraph, where any person appointed by virtue of office or otherwise is absent or unable for any reason to attend meetings he may by writing under his hand addressed to the chairman nominate some other person to attend; and any such nominee shall if approved by the chairman and for the purposes of any meeting of the corporation attended by the nominee, be deemed to be a member of the corporation.

45 (5) A member shall hold office for such period and on such terms as may be specified in the relevant instrument of appointment, but

if directed in writing by the Minister shall vacate office anything to the contrary in the instrument notwithstanding; and any person so required to vacate his office shall cease to be a member of the corporation.

2.—(1) The first meeting of the corporation shall be convened and held at such place as the Minister may nominate, and any subsequent meeting shall be convened by the chairman. 5

(2) At any meeting the general manager shall have a deliberative vote, but if at a meeting matters touching or concerning him are being discussed the general manager shall not vote, and if in the chair he shall vacate it in favour of any member appointed for the purpose. For the avoidance of doubt any such temporary chairman may be appointed at the meeting. 10

(3) The quorum for a meeting shall include the chairman and be three, unless at a meeting matters touching or concerning the general manager are under consideration and he is present, when the quorum shall be four. 15

(4) Subject to the foregoing provisions of this paragraph, in the case of equality of votes the chairman shall also have a casting vote.

(5) If for any reason the chairman fails to convene a meeting, the Minister may himself convene the meeting. 20

3.—(1) The corporation may make standing orders for regulating the proceedings of any meeting of the corporation or of any committee of the corporation; but no committee member shall be co-opted from outside the corporation in matters relating to defence.

(2) Where standing orders provide for committees other than of members of the corporation, or comprising partly members thereof and partly persons co-opted for the purpose, they may advise the corporation on matters referred to it by the corporation; but co-opted members shall not be entitled to vote at any meeting they are invited to attend. 25

4.—(1) The application of the seal of the corporation shall be authenticated by the signature of the chairman or by that of the general manager, as the case may be. 30

(2) Every document purporting to be an instrument issued by the corporation and to be so sealed or to be signed on behalf of the corporation, shall be received in evidence and be deemed to be an instrument without further proof unless the contrary is shown. 35

(3) The corporation may sue and be sued in its corporate name and may enter into contracts, and subject to this Act, may engage staff and such technical and other advisers as it deems necessary from time to time. The corporation may also acquire and hold land and any movable property for the purposes of this Act, but no land shall be alienated in any way or be charged as security without the consent in writing of the Minister. 40

(4) Where the Minister satisfies the Council of Ministers that any land to which the Public Lands Acquisition Act applies is required for the purposes of the corporation and that it has been found impracticable to acquire such land by private treaty or agreement, the President may by order direct that proceedings be taken to acquire such land for the federal government; and any land so acquired may thereafter be vested in the corporation under the authority of this subsection by means of a certificate under the hand and seal of the chief federal land officer. 45 50

Supplement to Official Gazette Extraordinary No. 33, Vol. 51, 17th March, 1964—Part C

The following Bill, which will in due course be presented to Parliament for enactment, is published for general information.

## SUPPLEMENTARY APPROPRIATION (1963-64) (No. 2) BILL

### EXPLANATORY MEMORANDUM

This Bill provides for the payment of advances made from the Contingencies Fund.

F. S. OKOTIE-EBOH,  
*Minister of Finance*

## A BILL

### FOR

AN ACT TO AUTHORISE THE ISSUE OUT OF THE CONSOLIDATED REVENUE FUND OF THE SUM OF TWO HUNDRED AND THIRTY THOUSAND, SIX HUNDRED POUNDS FOR THE PURPOSE OF REPLACING ADVANCES FROM THE CONTINGENCIES FUND FOR THE YEAR ENDING ON THE THIRTY-FIRST DAY OF MARCH, ONE THOUSAND, NINE HUNDRED AND SIXTY-FOUR; AND TO APPROPRIATE THAT SUM FOR THE PURPOSES SPECIFIED IN THIS ACT.

[ ]

Commence-  
ment.

BE IT ENACTED by the Legislature of the Federation of Nigeria in this present Parliament assembled and by the authority of the same as follows :—

1. The aggregate amount mentioned in section one of the Appropriation Act, 1963, section one of the Supplementary Appropriation (1963-64) Act, 1963 and in section one of the Supplementary Appropriation (1963-64) Act, 1964 (which together provide for the issue out of the Consolidated Revenue Fund in respect of the year ending on the 31st day of March, 1964, of sums not exceeding in aggregate £58,823,560) shall be increased by two hundred and thirty thousand, six hundred pounds; and the additional amount shall be appropriated for the replacement of advances from the Contingencies Fund.

Issue and appropriation of £230,600 from Consolidated Revenue Fund for Contingencies Fund.  
1963, Nos. 2 and 18;  
1964, No. 7.

2. This act may be cited as the Supplementary Appropriation (1963-64) (No. 2) Act, 1964, and shall apply throughout the Federation.

Short title and extent.



subject to a maximum of £150 per annum. Free Passages for such officers and their wives by sea or air are provided on appointment and on leave between tours to the country from which the officers are recruited. Free medical facilities are provided for all officers and their families.

Other allowances include Children's Separate Domicile Allowance, Outfit Allowance where applicable; Passage Privileges for children and a Car running Allowance.

*Method of application.*—Official application forms are available from the Secretary, Federal Public Service Commission, Private Mail Bag 12586, Lagos, to whom all completed application forms should be returned. Applications of officers in Government Service should be forwarded to the Secretary, Federal Public Service Commission through their Head of Department and be accompanied with a Confidential Report. All applications should reach the Federal Public Service Commission not later than 11th April, 1964.

*Government Notice No. 588*

BOARD OF CUSTOMS AND EXCISE

SALE OF GOODS AT SAPELE

Unless previously cleared, the following unclaimed goods Government Warehoused at SAPELE will be sold by public auction at Government Warehouse, Sapele, on the Wednesday succeeding the elapse of one calendar month from the date of first publication of this notice, commencing at 10 a.m.

<i>Date of report</i>	<i>Name of air-craft or ship</i>	<i>Marks and Nos.</i>	<i>Number of packages</i>	<i>Description of packages</i>
29-10-63	Lagos Palm	DANX SAPELE ..	1	Bale Second Hand Clothing
23-10-63	Kadeik	N/M N/N ..	7	Bags Cement Sweepings
19-11-63	Oti	K. CHELLARAM SAPELE N/N ..	1	Parcel Empty Cartons
24-11-63	Burutu Palm	K.C. BENIN CITY via SAPELE ..	2	Cartons Empty Bottles
31-12-63	Kohima	N/M N/N ..	27	Refilled Cement Bags
12-12-63	Volendam	LAWANDA COUGH C/O BAPTIST HOSPITAL, EKU, SAPELE ..	1	Drum Personal Effects
14-1-64	Andoni Palm	W.R. 1160 B/C via Sapele ..	12	Rolls Carpet
6-2-64	Dalla	ITEM ICAD SAPELE ..	1	Case Sundry
Unknown	Dalla	BDB 4070 BENIN CITY via SAPELE ..	4	Cases Sundry

And a miscellaneous quantity of unidentifiable cargo, lying on the dump or stacking area, or in the Government Warehouse, or any other place, as the case may be.

*Government Notice No. 589*

WESTERN REGION MARKETING BOARD

1963-64 COCOA MARKETING SCHEME TRANSPORT DIFFERENTIAL

It is notified for general information that the Schedule to Government Notice No. 1830 published in the *Official Gazette* No. 73 Vol. 50 of 19th September, 1963 is hereby further amended by the addition of the following particulars on to the appropriate columns as below:—

<i>Station, Benin Province</i>	<i>Transport Differential</i>	<i>Evacuation Route</i>
	£ s d	
Agbanikaka .. .. .	2 3 0	Road to Sapele via Benin City
Okpe .. .. .	4 7 9	Road to Sapele via Benin City
Ososo .. .. .	4 14 0	Road to Sapele via Benin City
Imeri .. .. .	4 11 3	Road to Sapele via Benin City
Ukpilla .. .. .	4 3 0	Road to Sapele via Benin City
Semolika .. .. .	4 5 0	Road to Sapele via Benin City
Warrake .. .. .	3 10 0	Road to Sapele via Benin City

Printed and Published by The Federal Ministry of Information, Printing Division,  
Lagos, Nigeria. 833/364/7,650

Annual Subscription from 1st January each year is : Overseas and Local £4-15s-0d post free. Overseas Second Class Air Mail £6-10s-0d. Present issue (including Supplement) 2s-6d per copy. Subscribers who wish to obtain Gazette after 1st January should apply to the Permanent Secretary, Federal Ministry of Information, Printing Division, Lagos for amended Subscription.



L.N. 38 of 1964

STAMP DUTIES ACT  
(CAP. 191)

**Stamp Duties (Mortgage and Marketable Security Duties)  
Regulations, 1964**

*Commencement : 1st November, 1963*

In exercise of the powers conferred by section 105 of the Stamp Duties Act and of all other powers enabling him in that behalf, the President has made the following regulations—

1. (1) These regulations may be cited as the Stamp Duties (Mortgage and Marketable Security Duties) Regulations 1964, and shall apply to the Federal Territory.

Citation,  
application,  
and com-  
mencement.

(2) These regulations shall be deemed to have come into force on 1st November, 1963.

2. In these Regulations

Interpreta-  
tion.

“the Act” means the Stamp Duties Act ;

“capital duty” means duty on loan capital imposed under the Act ;

“the duty” means the duty in respect of mortgage or marketable security imposed under the Act.

3. Where a trust deed or other document on which the duty is payable, is made or issued subsequent to the issuing of a loan capital which the said trust deed or other document secures, then provided that capital duty has already been paid on the issue of that loan capital, the amount of the duty payable on that trust deed or other document shall—

Compound-  
ing of duty  
in respect  
of certain  
Mortgage or  
Marketable  
security.

(a) be compounded in full in a case where the amount of duty so payable is less than the amount of the capital duty so already paid ; or

(b) be compounded to the extent of the amount of the capital duty so already paid in a case where the amount of the duty so payable exceeds the amount of capital duty.

MADE at Lagos this 14th day of March, 1964.

R. C. ONYEJEPU,  
*Acting Deputy Secretary to  
the Council of Ministers*

EXPLANATORY NOTE

These Regulations make provision for compounding the duty in respect of a mortgage or marketable security where a trust deed or other document, on which such duty is payable, is made subsequent to the issuing of the loan capital which the trust deed or other document secures provided that capital duty on the loan capital had already been paid.

L.N. 39 of 1964

FINANCE (CONTROL AND MANAGEMENT) ACT, 1958  
(No. 33 OF 1958)

Public Funds of the Federation (Disbursement) (Amendment)  
Rules, 1964

Commencement : 31st May, 1962

In exercise of the powers conferred by subsection (1) of Section 23 of the Finance (Control and Management) Act, 1958 and of all other powers enabling him in that behalf, the President has made the following rules—

Short title,  
application  
and  
commence-  
ment.

1.—(1) These rules may be cited as the Public Funds of the Federation (Disbursement) (Amendment) Rules, 1964.

(2) These rules shall apply throughout the Federation and be deemed to have come into operation on the 31st day of May, 1962.

Amendment  
of Fifth  
Schedule to  
L.N. 49 of  
1959.

L.N. 178 of  
1960.

2. The Fifth Schedule to the Public Funds of the Federation (Disbursement) Rules, 1959, as amended by the Public Funds of the Federation (Disbursement) (Amendment) Rules, 1960 is hereby amended by—

(i) the deletion from paragraph 3 of the following—

“and not for commercial profit”; and

(ii) the deletion of paragraph 5.

MADE at Lagos this 11th day of March, 1964.

R. C. ONYEJEPU,  
*Acting Deputy Secretary to the  
Council of Ministers*

L.N. 40 of 1964

IMMIGRATION ACT 1963  
(1963, No. 6)

Philip George Watkins—Prohibited Immigrants Order 1964

WHEREAS as provided under subsection (3) of Section 18 of the Immigration Act, 1963 I am of the opinion that PHILIP GEORGE WATKINS should be classed as a prohibited immigrant :

NOW THEREFORE in exercise of the powers conferred on me by the said subsection (3) of Section 18 of the Immigration Act, 1963 and of all other powers enabling me in that behalf, I hereby order that the said PHILIP GEORGE WATKINS be classed as a prohibited immigrant and deported from Nigeria and shall leave on the next available opportunity and remain thereafter out of Nigeria.

MADE in Lagos this 23rd day of March, 1964.

ALHAJI SHEHU SHAGARI,  
*Federal Minister of Internal Affairs*

The following Bills, which will in due course be presented to Parliament for enactment, are published for general information.

### NATIONAL PROVIDENT FUND

#### EXPLANATORY MEMORANDUM

In operating the National Provident Fund Act 1961 it has been found that the provision establishing the investment committee does not include regional representation and clause four of this Bill makes all necessary changes to provide for such representation.

Other provisions are mainly amendments to give the director better control for administrative purposes over the fund itself.

J. M. JOHNSON,  
*Minister of Labour*

#### ARRANGEMENT OF CLAUSES

*Clause*

- |   |  |
|---|--|
| <p>1. Additional representation on Advisory Council from new Regions.</p> <p>2. Liability of employer to pay certain moneys into the Fund.</p> <p>3. Member may receive further benefit in certain cases.</p> | <p>4. National Provident Fund Committee and sub-committee.</p> <p>5. Failure to produce certain records an offence.</p> <p>6. Miscellaneous amendments.</p> <p>7. Short title, citation and application.</p> |
|---|--|

## A BILL

### FOR

AN ACT TO AMEND THE NATIONAL PROVIDENT FUND ACT, 1961.

[ ]

Commencement.

BE IT ENACTED by the Legislature of the Federation of Nigeria in this present Parliament assembled and by the authority of the same as follows :—

- 5 1.—(1) If before or after the passing of this Act further Regions are created and the like representation on the Advisory Council as constituted under section eight of the National Provident Fund Act 1961 (in this Act referred to as "the principal Act") as is accorded to other Regions is desired by any such Region, the Minister may by order in the Gazette amend the Constitution of that Council to the extent necessary to give
- 10 effect to such desire and the First Schedule to the principal Act shall have effect accordingly, so however that the total membership of the Advisory Council shall not at any one time exceed twenty-five ; and if the membership is increased under this subsection the Minister may, by the same or any other order, fix a quorum for any meeting.
- 15 (2) Where the said First Schedule is amended under the foregoing subsection and persons are appointed to membership, they shall have all the powers of members of the Advisory Council and the provisions of the principal Act as to payment of expenses and allowances of members shall be so construed and have effect.

Additional representation on Advisory Council from new Regions.

Liability of employer to pay certain moneys into the Fund.  
1961 No. 20.

Member may receive further benefit in certain cases.

National Provident Fund Committee and sub-committee.

2. It is declared for the avoidance of doubt that where by the principal Act an employer is required to deduct a worker's contribution and pay it into the Fund within a prescribed time, the employer shall pay into the Fund at the same time his own contribution as an employer of the worker concerned; and section thirteen of the principal Act (which requires an employer to deduct a worker's contribution for payment into the Fund) shall be construed accordingly. 5

3. If a member receives a benefit under the principal Act and at any time thereafter qualifies for a further benefit he shall, to the extent to which he still has moneys in the Fund and notwithstanding anything to the contrary in section twenty-eight of the principal Act (which imposes restrictions on double grant or benefit), be entitled to such further benefit although he may not have again become a contributor. 10

4.—(1) There shall be a committee to be known as the National Provident Fund Investment Committee (hereafter called "the investment committee") for the control of investment of moneys in the Fund not required for the acquisition of property of any description under the principal Act; and the investment committee shall consist of one member from each Region to be appointed by the Minister on the nomination of the Minister in that Region charged with responsibility for finance, and the following representatives or holders of office appointed by the Minister as Federal territory members that is to say,— 15

- (a) one fit officer of the Federal Ministry of Finance,
- (b) one fit officer of the Central Bank of Nigeria nominated by the Governor of that Bank, and
- (c) the Director. 25

(2) Regional members appointed under the foregoing subsection shall hold office for a period of two years, or if appointed by office then during the tenure of such office, but with that reservation they shall be eligible for reappointment; and Federal territory members so appointed shall hold office during the continuance of their employment in the Federal territory, but may be removed from office by the Minister without the necessity for assigning any reason. 30

(3) The persons who, immediately before the commencement of this Act were members of the investment committee, shall be deemed to have been reappointed by the Minister under this subsection as Federal territory members of the investment committee; and members so re-appointed or, as the case may be, appointed as Federal territory members by the Minister shall, while they continue to be employed in the Federal territory, comprise the sub-committee referred to in the next following subsection. 35 40

(4) The every day business of investment under this Act shall be transacted by the Federal territory members who shall comprise a sub-committee of the investment committee for the purpose and be responsible only to the Minister. The Minister shall appoint a date for the first report to the investment committee, and thereafter the sub-committee shall at intervals of not more than three months report to the investment committee on investments made by the sub-committee under its powers conferred by this subsection. 45

(5) Moneys for investment shall be invested only in securities in Nigeria authorised by the Trustee Investment Acts 1957 and 1962, and unless the Minister, after consultation with the Federal Minister charged with responsibility for finance otherwise directs, investments shall be restricted to securities created or issued by or on behalf of the Government of the Federation. In the application of this subsection, the question whether the Minister has in any case so acted and whether he has received such advice shall not be enquired into by any court.

of 1962,  
No. 13.

(6) Subject to the provisions of this section the investment sub-committee may, and if required by the investment committee shall, from time to time give directions either generally or specially as to the investment of any moneys held for such purpose; and for the guidance of the investment committee or of the sub-committee as the case may require, the Director shall give such information as to moneys in the Fund and other matters as the investment committee or the sub-committee may reasonably require.

(7) The investment committee and the sub-committee of the investment committee may each regulate its own procedure at meetings and appoint their respective chairmen. Meetings of the investment committee shall be held as often as the Minister by notice in writing to the chairman may direct or require; but meetings of the investment sub-committee shall be held at such times and places as the chairman may appoint. If either chairman is absent, or refuses or is unwilling to act, the Minister may appoint a time and place for a meeting, and may nominate the chairman for the meeting.

(8) In the absence of the Director he may nominate some other officer of the Fund to attend meetings; and any officer so nominated shall, for any meetings attended be deemed to be a member of the investment committee or of the sub-committee, as the case may be.

(9) A Regional member may be removed from office for incompetence or inability to act if his nominator so directs the Minister, or a Regional member may resign his office by notice in writing to the Minister under this Act; and while they continue in office, regional members attending meetings of the investment committee shall be paid out the Fund such expenses and allowances as the Federal Minister charged with responsibility for finance may from time to time approve.

5. Section thirty-five of the principal Act (which prescribes sundry offences) is amended by adding immediately after subsection (1) a new subsection (1A) as follows—

“(1A) Any employer or other person required to produce to the Fund records of the contributions of a member, who fails without reasonable excuse (the proof whereof shall lie upon him) to produce a quarterly record within three months after the end of the quarter, commits an offence under this Act.”

Failure to  
produce  
certain  
records an  
offence.

6. The principal Act is further amended to the extent set out in the Schedule to this Act.

Miscellaneous  
amendments.

7.—(1) This Act may be cited as the National Provident Fund Act, 1964 and this Act and the principal Act may be cited together as the National Provident Fund Acts, 1961 and 1964.

Short title  
citation and  
application.

(2) This Act shall apply throughout the Federation.

SCHEDULE

Section 6

<i>Number</i>	<i>Short title</i>	<i>Extent of amendment</i>
1961 No. 20	The National Provident Fund Act, 1961	In section sixteen by repealing the words "jointly and"; Section twenty-nine is repealed; In section thirty by repealing all words from the commencement as far as the word "section", and by substituting for the marginal note the words "Power to purchase land, etc."

(Bills 884)

## NAVY BILL

## EXPLANATORY MEMORANDUM

By reason of the change in the international status of Nigeria it has become necessary to replace the existing legislation relating to the navy. This Bill seeks to give effect to the republican status of Nigeria accordingly, with sundry other alterations which are incidental thereto.

M. T. MBU,  
*Minister of State for Navy*

## ARRANGEMENT OF CLAUSES

*Clause*

## PART I—ESTABLISHMENT OF NAVY

1. Establishment, etc. of navy.,
2. Establishment of naval reserve.

PART II—ESTABLISHMENT OF  
NAVY BOARD

3. Establishment of navy board.
4. Membership of board.
5. Powers of board.

PART III—ADMINISTRATION AND  
GOVERNMENT*Command*

6. Command of the navy.
7. Powers of command of members of co-operating army or air force units.
8. Attachment of members of the navy to the army or air force.
9. Attachment of personnel and powers of command.
10. Regulations as to command.

*Officers*

11. Appointment of officers.
12. Promotion of officers, etc.
13. Recall of officers who have retired, etc.
14. Regulations as to officers.

*Enlistment and Terms and  
Conditions of Service*

15. Recruiting officers.
16. Enlistment.
17. Terms of enlistment.
18. Re-engagement and continuance in service.
19. Prolongation of service.

*Discharge and Transfer to the  
Reserve*

20. Discharge.
21. Transfer to the reserve.
22. Postponement of discharge or transfer pending proceedings for offences, etc.
23. Right of chief petty officer to discharge on reduction to ordinary rating.
24. Power to discharge.
25. Right of rating to purchase discharge.

*Miscellaneous and Supplementary*

26. Rules for reckoning service.
27. Validity of attestation and enlistment.
28. Pension provisions.
29. Provisions as to death and injury.
30. Liability for service outside Nigeria.
31. Interpretation of, and power to make certain regulations for, this Part.

PART IV—DISCIPLINE AND TRIAL  
AND PUNISHMENT OF NAVAL  
OFFENCES

32. Application.

*Misconduct in Action and  
Assistance to the Enemy*

33. Misconduct in action by persons in command.
34. Misconduct in action by other officers and ratings.
35. Obstruction of operations.
36. Corresponding with, supplying or serving with the enemy.

ARRANGEMENT OF CLAUSES—*continued*

- Clause*
37. Wilful neglect and failure to rejoin forces, etc.
38. Offences against morale.
39. Sleeping on watch or abandoning post.
40. Neglect of duty.
- Mutiny*
41. Definition of mutiny.
42. Offences of mutiny.
43. Failure to suppress mutiny.
- Insubordination and Similar Offences*
44. Striking superior officer.
45. Disobedience or threatening superior officer.
46. Fighting and quarrelling.
47. Obstruction of provost officers.
48. Disobedience to standing orders.
- Desertion and Absence without leave*
49. Desertion.
50. Absence without leave, etc.
51. Assisting and concealing desertion and absence without leave.
- Navigation and Flying Offences*
52. Loss or hazarding of ship or aircraft.
53. Dangerous flying, etc.
54. Low flying.
55. Annoyance by flying.
- Prize Offences*
56. Prize offences by commanding officers.
57. Other prize offences.
58. Looting.
- Other Offences in respect of Ships and Aircraft*
59. Inaccurate certification of ships, etc.
60. Improper carriage of goods.
- Malingering and Drunkenness*
61. Malingering.
62. Drunkenness.
- Offences relating to Property*
63. Misapplication and destruction of public and service property.
64. Loss and waste of public and service property.
65. Offences in relation to property of members of forces.
- Offences relating to and by Persons in Custody*
66. Irregular arrest and confinement.
67. Permitting escape and unlawful release of prisoners.
68. Resisting arrest.
69. Escape from confinement.
- Offences in relation to Courts Martial and Civil Authorities*
70. Offences in relation to courts martial.
71. False evidence.
72. Obstruction of police officer arresting officer or rating.
- Miscellaneous Offences*
73. Injurious disclosures.
74. Making of false statements on enlistment.
75. Scandalous conduct of officer.
76. Ill-treatment of officers or rating of inferior rank.
77. Disgraceful conduct.
78. False accusation.
79. Conduct to prejudice of naval discipline.
- Attempts and Aiding and Abetting of Naval Offences*
80. Attempts to commit naval offences.
81. Aiding and abetting naval offences.
- Civil Offences*
82. Civil offences.
- Punishments*
83. Punishment of officers.
84. Punishment of ratings.
- Arrest*
85. Power to arrest offenders.
86. Provision for avoiding delay after arrest.
- Investigation of and Summary Dealing with Charges*
87. Investigation of charges by commanding officer.
88. Summary trial of officers.
89. Summary trial of ratings.
90. Charges to be dealt with summarily or by court martial.
- Court Martial : General Provisions*
91. Jurisdiction of courts martial.
92. Officers having power to convene courts martial.
93. Composition of courts martial.
94. Appointment of judge advocate.
95. Place and time for sitting of court martial.
96. Dissolution of court martial.
97. Challenges by accused.
98. Administration of oaths.
99. Court martial to sit in open court.
100. Decision of court martial.
101. Finding and sentence.
102. Power to convict of offence other than that charged.

ARRANGEMENT OF CLAUSES—*continued*

## Clause

103. Rules of evidence.  
 104. Privileges of witnesses and others at court martial.  
 105. Summoning of witnesses.  
 106. Offences by civilians in relation to courts martial.  
*Confirmation, Revision and Review of Proceedings of Courts Martial*  
 107. Confirmation of proceedings of court martial.  
 108. Petitions against finding or sentence.  
 109. Revision of findings of court martial.  
 110. Powers of confirming authority.  
 111. Confirming authorities.  
 112. Death sentence to be approved.  
 113. Review of findings and sentences of court martial.  
 114. Reconsideration of sentences of imprisonment.  
*Review of Summary Findings and Awards*  
 115. Review of summary findings and awards.  
*Findings of Insanity, etc.*  
 116. Provisions where accused found insane.  
*Commencement, Suspension and Duration of Sentences*  
 117. Commencement of sentences.  
 118. Duration of sentences of imprisonment.  
 119. Special provisions as to civil prisons.  
 120. Serving of sentences outside Nigeria.  
 121. Country in which sentence of imprisonment is to be served.  
 122. Duties of persons in charge of prisons and others to receive prisoners.  
*Trial and Time Limit of Persons ceasing to be Subject to Naval Law*  
 123. Trial, etc., of offences although offender no longer subject to naval law.  
 124. Limitation of time for trial of offences under this Act.  
*Relations between Naval and Civil Courts and Finality of Trials*  
 125. Powers of civil courts.  
 126. Offences already disposed of not to be re-tried.  
*Inquiries*  
 127. Boards of inquiry.  
 128. Inquiries into absence.  
*Miscellaneous Provisions*  
 129. Restitution or compensation for theft, etc.
130. Promulgation of findings, etc.  
 131. Custody of proceedings of court martial and right to copies.  
 132. Indemnity for prison officers, etc.  
*Redress of Complaints*  
 133. Complaints by officers and ratings.  
 134. Power to refer complaints by officer to the President.  
*Rules of Procedure, etc.*  
 135. Rules of procedure and other rules. Interpretation of this part.  
 136. Interpretation of Part IV.  
 PART V—APPEALS FROM COURTS MARTIAL  
 137. Right of Appeal.  
 138. Procedure for applying for leave to appeal or lodging appeal.  
 139. Determination of appeals in ordinary cases.  
 140. Powers of the Supreme Court in special cases.  
 141. Appeals to be final.  
 142. Supplementary powers of the Supreme Court.  
 143. Proceedings to be heard in absence of appellants.  
 144. Defence of appeals.  
 145. Right of appellant to present his case in writing.  
 146. Suspension of death sentence.  
 147. Persons not to be tried again where conviction quashed.  
 148. Removal of prisoners for purposes of proceedings.  
 149. Furnishing, on appeal, of documents relating to trial  
 150. Duties of Registrar of the Supreme Court in respect of appeals, etc.  
 151. Rules of Court.  
 152. Saving of reviewing authorities' powers.  
 153. Composition of court.  
 154. Exercise of certain powers of the Supreme Court by a Justice.  
 155. General provisions as to procedure.  
 PART VI—PAY, FORFEITURES AND DEDUCTIONS  
 156. Regulations as to pay.  
 157. Forfeitures and deductions: general provisions.  
 158. Forfeiture of pay for absence from duty.  
 159. Deductions for payment of civil penalties.  
 160. Compensation for loss occasioned by wrongful act or negligence.  
 161. Deductions for barrack damage.  
 162. Remission of forfeitures and deductions.

## Clause

ARRANGEMENT OF CLAUSES—*continued*

## PART VII—GENERAL PROVISIONS

*Exemptions for Members of Navy*

- 163. Exemption from tolls, etc.
- 164. Exemption from taking in execution of property used for Naval purposes.
- 165. Exemptions as to arms and explosives.

*Deserters and Absentees without Leave*

- 166. Arrest of deserters and absentees without leave.
- 167. Proceedings before a civil court where persons suspected of illegal absence.
- 168. Deserters and absentees without leave surrendering to police.
- 169. Certificates of arrest or surrender.
- 170. Duties of superintendents of prisons and others to receive deserters and absentees.

*Offences relating to Naval Matters punishable by Civil Courts*

- 171. Punishment for pretending to be a deserter.
- 172. Punishment for procuring and assisting desertion.
- 173. Punishment for obstructing members of the navy.
- 174. Punishment for aiding malingering.
- 175. Unlawful purchase, etc., of naval stores.
- 176. Illegal dealings in documents relating to pay, pensions, mobilisation, etc.
- 177. Unauthorised use of, and dealing in, decorations, etc.
- 178. Intoxicating liquor not to be conveyed on board any naval ship.

*Evidence*

- 179. Special provisions as to evidence.
- 180. Proof of outcome of civil trial.
- 181. Evidence of proceedings of court martial.

*Reductions in Rank*

- 182. Restrictions on disrating.

*Miscellaneous Provisions*

- 183. Temporary reception into civil custody of persons under escort.
- 184. Avoidance of assignment of, or charge on, naval pay, etc.
- 185. Power of certain officers to take statutory declarations.

## PART VIII—RESERVISTS AND PENSIONERS

- 186. Reservists and pensioners.
- 187. Annual training.
- 188. Calling out of reservists and pensioners to aid the civil power.

- 189. Calling out of reservists and pensioners on permanent service.

- 190. Punishment for non-attendance.
- 191. Record of illegal absence.
- 192. Discharge during service.
- 193. Regulations as to the reservists and pensioners.

## PART IX—APPLICATION OF THE ACT AND SUPPLEMENTARY PROVISIONS

*Application*

- 194. Application of the Act.
- 195. Application of the Act to women.
- 196. Application of the Act to civilians.
- 197. Application of the Act to passengers.

*Wills and Distribution of Property*

- 198. Ratings on enlistment to register the name of persons to whom estate is to be paid in event of his dying intestate.
- 199. Ratings' wills: special provisions.
- 200. Distribution in case of deceased ratings intestacy.
- 201. Payment of debts of deceased rating.
- 202. Property of deceased rating distributed subject to rights of creditors.
- 203. Deceased rating's money undisposed of applied to prescribed fund.
- 204. Application of money, etc., in case of desertion.
- 205. Uniforms and decorations of deceased rating.

*Miscellaneous*

- 206. Power to make regulations generally.
- 207. Powers exercisable in subsidiary legislation.
- 208. Provisions as to active service.
- 209. Execution of orders, instruments, etc.
- 210. Nigerian Navy Benefit Fund.
- 211. Rights of officers.
- 212. Application of other Acts.
- 213. Repeal and transitional provisions.
- 214. Savings.
- 215. Interpretation.

## SCHEDULES

- First Schedule—Officers who can try ratings summarily and powers, etc.
- Second Schedule—Alternative offences on conviction by court martial.
- Third Schedule—Transitional provisions.
- Fourth Schedule—Enactments repealed.

# A BILL

FOR

AN ACT TO MAKE OTHER PROVISION FOR THE ESTABLISHMENT, GOVERNMENT AND DISCIPLINE OF THE NIGERIAN NAVY AND OF THE NAVAL RESERVE AND TO PROVIDE FOR OTHER MATTERS CONNECTED THEREWITH OR ANCILLARY THERETO.

[Section 216 (1)]

Commence-  
ment.

BE IT ENACTED by the Legislature of the Federation of Nigeria in this present Parliament assembled and by the authority of the same as follows :—

## PART I.—ESTABLISHMENT OF NAVY

5           1.—(1) There shall be established and maintained in and for the Federal Republic a naval force to be known as the Nigerian Navy (hereafter in this Act referred to as “the navy”) which shall consist of such establishments as the President may, acting in accordance with the advice of the Council of Ministers, think fit, and such numbers of ships and other vessels, officers, non-commissioned officers and men as the navy board as constituted under this Act may, from time to time, prescribe.

Establish-  
ment, etc.,  
of navy.

(2) The navy shall be charged with—

- 15           (a) the naval defence of Nigeria ;  
             (b) the duty of assisting in the enforcement of the customs laws of Nigeria ;  
             (c) the making of hydrographic surveys ;  
             (d) training in naval duties ; and  
20           (e) such other duties as the Council of Ministers may from time to time direct.

(3) It is hereby declared that the authority created by this Act to establish and maintain a naval force shall include authority to raise and maintain units of or including women and accordingly the provisions of this Act shall apply to women subject to section one hundred and ninety-five and to such modifications and adaptations as the President may by order specify from time to time.

(4) The navy shall not form part of the public service of the Federation.

25           2. There shall be established and maintained a naval reserve consisting of such numbers of officers and ratings who are transferred to it on completion of their period of service in the navy and of such others as may be prescribed.

Establish-  
ment of  
naval reserve.

## PART II.—ESTABLISHMENT OF NAVY BOARD

35           3.—(1) Subject to the provisions of subsection (2) of this section, there shall be established a board to be known as the Navy Board (in this Act referred to as “the board”) which shall be responsible under the general authority of the Minister for matters relating to the command, discipline and administration of, and all other matters relating to, the navy.

Establish-  
ment of  
navy board.

(2) Notwithstanding the provisions of the preceding subsection, the board shall have no responsibility for the operational use of the navy and responsibility for any such use shall be vested in the commander subject to the overall directions of the Council of Ministers :

Provided that the Prime Minister may give to the commander such directions with respect to the operational use of the navy in Nigeria for the purpose of maintaining and securing public safety and public order, notwithstanding that the directions of the Council of Ministers have not been obtained, and the commander shall comply with those directions accordingly.

Membership  
of board.

4.—(1) Membership of the board shall consist of—

- (a) the Minister, who shall be the chairman of the board ;
- (b) the Minister of State responsible for the navy ;
- (c) the commander ;

(d) the permanent secretary of the Ministry responsible for defence, who shall also be the secretary of the board ; and

(e) such other persons as the Prime Minister may appoint.

(2) The chairman may from time to time nominate any member of the board to perform the duties of the chairman at any meeting of the board at which the chairman is absent and such nomination may be either general or in respect of a particular occasion.

Powers of  
board.

5. The board may provide for all or any of the following matters—

(a) the organisation of the work of the board and the manner in which it shall perform its functions and the duties and responsibilities of the members thereof ;

(b) the delegation by notification in the Gazette to any member of the board of any of the powers or duties of the board ;

(c) the consultation by the board with persons other than members thereof ; and

(d) the procedure to be followed by the board in conducting its business.

### PART III—ADMINISTRATION AND GOVERNMENT

#### Command

Command of  
the navy.

6.—(1) The President on the advice of the Prime Minister may appoint such officer (in this Act referred to as "the commander") as he thinks fit, in whom the command of the navy and the naval reserve shall be vested and, subject to the terms of his appointment and to such directions in relation to the operational use of the navy as may be given under subsection (2) of section three of this Act, the commander shall have the command, direction and general superintendence of the navy and the naval reserve.

(2) The Prime Minister before tendering advice shall consult with the board, but the question as to whether any consultation was held or what happened in the course of a consultation, shall not be enquired into by any court.

7. In so far as powers of command depend on rank, a member of any army or air force unit who is acting together with any naval unit (either with or without his unit or any part of it) shall have the like powers as a member of the navy of corresponding rank; and for the purposes of sections forty-four, forty-five and eighty-five of this Act any such member of an army or air force unit shall be treated as if he were a member of the navy of corresponding rank.

Powers of command of members of co-operating army or air force units.

8.—(1) Any member of the navy may be attached temporarily to the army or the air force by order of the competent naval authority.

Attachment of members of the navy to the army or air force.

(2) Regulations made by the appropriate service authorities may prescribe circumstances in which officers, chief petty officers, petty officers and men of the navy shall be deemed to be attached to the army or the air force, as the case may be, under the last foregoing subsection.

(3) In this section the expression "appropriate service authorities" means—

(a) in relation to attachment to the army, the Nigerian Army Council and the board; and

(b) in relation to attachment to the air force, the Nigerian Air Council and the board.

(4) A person shall not cease to be subject to naval law under this Act by reason only of attachment in pursuance of this section.

9.—(1) The Minister may by order direct that this section shall apply to any military, naval, or air force of a country (other than Nigeria) and where the Minister so directs the application of this section, the board—

Attachment of personnel and powers of command.

(a) may attach temporarily to the navy any member of the foreign country to which the other force belongs; or

(b) subject to anything to the contrary in the conditions applicable to his service, may place any member of the navy at the disposal of the service authorities of a foreign country for the purpose of being attached temporarily by those authorities to the foreign force or force of that country.

(2) Where a member of a foreign force is by virtue of this section attached temporarily to the navy as an officer or rating as the case may be he shall, for the period of attachment, be subject to this Act to the extent to which its application to him is not modified by any order which the Minister may make under this subsection, in like manner as if he were a member of the navy of relative rank; and accordingly he shall be so treated and have like powers of command and punishment over members of the navy.

(3) When the navy and a foreign force to which this section applies are serving together whether alone or not—

(a) any member of the foreign force shall be treated and shall have over members of the navy the like powers of command as if he were a member of the navy of relative rank; and

(b) if the forces are acting in combination, any officer of the foreign force appointed by the board, or in accordance with regulations made by the board, to command the combined force, or any part thereof, shall have over members of the navy the like powers of command

and punishment and may be invested with the like authority to convene, and confirm the findings and sentences of, courts martial as if he were an officer of the navy of relative rank and holding the same command.

(4) For the purposes of this section, forces shall be deemed to be serving together or acting in combination if and only if they are by order of the board declared to be so serving or so acting ; and the relative rank of members of the navy and of the foreign force shall be such as may be prescribed by regulations made by the board.

Regulations  
as to  
command.

10. The President may make regulations as to the persons in whom command over the establishments and units or any member thereof is vested and as to circumstances in which such command as aforesaid is to be exercised and, without prejudice to the generality of the foregoing, may in such regulations provide for the duties, functions and powers of the command, its naval staff and officers, chief petty officers, petty officers and ratings.

### Officers

Appointment  
of officers.

11.—(1) No person shall be appointed to a commission in the navy unless he has been recommended by a board of officers set up by the board.

(2) A person recommended for appointment to a commission in the navy shall be appointed to a commission either for an indefinite period or for a specified time.

(3) Every officer on appointment shall be issued with a commission in the form prescribed by regulations made under section fourteen of this Act and signed by the President.

(4) The appointment of a person to a commission in the navy shall be notified in the Gazette.

Promotion  
of officers,  
etc.

12. All promotions of officers and any retirement or resignation of an officer shall be notified in the Gazette.

Recall of  
officers who  
have retired,  
etc.

13. An officer who has retired or was permitted to resign may be recalled in an emergency in accordance with regulations made under this Act, and on such recall, shall be liable to serve until he is released or discharged.

Regulations  
as to  
officers.

14. The President may make regulations governing the commissioning of officers, their terms of service, promotion, retirement, resignation and such other matters concerning officers of the navy as seem to him necessary.

### Enlistment and Terms and Conditions of Service

Recruiting  
officers.

15. Any person authorised in that behalf by regulations made under this Part of this Act may enlist recruits in the navy.

16.—(1) A person offering to enlist in the navy shall be given a notice in the prescribed form setting out questions to be answered on attestation and stating the general conditions and engagement to be entered into by him, and a recruiting officer shall not enlist any person in the navy unless satisfied by that person that he has given such a notice, understands it and wishes to be enlisted.

Enlistment.

(2) A recruiting officer shall not enlist a person under the apparent age of eighteen years unless consent to the enlistment has been given in writing by his parents or guardian or, where the parents or guardian are dead or unknown, by some persons approved by an administrative officer of the division of the Region or of the Federal territory, as the case may be, in which such person applying for enlistment resides.

17.—(1) The term for which a person enlisting in the navy may be enlisted shall be such a term, beginning with the date of his attestation, as is mentioned in the following provisions of this section.

Terms of enlistment.

(2) Where the person enlisting has apparently attained the age of eighteen years the term of enlistment shall, as may be prescribed, not exceed twelve years and be classed—

(a) as a term of regular service ; or

(b) as to a prescribed part, a term of regular service, and as to the remainder a term of service in the naval reserve.

(3) Where the person enlisting has not apparently attained the age of eighteen years the term shall be a term ending with the expiration of such period not exceeding twelve years as may be prescribed beginning with the date on which he attained such age, and be classed—

(a) as a term of regular service ; or

(b) as to a prescribed part, a term of regular service and as to the remainder, a term of service in the naval reserve.

18.—(1) Any rating before or after completing the term of his regular service may with the approval of the competent naval authority re-engage for such further period or periods of regular service and service in the reserve as may be prescribed :

Re-engagement and continuance in service.

Provided that—

(a) at the expiration of twelve years of continuous regular service from the date of his original attestation or the date when he apparently attained the age of eighteen years, whichever is the later, all reserve service due by him shall be deemed to have been completed ; and

(b) such further period or periods of regular service, together with the original period of regular service, shall not, except as provided by subsections (2) and (3) of this section, exceed a total continuous period of eighteen years of regular service from the date of the rating's original attestation or the date upon which he apparently attained the age of eighteen years, whichever is the later.

(2) Any rating who has completed a period of eighteen years of regular service may, if he so desires and with the approval of the competent naval authority, continue to serve to complete twenty-two years of regular service in all respects as if his term of regular service was still unexpired.

Provided that—

(a) it shall be lawful for him to claim his discharge at the expiration of three months after he has given notice to his commanding officer of his wish to be discharged; and

(b) it shall be lawful for his commanding officer to give him three months notice of intention to discharge him. 5

(3) Any rating who has completed a period of twenty-two years of regular service may, if he so desires and with the approval of the competent naval authority, continue to serve in all respects as if his term of regular service was still unexpired. 10

Prolongation of service.

19. Any rating whose term of regular service expires during a state of war, insurrection, hostilities or public emergency may be retained in the navy and his service prolonged for such further period as the competent naval authority, with the approval of the Minister, may direct. 15

#### *Discharge and Transfer to the Reserve*

Discharge.

20.—(1) Unless otherwise prescribed by this Act, if a rating becomes entitled to be discharged, he shall be discharged with all convenient speed; but until discharged he shall remain subject to naval law under this Act. 20

(2) If a rating entitled to be discharged is serving out of Nigeria and his term of service is prolonged under this Act, he shall be returned to Nigeria free of cost with all convenient speed, and be discharged on his arrival in Nigeria or, if he consents to his discharge being delayed, within six months from his arrival. 25

(3) Except in pursuance of the sentence of a court martial under service law, a rating shall not be discharged unless his discharge has been authorised by order of the competent naval authority in accordance with regulations made under this Part of this Act.

(4) Every rating shall be given on his discharge a certificate of discharge containing such particulars as may be prescribed: 30

Provided that a rating who is discharged within six months of the date of attestation shall not be entitled to receive a certificate of discharge.

(5) A rating who is discharged in Nigeria shall be entitled to be conveyed free of cost from the place where he is discharged to the place stated in his attestation paper to be the place where he was attested or to any place at which he intends to reside and to which he can be conveyed with no greater cost. 35

Transfer to the reserve.

21.—(1) Subject to the provisions of this Act, every rating whose term of service requires his transfer to the naval reserve shall, when so due, be transferred to that reserve; but until he is so transferred, he shall remain subject to this Act. 40

(2) When a rating due for transfer to the naval reserve is serving outside Nigeria he shall be returned to Nigeria free of cost with all convenient speed and be transferred to such reserve on his arrival in Nigeria; or if he consents to his transfer being delayed he shall be so transferred not later than six months from the date of his arrival in Nigeria. 45

(3) A rating who is transferred to the reserve in Nigeria shall be entitled to be conveyed free of cost from the place where he is transferred to the place stated in his attestation paper to be the place where he was attested or to any place at which he intends to reside and to which he can be conveyed with no greater cost.

(4) Any rating due for transfer to the naval reserve may, instead of being so transferred, be discharged forthwith by a competent naval authority without assigning any reason; and if a rating is so discharged the provisions of section twenty of this Act shall have effect instead of the foregoing provisions of this section.

22. Notwithstanding anything in this Part of this Act—

(a) a rating shall not be entitled to be discharged or transferred to the naval reserve at a time when he has become liable, as a person subject to service law, to be proceeded against for an offence against any of the provisions of service law by way of trial by court martial;

(b) a rating who is serving a sentence of imprisonment or detention awarded by a court martial under service law or by his commanding officer shall not be entitled to be discharged or transferred to the naval reserve during the currency of the sentence.

23. Unless there exists a state of war or public emergency or there is an insurrection or hostilities have commenced, if a chief petty officer is reduced to ordinary rating he may thereupon claim to be discharged.

24. A rating may be discharged by a competent naval authority at any time during his term of engagement.

25.—(1) Subject to the provisions of section nineteen of this Act, a rating may claim his discharge within six months after the date of his first attestation, and if a competent naval authority approves, he shall, on payment of a sum of not more than ten pounds as may be determined by such authority, be discharged accordingly.

(2) Nothing in section twenty of this Act shall apply to any such discharge, and until his discharge the rating shall remain subject to naval law under this Act.

#### *Miscellaneous and Supplementary*

26.—(1) In reckoning the service of any rating for discharge or re-engagement or transfer to the naval reserve there shall be excluded therefrom—

(a) all periods during which he has been absent from duty for any of the following causes—

(i) imprisonment;

(ii) desertion;

(iii) absence without leave exceeding twenty-eight days; and

(b) any period ordered by a court martial to be forfeited.

(2) Regulations under this Part of this Act may make provision for restoring service excluded by the provisions of subsection (1) of this section in consideration of good service or on other grounds justifying the restoration of service so excluded.

Postpone-  
ment of dis-  
charge or  
transfer  
pending  
proceedings  
for offences,  
etc.

Right of  
chief petty  
officer to  
discharge on  
reduction to  
ordinary  
rating.

Power to  
discharge.

Right of  
rating to  
purchase  
discharge.

Rules for  
reckoning  
service.

Validity of  
attestation  
and enlist-  
ment.

27.—(1) Where a person has upon attestation made the prescribed declaration and thereafter receives pay as a rating—

(a) the validity of his enlistment shall not be called in question on the grounds of any error or omission in his attestation paper ; 5

(b) after the expiration of a period of three months from the date on which he made the said declaration he shall be deemed to have been validly enlisted notwithstanding any non-compliance with the requirements of this Act or any other ground whatsoever (not being an error or omission in his attestation paper) ;

and accordingly he shall be a rating until his discharge under this Act. 10

(2) Where a person has received pay as a rating without having previously made the prescribed declaration for enlisting he may claim his discharge at any time ; and if he makes such claim, the claim shall be submitted as soon as may be to the competent naval authority who shall cause him to be discharged with all convenient speed. Until he is discharged, he shall be deemed to be a rating. 15

(3) Nothing in the foregoing provisions of this section shall be construed as prejudicing the determination of any question as to the term for which a person was enlisted or as preventing the discharge of a person who has not claimed his discharge. 20

Pensions  
provisions.  
Cap. 119.

28. For the purpose of the Military Pensions Act, service with the navy shall be deemed to be service in the Nigerian Army, and accordingly the provisions of that Act shall apply in respect of members of the navy as they apply to members of the Army, but subject to such modifications as may be prescribed by the Council of Ministers. 25

Provisions  
as to death  
or injury.  
Cap. 119.

29.—(1) Every officer or rating of the navy to whom the Military Pensions Act applies who in the actual discharge of his duty and without his own default has received wounds or injuries or suffered illness shall, subject to the provisions of section twenty-eight of this Act, be entitled to the like benefits under the Military Pensions Act as are accorded to members of corresponding rank in the Army. 30

(2) The family of any officer or rating of the navy who has been killed or has died of wounds received on active service, or who has died through illness directly attributable to fatigue or exposure incidental to such service, shall be entitled to such benefits under the Military Pensions Act as may be prescribed. 35

(3) For the purpose of this section “family” and “active service” shall have the respective meanings as may from time to time be assigned to these expressions by regulations made under section thirty-one of this Act. 40

Liability for  
service out-  
side Nigeria.

30. The President may by order direct that any officer or rating of the navy shall proceed to any place outside Nigeria for the purpose of undergoing instruction or training or for duty or employment.

Interpreta-  
tion of, and  
power to  
make certain  
regulations  
for, this Part.

31.—(1) In this Part of this Act, “competent naval authority” means any officer designated as such by the board for the purposes of this Part of this Act. 45

(2) The board with the approval of the Minister may make such regulations as appear to the board to be necessary or expedient for the purpose of, or in connection with, the enlistment of recruits for the navy

and generally for carrying this Part of this Act into effect. Without prejudice to the generality of the foregoing such regulations may make provision—

- 5 (a) for prescribing the form of attestation paper to be used ; and  
(b) for an oath or affirmation to be administered on enlistment.

PART IV.—DISCIPLINE AND TRIAL AND PUNISHMENT  
OF NAVAL OFFENCES

- 10 32. The provisions of this Part of this Act as to discipline and offences shall apply only to persons who, for the time being, are subject to this Act, unless the context otherwise requires. Application.

*Misconduct in Action and Assistance to the Enemy*

- 15 33. Any officer or other person who, being in command of any ship, vessel, aircraft or shore establishment of the navy— Misconduct in action by persons in command.
- (a) fails to use his utmost exertion to bring into action any such ship, vessel or aircraft which it is his duty to bring into action ;
- (b) surrenders any such ship, vessel or aircraft to the enemy when it is capable of being successfully defended or destroyed ;
- 20 (c) fails to pursue any enemy whom it is his duty to pursue, or to assist to the utmost of his ability any friend whom it is his duty to assist ;
- (d) in the course of any action by or against the enemy, improperly withdraws from the action or from his station, or fails in his own person and according to his rank to encourage the persons under his command to fight courageously ; or
- 25 (e) surrenders any such naval establishment, or any part of such establishment to the enemy when it is capable of being successfully defended or when it is his duty to cause it to be destroyed ;
- shall, if the offence is committed with intent to assist the enemy, be liable to death or any less punishment authorised by this Act, and in any other case shall be liable to imprisonment for any term or to any less punishment provided by this Act.
- 30

- 35 34. Any person, who not being in command of any ship, vessel, aircraft or shore establishment of the navy, fails when ordered to prepare for action by or against the enemy, or during any such action, to use his utmost exertions to carry the lawful orders of his superior officers into execution shall, if the offence is committed with intent to assist the enemy, be liable to death or any less punishment authorised by this Act, and in any other case shall be liable to imprisonment or to any less punishment provided by this Act. Misconduct in action by other officers and ratings.

- 40 35. Any person who wilfully delays or discourages, upon any pretext whatsoever, any action or service which has been commanded on the part of any of the armed forces of Nigeria, or of any forces co-operating therewith shall, if the offence is committed with intent to assist the enemy, be liable to death or any less punishment authorised by this Act, and in any other case, shall be liable to imprisonment for any term or to any less punishment provided by this Act. Obstruction of operations.
- 45

Corresponding with, supplying or serving with the enemy.

36. Any person who—

- (a) communicates with or gives intelligence to the enemy ;  
 (b) fails to make known to the proper authorities any information received by him from the enemy ;  
 (c) furnishes the enemy with supplies of any description ; or  
 (d) having been made a prisoner of war, serves with or aids the enemy in the prosecution of hostilities or of measures calculated to influence morale, or in any other manner whatsoever not authorised by international usage ;

shall, if the offence is committed with intent to assist the enemy, be liable to death or any less punishment authorised by this Act, and in any other case, shall be liable to dismissal with disgrace from the armed forces of Nigeria or to any less punishment provided by this Act.

Wilful neglect and failure to rejoin forces, etc.

37.—(1) Any person who, through disobedience to orders or wilful neglect of his duty, is captured by the enemy shall be guilty of an offence against this section.

(2) Any person who, having been captured by the enemy, fails to take, or prevents or discourages any other person subject to service law who has been captured by the enemy from taking, any reasonable steps to rejoin the armed forces of Nigeria which are available to him or, as the case may be, to that other person shall be guilty of an offence against this section.

(3) Any person guilty of an offence against this section shall, on conviction by court martial, be liable to imprisonment or to any less punishment provided by this Act.

Offences against morale.

38. Any person who—

(a) spreads (whether orally, in writing, by signal or otherwise) reports relating to operations of the armed forces of Nigeria, or of any forces co-operating therewith, or of any part of any of those forces, being reports calculated to create despondency or unnecessary alarm ; or

(b) when before the enemy, uses words calculated to create despondency or unnecessary alarm,

shall, on conviction by court martial, be liable to imprisonment or to any less punishment provided by this Act.

Sleeping on watch or abandoning post.

39.—(1) Any person who, being in the presence or vicinity of the enemy or under orders to be prepared for action by or against the enemy, abandons his post improperly or sleeps upon his watch shall, on conviction by court martial, be liable to imprisonment for any term or to any less punishment authorised by this Act.

(2) Any person who, not being in the presence or vicinity of the enemy or under such orders as aforesaid, abandons his post improperly or sleeps upon his watch shall, on conviction by court martial, be liable to imprisonment for a term not exceeding two years or to any less punishment provided by this Act.

Neglect of duty.

40. Any person who neglects to perform or negligently performs any duty imposed on him shall be liable to dismissal with disgrace from the armed forces of Nigeria or to any less punishment provided by this Act.

*Mutiny*

41. In this Act "mutiny" means a combination between two or more persons subject to service law, or between persons two at least of whom are subject to service law—

Definition of mutiny.

5 (a) to overthrow or resist lawful authority in any of the armed forces of Nigeria or any forces co-operating therewith, or in any part of any of the said forces ;

10 (b) to disobey such authority in such circumstances as to make the disobedience subversive of discipline, or with the object of avoiding any duty or service against, or in connection with operations against, the enemy ; or

(c) to impede the performance of any duty or service in any of the armed forces of Nigeria or in any forces co-operating therewith, or in any part of any of the said forces.

15 42.—(1) Any person who—

Offences of mutiny.

(a) takes part in a mutiny involving the use of violence or the threat of the use of violence, or having as its object or one of its objects the refusal or avoidance of any duty or service against, or in connection with operations against the enemy or the impeding of the performance of any such duty or service ; or

20 (b) incites any person subject to service law to take part in such a mutiny, whether actual or intended, shall, on conviction by court martial, be liable to suffer death or any other punishment provided by this Act.

25 (2) Any person who takes part in any other form of mutiny or incites some other person subject to service law to take part therein whether such form of mutiny is actual or intended, shall be liable to imprisonment for any term or to any less punishment provided by this Act.

30 43. Any person who, knowing that a mutiny is taking place or is intended—

Failure to suppress mutiny.

(a) fails to use his utmost endeavours to suppress or prevent it, or

(b) fails to report without delay that the mutiny is taking place or is intended ;

35 shall, if the offence is committed with intent to assist the enemy, be liable, on conviction by court martial, to death or any less punishment authorised by this Act, and in any other case shall be liable to imprisonment for any term or to any less punishment provided by this Act.

*Insubordination and Similar Offences*

40 44. Any person who strikes or otherwise uses violence to, or offers violence to, his superior officer, whether or not that officer is exercising authority as such, shall, on conviction by court martial, be liable to imprisonment for any term or to any less punishment provided by this Act.

Striking superior officer.

45 45. Any person who—

(a) wilfully disobeys any lawful command of his superior officer (by whatever means communicated to him) ; or

Disobedience or threatening superior officer.

(b) uses threatening or insulting language to, or behaves with contempt to, his superior officer,

shall, on conviction by court martial, be liable to imprisonment or to any less punishment provided by this Act; but if the offence was not committed on active service or did not involve the striking or other use of violence, or offering of violence, to a superior officer exercising authority as such, a sentence of a term of imprisonment shall not exceed two years.

46. Any person who—

(a) fights or quarrels with any other person, whether subject to this Act or not; or

(b) uses threatening, abusive, insulting or provocative words or behaviour likely to cause a disturbance,

shall, on conviction by court martial, be liable to imprisonment for a term not exceeding two years, or to any less punishment provided by this Act.

47. Any person who—

(a) obstructs; or

(b) when called on, refuses to assist,

any person known to him to be a provost officer, or to be a person (whether subject to this Act or not) lawfully exercising authority under or on behalf of a provost officer shall, on conviction by court martial, be liable to imprisonment for a term not exceeding two years or to any less punishment provided by this Act.

48.—(1) Any person who contravenes or fails to comply with any provision of orders to which this section applies, being a provision known to him, or which he might reasonably be expected to know, shall, on conviction by court martial, be liable to imprisonment for a term not exceeding two years or to any less punishment provided by this Act.

(2) This section applies to naval regulations, standing orders or memoranda, captain's or departmental orders or routine orders of a continuing nature.

#### *Desertion and Absence without Leave*

49.—(1) Any person who—

(a) deserts; or

(b) persuades or procures any person subject to service law to desert,

shall, on conviction by court martial, be liable to imprisonment or to any less punishment provided by this Act; but a person shall not be liable to imprisonment for more than two years unless—

(a) if the offence was against paragraph (a) of this subsection, he was on active service or under orders for active service at the time when it was committed; or

(b) if the offence was against paragraph (b) of this subsection, the person in relation to whom it was committed was on active service or under orders for active service at that time.

Fighting and quarrelling.

Obstruction of provost officers.

Obedience and standing.

(2) In addition to or in lieu of any punishment authorised by subsection (1) of this section, the court martial by whom a rating is convicted of desertion may direct that the whole or part of his service previous to the period as respects which he is convicted of having been a deserter shall, if he is not a reservist called out on permanent service, be forfeited.

(3) For the purposes of this Act a person deserts who—

(a) leaves any of the armed forces of Nigeria or, when it is his duty to do so, fails to join or rejoin any of those forces with (in either case) the intention, subsisting at the time of the leaving or failure or formed thereafter, of remaining permanently absent from his duty; or

(b) being an officer, enlists in or enters any other of the armed forces of Nigeria without having resigned his commission, or being a rating, enlists in or enters in any other of the armed forces of Nigeria without having been discharged from his previous enlistment; or

(c) absents himself without leave with intent to avoid serving at any place outside Nigeria or to avoid service or any particular service when before the enemy,

and references in this Act to desertion shall be construed accordingly.

50. Any person who—

(a) absents himself without leave; or

(b) persuades or procures any person subject to service law to absent himself without leave,

shall, on conviction by court martial, be liable to imprisonment for a term not exceeding two years or to any less punishment provided by this Act.

Absence without leave, etc.

51. Any person who—

(a) knowingly assists any person subject to service law to desert or absent himself without leave; or

(b) knowing that any person subject to service law has deserted or absented himself without leave, or is attempting to desert or absent himself without leave, fails to report that fact without delay, or fails to take any steps in his power to cause that person to be apprehended,

shall, on conviction by court martial, be liable to imprisonment for a term not exceeding two years or to any less punishment provided by this Act.

Assisting and conceal- ing desertion and absence without leave.

#### *Navigation and Flying Offences*

52. Any person who, either wilfully or by negligence—

(a) causes or allows to be lost, stranded or hazarded any ship or vessel in the Nigerian service, or

(b) causes or allows to be lost or hazarded any aircraft in the Nigerian service,

shall, on conviction by court martial be liable, if he acts wilfully or with wilful neglect, to imprisonment or to any less punishment provided by this Act, and in any other case shall be liable to imprisonment for a term not exceeding two years or to any less punishment provided by this Act.

Loss or hazarding ship or aircraft.

Dangerous flying, etc.

53. Any person who is guilty of any act or neglect in flying or in the use of any aircraft, or in relation to any aircraft or aircraft material, which causes or is likely to cause loss of life or bodily injury to any person shall, on conviction by court martial, be liable to imprisonment or any less punishment provided by this Act :

Provided that if the offender has not acted wilfully or with wilful neglect he shall not be liable to be imprisoned for more than two years.

Low flying.

54. Any person who, being the pilot of a Nigerian service aircraft, flies it at a height less than the height from time to time prescribed by regulations made by the board under this Act except while taking-off or alighting, or in such other situation as may be so prescribed shall, on conviction by court martial, be liable to imprisonment for a term not exceeding two years or to any less punishment provided by this Act.

Annoyance by flying.

55. Any person who, being the pilot of a Nigerian service aircraft, flies it so as to cause, or to be likely to cause, unnecessary annoyance to any person shall, on conviction by court martial, be liable to imprisonment for a term not exceeding two years or to any less punishment provided by this Act.

#### *Prize Offences*

Prize offences by commanding officers.

56. Any person who, being in command of a Nigerian service ship, vessel or aircraft—

(a) having taken any ship, vessel or aircraft as prize, fails to send to the most convenient High Court in his opinion, in Nigeria all the ship papers or aircraft papers, as the case may be, found on board ;

(b) unlawfully makes any agreement for the ransoming of any ship vessel, aircraft or goods taken as prize ; or

(c) in pursuance of any such agreement as aforesaid, or otherwise by collusion, restores or abandons any ship, vessel, aircraft or goods taken as prize,

shall, on conviction by court martial, be liable to imprisonment for a term not exceeding two years, or to any less punishment provided by this Act.

Other prize offences.

57. Any person who—

(a) strikes or otherwise ill-treats any person who is on board a ship, vessel or aircraft when taken as prize, or unlawfully takes from any such person anything in his possession ;

(b) removes out of any ship, vessel or aircraft taken as prize (otherwise than for safe keeping or for the necessary use and service of any of the armed forces of Nigeria) any goods not previously adjudged by a High Court in Nigeria to be lawful prize ; or

(c) breaks bulk on board any ship, vessel or aircraft taken as prize or detained in exercise of any belligerent right or under any enactment, with intent to embezzle or fraudulently misapply anything therein ;

shall, on conviction by court martial, be liable to imprisonment for a term not exceeding two years or to any less punishment provided by this Act.

## 58. Any person who—

Looting.

(a) steals from, or with intent to steal searches, the person of anyone killed or wounded in the course of warlike operations ; or

5 (b) steals any property which has been left exposed or unprotected in consequence of warlike operations ; or

(c) takes otherwise than for the service of the public any vehicle, equipment or stores abandoned by the enemy,

shall be guilty of looting and liable, on conviction by court martial, to imprisonment or to any less punishment provided by this Act.

10 *Other Offences in respect of Ships and Aircraft*

59. Any person who signs a certificate relating to any matter affecting the seagoing or fighting efficiency of any of the Nigerian service ships or vessels or any certificate relating to any of the Nigerian service aircraft or aircraft material without ensuring the accuracy of the certificate shall, on conviction by court martial, be liable to imprisonment for a term not exceeding two years or to any less punishment provided by this Act.

Inaccurate certification of ships, etc.

60. Any person who, being in command of any of the Nigerian service ships, vessels or aircraft, without lawful authority—

Improper carriage of goods.

20 (a) receives or permits to be received on board the ship, vessel or aircraft any goods or merchandise intended for disposal or delivery by way of trade or business (whether on his own account or on account of any other person), not being merchandise received in the course of salvage ; or

25 (b) agrees to carry any goods or merchandise on board the ship, vessel or aircraft in consideration of the payment of freight, or demands or receives any payment in respect of such carriage,

30 shall, on conviction by court martial, be liable to imprisonment for a term not exceeding two years or to any less punishment provided by this Act.

*Malingering and Drunkenness*

## 61. Any person who—

Malingering.

(a) falsely pretends to be suffering from sickness or disability ; or

35 (b) injures himself with intent thereby to render himself unfit or temporarily unfit for service, or causes himself to be injured by any other person with that intent ; or

(c) injures any other person subject to service law, at the instance of that other person, with intent thereby to render that other person unfit or temporarily unfit for service ; or

40 (d) with intent to render or keep himself unfit or temporarily unfit for service does or fails to do anything (whether at the time of the act or omission he is in hospital or not) whereby he produces, or prolongs or aggravates, any sickness or disability,

45 shall be guilty of malingering and shall, on conviction by court martial, be liable to imprisonment for a term not exceeding two years or to any less punishment provided by this Act.

50 62.—(1) Any person who is guilty of drunkenness, whether on duty or not, shall, on conviction by court martial, be liable to imprisonment for a term not exceeding two years or to any less punishment provided by this Act :

Drunkenness.

Provided that where the offence is committed by a rating not on active service or on duty, the sentence imposed shall not exceed imprisonment for a period of six months.

(2) For the purpose of this section a person is guilty of drunkenness if owing to the influence of alcohol or any drug, whether alone or in combination with any other circumstances, he is unfit to be entrusted with his duty or with any duty which he may be called upon to perform, or behaves in a disorderly manner or in any manner likely to bring discredit to the armed forces of Nigeria.

#### *Offences relating to Property*

Misapplication and destruction of public and service property.

63. Any person who—

(a) steals or fraudulently misapplies any public or service property, or is concerned in or connives at the stealing or fraudulent misapplication of any public or service property ; or

(b) receives or retains any public or service property knowing or having reason to believe it to have been stolen or to have been fraudulently misapplied ; or

(c) wilfully damages, or is concerned in the wilful damage of, any public or service property ; or

(d) by wilful neglect causes damage to any public or service property, shall, on conviction by court martial, be liable to imprisonment or to any less punishment provided by this Act.

Loss and waste of public and service property.

64. Any person who—

(a) loses any public or service property of which he has the charge or which has been entrusted to his care or which forms part of property of which he has the charge or which has been entrusted to his care ; or

(b) by negligence damages any public or service property of which he has the charge or which has been entrusted to his care or which forms part of the property of which he has the charge or which has been entrusted to his care ; or

(c) by negligence causes damage to any public or service property ; or

(d) fails to take proper care of any animal or bird used in the public service which is in his charge ; or

(e) makes away (by pawning or in any other way) with any naval decoration granted to him or any clothing, arms, ammunition or other equipment issued to him for his use for naval purposes, shall, on conviction by court martial, be liable to imprisonment for a term not exceeding two years or to any less punishment provided by this Act :

Provided that it shall be a defence for any person charged under paragraph (a) of this section with losing any property that he took reasonable steps for the care and preservation thereof.

Offences in relation to property of members of forces.

65. Any person who—

(a) steals or fraudulently misapplies any property belonging to a person subject to service law, or is concerned in or connives at the stealing or fraudulent misapplication of any such property ; or

(b) receives or retains any such property knowing or having reason to believe the same to have been stolen or to have been fraudulently misapplied ; or

- 5 (c) wilfully damages, or is concerned in the wilful damage of, any property belonging to a person subject to service law, shall, on conviction by court martial, be liable to imprisonment for a term not exceeding two years or to any less punishment provided by this Act.

*Offences relating to and by Persons in Custody*

- 10 66.—(1) Any person who, when an officer or rating or other person subject to naval law is under arrest—

Irregular  
arrest and  
confinement.

(a) unnecessarily delays the investigation of allegations against that officer, rating or other person or, as the case may be, his trial ; or

- 15 (b) fails to release, or effect the release of, that officer, rating or other person when it is his duty to do so, shall be guilty of an offence against this section.

- (2) Where any person (elsewhere in this section referred to as “the prisoner”) is committed to the custody of any provost officer or other officer, or any petty officer, and the person so committing the prisoner fails without reasonable cause to deliver—

(a) at the time of the committal, or

- 20 (b) if it is not practicable so to do at the time of the committal, then within twenty-four hours thereafter, to the person to whose custody the prisoner was committed, a report in writing signed by himself of the offence which the prisoner is alleged to have committed, he shall be guilty of an offence against this section.

- (3) Where a prisoner is committed to the charge of any person who is in command of a guard, and the guard commander fails without reasonable excuse to give to the officer to whom it is his duty to report, as soon as may be after he is relieved from his guard and any further duty or, if he is not sooner relieved, within twenty-four hours after the committal—

- 30 (a) a written statement containing so far as known to him, the name of the prisoner with particulars of the alleged offences, and the name and rank or other description of the officer or other person by whom the prisoner is alleged to have committed the offence ; and

- 35 (b) (if he has received it) the report required by subsection (2) of this section,  
he shall be guilty of an offence against this section.

- 40 (4) Any person guilty of an offence against this section shall, on conviction by court martial, be liable to imprisonment for a term not exceeding two years or to any less punishment provided by this Act.

- 45 67.—(1) Any person who wilfully allows to escape any person who is committed to his charge, or whom it is his duty to guard, shall, on conviction by court martial, be liable to imprisonment or to any less punishment provided by this Act.

Permitting  
escape and  
unlawful  
release of  
prisoners.

(2) Any person who—

(a) without proper authority releases any person who is committed to his charge ; or

(b) without reasonable excuse allows to escape any person who is committed to his charge, or whom it is his duty to guard, shall, on conviction by court martial, be liable to imprisonment for a term not exceeding two years or to any less punishment provided by this Act.

Resisting arrest.

68.—(1) Any person who, being concerned in any quarrel or disorder, refuses to obey any officer who orders him into arrest, or strikes or otherwise uses violence to, or offers violence to, any such officer, shall be guilty of an offence against this section whether or not the officer is his superior officer.

(2) Any person who strikes or otherwise uses violence to, or offers violence to, any person whose duty it is to apprehend him or in whose custody he is shall be guilty of an offence against this section.

(3) Any person guilty of an offence against this section shall, on conviction by court martial, be liable to imprisonment for a term not exceeding two years or to any less punishment provided by this Act.

Escape from confinement.

69. Any person who escapes from arrest, prison or other lawful custody (whether naval custody or not) shall, on conviction by court martial, be liable to imprisonment for a term not exceeding two years or to any less punishment provided by this Act.

*Offences in relation to Courts Martial and Civil Authorities*

Offences in relation to courts martial.

70.—(1) Any person who—

(a) having been duly summoned or ordered to attend as a witness before a court martial, fails to comply with the summons or order ; or

(b) refuses to swear an oath or make an affirmation when duly required by a court martial to do so ; or

(c) refuses to produce any document in his custody or under his control which a court martial has lawfully required him to produce ; or

(d) when a witness, refuses to answer any question which a court martial has lawfully required him to answer ; or

(e) wilfully insults any person, being a member of a court martial or a witness or any other person whose duty it is to attend on or before the court, while that person is acting as a member thereof or is so attending, or wilfully insults any such person as aforesaid while that person is going to or returning from the proceedings of the court ; or

(f) wilfully interrupts the proceedings of a court martial, or otherwise misbehaves before the court,

shall, on conviction by court martial, other than the court in relation to which the offence was committed, be liable to imprisonment for a term not exceeding two years or to any less punishment provided by this Act.

(2) Notwithstanding anything in subsection (1) of this section, where an offence against paragraph (e) or paragraph (f) of that subsection is committed in relation to any court martial held in pursuance of this Act that court, if of opinion that it is expedient that the offender should

be dealt with summarily by the court instead of being brought to trial before another court martial, may by order under the hand of the president of the court order the offender to be imprisoned for a period not exceeding twenty-one days.

- 5 (3) References in paragraphs (a) to (f) of subsection (1) of this section to a court martial shall include references to a court martial held in pursuance of service law.

71.—(1) Any person who, having been duly sworn as a witness or as an interpreter in proceedings before a court martial or before any board or person having power to administer an oath under service law, makes a statement material in those proceedings knowing it to be false or recklessly without belief in its truth shall, on conviction by court martial, be liable to imprisonment for a term not exceeding two years or to any less punishment provided by this Act.

False evidence.

- 15 (3) A person shall not be liable to be convicted of an offence against this section upon the evidence, sworn or unsworn, of one witness alone as to the truth or untruth of any statement alleged to be false.

72. Any person who at any place either within or outside Nigeria prevents or obstructs—

Obstruction of police officer arresting officer or rating.

- 20 (a) the execution by a police officer of a warrant for the arrest of a person subject to service law who has committed or is suspected of having committed an offence punishable on conviction by a civil court; or

25 (b) the arrest of a person subject to service law by a police officer acting in the exercise of his powers of arrest without warrant, shall, on conviction by court martial, be liable to imprisonment for a term not exceeding two years or to any less punishment provided by this Act.

#### *Miscellaneous Offences*

- 30 73.—(1) Any person who without authority discloses, by any means whatsoever, information which is or purports to be information useful to an enemy shall, on conviction by court martial, be liable to imprisonment for a term not exceeding two years or to any less punishment provided by this Act.

Injurious disclosures.

- 35 (2) In this section the expression “information useful to an enemy” means information as to any matter such that information as to it would or might be directly or indirectly useful to an enemy, and in particular (but without prejudice to the generality of the foregoing provisions of this subsection) information as to any matter falling within
- 40 the following paragraphs, being a matter such that information as to it would or might be useful as aforesaid, that is to say—

45 (a) the number, description, armament, equipment, disposition, movement or condition of any of the armed forces of Nigeria or of any forces co-operating therewith, or any of Nigerian ships or aircraft or of the ships or aircraft of any such co-operating force; or

(b) any operations or projected operations of any of such forces, ships or aircraft as aforesaid; or

(c) any code, cipher, call sign, password or countersign; or

50 (d) any measures for the defence or fortification of any place on behalf of Nigeria; or

(e) the number, description or location of any prisoners of war; or

(f) munitions of war.

Making of false statements on enlistment.

74. Any person who, when before a recruiting officer for the purpose of being attested in pursuance of Part III of this Act has knowingly made a false answer to any question contained in the attestation paper and put to him by or by the direction of the recruiting officer shall, on conviction by court martial, if he is subject to naval law, be liable to imprisonment for a term not exceeding three months or to any less punishment provided by this Act.

Scandalous conduct of officer.

75. Every officer who behaves in a scandalous manner, unbecoming the character of an officer and a gentleman, shall, on conviction by court martial, be dismissed with disgrace from the armed forces of Nigeria.

Ill-treatment of officers or ratings of inferior rank.

76. If—

(a) any officer strikes or otherwise ill-treats any officer subject to service law of inferior rank or less seniority or any rating subject to service law ; or

(b) any petty officer strikes or otherwise ill-treats any person subject to service law, being a rating of inferior rank or less seniority, any such officer shall, on conviction by court martial, be liable to imprisonment for a term not exceeding two years or to any less punishment provided by this Act.

Disgraceful conduct.

77. Any person who is guilty of disgraceful conduct of a cruel, indecent or unnatural kind shall, on conviction by court martial, be liable to imprisonment for a term not exceeding two years or to any less punishment provided by this Act.

False accusation.

78. Any person who—

(a) makes an accusation against any officer or rating subject to service law, knowing it to be false or recklessly without belief in its truth ; or

(b) in making a complaint where he thinks himself wronged, makes a statement affecting the character of an officer or rating subject to service law, knowing it to be false or recklessly without belief in its truth, or wilfully suppresses any material facts, shall, on conviction by court martial, be liable to imprisonment for a term not exceeding two years or to any less punishment provided by this Act.

Conduct to prejudice of naval discipline.

79. Any person who is guilty of any conduct or neglect to the prejudice of good order and naval discipline shall, on conviction by court martial, be liable to imprisonment for a term not exceeding two years or to any less punishment provided by this Act.

Attempts commit naval offences.

*Attempts and Aiding and Abetting of Naval Offences*

80. Any person who attempts to commit an offence against any of the foregoing provisions of this Part of this Act shall, on conviction by court martial, be liable to the like punishment as for that offence :

Provided that if the offence is one punishable by death he shall not be liable to any greater punishment than imprisonment.

Aiding and abetting naval offences.

81. Any person who aids, abets, counsels or procures the commission by another person of an offence against any of the provisions of this Act shall be guilty of the like offence and shall be liable to be charged, tried and punished as a principal offender.

*Civil Offences*

82.—(1) Any person who commits a civil offence within the meaning of this Act in Nigeria or elsewhere, shall be guilty of an offence against this section.

Civil offences.

5 (2) For the purposes of the foregoing subsection, the expression "civil offence" means any act or omission punishable as an offence under the penal provisions of any law enacted in or applicable to Nigeria, and "the corresponding civil offence" means the civil offence the commission of which constitutes the offence against this section.

10 (3) Subject to the next succeeding subsection, a person convicted by court martial of an offence against this section shall—

(a) if the corresponding civil offence is treason or murder he liable to suffer death, and

15 (b) in any other case, be liable to suffer the punishment which a civil court might award for the corresponding civil offence, if committed anywhere in Nigeria, being a punishment provided by this Act, or such lesser punishment which a civil court could so award, as is so provided.

20 (4) Where a court other than a court martial may not award a term of imprisonment for a civil offence, a person convicted of a civil offence shall be liable to suffer such punishment, less than dismissal with disgrace in the case of an officer, or discharge with ignominy in the case of a rating, as is prescribed for the civil offence.

25 (5) Nothing in this section shall be construed to authorise the charging of a person with an offence against this section committed in Nigeria if the corresponding civil offence is treason, murder, manslaughter, treasonable felony or rape; and for the purposes of this subsection where the corresponding civil offence is murder or manslaughter an offence against this section shall be deemed to have been  
30 committed at the place of the commission of the act or occurrence of the negligence which caused the death, irrespective of the place of the death.

*Punishments*

83.—(1) The punishments which may be awarded to an officer by sentence of a court martial under this Act are, subject to the limitations hereinafter provided on the powers of certain courts martial, those set out in the following scale; and in relation to an officer, references in this Act to punishments provided by this Act are references to those punishments.

Punishment of officers

(2) The said scale is—

35 (a) death;

40 (b) imprisonment;

(c) dismissal with disgrace from the armed forces of Nigeria;

(d) dismissal from the armed forces of Nigeria;

(e) forfeiture of seniority;

(f) a fine of a sum not exceeding the equivalent of ninety days' pay;

45 (g) severe reprimand or reprimand;

(h) stoppages, where the offence has occasioned any expense, loss or damage.

(3) For the purposes of this Part of this Act, a punishment specified in any paragraph of the said scale shall be treated as less than the punishment specified in the preceding paragraphs, and greater than those specified in the following paragraphs, of the scale.

(4) Save as expressly provided in this Act, not more than one punishment shall be awarded by a court martial for one offence.

(5) Stoppages may be awarded by a court martial either in addition to or without any other punishment.

(6) A severe reprimand or reprimand may be awarded by a court martial in addition to a fine.

(7) Where an officer is sentenced by a court martial to imprisonment, he shall also be sentenced to be dismissed with disgrace from the armed forces of Nigeria :

Provided that if the court martial fails to sentence him to be so dismissed, the sentence of imprisonment shall not be invalid, but shall be deemed to include a sentence of dismissal with disgrace.

Punishment  
of ratings.

84.—(1) The punishment which may be awarded to a rating by sentence of a court martial under this Act are, subject to the limitations hereinafter provided on the powers of certain courts martial, those set out in the following scale ; and in relation to a rating reference in this Act to punishments provided by this Act are references to those punishments.

(2) The said scale is—

(a) death ;

(b) imprisonment ;

(c) dismissal with disgrace from the armed forces of Nigeria ;

(d) dismissal from the armed forces of Nigeria ;

(e) disrating to any rate not lower than that in which the rating was enlisted ;

(f) a fine of a sum not exceeding the equivalent of ninety days' pay ;

(g) in the case of a chief petty officer or petty officer, severe reprimand or reprimand ;

(h) where the offence is desertion ; forfeiture of service ;

(i) stoppages, where the offence has occasioned any expense, loss or damage.

(3) For the purposes of this Part of this Act, a punishment specified in any paragraph of the said scale shall be treated as less than the punishments specified in the preceding paragraphs, and greater than those specified in the following paragraphs, of the scale.

(4) Notwithstanding the provisions of subsections (1) and (2) of this section, a court martial may, where it thinks fit, award any punishment specified in the First Schedule to this Act, being a punishment not already specified in subsection (2) of this section ; and where a court martial awards any such punishment the qualification (if any) specified in the said Schedule in respect of such punishment shall not apply.

(5) Save as expressly provided in this Act, not more than one punishment shall be awarded by a court martial for one offence.

First  
Schedule.

(6) A rating sentenced by a court martial to imprisonment may in addition thereto be sentenced to be discharged with ignominy from the armed forces of Nigeria.

(7) Where any rating is sentenced by a court martial to imprisonment he shall also be sentenced to be disgraced to the rate in which he enlisted :

Provided that if the court martial fails to sentence him to be so disgraced the sentence shall not be invalid but shall be deemed to include a sentence of disgracing.

(8) In the case of a rating, a severe reprimand or reprimand may be awarded by a court martial in addition to a fine.

(9) Stoppages may be awarded by a court martial either in addition to or without any other punishment.

#### *Arrest*

15 **85.**—(1) Any person found committing an offence against any provision of this Act, or alleged to have committed or reasonably suspected of having committed any such offence, may be arrested in accordance with the following provisions of this section.

Power to  
arrest  
offenders.

20 (2) An officer may be arrested by an officer subject to service law of superior rank, or, if engaged in a quarrel or disorder, by such an officer of any rank.

(3) A rating may be arrested by an officer or another rating subject to service law but no rating shall be arrested under this subsection except by a person of superior rank.

25 (4) A provost officer, or any officer, warrant officer, non-commissioned officer, rating, soldier or airman subject to service law lawfully exercising authority under a provost officer or on his behalf, may arrest any officer or rating ; but no officer shall be arrested under this subsection except on the order of another officer.

30 (5) The power of arrest given to any person by this section may be exercised either personally or by ordering into arrest the person to be arrested or by giving orders for that person's arrest.

35 **86.**—(1) The allegations against any person who is under arrest shall be duly investigated without unnecessary delay, and as soon as may be, either proceedings shall be taken for punishing his offence or he shall be released from arrest.

Provisions  
for avoiding  
delay after  
arrest.

40 (2) If any person taken into naval custody remains under arrest for a longer period than eight days without a court martial for his trial being assembled, a special report on the necessity for further delay shall be made by his commanding officer as may be prescribed and a similar report shall be made not later than every eight days thereafter (whichever event happens first) until a court martial is assembled or the offence is dealt with summarily or the person is released from arrest :

45 Provided that in the case of a person on active service compliance with this subsection shall be excused in so far as it is not reasonably practicable having regard to the exigencies of naval operations.

(3) For the purposes of subsection (1) of section sixty-six, the question whether there has been unnecessary delay in the investigation of allegations against a person under arrest shall be determined without regard to the provisions of subsection (2) of this section.

*Investigation of and Summary Dealing with Charges*

5

Investigation of charges by commanding officer.

87. Before an allegation against a person that he has committed an offence against any provision of this Part of this Act is further proceeded with, the allegation shall be reported in the form of a charge to the commanding officer, where the person charged is an officer, or to the officer of the watch, or the officer of the day or the executive officer, as the case may be, where the person charged is a rating, and the officer to whom the charge is reported shall investigate the charge in the prescribed manner.

10

Summary trial of officers.

88.—(1) If an officer of the navy or of the reserve below the rank of commander is charged with an offence to which this section applies, the commander may, if it appears to him that the offence is not of such a nature as to necessitate trial by court martial, and subject to the provisions of this section and of any orders made thereunder, deal with the charge summarily. If he records a finding of guilty, he may award one or more of the following punishments, that is to say—

15

(a) a fine not exceeding twenty-five days' pay ;

(b) severe reprimand or reprimand ;

(c) stoppages, where the offence has occasioned any expense, loss or damage.

20

(2) This section applies to any offence triable by court martial under this Act other than offences under the following provisions of this Act, that is to say—

25

(a) sections thirty-three, thirty-four, thirty-five, thirty-six, thirty-nine, forty-two, forty-three, fifty-six, fifty-seven, fifty-eight, sixty-three, seventy-three, seventy-seven, and eighty-two ;

30

(b) sections eighty and eighty-one, so far as they are applicable to an offence under any of the provisions mentioned in paragraph (a) of this subsection.

(3) Notwithstanding anything in subsection (1) of this section, where the commander has determined that the person charged is guilty and if the charge is dealt with summarily will award a fine or stoppages, the commander shall not record a finding until after affording such person an opportunity of electing to be tried by court martial ; and if such person so elects, the commander shall not record a finding but shall take the prescribed steps with a view to the charge being tried by court martial.

35

40

(4) The commander may by order direct that the powers conferred upon him by this Act to investigate charges against officers and try and punish officers summarily may be exercised by officers not below the rank of captain.

45

Summary trial of ratings.  
First Schedule.

89.—(1) Subject to the provisions of this section, a rating who is charged with an offence to which this section applies may be summarily tried and punished to the extent permitted and in accordance with the First Schedule to this Act by the officer in command of the ship or establishment to which the rating belongs either at the time of the commission of the offence or at the time of the trial thereof.

50

(2) Where an officer holding a post specified in the First Schedule has been absent from his post on duty or approved leave for more than ninety-six hours continuously or has otherwise ceased to carry out his duties through sickness or any other cause, any officer temporarily authorised to carry out the duties of the post may while so authorised exercise the same powers of punishment as may be exercised by the substantive holder of the post, and the said First Schedule shall be construed accordingly.

(3) The power conferred by subsection (1) of this section on the officer in command of a ship or naval establishment may, subject to any rules made under this Act, be exercised—

(a) in respect of persons on board a single tender or boat which is absent from the ship or establishment on detached service by the officer in command of that tender or boat ;

(b) in respect of persons on board one of two or more tenders or boats which are absent as aforesaid on detached service in company or acting together, by the officer in immediate command of those tenders or boats ; and

(c) in respect of other persons absent from the ship or establishment on detached service either on shore or elsewhere, by the officer in immediate command of those persons.

(4) The power conferred on any officer by subsection (1) or subsection (3) of this section may, subject to such conditions as may be prescribed be delegated to any officer not below the rank of lieutenant or corresponding rank.

(5) The President may by order amend the First Schedule.

(6) This section applies to any offence triable by court martial under this Act, other than an offence punishable by sentence of death.

90.—(1) Any charge not dealt with summarily shall after investigation be remanded for trial by court martial.

(2) Notwithstanding anything in the foregoing provisions of this section, where an officer has investigated a charge he may dismiss the charge if he is of the opinion that it ought not to be proceeded with.

(3) References in this Act to dealing summarily with a charge are references to the taking by the officer authorised, as the case may require, of the following action, that is to say, determining whether the accused is guilty, dismissing the charge or recording a finding of guilty accordingly, and awarding punishment.

#### *Courts Martial : General Provisions*

91. A court martial may try any person subject to naval law under this Act for any offence under Part IV of this Act and award any punishment authorised by this Act for that offence and, subject to the provisions of subsections (4) and (5) of section eighty-two, a court martial shall have jurisdiction to try any such offence whether committed within Nigeria or elsewhere.

92.—(1) The commander shall have the power to convene a court martial.

(2) Where the commander is absent from his post on duty or approved leave for more than ninety-six hours continuously or has otherwise ceased to carry out his duties through sickness or any other cause, any officer, temporarily authorised to carry out the duties of the commander, shall have the power to convene a court martial.

Charges to be dealt with summarily or by court martial.

Jurisdiction of courts martial.

Officers having power to convene courts martial.

Composition  
of courts  
martial.

(3) The senior officer of a detached unit or squadron may be authorised by the board to order a court martial in special circumstances.

93.—(1) A court martial shall consist of not less than three nor more than nine officers, being officers of or seconded to the navy and subject to service law who are of or above the rank of lieutenant in the navy. 5

(2) An officer shall not be appointed to be a member of a court martial unless he has held a commission in any of the armed forces of Nigeria for a period of not less than two years or for periods amounting in the aggregate to not less than two years. 10

(3) The members of a court martial and such spare members as the convening officer considers appropriate for the purpose of filling vacancies, shall be nominated by the convening officer.

(4) The president of a court martial shall not be below the rank of commander. 15

(5) A court martial for the trial of a commander shall include at least two members in addition to the president, who are not below the rank of commander.

(6) If a court martial is to be convened at any place where in the opinion of the convening officer the necessary number of naval officers having suitable qualifications is not available to form the court, and cannot be made available with due regard to the circumstances, the convening officer may, with the consent of the proper military or air force authority, appoint any military or air force officer as president in lieu of a naval officer or as any other member of the court in lieu of or in addition to a naval officer or officers : 20 25

Provided that no military or air force officer shall be qualified to act in relation to a court martial unless he is of corresponding rank to that which would have been required in the case of a naval officer and has held a commission in any of the armed forces of Nigeria for the like period or periods as would have been so required. 30

(7) Where the officer convening any court martial appoints an officer not being a naval officer as president or any other member of the court, being of opinion that the necessary number of naval officers having suitable qualifications is not available to form the court and cannot be made available with due regard to the circumstances, the order convening the court martial shall contain a statement of the said opinion, and that statement shall be conclusive. 35

(8) The officer who convenes a court martial shall not be a member of that court martial ; and no court martial shall consist of officers all of whom belong to the same ship or naval establishment. 40

(9) An officer who, at any time between the date on which the accused was charged with the offence and the date of the trial, has investigated the charge against the accused, or who under service law has held, or acted as one of the persons holding, an inquiry into matters relating to the subject matter of the charge against the accused, shall not sit as a member of a court martial or act as judge advocate at such a court martial. 45

(10) A court martial for the trial of an officer shall consist of at least five officers. 50

(11) A court martial consisting of less than five officers shall not award any punishment higher in the scale of punishments than imprisonment for two years.

(12) Unless it consists of at least five officers, a court martial shall not try any offence for which the maximum or only punishment is death.

94. Without prejudice to the powers conferred by the President on the Judge Advocate General, the appointment of a judge advocate to act in any court martial may, failing the making thereof by or on behalf of the Judge Advocate General, be made by the convening officer.

Appointment  
of judge  
advocate.

95.—(1) A court martial shall be held on board such of the Nigerian ships or vessels, or such premises on shore, whether within or without Nigeria as may be specified in the order convening the court.

Place and  
time for sit-  
ting of courts  
martial.

(2) If it appears to a court martial to be expedient in the interests of justice the court may be adjourned, either generally or for the purpose of any part of the proceedings, to any other ship, vessel or place and shall, if so required by the convening officer, be adjourned to any other ship, vessel or place appointed by that officer.

(3) Without prejudice to the provisions of subsection (2) of this section, a court martial may, if it appears to the court that an adjournment is desirable for any reason, be adjourned for such period as the court thinks fit:

Provided that except with the consent of the accused and the prosecutor the period for which the court may be adjourned under this subsection shall not on any occasion exceed six days.

(4) Subject to the provisions of this section, a court martial shall, unless prevented by weather or other unavoidable cause, sit from day to day until the court has arrived at a finding and, in the case of a conviction, until sentence is pronounced; but the court shall not sit on a Sunday, or any day that is a public holiday, unless, in the opinion of the court or of the convening officer, exigencies of the service make it necessary to do so.

96.—(1) Where, whether before or after the commencement of the trial, it appears to the convening officer necessary or expedient in the interests of the administration of justice that a court martial should be dissolved, the convening officer may by order dissolve the court martial.

Dissolution  
of court  
martial.

(2) Without prejudice to the generality of subsection (1) of this section, if after the commencement of the trial a court martial is, by reason of the death of one of the members or for any other reason, reduced below the legal minimum, it shall be dissolved.

(3) The proceedings of a court martial shall be valid notwithstanding the absence of one or more of the members other than the president, so long as the number of members present throughout the proceedings is not reduced below the legal minimum:

Provided that a member of the court who has been absent for any time during a sitting shall take no further part in the proceedings.

(4) If after the commencement of the trial the president dies or is otherwise unable to attend and the court is not reduced below the legal minimum, then—

(a) if the senior member of the court is of the rank of lieutenant-commander or corresponding rank or is of higher rank, the convening officer may appoint him president and the trial shall proceed accordingly; but

(b) if he is not, the court shall be dissolved.

(5) Without prejudice to the generality of subsection (1) of this section, if after the commencement of the trial it is represented to the convening officer that owing to the sickness or other incapacity of the accused it is impracticable having regard to all the circumstances to continue the trial within a reasonable time, the convening officer may dissolve the court.

(6) Where a court martial is dissolved under the foregoing provisions of this section the accused may be tried by another court martial.

Challenges  
by accused.

97.—(1) An accused about to be tried by a court martial shall be entitled to object, on any reasonable grounds, to any member of the court, whether appointed originally or in lieu of another officer.

(2) For the purpose of enabling the accused to avail himself of the right conferred by subsection (1) of this section the names of the members of the court shall be read over in the presence of the accused before they are sworn, and he shall be asked whether he objects to any of those officers.

(3) Every objection made by an accused to any officer shall be considered by the other officers appointed members of the court.

(4) If objection is made to the president and not less than one-third of the other members of the court allow it, the court shall adjourn and the convening officer shall appoint another president.

(5) If objection is made to a member of the court other than the president and not less than one-half of the members entitled to vote allow it, the member objected to shall retire and the vacancy may, and if otherwise the number of members would be reduced below the legal minimum shall, be filled in the prescribed manner by another officer.

Admini-  
stration of  
oaths.

98.—(1) An oath shall be administered separately to every member of a court martial and to any person in attendance on a court martial as judge advocate, the clerk of the court, officer under instruction, shorthand writer or interpreter.

(2) Every witness before a court martial shall be examined on oath:

Provided that where any child called as a witness does not in the opinion of the court understand the nature of an oath, his evidence may be received, though not given on oath, if in the opinion of the court he is possessed of sufficient intelligence to justify the reception of the evidence and understands the duty of speaking the truth, so however that, where the evidence is given on behalf of the prosecution, the accused shall not be liable to be convicted upon such evidence alone unless it is corroborated by some other material evidence in support thereof implicating the accused.

(3) A person shall be permitted to make a solemn affirmation instead of taking an oath under this section—

(a) if he objects to being sworn, and states as the grounds of his objection either that he has no religious belief or that the taking of an oath is contrary to his religious belief; or

(b) if it is not reasonably practicable to administer an oath to him in the manner appropriate to his religious belief.

(4) An oath or affirmation required to be administered under this section shall be in the form prescribed by the Oaths Act, 1963, or if no form is so prescribed, as near thereto as may be in any particular case, and shall be administered accordingly.

99.—(1) Subject to the provisions of this section, a court martial shall sit in open court and in the presence of the accused.

Courts martial to sit in open court.

(2) Nothing in subsection (1) of this section shall affect the power of a court martial to sit in camera on the ground that it is necessary or expedient in the interests of the administration of justice to do so; and  
5 without prejudice to that power a court martial may order that, subject to any exceptions the court may specify, the public shall be excluded from all or any part of the proceedings of the court if it appears to the court that any evidence to be given or statement to be made in the course of the  
10 proceedings or that part, as the case may be, might otherwise lead to the disclosure of any information which would or might be directly or indirectly useful to an enemy.

(3) A court martial shall sit in closed court while deliberating on its findings or sentence on any charge.

(4) A court martial may sit in closed court on any other deliberation  
15 amongst the members.

(5) Where a court martial sits in closed court no person shall be present except the members of the court and such other persons as may be prescribed.

100.—(1) Subject to the provisions of this section, every question to be determined on trial by court martial shall be determined by a majority of the votes of the members of the court.

Decisions of courts martial.

(2) In the case of an equality of votes on the finding, the court shall acquit the accused.

(3) A finding of guilty where the only punishment which the court  
25 is empowered to award is death shall not have effect unless it is reached with the concurrence of all members of the court; and where there is such a finding but no such concurrence, the court shall be dissolved and the accused may be tried by another court.

(4) Where the accused is found guilty and the court has power to  
30 sentence him either to death or to some less punishment, sentence of death shall not be passed without the concurrence of all the members of the court.

(5) In the case of an equality of votes on the sentence or on any  
35 question arising after the commencement of a trial, except the findings, the president shall have a second or casting vote.

101.—(1) Without prejudice to the provisions of section ninety-nine of this Act the finding of a court martial on each charge shall be announced in open court; and where the finding of that court is one of guilty the finding shall be, and be announced as being, subject to confirmation.  
40

Finding and sentence.

(2) The sentence of a court martial together with any recommendation to mercy shall be announced in open court, and shall be, and be announced as being, subject to confirmation.

102.—(1) Any person charged before a court martial with an offence  
45 under this Act may, on failure of proof of the offence having been committed under circumstances involving a higher degree of punishment, be found guilty of the offence as having been committed under circumstances involving a less degree of punishment.

Power to convict of offence other than that charged.

(2) Any person charged before a court martial with any offence may be found guilty of attempting to commit that offence.

(3) Any person charged before a court martial with attempting to commit an offence may be convicted on that charge notwithstanding that it is proved that he actually committed the offence.

(4) Where a person is charged before a court martial under section eighty-two of this Act in respect of attempting to commit a civil offence, he may be convicted on that charge notwithstanding that it is proved that he actually committed the civil offence.

(5) Where a person is charged before a court martial with an offence against section eighty-two of this Act and the corresponding civil offence is one in proceedings for which, if he had been tried by a civil court for committing the offence in Nigeria, he might have been found guilty of another civil offence, then if the court finds that he has committed that other civil offence he may be convicted of an offence against the said section eighty-two in respect of the commission of that other civil offence.

(6) Any person charged before a court martial with an offence specified in the first column of the Second Schedule to this Act may be found guilty of an offence specified in relation thereto in the second column of that schedule.

Rules of  
evidence.

103.—(1) Unless otherwise prescribed, the rules of evidence to be observed in proceedings before a court martial shall, for the avoidance of doubt, be the same as those observed in the High Court of Lagos; and accordingly no person shall in proceedings before a court martial be required to answer questions or produce documents which he could not be required to answer or produce in similar proceedings before that Court.

(2) Notwithstanding anything in the last foregoing subsection, a statutory declaration shall, in a trial by court martial, be admissible as evidence of the fact stated therein in a case where and to the extent to which oral evidence to the like effect would be admissible in that trial; but no statutory declaration shall be admitted in evidence—

(a) if such declaration is tendered on behalf of the prosecution, unless a copy of such declaration has not less than seven days before the commencement of the trial been served on the accused; or

(b) if such declaration is tendered on behalf of the defence, unless a copy of such declaration has not less than seven days or such lesser period as the commanding officer may allow before the commencement of the trial been served on the commanding officer of the accused; or

(c) in any case, if, not later than three days before the commencement of the trial or within such extended time as the court martial may in the circumstances of the case allow, notice in the prescribed form is served on the accused or, as the case may be, the commanding officer of the accused, requiring oral evidence to be given in substitution for that contained in the statutory declaration; or

(d) in any case, if the court martial is of opinion that it is desirable in the interests of justice for oral evidence to be given.

(3) Every court martial shall take judicial notice of all matters of notoriety, including matters within the general service knowledge of the court and of all other matters of which judicial notice would be taken in the High Court of Lagos.

104. A witness before a court martial and any other person required to attend such court shall have and be entitled to the same immunities and privileges as are accorded to witnesses in the High Court of Lagos.

Privileges of witnesses and others at courts martial.

5 105.—(1) Any person, whether subject to this Act or not, who is required to give evidence before a court martial may be summoned by notice in writing given by order of the convening officer.

Summoning of witnesses.

(2) Any person not subject to this Act who attends a court martial in pursuance of a notice under this section shall be entitled to receive such expenses of his attendance as may be prescribed.

10 106.—(1) Where in Nigeria any person other than a person subject to this Act—

Offences by civilians in relation to courts martial.

(a) having been duly summoned to attend as a witness before a court martial, fails to comply with the summons; or

15 (b) refuses to swear on oath when duly required by a court martial to do so; or

(c) refuses to produce any document in his custody or under his control which a court martial has lawfully required him to produce; or

(d) when a witness, refuses to answer any question which a court martial has lawfully required him to answer; or

20 (e) wilfully insults any person, being a member of a court martial or a witness or any other person whose duty it is to attend on or before a court martial, while that person is acting as a member thereof or is so attending, or wilfully insults any such person as aforesaid while that person is going to or returning from the proceedings of a court martial; or

(f) wilfully interrupts the proceedings of a court martial or otherwise misbehaves before the court; or

25 (g) does any other thing which would, if the court martial had been a court of law having power to commit for contempt, have been contempt of that court,

30 the president of the court martial may certify the offence of that person under his hand to the High Court having jurisdiction in that part of Nigeria where the offence is alleged to have been committed or in the place where the offender is to be found, and the High Court may there-  
35 upon inquire into the alleged offence and after hearing witnesses (if any) and taking any statement that may be offered in defence, punish or take steps for the punishment of that person in like manner as if he had been guilty of contempt of the court to which the offence is certified.

40 (2) A person shall not be dealt with under this section in respect of failure to comply with a summons requiring him to attend as a witness before a court martial unless any expenses to which he is entitled under this Act in respect of his attendance have been paid or tendered:

Provided that for the purposes of this subsection—

45 (a) the tender of a warrant or voucher entitling any person to travel shall be deemed to constitute tender of his expenses in respect of any travelling authorised by the warrant or voucher; or

(b) the tender of a written undertaking on behalf of the board to defray at the trial any other expenses to which such a person may be entitled under this Act in respect of his attendance shall be deemed to constitute tender of those expenses.

(3) In this section "court martial" means a court martial held under service law. 5

*Confirmation, Revision and Review of Proceedings of Courts Martial*

Confirmation of proceedings of court martial.

107.—(1) Where a court martial finds the accused guilty of any charge, the record of the proceedings of the court martial shall be transmitted to a confirming authority for confirmation of the finding and sentence of the court on that charge. 10

(2) Until it is so confirmed, the finding of guilty or, as the case may be, the sentence of a court martial, shall not be treated as the finding or sentence of such court; but nothing in this subsection shall be construed to prohibit the keeping of the accused in custody pending confirmation or revision of the finding or sentence or the consideration of any petition under this Act. 15

Petitions against finding or sentence.

108. At any time after a court martial has sentenced the accused, but not later than the prescribed time after promulgation of confirmation, the accused may, in the prescribed manner, present a petition against the finding or the sentence or both. 20

Revision of findings of court martial.

109.—(1) A confirming authority may direct that a court martial shall revise any finding of guilty come to by the court in any case where it appears to him— 25

(a) that the finding was against the evidence; or

(b) that some question of law determined at the trial and relevant to the finding was wrongly determined.

(2) Any such direction shall be accompanied by the necessary directions for the reassembly of the court, and shall contain a statement of the reasons for the direction. 30

(3) On any revision of a finding the court shall reconsider the finding, and (unless the court adheres thereto) may substitute therefor either a finding of not guilty or any other finding to which the court could originally have come at the trial in lieu of the finding under revision. 35

(4) On any such revision the court shall not have power to receive further evidence.

(5) Where on any such revision the court either adheres to the original finding or substitutes therefor a finding of guilty of another offence, or of the same offence in different circumstances, the court may substitute a different sentence for the original sentence: 40

Provided that the court shall not have power to substitute a sentence of a punishment greater than the punishment or the greatest of the punishments awarded by the original sentence, or to substitute a sentence which in the opinion of the court is more severe than the original sentence. 45

(6) The confirming authority shall not have power to direct the revision of any substituted finding of the court on a previous direction of a confirming authority, or the revision of the original finding if adhered to by the court on such a previous direction ; but save as aforesaid this Act shall apply to the proceedings of the court on any such revision (other than the requirement of announcement in open court) as it applies to their deliberation on the original finding or sentence, and any substituted finding or sentence shall be treated for all purposes as an original finding or sentence of the court.

10 **110.**—(1) Subject to the provisions of section one hundred and nine and to the following provisions of this section, a confirming authority shall deal with the finding or sentence of a court martial—

Powers of  
confirming  
authority.

15 (a) by withholding confirmation, if of the opinion that the finding of the court martial is unreasonable or cannot be supported, having regard to the evidence or to the fact that it involves a wrong decision on a question of law or that on any other grounds there was a miscarriage of justice ; or

(b) by confirming the finding or sentence ; or

20 (c) by referring the finding or sentence, or both, for confirmation to a higher confirming authority.

(2) Where a confirming authority is of the opinion that the facts of the case as considered by the court martial would have justified a finding of guilty by that court on other grounds, the confirming authority may, instead of withholding confirmation of the finding, substitute a finding of guilty on those other grounds and direct whether the punishment should be remitted in whole or in part or be commuted under the provisions of subsection (4) of this section.

30 (3) Where it appears to a confirming authority that a sentence of a court martial is invalid, the confirming authority may, instead of withholding confirmation of the sentence substitute therefor a proper sentence of any punishment which might have been awarded by the court, not exceeding or, in the opinion of the confirming authority, more severe than that awarded by the court martial.

35 (4) If the confirming authority confirms the sentence of a court martial the confirming authority may—

(a) remit in whole or in part any punishment awarded by the court martial, or

(b) commute any punishment so awarded for such other and lesser punishment or punishments as may be prescribed by this Act.

40 (5) A finding or sentence substituted by the confirming authority, or any sentence having effect after the confirming authority has remitted or commuted punishment, shall be treated for all purposes as a finding or sentence of the court duly confirmed.

45 (6) The confirmation of a finding or sentence shall not be deemed to be completed until the finding or sentence has been promulgated ; and in the event of any such substitution, remission or commutation as aforesaid, the finding or sentence shall be promulgated as it has effect after the substitution, remission or commutation.

50 (7) Where the confirming authority withholds confirmation under this section, notice thereof shall be promulgated, and it shall have effect as from the date of such promulgation.

Confirming  
authorities.

111.—(1) Subject to the provisions of this section, the following persons shall have power to confirm the finding and sentence of any court martial, that is to say—

(a) the officer who convened the court martial or any officer superior in command to that officer; or

(b) the successor of any such officer or superior officer, or any person for the time being exercising the functions of any such officer or superior officer; or

(c) any officer appointed by the board to act as confirming authority in default of any officer under paragraphs (a) and (b) of this subsection whether for the particular case or for a specified number of cases.

(2) The following persons shall not have power to confirm the finding or sentence of a court martial, that is to say—

(a) any officer who was a member of the court martial; or

(b) any officer who, as commanding officer of the accused, investigated the allegations against him or who is for the time being the commanding officer of the accused; or

(c) any officer who, as appropriate superior authority, investigated the allegations against the accused.

112. A sentence of death passed by a court martial shall not be carried into effect unless approved by the President.

Death  
sentence to  
be approved.

Review of  
findings and  
sentences of  
court  
martial.

113.—(1) The finding or sentence of a court martial as duly confirmed by a confirming authority may be reviewed,—

(a) by a reviewing authority consisting of—

(i) the board or (so far as the delegation extends) any officer to whom the powers of the board as reviewing authority or any of those powers may be delegated, or

(ii) any officer superior in rank to the confirming authority; or

(b) in proper case on appeal to or after leave to appeal has been granted by a court of competent jurisdiction;

and where a case is taken on appeal, the powers of a reviewing authority under paragraph (a) of this subsection, shall cease.

(2) If after confirmation of a finding or sentence a petition under section one hundred and eight of this Act is duly presented against the finding or the sentence, or both as the case may be, the finding or sentence shall, subject to the provisions of this section, be reviewed as soon as may be after the presentation of the petition and consideration of its contents.

(3) Where a finding or sentence is reviewed under this section the reviewing authority or the court, as the case may require, may—

(a) to the extent that the review is of a finding, quash the finding and, if the sentence relates only to the finding quashed, the sentence; or

(b) in any case, exercise the like powers of substituting findings, or valid sentences for invalid sentences, or of remitting or commuting punishment as are conferred on a confirming authority under this Act, and any substituted finding or sentence, or sentence having effect after the remission or commutation of punishment, shall be treated for all purposes as a sentence of the court martial duly confirmed.

(4) Any finding or sentence reviewed under this section shall be promulgated by a reviewing authority and shall have effect as from the date of such promulgation.

5       **114.**—(1) Sentences of imprisonment passed by courts martial may be reconsidered by the board and if on any such reconsideration it appears that the conduct of the offender since his conviction has been such as to justify remission of the sentence, whether in part or in whole, it may be remitted accordingly. Reconsideration of sentences of imprisonment.

10       (2) The power to reconsider a sentence may be exercised at any time after confirmation, and where, after review, a sentence remains effective it shall be reconsidered at intervals of six months ; but no delay in complying with this section at any such intervals shall invalidate the sentence.

#### *Review of Summary Findings and Awards*

15       **115.**—(1) Where a charge has been dealt with summarily and the charge is not dismissed, the board or any officer superior in command to the officer who dealt summarily with the charge, shall be the authority to review the finding or award at any time. Review of summary findings and awards.

20       (2) Where by reason of any mistake of law in the proceedings on the summary dealing with the charge or of anything occurring in those proceedings the reviewing authority is satisfied there had been a substantial injustice to the accused, that authority may quash the finding and any award on the finding.

25       (3) Where on a review under this section it appears to the said authority that a punishment awarded was invalid, or too severe, or (where the award included two or more punishments) that those punishments or some of them could not validly have been awarded in combination or are, taken together, too severe, the authority may vary the award by substituting such punishment or punishments as the authority may think proper, being a punishment or punishments which could have been included in the original award and not being in the opinion of the authority more severe than the punishment or punishments included in the original award.

#### *Findings of Insanity etc.*

35       **116.**—(1) Where, on the trial of a person by court martial, it appears to the court that the accused is by reason of insanity unfit to stand his trial, the court shall so find ; and if the finding is confirmed in accordance with the following provisions of this section the accused shall be kept in custody in such manner as may be provided by or under rules made under this Part of this Act until the directions of the President are known or until any earlier time at which the accused is fit to stand trial. Provisions where accused found insane.

40       (2) Where, on the trial of a person by court martial, it appears to the court that the evidence is such as, apart from any question of insanity, to support a finding that the accused was guilty of any offence, but that at  
45       the time of the act or omission constituting that offence the accused was by reason of mental disease or natural mental infirmity not criminally

responsible for the act or omission alleged as constituting the offence, the court shall find that the accused committed the act or omission but was insane at the said time, and thereupon the accused shall be kept in custody in such manner as may be provided by or under rules made under this Part of this Act until the directions of the President are known.

(3) In the case of any such finding as aforesaid the President may give orders for the safe custody of the accused during his pleasure in such place and in such manner as the President thinks fit.

(4) A finding under subsection (1) of this section shall not have effect unless and until the finding has been confirmed by the authority having power to confirm a finding of guilty by the court martial in question and the finding has been promulgated.

(5) Where the court or the confirming authority comes to or substitutes a finding under subsection (2) of this section, the confirming authority or, as the case may be, the reviewing authority shall not have power to substitute for that finding a finding of guilty; but save as aforesaid the provisions of this Act as to revision, confirmation and review (and in particular the provisions of this Act which confer power to substitute for any finding any other finding which would have been come to by the court martial in question) shall apply in relation to such findings as are provided for by subsection (2) of this section as those provisions apply in relation to findings of guilty.

(6) Unless otherwise provided in this Act or the context requires a different construction, references in this Act to a conviction or a finding of guilty in respect of any offence include references to findings under subsection (2) of this section in respect of the offence.

#### *Commencement, Suspension and Duration of Sentences*

Commence-  
ment of  
sentences.

117. Save as otherwise provided in this Act, a sentence of imprisonment shall begin to run from the beginning of the day on which the sentence was originally pronounced by the court martial trying the offender or, as the case may be, was originally awarded by the officer who tried the case summarily.

Duration of  
sentences of  
imprison-  
ment.

118.—(1) Where any person serving a sentence of imprisonment under this Act becomes unlawfully at large during the currency of the sentence, then, in calculating the period for which he is liable to be imprisoned in pursuance of the sentence, no account shall be taken of the time elapsing during the period beginning with the day on which he became at large and ending with the day on which, as a person having become unlawfully at large, he is taken into military, naval or air force custody or the custody of a civil authority or (not having been taken into such custody) returns to the place in which he was imprisoned before he became unlawfully at large:

Provided that if he satisfies such authority as may be specified in that behalf by or under Imprisonment Rules that during any time during the last-mentioned period he was—

(a) in the custody of a civil authority; or

(b) if and in so far as Imprisonment Rules so provide, in the custody of any military, naval or air force authority of any country or territory outside Nigeria as respects which arrangements have been made under section one hundred and twenty of this Act otherwise than on

account of an offence committed by him while unlawfully at large, the last mentioned time shall not be disregarded in calculating the period for which he is liable to be imprisoned or detained in pursuance of the sentence imposed under this Act.

5 (2) In subsection (1) of this section the expression "civil authority" means a civil authority (whether of the Federation or of any country or territory outside Nigeria) authorised by law to detain persons, and includes a police officer.

10 (3) Without prejudice to the provisions of subsection (1) of this section, where any person serving a sentence of imprisonment has in accordance with Imprisonment Rules been temporarily released on compassionate grounds, then, in calculating the period for which he is liable to be imprisoned in pursuance of the sentence, no account shall be taken of the time elapsing during the period beginning with the day  
15 after that on which he is released and ending with the day on which he is required to return to custody.

(4) A person who for any period is released as mentioned in subsection (3) of this section or is otherwise allowed, in pursuance of Imprisonment Rules, out of naval custody for any period or subject to any conditions shall, on failure to return at the expiration of the period or to comply with the conditions be treated for the purposes of subsection (1) of this section as being unlawfully at large.

(5) A person serving a sentence of imprisonment in civil custody who, after being temporarily released under the civil law of the country or territory in which he is serving his sentence, is at large at any time during the period for which he is liable to be detained in civil custody in pursuance of his sentence, shall be deemed to be unlawfully at large if the period for which he was temporarily released has expired or if an order recalling him has been made in pursuance of the civil law of  
30 such country or territory.

119. A person sentenced to death or imprisonment and committed or transferred to a civil prison in pursuance of rules made under this Part of this Act or of Imprisonment Rules, shall while in that prison be confined and otherwise dealt with in the same manner as a person  
35 confined therein under a sentence of a civil court.

Special provisions as to civil prisons.

120. The President may from time to time make arrangements with the authorities of any country or territory outside Nigeria whereby sentences of death passed by courts martial may in accordance with rules made under this Part of this Act be carried out in establishments  
40 under the control of those authorities and sentences of imprisonment or detention under this Act may, in accordance with Imprisonment Rules, be served wholly or partly in such establishments.

Serving of sentences outside Nigeria.

121.—(1) A person who is serving a sentence of imprisonment in Nigeria may, in so far as may be specified by or under Imprisonment Rules, be removed out of Nigeria to any place where the unit or any part thereof to which for the time being he belongs is serving or is  
45 under orders to serve, but not to any other place.

Country in which sentence of imprisonment is to be served.

(2) Subject to the following provisions of this section, a person sentenced under this Act by a court martial held out of Nigeria to imprisonment for more than twelve months shall as soon as practicable after the confirmation of the sentence is completed be removed to Nigeria.

50

(3) Where a person has been sentenced under this Act by a court martial held out of Nigeria to imprisonment for more than twelve months, the confirming authority or reviewing authority may, notwithstanding anything in subsection (2) of this section, direct that he shall not be required to be removed to Nigeria until he has served such part of his sentence, not exceeding two years, as may be specified in the direction; and in determining whether or not to exercise the powers conferred by this subsection, a confirming authority or reviewing authority shall have regard to any recommendation in that behalf made by the court martial.

(4) Any direction of a confirming authority under this section may at any time be revoked by the confirming authority or by a reviewing authority, or may be superseded by any direction of the confirming authority or a reviewing authority which either authority might have given under subsection (3) of this section; and any direction of a reviewing authority under this section may at any time be revoked by a reviewing authority or be superseded as aforesaid.

(5) Any direction given under this section, and the revocation of any such direction, shall be promulgated.

(6) In ascertaining at any time for the purposes of this section the nature or length of a sentence regard shall be had to any commutation or remission of the sentence previously directed.

Duties of persons in charge of prisons and others to receive prisoners.

122.—(1) It shall be the duty, in so far as rules made under this Part of this Act or Imprisonment Rules so provide, of the superintendent or other person in charge of a civil prison (not being a naval prison) to receive any person duly sent to that prison in pursuance of any such rules and to confine him until execution of the sentence is completed or the prisoner is discharged or delivered over in due course of law.

(2) Where a person is in naval custody in pursuance of a sentence of imprisonment, then on receipt of a written order in that behalf purporting to be signed by that person's commanding officer or the officer in command of any Nigerian naval ship or naval establishment it shall be the duty of any such superintendent or other person as aforesaid or the police officer in charge of a police station or of any person in charge of any other place in which prisoners may be lawfully confined to keep that person in custody for a period not exceeding seven days unless the said person is earlier discharged or delivered over in due course of law.

*Trial and Time Limit of Persons ceasing to be subject to Naval Law*

Trial, etc., of offences although offender no longer subject to naval law.

123.—(1) Subject to the provisions of section one hundred and twenty-four of this Act, where an offence under this Act triable by court martial has been committed, or is reasonably suspected of having been committed, by any person while subject to this Act, then in relation to that offence he shall be treated, for the purposes of the provisions of this Act relating to arrest, keeping in custody, investigation of charge, trial and punishment by court martial (including confirmation, review and reconsideration) and execution of sentences as continuing subject to this Act notwithstanding his ceasing at any time to be subject thereto.

(2) Where a person in custody by virtue of this section whether before, during or after trial commits, or is reasonably suspected of having committed, an offence which if he were subject to naval law under this Act would be an offence under this Act triable by court martial, then in relation to that offence or suspected offence he shall be treated, for the purposes of the provisions of this Act mentioned in subsection (1) of this section and the provisions thereof as to the summary dealing with charges, as having been subject to this Act when the offence was committed or is suspected of having been committed and as continuing subject thereto thereafter.

(3) Where by virtue of either subsection (1) or subsection (2) of this section a person is treated as being at any time subject to this Act for the purpose of any provision of this Act, that provision shall apply to him—

(a) if he holds any naval rank, as to a person having that rank ;

(b) otherwise as to a person having rank which he had when last actually subject to this Act :

Provided that as respects any time after he has been sentenced for the offence in question and the sentence has been confirmed the said provision shall apply to him (in any case) as to a rating.

(4) Where apart from this subsection any provision of this Act would under subsection (3) of this section apply to a person in relation to different offences, as to a person having two or more different ranks in the navy, it shall apply to him as to a person having the lower or lowest of those ranks, as the case may be.

124.—(1) No person shall be tried by court martial for any offence (other than mutiny, failure to suppress mutiny, or the offence of desertion) unless the trial is begun within three years after the commission of the offence, regard not being had to any period of time during which that person was a prisoner of war or was illegally absent :

Limitation of time for trial of offences under this Act.

Provided that—

(a) in the case of an offence against section eighty-two of this Act where proceedings for the corresponding civil offences are, by virtue of any written law, to be brought within the limited time, that limit of time shall apply to the trial of the offence under the said section eighty-two in substitution for the foregoing provisions of this subsection ;

(b) a person may, subject to any time limit prescribed by any written law mentioned in paragraph (a) and to the consent of the Attorney-General of the Federation, be tried by court martial for a civil offence committed outside Nigeria notwithstanding that it was committed more than three years before the beginning of the trial.

(2) A person shall not be triable by virtue of subsection (1) of section one hundred and twenty-three of this Act unless his trial is begun within three months after he ceases to be subject to this Act or the trial is for a civil offence committed outside Nigeria and the Attorney-General of the Federation consents to the trial ; but this subsection shall not apply to the offences of mutiny, failure to suppress mutiny and desertion under this Act.

*Relations between Naval and Civil Courts and Finality of Trials*Powers of  
civil courts.

125.—(1) Subject to the provisions of section one hundred and forty-seven, nothing in this Act shall restrict the offences for which a person may be tried by any civil court, or the jurisdiction of any civil court to try a person subject to this Act, for any offence.

(2) Where a person is tried by a civil court for any offence, and he has in pursuance of this Act been punished for any act or omission constituting (whether wholly or in part) that offence on summary trial under section eighty-eight or eighty-nine of this Act the civil court shall, in awarding punishment, have regard to his punishment in pursuance of this Act.

Offences  
already dis-  
posed of not  
to be retried.

126.—(1) Where a person subject to this Act—

(a) has been tried for an offence by a competent civil court or a court martial under service law ; or

(b) has been charged with an offence under service law, and has had the charge dismissed, or has been found guilty on the charge on summary trial under section eighty-eight or eighty-nine of this Act ; or

(c) has had an offence condoned by his commanding officer, he shall not be liable in respect of that offence to be tried by court martial or to have the case dealt with summarily under section eighty-eight or eighty-nine of this Act.

(2) For the purposes of this section—

(a) a person shall not be deemed to have been tried by a court martial if confirmation is withheld of a finding by the court martial that he is guilty of the offence ;

(b) a case shall be deemed to have been dealt with summarily notwithstanding that the finding of the officer who summarily tried the charge has been quashed or varied on review thereof ;

(c) an offence shall be deemed to have been condoned by the commanding officer of a person alleged to have committed the offence if, and only if, that officer or any officer authorized by him to act in relation to the alleged offence has with knowledge of all relevant circumstances informed him that he will not be charged therewith ;

(d) a person ordered under subsection (2) of section seventy of this Act, or the corresponding provision of any service law, to be imprisoned for an offence against that section or provision shall be deemed to have been tried by court martial for the offence.

(3) Where confirmation of a finding of guilty of an offence is withheld the accused shall not be tried again by court martial for that offence unless the order convening the later court martial is issued not later than twenty-eight days after the promulgation of the decision to withhold confirmation.

(4) Save as provided in the foregoing provisions of this section proceedings for an offence against this Act (whether summarily or before a court martial) shall not be barred on the grounds of condonation.

*Inquiries*Boards of  
inquiry.

127.—(1) Subject to and in accordance with the provisions of rules made under this Part of this Act (in this Act referred to as "Boards of Inquiry Rules"), the board or any naval, military or air force officer

commanding a body of naval personnel may convene a board of inquiry to investigate and report on the facts relating to any matter which may be referred to such board of inquiry by the board or any such officer as aforesaid ; and a board of inquiry shall, if directed so to do, express their opinion on any question arising out of any matter referred to them.

(2) A board of inquiry shall consist of such number of persons as may be provided for by the Boards of Inquiry Rules, who shall be persons subject to service law, and the president of a board of inquiry shall be an officer not below the rank of sub-lieutenant or corresponding rank.

(3) Evidence given before a board of inquiry shall not be admissible against any person in proceedings before a court martial or at a summary trial other than proceedings for an offence against section seventy-one or for an offence against section eighty-two when the corresponding offence is perjury.

128.—(1) Where a board of inquiry inquiring into the absence of an officer or rating reports that he has been absent without leave or other sufficient cause for a period specified in the report, not being less than twenty-one clear days, a record of the report shall in accordance with the Board of Inquiry Rules be entered in the service books.

Inquiries into absence.

(2) A record entered in pursuance of subsection (1) of this section shall, unless the absentee subsequently surrenders or is arrested, or the report of the board of inquiry is annulled by the board or a subsequent board of inquiry, have the like effect as a conviction by a court martial for desertion.

#### *Miscellaneous Provisions*

129.—(1) The following provisions of this section shall have effect where a person has been convicted by court martial of unlawfully obtaining any property, whether by stealing it, receiving it or retaining it knowing or having reason to believe it to have been stolen, fraudulently misapplying it or otherwise.

Restitution or compensation for theft, etc.

(2) If any of the property unlawfully obtained has been found in the possession of the offender, it may be ordered to be delivered or paid to the person appearing to be the owner thereof.

(3) If there has been found in the possession of the offender any property (other than money) appearing to have been obtained by him by the conversion or exchange of any of the property unlawfully obtained, the property may be ordered to be delivered to the person appearing to be the owner of the property unlawfully obtained.

(4) Where money is found in the possession of the offender, then whether or not it appears to have been obtained as aforesaid an order may be made that there shall be paid out of that money to the person appearing to be the owner of the property unlawfully obtained such sum as may be specified in the order as or towards compensation for the loss caused to the said person by the offence, in so far as not otherwise made good under this Act or by the recovery of the property unlawfully obtained.

(5) Where any of the property unlawfully obtained has been sold or given in pawn to some other person who did not then know it to have been unlawfully obtained, an order may be made that, subject to the restitution to the owner thereof of the property sold or given as aforesaid,

there shall be paid to the said other person, out of any money found in the possession of the offender (whether or not the money appears to be proceeds of the sale or giving in pawn), such sum as may be specified in the order as or towards compensation for the loss caused to him in consequence of the sale or giving in pawn.

5

(6) Where any of the property unlawfully obtained has been given in exchange to some other person who did not then know it to have been unlawfully obtained, an order may be made that, subject to the restitution to the owner thereof of the property given as aforesaid, there shall be restored to the said other person the property taken in exchange for the property unlawfully obtained.

10

(7) An order under this section may be made by the court martial by whom the offender is convicted, or by the confirming authority, or any reviewing authority; but an order under this section made by a court martial shall not have effect until confirmed by the confirming authority and the provisions of this Part of this Act as to the confirmation and review of the proceedings of courts martial shall apply to an order under this section as they apply to a sentence.

15

(8) The operation of any order under this section shall be suspended—

20

(a) in any case, until the expiration of the period prescribed under Part V as the period within which an application for leave to appeal to the Supreme Court against the conviction must be lodged; and

(b) if such an application is duly lodged, until either the application is finally refused or is withdrawn or the appeal is determined or abandoned;

25

and where the operation of such an order as aforesaid is suspended under this section—

(i) it shall not take effect if the conviction is quashed on appeal;

(ii) the Supreme Court may by order annul or vary the order although the conviction is not quashed;

30

(iii) such steps shall be taken for the safe custody, during the period during which the operation of the order is suspended, of the property ordered to be restored or handed over or the money to which the order relates as may be provided by rules of court made under Part V of this Act.

35

(9) Notwithstanding anything in subsection (8) of this section, an order under this section shall not, so far as it relates to the delivery of property to the person appearing to be the owner thereof, be suspended if the court or authority making the order directs to the contrary in any case in which, in the opinion of the court or authority, the title to the property is not in dispute.

40

(10) An order under this section shall not bar the right of any person, other than the offender or a person claiming through him to recover any property delivered or paid in pursuance of such an order from the person to whom it is delivered or paid.

45

(11) In this section, "appearing" in relation to an order, means appearing to the court martial, or to the confirming authority, or reviewing authority making the order, as the case may require.

130. Any finding, sentence, determination or other thing required by this Act to be promulgated shall be promulgated either by being communicated to the accused or as the confirming or reviewing authority, as the case may be, may direct.

Promulgation of findings etc.

5 131.—(1) The record of the proceedings of a court martial shall be kept in the custody of the commander for not less than the prescribed period, being a period sufficient to ensure that the rights conferred by subsections (2) and (3) of this section shall be capable of being exercised.

Custody of proceeding of court martial and right to copies.

10 (2) Subject to the provisions of this section, any person tried by a court martial shall be entitled to obtain from the commander on demand at any time within the relevant period and on payment therefore at such rate as may be prescribed a copy of the record of the proceedings of the court.

15 (3) Where a person tried by court martial dies within the relevant period, his personal representatives or any person who in the opinion of the commander ought to be treated for the purposes of this subsection as his personal representative shall, subject to the provisions of this section, be entitled to obtain from the commander on demand at any time within the period of twelve months from the death and payment therefor at the prescribed rate a copy of the record of the proceedings of the court.

20 (4) If, on an application in pursuance of either subsection (2) or subsection (3) of this section for a copy of the record of any proceedings, the Minister certifies that it is requisite for reasons of security that the proceedings or any part thereof should not be disclosed, the applicant shall not be entitled to a copy of the proceedings or part to which the certificate relates.

25 (5) In this section the expression "the relevant period" in relation to any person tried by court martial, means the period of five years beginning with the date of his acquittal, or, where he was convicted, of the promulgation of the findings and sentence or, where a finding of guilty was not confirmed, of the promulgation of the withholding of confirmation :

30 Provided that where the proceedings relate to two or more charges and the person tried was acquitted on one or more of the charges and convicted on another or others, the relevant period shall be the period of five years beginning with the date of the promulgation of the findings of guilty and the sentence thereon or of the withholding of confirmation of that finding, or those findings.

35 (6) Any reference in this section to the record of the proceedings of a court martial includes a reference to the record of the proceedings with respect to the confirmation or revision of the findings and sentence of the court martial.

40 132. No action shall lie in respect of anything done by any person in pursuance of a sentence of imprisonment under this Act if the doing thereof would have been lawful but for a defect in any warrant or other instrument made for the purposes of that sentence.

Indemnity for prison officers, etc.

#### *Redress of Complaints*

45 133.—(1) If any officer or rating of the navy or the reserve thinks he has suffered any personal oppression, injustice or other ill-treatment from a superior officer or authority, he may make a complaint in accordance with such procedure as may be prescribed ; and if the complainant is

Complaints by officers and ratings.

not satisfied with the decision of any authority to whom his complaint is made or that authority neglects or refuses, when requested to do so, to forward the complaint to the next superior officer or authority, the complainant shall be entitled to make his complaint direct to the next superior officer or authority, and so on up to the navy board whose decision shall be final. 5

(2) It shall be the duty of any superior officer or authority to whom a complaint is made under this section to have the complaint investigated as soon as practicable and to take any steps for redressing the matter complained about which appear to that officer or authority to be necessary. 10

(3) No officer or rating shall be penalized for having made a complaint in accordance with this section.

Power to refer complaints by officer to the President.

134. In the case of a complaint by an officer the board may report the complaint through the Minister for the directions (if any) of the President. 15

(2) If a rating thinks himself wronged in any matter by his commanding officer, either by reason of redress not being given to his satisfaction on a complaint under subsection (1) of this section or for any other reason, he may make a complaint with respect thereto to any military, naval or air force officer under whom the complainant is for the time being serving, being an officer not below the rank of commodore or corresponding rank. 20

(3) It shall be the duty of a commanding officer or other officer to have any complaint received by him under this section investigated and to take any steps for redressing the matter complained of which appear to him to be necessary. 25

#### *Rules of Procedure, etc.*

Rules of procedure and other rules.

135.—(1) The President may make rules of procedure generally for the purposes of this Part of this Act, and without prejudice to the generality of the foregoing, rules may be made— 30

(a) for the convening, constitution and conduct of courts martial ;

(b) with respect to the execution of sentences of death under this Act, including the manner and place where such executions are to be carried out and the custody, treatment and removal of persons under sentence of death ; 35

(c) for the execution of sentences of imprisonment including the prisons, civil or otherwise, in which they are to be served, the classification, treatment, employment, discipline, control, removal and temporary release on compassionate grounds of persons serving such sentences and the appointment, powers and duties of inspectors, visitors, governors and other members of the staff and officers in charge of persons serving sentences of imprisonment ; 40

(d) with respect to field punishment ;

(e) for the convening, constitution and procedure of boards of inquiry, the rules of evidence to be observed and the taking of evidence by such boards, including the administration of oaths and affirmations to witnesses and the making of reports by such boards ; 45

(f) in respect of matters for which rules may be made under the foregoing provisions of this Part of this Act ;

(g) for such incidental and supplementary matters as appear requisite for the purpose of the foregoing.

- 5 (2) Notwithstanding the repeal of any Act by section two hundred and thirteen of this Act, all regulations, rules or instructions relating to discipline and trial of offences in operation immediately before the repeal of the Royal Nigerian Navy Act, 1960 shall continue in force and may be used with such adaptations, modifications and exceptions as are  
10 necessary to give effect thereto under this Act.

1960 No. 9

*Interpretation of this Part*

- 136.—(1) In this Part—

“air-force prison” means separate premises designated by the commander of the Nigeria Air Force for persons serving air force sentences of imprisonment ;

“civil prison” means a prison in Nigeria in which a person sentenced by a civil court to imprisonment can for the time being be confined ;  
“convening officer”, in relation to a court martial, means the officer convening that court martial and includes his successor or any person for the time being exercising his or his successor's functions ;

“military prison” means separate premises designated by the commander of the Nigerian Army for persons serving military sentences of imprisonment ;

“naval prison” means premises or vessels or parts of premises or vessels designated by the commander for persons serving naval sentences of imprisonment ;

“prescribed” means prescribed by Rules of Procedure ;

“prison” includes a civil prison and any military, naval or air force prison.

- 30 (2) Reference in this Part of this Act to a sentence of imprisonment are references to a sentence of imprisonment passed by a court martial or awarded summarily under section eighty-eight or section eighty-nine of this Act.

- 35 (3) References in this Part of this Act to detention or to sentences of detention shall include references to detention passed by a court martial or to any such sentence by the offender's commanding officer.

- 40 (4) Where persons subject to this Act are appointed or drafted to a naval ship or establishment for duty those persons shall be treated for the purposes of this Act as belonging to the ship or establishment to which they are appointed or drafted.

(5) References in this Part of this Act to chief petty officers do not include references to acting chief petty officers.

(6) References in this Part of this Act to petty officers include references to acting petty officers and to acting chief petty officers.

45 PART V—APPEALS FROM COURTS MARTIAL

137. Subject to the following provisions of this Part of this Act, an appeal shall lie from decisions of a court martial to the Supreme Court with the leave of the Supreme Court ; and shall lie as of right without such leave, from any decision of a court martial involving a  
50 sentence of death.

Interpretation of Part IV.

Right of appeal.

Procedure  
for applying  
for leave to  
appeal or  
lodging  
appeal.

138.—(1) Leave to appeal against the finding of a court martial may be granted by the Supreme Court on application made to it by the appellant in the prescribed form setting out the grounds on which leave to appeal is sought and such other particulars (if any) as may be prescribed, and lodged with the registrar of that court or if rules of court otherwise allow, lodged with any other person. 5

(2) The application shall, in the case of any finding involving a sentence of death, be lodged within ten days of the date of promulgation of the finding, and in any other case within forty days thereof.

(3) The Supreme Court may extend the period within which application for leave to appeal is made in respect of any finding other than one involving a sentence of death, and whether or not the said period of forty days has expired. 10

(4) Rules of court may provide that, in such circumstances as may be specified therein, any application for leave to appeal or the appeal itself may, when lodged with such person other than the registrar as may be specified in such rules, be treated for the purposes of this section as having been duly lodged with the registrar. 15

(5) In considering whether or not to grant leave to appeal, the Supreme Court shall have regard to any opinion expressed by the judge advocate, if any, who acted at the court martial on the merits of the case as one for appeal. 20

(6) Where the Supreme Court dismisses an application for leave to appeal it may, if it considers the application to have been frivolous or vexatious, order that any sentence passed upon the applicant in the proceedings from which it was sought to bring the appeal shall begin to run from the day on which the Court dismisses the application. 25

Determina-  
tion of  
appeals in  
ordinary  
cases.

139.—(1) Subject to the provisions of this and the next succeeding section, the Supreme Court shall allow an appeal against a conviction if it thinks that the finding of the court martial is unreasonable or cannot be supported having regard to the evidence or that it involves a wrong decision on a question of law, or that there was a miscarriage of justice; and in any other case the Supreme Court shall dismiss the appeal. 30

(2) Notwithstanding the provisions of the foregoing subsection, the Supreme Court may dismiss an appeal if of the opinion that the point raised in the appeal might be decided in favour of the appellant, but no substantial miscarriage of justice has occurred. 35

(3) If the Supreme Court allows an appeal against a conviction under this Part of this Act it shall quash the conviction.

(4) On an appeal under this Part of this Act against sentence the Supreme Court shall, if it is of opinion that a different sentence should have been passed, quash the sentence passed by the court martial and pass such other sentence (whether more or less severe) in substitution therefore as it thinks ought to have been passed, being a sentence which under section eighty-three or section eighty-four of this Act, could lawfully have been passed for the offence of which the appellant was convicted or, if it is not of opinion that a different sentence should have been passed, it shall dismiss the appeal. 40 45

(5) The term of any sentence imposed by the Supreme Court under subsection (4) of this section shall, unless that court otherwise directs, begin to run from the time from which it would have begun to run if it had been imposed in the proceedings from which the appeal was brought, and any such sentence shall be deemed for the purposes of this Act to be a sentence passed by the court martial and duly confirmed.

140.—(1) If it appears to the Supreme Court that an appellant, though not properly convicted on some charge preferred against him before the court martial by which he was tried, was properly convicted on some other charge so preferred, then, if the sentence passed by the court martial on the appellant was not one which could lawfully be passed by the court martial for the offence of which he was convicted on the other charge, the Supreme Court shall pass on the appellant, in substitution for the sentence passed on him by the court martial, such sentence as it thinks proper, being a sentence which, under section eighty-three or section eighty-four of this Act, could lawfully have been passed in respect of the charge on which the appellant was properly convicted, but not being a sentence of greater severity.

Powers of the Supreme Court in special cases.

(2) Where an appellant has been convicted of an offence and the court martial by which he was tried could lawfully have found him guilty of some other offence, and it appears to the Supreme Court that the court martial must have been satisfied of facts which proved him guilty of that other offence, the Supreme Court may, instead of allowing or dismissing the appeal, substitute for the finding of the court martial a finding of guilty of the other offence and pass on the appellant, in substitution for the sentence passed on him by the court martial, such sentence as it thinks proper, being a sentence which, under section eighty-three or section eighty-four of this Act, could lawfully have been passed for that other offence but not being a sentence of greater severity.

(3) Where—

(a) an appellant has been convicted of an offence committed under circumstances involving the higher of two degrees of punishment, and it appears to the Supreme Court that the court martial by which he was tried ought to have found him guilty of the offence as being committed under circumstances involving the lower degree of punishment ; or

(b) an appellant has been convicted of an offence and it appears to the Supreme Court that the court martial by which he was tried ought to have found him guilty of the offence subject to exception or variations,

the Supreme Court may, instead of allowing or dismissing the appeal, substitute for the finding of the court martial a finding of guilty of the offence as being committed under circumstances involving the lower degree of punishment or, as the case may be, guilty of the offence subject to exceptions or variations and pass on the appellant, in substitution for the sentence passed on him by the court martial, such sentence as it thinks proper, being a sentence which, under section eighty-three or section eighty-four of this Act, could lawfully have been passed for the offence specified or involved in the substituted finding, but not being a sentence of greater severity.

(4) If, on appeal, it appears to the Supreme Court that, although the appellant committed the act or omission charged against him, he was insane at the time the act was done, or the omission made, so as not to be

responsible according to law for his actions, the Supreme Court may quash the sentence passed at the trial and order the appellant to be kept in custody, under the provisions of section one hundred and sixteen of this Act, in like manner as on a special finding of insanity by the court martial by which the appellant was convicted. 5

(5) The term of any sentence imposed by the Supreme Court under any of the foregoing provisions of this section shall, unless the Supreme Court otherwise directs, begin to run from the time which it would have begun to run if it has been passed in the proceedings from which the appeal was brought, and any such sentence shall be deemed for the purposes of this Act to be a sentence imposed by the court martial and duly confirmed. 10

Appeals to be final.

141. The determination by the Supreme Court of any appeal or other matter which it has power to determine under the provisions of this Part of this Act shall be final. 15

Supplementary powers of the Supreme Court.

142. For the purposes of this Part of this Act the Supreme Court may, if it thinks it necessary or expedient in the interests of justice, appoint any person with special expert knowledge to act as assessor in any case where it appears to the Supreme Court that such special knowledge is required for the proper determination by it of the case. 20

Proceedings to be heard in absence of appellants.

143. An appellant shall not be entitled to be present at the hearing of an appeal to the Supreme Court under this Part of this Act or at any proceedings preliminary or incidental to such an appeal except where rules of court provide that he shall have the right to be present or the Supreme Court gives him leave to be present, and accordingly any power of the Supreme Court under this Part of this Act to pass a sentence may be exercised notwithstanding the absence of the appellant. 25

Defence of appeals.

144. It shall be the duty of the board on an appeal against a decision of a court martial to undertake the defence of the appeal.

Right of appellant to present his case in writing.

145. An appellant may, if he so desires, instead of presenting his case orally, present it in writing in the prescribed form. 30

Suspension of death sentences.

146. Where a conviction by court martial involves sentence of death, the sentence shall not in any case be executed until the expiration of the period within which an appeal to the Supreme Court against the conviction may be lodged; and if such an appeal is lodged, the sentence shall not be executed pending the determination or dismissal of the appeal, or as the case may be, the appeal is abandoned. 35

Persons not to be tried again where conviction quashed.

147. Where the conviction of a person by a court martial for an offence has been quashed under this Part of this Act, he shall not be liable to be tried again for that offence by a court martial or by any other court. 40

Removal of prisoners for purposes of proceedings.

148. Imprisonment Rules may provide in what manner an appellant, when in custody, is to be taken to, kept in custody at, and brought back from any place at which he is entitled to be present for the purposes of this Part of this Act or any place to which the Supreme Court or a Justice thereof may order him to be taken for the purpose of any proceedings of the Supreme Court. 45

149. In the case of every appeal, or application for leave to appeal, under this Part of this Act to the Supreme Court against a decision of a court martial, it shall be the duty of the commander to furnish to the registrar of the Supreme Court, in accordance with rules of court, the proceedings of the court martial (including any proceedings with respect to the revision of the findings or sentence of the court martial in pursuance of subsection (1) of section one hundred and thirteen of this Act with respect to the confirmation of the finding and sentence of the court martial).

Furnishing, on appeal, of documents relating to trial.

150.—(1) The registrar of the Supreme Court shall furnish the necessary forms and instructions relating to appeals or applications for leave to appeal under this Part of this Act to any person requiring them, to persons in charge of places where persons sentenced by court martial may lawfully be confined for the purpose of serving their sentences, and to such other persons as the registrar thinks fit; and every person in charge of such a place as aforesaid shall cause the forms and instructions to be placed at the disposal of persons confined in that place who desire to lodge an appeal or make application for leave to appeal under this Part of this Act.

Duties of registrar of the Supreme Court in respect of appeals, etc.

(2) The registrar of the Supreme Court shall forthwith upon receipt of an appeal or application for leave to appeal under this Part of this Act, obtain and lay before the Supreme Court in proper form all documents, exhibits and other things relating to the proceedings in the court martial by which the appellant or applicant was tried, which appear necessary for the proper determination of the appeal or of the application, as the case may be.

151.—(1) The Chief Justice of Nigeria may make rules of court for regulating the procedure and practice to be followed in the Supreme Court for the purposes of this Part of this Act.

Rules of court.

(2) Rules of court made for the purposes of any provision of this Part of this Act may make different provision in relation to different classes of cases and may provide for any incidental or supplementary matters for which it appears to the Supreme Court to be necessary or expedient for the purposes of that provision to provide.

(3) Reference in this Part of this Act to "prescribed" shall be to any matter or thing prescribed by rules of court.

152. Nothing in this Part of this Act shall affect the exercise by reviewing authorities of the power conferred upon them by section one hundred and thirteen of this Act in respect of a decision of a court martial so far as regards the exercise by them of those powers at any time before the lodging with the registrar of the Supreme Court of an appeal or an application for leave to appeal, as the case may be, against the decision; and nothing in the Part of this Act shall affect the exercise by the President of the prerogative of mercy under the Constitution of the Federation.

Saving of reviewing authorities' powers.

153. Upon the hearing of any appeal from a court martial the Supreme Court shall consist of at least three Justices.

Composition of court.

Exercise of certain powers of the Supreme Court by a Justice.

154. Notwithstanding the provisions of section one hundred and fifty-three of this Act, any Justice of the Supreme Court may—

(a) give leave to appeal, or

(b) extend the time limit within which an application for leave to appeal otherwise than in the case of sentence of death may properly be lodged under section one hundred and thirty-eight of this Act; or

(c) allow an appellant to be present at any proceedings under this part of this Act,

but nothing in this section shall be construed to preclude the hearing and determination of any such application if a Justice refuses the application, and accordingly the appellant or applicant, as the case may be, shall be entitled, notwithstanding such refusal, to have the application dealt with before the Supreme Court sitting with not less than three Justices under the provisions of said section one hundred and fifty-three.

General provisions as to procedure. No. 12 of 1960.

155. Subject to the provisions of this Part of this Act and to any rules of court, the provisions of the Supreme Court Act, 1960, relating to the hearing of appeals from subordinate courts shall apply to the hearing and determination of an appeal under this Part of this Act.

#### PART VI.—PAY, FORFEITURES AND DEDUCTIONS

Regulations as to pay.

156. The President shall make regulations governing the pay, allowances and other emoluments of the officers and ratings of the navy (in this Act referred to as "pay regulations") and other matters pertaining thereto and in particular governing the following provisions of this Part of this Act.

Forfeitures and deductions: general provisions.

157.—(1) No forfeiture of the pay of an officer or rating shall be imposed unless authorised by service law or some other written law and no deduction from such pay shall be made unless so authorised or authorised by pay regulations.

(2) Pay regulations shall not authorise the making of any penal deduction, that is to say, a deduction to be made by reason of the commission of any offence or other wrongful act or in consequence of any negligence.

(3) The foregoing provisions of this section shall not prevent the making of pay regulations providing for the imposition of any forfeiture authorised by this Act or the making of any deduction so authorised, or for the time at which and manner in which sums may be deducted from pay to give effect to authorised deduction or the manner in which amounts may be so deducted in order to recover any fine imposed in pursuance of this Act, or as to the appropriation of any such sum or amount when deducted, or of providing for the determination of questions relating to forfeitures or deductions.

(4) Notwithstanding any deduction from the pay of an officer or rating, he shall (subject to any forfeiture) remain in receipt of pay at not less than such minimum rate as may be prescribed in pay regulations.

(5) Notwithstanding that forfeiture of pay of an officer or rating for any period has been ordered in pursuance of this Act, he shall remain in receipt of pay at such a minimum rate as aforesaid, but the amount received for that period may be recovered from him by deduction from pay.

(6) Any amount authorised to be deducted from the pay of an officer or rating may be deducted from any balance (whether or not representing pay) which may be due to him as an officer or rating and references in this Act to the making of deduction from pay shall be construed accordingly; and the whole or any part of any sum forfeited from an offender's pay may be recovered by deduction from any such balance.

158.—(1) The pay of an officer or rating may be forfeited—

(a) for any day of absence in such circumstances as to constitute an offence under section forty-nine or fifty of this Act, or, if the commander so directs, of other absence without leave;

(b) for any day of imprisonment, detention or cells awarded under service law by a court martial or upon summary trial, or of imprisonment or detention of any description to which he is liable in consequence of an order or sentence of a civil court;

(c) where he is found guilty (whether by court martial or upon summary trial) of an offence under service law, for any day (whether before or after he is found guilty) on which he is in hospital on account of sickness or injury certified by the proper medical officer to have been occasioned by the offence.

(2) The pay of an officer or rating may be forfeited for any day of absence by reason of his being made a prisoner of war if the commander is satisfied—

(a) that he was made a prisoner of war through disobedience of orders or wilful neglect of his duty; or

(b) that having been made a prisoner of war he failed to take any reasonable steps available to him to rejoin the service of Nigeria; or

(c) that having been made a prisoner of war he served with or aided the enemy in the prosecution of hostilities or measures calculated to influence morale or in any other manner whatsoever not authorised by international usage,

but, save as aforesaid, nothing in paragraph (a) of subsection (1) of this section shall apply to absence by reason of having been made a prisoner of war.

(3) Pay regulations may make provision as to the computation of time for the purposes of this section and in particular as to the counting or disregarding of parts of days.

159. Where an officer or rating charged with an offence before a civil court (whether within or without Nigeria) is sentenced or ordered by the court to pay any fine, penalty, damages, compensation or costs, and the whole or part thereof is met by a payment made by or on behalf of any naval authority, the amount of the payment may be deducted from his pay.

160.—(1) Without prejudice to the provisions of this Act as to the imposition of stoppages as a punishment, the following provisions shall have effect where, after such investigation as may be prescribed by pay regulations it appears to the board, the commander or an officer authorised in pay regulations that any loss of, or damage to, public or service property has been occasioned by any wrongful act or negligence of an officer or rating (in this Act referred to as "the person responsible").

Forfeiture of pay for absence from duty.

Deductions for payment of civil penalties.

Compensation for loss occasioned by wrongful act or negligence.

(2) The board, the commander or authorised officer, as the case may be, may order the person responsible to pay as or towards compensation for the loss or damage, such sum as may be specified in the order, and such sum, in so far as not otherwise paid by the person responsible, may be deducted from his pay. 5

(3) No order shall be made under the provisions of subsection (2) of this section if, in proceedings before a court martial under service law, or upon summary trial, the person responsible—

(a) has been acquitted in circumstances involving a finding that he was not guilty of the wrongful act or negligence in question ; or 10

(b) has been awarded stoppages in respect of the same loss or damage, but save as aforesaid, the fact that such proceedings have been brought in respect of the wrongful act or negligence in question shall not prevent the making of an order or deductions under subsection (2) of this section. 15

Deductions  
for barrack  
damage.

161.—(1) Where damage occurs to any premises in which one or more units or parts of such units are quartered or billeted, or any fixtures, furniture or effects in or belonging to such premises are damaged or lost, and it appears on investigation in accordance with the provisions of pay regulations that the damage or loss was occasioned by the wrongful act or negligence of persons belonging to any of the units or parts of units in occupation of such premises, but that the said persons cannot be identified, any person belonging to any of such units or parts of units may be required to contribute towards compensation for the damage or loss such amount as may in accordance with pay regulations be determined to be just, and the amount may be deducted from his pay. 20 25

(2) The provisions of subsection (1) of this section shall extend to ships, trains, motor vehicles and aircraft in which units or parts of units are being transported and references to premises, quartering and occupation shall be construed accordingly. 30

Remission of  
forfeitures  
and deduc-  
tions.

162. Any forfeiture or deduction imposed under the provisions of sections one hundred and fifty-eight, one hundred and fifty-nine, one hundred and sixty or one hundred and sixty-one of this Act or under pay regulations may be remitted by the board or in such manner and by such authority as may be provided by such regulations. 35

## PART VII—GENERAL PROVISIONS

### *Exemptions for Members of Navy*

Exemption  
from tolls,  
etc.

163.—(1) Duties or tolls for embarking from or disembarking on any pier, wharf, quay or landing place in Nigeria, or for passing over any road, ferry or bridge in Nigeria, shall not be payable in respect of— 40

(a) a member of the navy on duty ;

(b) vehicles in naval service, being vehicles belonging to the Federation or any Region thereof or other vehicles driven by persons (whether a member of the navy or not) in the public service of the Federation or any Region thereof ; 45

(c) goods carried in such vehicles.

(2) Harbour dues or other charges for entering, leaving, and anchoring or mooring in, any harbour or port in Nigeria, shall not be payable in respect of any naval ship or vessel belonging to the Federation.

(3) In subsection (1) of this section the expression "in naval service" means employed under proper naval authority for the purposes of any ship, vessel or establishment of the navy.

164. No judgment, decree or order given or made against a member of the navy by any court in Nigeria shall be enforced by the levying of execution on any property of the person against whom it is given or made, being public property, used by him for naval purposes.

Exemption from taking in execution of property used for naval purposes.

165. The officers and ratings of the navy and the reserve shall, for purposes of the navy, be exempt from the provisions of any enactment relating to the storage, possession or transmission of firearms, explosives, gunpowder or munitions of war to the same extent and in the same manner as members of any other of the armed forces of Nigeria are so exempt.

Exemptions as to arms and explosives.

#### *Deserters and Absentees without Leave*

166.—(1) Any police officer may arrest without a warrant any person whom he has reasonable cause to suspect of being an officer or rating who has deserted or is absent without leave; and where no police officer is available, any other person may in like circumstances arrest without a warrant any such person.

Arrest of deserters and absentees without leave.

(3) If any person authorised to issue a warrant for the arrest of a person charged for a criminal offence is satisfied by evidence on oath that there is, or there is reasonably suspected of being, within the jurisdiction an officer or rating who has deserted or is absent without leave, or is reasonably suspected of having deserted or of being absent without leave, he may issue a warrant for the arrest of the officer or rating.

(4) Any person in custody in pursuance of this section shall as soon as practicable be brought before a magistrate's court.

(5) Notwithstanding the provisions of any other Act or rule of law, a person appearing before a magistrate's court under this section, shall not be admitted to bail.

167.—(1) Where a person who is brought before a magistrate's court is alleged to be an officer or rating of the navy who has deserted or is absent without leave, the following provisions shall have effect.

Proceeding before a court where persons suspected illegal absence.

(2) If the person so before such court admits that he is illegally absent from the navy and the court is satisfied of the truth of the admission, then, unless he is in custody for some other cause, the court shall, notwithstanding that he is in custody for some other cause, the court may, forthwith either cause him to be delivered into naval custody in such manner as the court may think fit or commit him to some prison, police station or other place provided for the confinement of persons in custody, to be kept there for such reasonable time as the court may specify (not exceeding such time as appears to the court reasonably

necessary for the purpose of enabling him to be delivered into naval custody) or until sooner delivered into such custody. Any time specified by the court may be extended by the court from time to time if it appears to the court reasonably necessary so to do for the purpose aforesaid.

(3) If such person does not admit that he is illegally absent as aforesaid, or the court is not satisfied of the truth of the admission, the court shall consider the evidence and any statement of the accused. If the court is satisfied that he is subject to naval law under this Act and the court is also of opinion that there is sufficient evidence to justify trial of such person for an offence of desertion or absence without leave then, unless he is in custody for some other cause, the court shall cause him to be delivered into naval custody or commit him as aforesaid, but otherwise shall discharge him :

Provided that if any such person is in custody for some other reason the court may if it thinks fit, and in its discretion, act in accordance with this subsection.

(4) If proceedings are taken in a magistrate's court under this section, the law applicable in that court in relation to the constitution and procedure of magistrates' court holding preliminary inquiries and conferring powers of adjournment and remand on such court so acting, and as to evidence and the issue and enforcement of summonses or warrants to secure the attendance of witnesses, shall apply to such proceedings.

(5) Notwithstanding the provisions of any other Act or rule of law, a person appearing before a magistrate's court under this section, shall not be admitted to bail.

Deserters and absentees without leave surrendering to police.

168.—(1) Where a person elsewhere than at a police station surrenders himself to a police officer as being illegally absent from the navy, the police officer shall forthwith bring him to a police station. The police officer in charge of any such police station shall thereupon enquire into the case, and if it appears that such person is illegally absent from the navy, he may in his discretion, cause such a person to be delivered into naval custody without bringing him before a magistrate's court, or may bring him before such court.

(2) Notwithstanding the provisions of any other Act or rule of law, the person appearing before a magistrate's court under this section, shall not be admitted to bail.

Certificates of arrest or surrender.

169.—(1) Where a magistrate's court under this Part of this Act deals with a person as illegally absent, and that person is delivered into naval custody there shall at the time of such delivery be handed over a certificate in the prescribed form signed by a magistrate, containing particulars as to the arrest or surrender as the case may be, and of the proceedings before the court.

(2) Where after surrender a person is delivered into naval custody without being brought before a court, under the provisions of this or any other Act, there shall be handed over a certificate in the prescribed form signed by the police officer causing the delivery into naval custody, and such certificate shall contain particulars relating to the surrender,

(3) In any proceedings for an offence under section forty-nine or fifty of this Act—

5 (a) a document purporting to be a certificate under the relative subsection of this section, or under the corresponding provisions of any other Act relating to service law and to be signed as therein presented, shall be evidence of the matter stated in the document ;

10 (b) where the proceedings are against a person who has been taken into naval custody on arrest or surrender, a certificate in the prescribed form purporting to be signed by a provost officer or any corresponding officer of a force raised under the law of any other country, or by any other officer in charge of the guardroom or other place where that person was confined on being taken into custody, stating the fact, date, time and place of arrest or surrender shall be evidence of the matter stated in the certificate.

15 170.—(1) It shall be the duty of the superintendent or other person in charge of a civil prison to receive any person duly committed to that prison by a magistrate's court as illegally absent from the navy and to detain him until in accordance with the directions of the court he is delivered into naval custody.

Duties of superintendents of prisons and others to receive deserters and absentees.

20 (2) Subsection (1) of this section shall apply to the person having charge of any police station or other place (not being a prison) provided for the confinement of persons in custody as it applies to the superintendent of a prison.

*Offences relating to Naval Matters punishable by Civil Courts*

25 171. Any person who falsely represents himself to any naval, military, airforce or civil authority to be a deserter from the navy shall be guilty of an offence and liable on conviction to a fine not exceeding fifty pounds or to imprisonment for a term not exceeding three months or to both.

Punishment for pretending to be a deserter.

30 172. Any person who—

(a) procures or persuades any officer or rating of the navy to desert or to absent himself without leave ; or

(b) knowing that any such officer or rating is about to desert or absent himself without leave, assists him in so doing ; or

35 (c) knowing any person to be a deserter or absentee without leave from the navy, conceals him or assists in his rescue from custody, shall be guilty of an offence and liable on conviction to a fine not exceeding fifty pounds or to imprisonment for a term not exceeding one year, or to both.

Punishment for procuring and assisting desertion.

40 173. Any person who wilfully obstructs or otherwise interferes with any officer or rating of the navy acting in the execution of his duty shall be guilty of an offence and liable on conviction to a fine not exceeding fifty pounds or to imprisonment for a term not exceeding three months, or to both.

Punishment for obstructing members of the navy.

45 174. Any person who—

(a) produces in any officer or rating of the navy any sickness or disability ; or

Punishment for aiding malingering.

(b) supplies to or for him any drug or preparation calculated or likely to render him, or lead to the belief that he is, permanently or temporarily unfit for service,

with a view to enabling him to avoid naval service, whether permanently or temporarily, shall be guilty of an offence and liable on conviction to a fine not exceeding fifty pounds or to imprisonment for a term not exceeding one year, or to both. 5

Unlawful purchase, etc., of naval stores.

175.—(1) Any person who acquires any naval stores or solicits or procures any person to dispose of any naval stores, or acts for any person in the disposing of any naval stores shall be guilty of an offence, unless he proves either— 10

(a) that he did not know, and could not reasonably be expected to know, that the chattels in question were naval stores ; or

(b) that those chattels had (by the transaction with which he is charged or some earlier transaction) been disposed of by order or with the consent of the board or of some person or authority who had, or whom he had reasonable cause to believe to have, power to give order or consent ; or 15

(c) that those chattels had become the property of an officer who had retired or ceased to be an officer, or of a rating who had been discharged, or of the personal representative of a person who had died, 20

and shall be liable on conviction to a fine not exceeding five hundred pounds or imprisonment for a term not exceeding two years, or to both.

(2) A police officer may arrest without warrant any person whom he has reasonable grounds for suspecting of having committed an offence against this section, and may seize any property which he has reasonable grounds for suspecting of having been the subject of the offence. 25

(3) Any person authorised to issue a warrant for the arrest of a person charged with a crime may, if satisfied by evidence on oath that a person within his jurisdiction has, or is reasonably suspected of having in his possession any property which has been the subject of an offence against this section, grant a warrant to search for such property as in the case of stolen goods ; and any property suspected of having been the subject of such an offence which is found on such a search shall be seized by the officer charged with the execution of the warrant, and that officer shall bring the person in whose possession or keeping the property is found before a magistrate's court. For the purpose of this subsection property shall be deemed to be in the possession of a person if he has it under his control, and whether he has it for his own use or benefit or for the use or benefit of another. 30 35 40

(4) In this section—

“acquire” means buy, take in exchange, take in pawn or otherwise receive (whether apart from this section the receiving is lawful or not) ;

“dispose” means sell, give in exchange, pledge or otherwise hand over (whether apart from this section the handing over is lawful or not) ; 45

- “naval stores” means any chattel of any description belonging to the government of the Federation, which has been issued for use for naval purposes or is held in store for the purpose of being issued when required, and includes any chattel which had belonged, and had been
- 5 issued or held, as aforesaid at some past time.

176.—(1) Any person who—

(a) as a pledge or a security for a debt ; or

(b) with a view to obtaining payment from the person entitled thereto of a debt due either to himself or to any other person,

- 10 receives, detains or has in his possession any official document issued in connection with the payment to any person of any pay, pension, allowance, gratuity or other payment payable in respect of his or any other person's naval service shall be guilty of an offence against this section.

- 15 (2) Any person who has in his possession without lawful authority or excuse (the proof whereof shall lie on him) any such document as aforesaid or any official document issued in connection with the mobilization or demobilization of any of the armed forces of Nigeria or any member thereof, shall be guilty of an offence against this section.

- 20 (3) Any person guilty of an offence against this section shall be liable on conviction to a fine not exceeding fifty pounds or to imprisonment for a term not exceeding six months, or to both.

- (4) For the purposes of this section a document shall be deemed to be in the possession of a person if he has it under his control and whether
- 25 he has it for his own use or benefit or for the use or benefit of another.

177.—(1) Any person who—

(a) without authority uses or wears any naval decoration, or any badge, wound stripe or emblem supplied or authorised by the President or the board ; or

- 30 (b) uses or wears any decoration, badge, wound stripe or emblem so nearly resembling any naval decoration, or any such badge, stripe or emblem as aforesaid, as to be calculated to deceive ; or

- (c) falsely represents himself to be a person who is or has been entitled to use or wear any such decoration, badge, stripe or emblem
- 35 as is mentioned in paragraph (a) of this section,

shall be guilty of an offence against this section :

Provided that nothing in this subsection shall prohibit the use or wearing of badges, emblems, broches or ornaments representing them.

- 40 (2) Any person who purchases or takes in pawn any naval decoration awarded to any member of the armed forces of Nigeria, or solicits or procures any person to sell or pledge any such decoration, or acts for any person in the sale or pledging thereof, shall be guilty of an offence against this section unless he proves that at the time of the alleged offence the person to whom the decoration was awarded was dead or
- 45 had ceased to be a member of those forces.

(3) Any person guilty of an offence against this section shall be liable on conviction to a fine not exceeding fifty pounds or to imprisonment for a term not exceeding three months, or to both.

Illegal dealings in documents relating to pay, pensions, mobilisations, etc.

Unauthorised use of, and dealing in, decorations, etc.

Intoxicating liquor not to be conveyed on board any naval ship.

178.—(1) Any person who shall, without the previous consent of the commanding officer, bring on board any naval ship any spirituous or fermented liquor of any description, or without such consent approach or hover about any such ship for the purpose of bringing on board, giving or selling spirituous or fermented liquor, shall be guilty of an offence against this section and shall be liable on conviction to a fine not exceeding ten pounds or imprisonment for a term not exceeding three months, or to both.

(2) Any officer or petty officer of the navy may, with or without ratings or persons under his command, search any vessels hovering about or approaching any ship of the navy, in circumstances giving rise to a reasonable suspicion that an offence under subsection (1) of this section is intended; and if on search any such liquor is found in or upon such vessel, the officer or petty officer may seize it, and such liquor shall be forfeited.

#### Evidence

Special provisions as to evidence.

179.—(1) The following provisions shall have effect with respect to evidence in proceedings under this Act, whether before a court martial, a civil court or otherwise.

(2) A document purporting to be a copy of the attestation paper signed by any person and to be certified to be a true copy by a person stated in the certificate to have the custody of the attestation paper shall be evidence of the enlistment of the person attested.

(3) The attestation paper purporting to be signed by a person on his enlistment shall be evidence of his having given the answers to questions which he is therein recorded as having given.

(4) A letter, return or other document stating that any person—

(a) was or was not serving at any specified time or during any specified period in the navy or the reserve or was discharged from the navy or the reserve at or before any specified time; or

(b) held or did not hold at any specified time any specified rank or appointment in the navy or the reserve, or had at or before any specified time been attached, posted or transferred to any naval ship or establishment, or at any specified time or during any specified period was or was not serving or held or did not hold any rank or appointment in any particular country or place; or

(c) was or was not at any specified time authorised to use or wear any decoration, badge, wound stripe or emblem, shall, if purporting to be issued by or on behalf of the commander, be evidence of the matter stated in the document.

(5) A record made in any service book or other document prescribed by regulations under this Act for the purposes of this subsection, being a record made in pursuance of service law or regulations, or otherwise in pursuance of naval duty, and purporting to be signed by the commanding officer or by any person whose duty it was to make the record, shall be evidence of the facts stated therein; and a copy of a record (including the signature thereto) in any such book or other document as aforesaid, purporting to be certified to be a true copy by a person stated in the certificate to have the custody of the book or original document, as the case may be, shall be evidence of the record.

(6) A document purporting to be issued by order of the board or the commander and to contain instructions or orders given or made by the board or the commander shall be evidence of the giving of the instructions or making of the orders and of their contents.

5 (7) A certificate purporting to be issued by or on behalf of the board or the commander and stating—

(a) that a decoration of a description specified in or annexed to the certificate is a naval decoration ; or

10 (b) that a badge, wound stripe or emblem of a description specified in or annexed to the certificate is one supplied or authorised by the President or the board,

shall be evidence of the matter stated in the certificate.

(8) A certificate purporting to be signed by a person's commanding officer or any officer authorised by him to give the certificate, and stating the contents of, or any part of, standing orders or other routine orders of a continuing nature made for any naval ship or naval establishment, shall in the proceedings against the said person be evidence of the matters stated in the certificate.

15

20 **180.**—(1) Where a person subject to this Act has been tried before a civil court (whether at the time of the trial he was so subject or not), a certificate signed by a judge or a magistrate and stating all or any of the following matters—

Proof of  
outcome of  
civil trial.

(a) that the said person has been tried before the court for an offence specified in the certificate ;

25 (b) the result of the trial ;

(c) what judgment or order was given or made by the court ;

(d) that other offences specified in the certificate were taken into consideration at the trial,

30 shall for the purposes of this Act be evidence of the matters stated in the certificate.

(2) A document purporting to be a certificate under this section and to be signed by a judge or a magistrate shall, unless the contrary is shown, be deemed to be such a certificate.

35 **181.**—(1) The original proceedings of a court martial under service law purporting to be signed by the president of the court and being in the lawful custody of the commander or of any person having the lawful custody thereof shall be admissible in evidence on production from that custody.

Evidence of  
proceedings  
of court  
martial.

40 (2) A document purporting to be a copy of the original proceedings of a court martial under service law or any part thereof and to be certified by the commander or any person authorised by him, or any other person having the lawful custody of the proceedings, to be a true copy shall be evidence of the contents of the proceedings or the part to which the document relates, as the case may be.

45 (3) This section applies to evidence given in any court, whether civil or criminal.

*Reductions in Rank*

- Restrictions on disrating.
- 182.—(1) A chief petty officer shall not be disrated except by sentence of a court martial under service law or by order of the Commander.
- (2) A petty officer shall not be disrated except— 5
- (a) by sentence of a court martial under service law ; or
- (b) in the case of a petty officer or a leading rating, by award or order of the commander or of an officer by whom the commander's powers of disrating are exercisable by virtue of this Act ; or
- (c) in the case of an able rate, by award or order of his commanding officer. 10
- (3) Where it appears to the commander that a chief petty officer or a petty officer or a leading rating is unable to perform satisfactorily the functions of his rating, the commander may by order reduce the chief petty officer or petty officer to such rating as may be specified by the order or to ordinary rating ; and where it appears to a commanding officer that a leading rating serving under his command is unable to perform satisfactorily the functions of his rating, the commanding officer may by order reduce the leading rating to ordinary rating. 15
- (4) The commander may by order direct that the powers conferred upon him by this Act to disrate any petty officer or a leading rating, may be exercised by officers not below the rank of captain under whose command the petty officers are serving ; and references in those subsections to the commander shall be construed accordingly. 20
- (5) For the purposes of this section disrating does not include reversion from acting rate. 25

*Miscellaneous Provisions*

- Temporary reception into civil custody of persons under escort.
- 183.—(1) Where a person in naval custody when charged with, or with a view to his being charged with, an offence against Part IV or the corresponding provisions of any other service law, it shall be the duty of the superintendent or other person in charge of a civil prison, or of the person having charge of any police station or other place in which prisoners may be lawfully detained, upon delivery to him of a written order purporting to be signed by the commanding officer of the person in custody to receive him into his custody for a period not exceeding seven days. 30
- (2) In this section "civil prison" has the meaning ascribed to it in section one hundred and thirty-six of this Act. 35
- Avoidance of assignment of, or charge on, naval pay, etc.
- 184.—(1) Every assignment of or charge on, and every agreement to assign or charge, any pay, naval award, grant, pension or allowance payable to any person in respect of his or any other pension's service in the armed forces of Nigeria shall be void. 40
- (2) Save as expressly provided by this Act, no order shall be made by any court the effect of which would be to restrain any person from receiving anything which by virtue of this section he is precluded from assigning and to direct payment thereof to another person. 45
- (3) Nothing in this section shall prejudice any enactment providing for the payment of any sum to a bankrupt's trustee in bankruptcy for distribution among creditors.

185.—(1) An officer of a rank not below that of lieutenant-commander (in this Act referred to as an "authorised officer") may, outside Nigeria, take statutory declarations from persons subject to this Act.

Power of certain officers to take statutory declarations.

5 (2) A document purporting to have subscribed thereto the signature of an authorised officer in testimony of a statutory declaration being taken before him in pursuance of this section and containing in the jurat or attestation, a statement of the date on which and the place at which the declaration was taken and of the full name and rank of that officer shall be admitted in evidence without proof of the signature being  
10 the signature of that officer or of the facts so stated.

#### PART VIII—RESERVISTS AND PENSIONERS

186. Notwithstanding the provisions of section one hundred and ninety-four, this Part of this Act shall apply—

Reservists and pensioners.

15 (a) to every officer or rating who by virtue of this Act, is a member of the reserve; and

(b) to every person who having served as an officer or rating in the navy is in receipt of a pension or annual allowance in respect of such service, and in this Act is referred to as a pensioner.

187.—(1) Every reservist shall be liable to be called out for training at such a place and for such periods not exceeding twenty-eight days in any one year as may be specified in regulations made under section one hundred and ninety-three of this Act.

Annual training.

(2) Every reservist may, during any training for which he may be called out, be attached to and trained in any ship, vessel or establishment.

188.—(1) The President may, at any time when occasion appears to require, call out reservists and pensioners or as many of them as he thinks necessary, to aid the civil power in the preservation of the public peace.

Calling out of reservists and pensioners to aid the civil power.

30 (2) Reservists and pensioners called out for service under this section shall not be liable to serve at any one time for a period exceeding twenty-eight days.

189.—(1) In the event of a state of war being declared or of insurrection, hostilities or public emergency it shall be lawful for the President, by proclamation, to call out any reservists and pensioners on permanent service. The President may, in any such proclamation give, or authorise the Minister to give, such directions as may seem necessary or proper for calling out such reservists and pensioners.

Calling out of reservists and pensioners on permanent service.

40 (2) A proclamation under this section and directions given in pursuance thereof shall be obeyed, and every reservist and pensioner called out by such directions shall attend at the place and time fixed by those directions, and at and after that time shall be deemed to be called out on permanent service.

45 (3) Every reservist or pensioner when called out on permanent service shall be liable to serve as an officer or rating of the navy until he is released or discharged.

- Punishment for non-attendance.
- 190.—(1) Any reservist or pensioner who, without leave lawfully granted or other reasonable excuse, fails to appear at the time and place appointed for annual training, or when called out to aid the civil power or on permanent service, shall—
- (a) if called out on permanent service, be guilty, according to the circumstances, of desertion within the meaning of section forty-nine of this Act or of absenting himself without leave within the meaning of section fifty of this Act ; or 5
- (b) if called out to aid the civil power or for annual training, be guilty of absenting himself without leave within the meaning of section fifty of this Act. 10
- (2) Any reservist or pensioner who commits any offence under this section shall be liable—
- (a) to be tried by court martial, and, on conviction, to suffer imprisonment for a term not exceeding two years or such less punishment as is provided by this Act ; or 15
- (b) to be tried by a magistrate's court and, on conviction, be liable to a fine not exceeding fifty pounds, or to imprisonment for a term not exceeding two years.
- (3) Section eighty-five and sections one hundred and sixty-six to one hundred and seventy inclusive shall apply to reservists and pensioners who commit, or are alleged to have committed, or are reasonably suspected of having committed, an offence against this section as they apply to persons otherwise subject to naval law under this Act. 20
- Record of illegal absence.
191. Where a reservist fails to appear at the time and place appointed for annual training or where a reservist or pensioner fails to appear when called out to aid the civil power or on permanent service, and his absence continues for not less than twenty-one clear days, an entry of such absence shall be made by an officer in the service books prescribed by regulations made under this Part of this Act and such entries shall be *prima facie* evidence of the fact of such absence. 25
- Discharge during service.
192. A reservist or pensioner may be discharged by the commander at any time during the currency of any term of service as a reservist or pensioner, as the case may be, in accordance with regulations made under this Part of this Act. 30
- Regulations as to reservists and pensioners.
193. The President may make regulations with respect to the government and discipline of the reservists and pensioners, and, without prejudice to the generality of the foregoing regulations may provide for—
- (a) the calling out for training of reservists ; 40
- (b) the calling out of reservists and pensioners to aid the civil power and on permanent service ;
- (c) the pay of reservists when on the reserve and for the pay of reservists and pensioners when called out under this Part of this Act ;
- (d) requiring reservists and pensioners to report themselves from time to time, and to obtain the permission of the commander, or such other officer so authorized by regulations, before leaving Nigeria ; and 45
- (e) any matter which is required by this Part of this Act to be prescribed.

## PART IX.—APPLICATION OF THE ACT AND SUPPLEMENTARY PROVISIONS

*Application*

194.—(1) The following persons shall be subject to this Act—

Application  
of the Act.

(a) officers and ratings of the navy ;

5 (b) officers of the reserve and pensioners when called out on service ; and

(c) reservists called out for training, to aid the civil power or on permanent service ;

10 (d) pensioners called out to aid the civil power or on permanent service.

(2) This Act shall apply to the persons subject thereto under the provisions of this section and in relation to the units raised under this Act as well outside as within Nigeria.

15 195.—(1) The provisions of this or any other Act in so far as they contain or refer to the word "rating" or other word importing reference to persons of the male sex only as, or as having been, members of the navy and accordingly subject to service law under this Act, shall have effect as if for any such word there had been substituted therein words having a like meaning in other respects but importing a reference to

Application  
of the Act to  
women.

20 persons of either sex.

(2) In relation to women members of the navy, this Act shall have effect subject to the following modifications—

(a) so much of Parts I, II, III and VIII as relate to service in, and transfer to, the reserve shall not apply ;

25 (b) the punishment of extra work or drill specified in the First Schedule shall not apply ;

(c) references in sections two hundred and two hundred and two of this Act to a widow shall be construed as references to a widower.

30 196.—(1) Subject to the modifications specified in subsection (2) of this section, where any unit is on active service, and a person is employed in the service of that unit or any part thereof or accompanies such unit or part thereof and is not otherwise subject to service law, Part IV of this Act shall apply to the person so employed or accompanying the unit as the said Part applies to members of the navy.

Application  
of the Act  
to civilians.

53 (2) The modifications referred to in subsection (1) of this section are as follows :—

(a) the punishments which may be awarded by a court martial shall include a fine, but shall not include any other punishment less than imprisonment ;

40 (b) the punishment which may be awarded where a charge is dealt with summarily shall, in the case of any offence, be a fine not exceeding ten pounds, but no other punishment ;

45 (c) the following provision shall have effect in substitution for subsections (2) to (4) inclusive of section eighty-five of this Act, that is to say that a person may be arrested by a provost officer, by any chief petty officer or petty officer legally exercising authority under a provost officer or on his behalf, or by order of any officer ;

(d) the provisions of this Act relating to the investigation of, and summary dealing with, offences shall, save as otherwise expressly provided, apply as they apply to ratings ;

(e) for the purposes of the provisions of this Act relating to the investigation of offences, the commanding officer shall be such officer as may be appointed by an officer authorised to convene a court martial ;

(f) for references in sections one hundred and twenty-three and one hundred and twenty-four to being, continuing, or ceasing to be subject to naval law under this Act there shall be substituted references to being, continuing to be or ceasing to be in such circumstances that Part IV applies, and subsection (3) of section one hundred and twenty-three shall not apply.

(3) Any fine awarded by virtue of this section, whether by a court martial or the commanding officer, shall be recoverable as a debt due to the Government of the Federation.

197. The provisions of Part IV of this Act shall, to such extent and subject to such modifications as may be prescribed by regulations made by the President, apply to persons embarked as passengers on board ships or aircraft of the navy (not being persons who are subject to this Act by virtue of any of the provisions of this Act or are subject to military or air force law), as they apply to persons subject to this Act.

#### *Wills and Distribution of Property*

198.—(1) Every rating on enlistment shall declare the name of the person or persons to whom, in event of his dying without having made a valid will, any money or personal property due or belonging to him should be paid or delivered ; or a rating may direct that his estate is to be administered by the customary court (by whatever name called) of some named place according to the customs of his tribe. The name of such person or customary court shall be recorded on his attestation paper, and the record shall be verified periodically. It shall be the duty of the rating to report any alteration in the record which he wished made.

(2) Any officer of the navy or of the Accountant-General or any public department, having in his or its charge or control any pay, accumulations of pay, gratuity or other allowance, or any personal property or money belonging to any rating dying intestate who has complied with the above conditions, may pay or deliver the same to the person whose name has been recorded, or to a customary court of the place named by the rating, in the manner prescribed.

199.—(1) Any will made by a rating shall be valid for disposing of any money or personal property which is due or belonging to him at his decease if it is in writing and signed or acknowledged by him in the presence of, and in his presence attested by one witness, being an officer of the navy or any government medical officer. The will shall be deemed well made for the purpose of being admitted to probate, and the person taking out representation to the testator under such will shall exclusively be deemed the testator's representative with respect to the money or personal property thereby bequeathed.

(2) Any officer of the navy or of the Accountant-General or any public department, having in his or its charge or control any pay, accumulation of pay, gratuity or other allowance, or any personal property or money belonging to such testator, not exceeding in the

Application  
of the Act to  
passengers.

Ratings on  
enlistment to  
register the  
name of  
person to  
whom estate  
is to be paid  
in event of  
his dying  
intestate.

Ratings'  
wills : special  
provisions.

aggregate the value of one hundred pounds, may pay or deliver the same to any person entitled thereto under the will, or to the person entitled to procure probate of or administration under such will, although probate or administration may not have been taken out.

- 5 (3) If the value of the money and personal property exceeds one hundred pounds, the paymaster or other officer or public department, having charge or control thereof shall require probate or administration to be taken out and thereupon pay or deliver the said money and effects to the legal representative of the deceased.

- 10 200. If any rating dies without having complied with the requirements of this Part of this Act as to the disclosure of next of kin or has not made a will valid under this or any other enactment relating to wills and for the time being in force, any officer of the navy or the Accountant-General or any public department having in his or its charge or control
- 15 money or personal property of the deceased may, with the concurrence of the commander or an officer acting on behalf of the commander, pay or deliver such money or personal property to any claimant who proves to the satisfaction of the commander or such officer, relationship as the widow of the deceased or the child or other near relative of the
- 20 deceased, as the case may be, according to the rules of succession of the tribe to which the deceased belonged. If there are more of such claimants than one, payment or delivery may be made in such shares and proportions as the claimant would be entitled to receive under the rules of succession prevailing among such tribe, or as nearly as may be.

Distribution  
in case of  
deceased  
rating's  
intestacy.

- 25 (2) Where the rating was a moslem, the distribution of the estate may be carried out by the alkali's court of the district from which the deceased person came, and the alkali shall be responsible to the regional Administrator-General or the Federal Administrator-General as the case may require, for the carrying out of the distribution in accordance
- 30 with Islamic law. If there is no such court in the district, the distribution may be made as nearly as may be in accordance with such law.

- 201.—(1) Where probate of the will or administration with or without the will annexed of the estate of a deceased rating is not taken out, and an officer of the navy, the Accountant-General or officer of any
- 35 public department, before disposing of the money and personal property of the deceased has notice of any debt due by the deceased, he shall, anything to the contrary in this Part of this Act notwithstanding, apply such money and property as may remain in his authority or control, or so much thereof as may be requisite in or towards the payment of such
- 40 debt, if he is satisfied—

Payment of  
debts of  
deceased  
rating.

- (a) that the claimant has proved the debt to the satisfaction of the commander or of the officer acting on behalf of the commander; and
- (b) that a demand for the payment of the debt was made within one year after such death; and
- 45 (c) that the debt was incurred within three years before the death of the rating.

- (2) A person claiming to be a creditor of a deceased rating shall not be entitled to obtain payment of his debt out of any money in the hands of any officer of the navy or of the Accountant-General or any public
- 50 department, except by means of a claim on any officer responsible for a rating's pay, and proceedings thereon under and in accordance with this

Act. If the estate is being administered by a customary court, any government debt shall be paid by the officer concerned before the balance of the estate is passed to the customary court, and that court shall thereafter be responsible to see that all other debts are settled before final distribution of the estate of the deceased rating under this section. 5

Property of deceased rating distributed subject to rights of creditors.

202. Where money or personal property of a deceased rating or any part thereof is paid or delivered to any person recorded as next of kin under this Part of this Act or as beneficiary under the will of the deceased or as his widow or child, or otherwise in accordance with this Act as a near relative, any creditor of the deceased shall have the same rights and remedies against the person to whom the money or personal property is paid or delivered as if such person had received the money or personal property as legal personal representative of the deceased. 10

Deceased rating's money undisposed of applied to prescribed fund.

203.—(1) Subject to the provisions of this section, if money or personal property belonging to a deceased rating, or any part thereof, remains for one year undisposed of or unappropriated, and without any valid claim thereto having been made, it shall after conversion into cash where necessary, be paid over to the Accountant-General and be applied towards forming a fund for the benefit of ratings and ex-ratings of the navy who are in distress, or for the benefit of the navy generally, or for charitable purposes. 15 20

(2) The application under the foregoing subsection of any such money or property or part thereof towards such fund shall not be a bar to any subsequent claim by any person, established within twelve months after such application. 25

(3) The Minister after consultation with the board, may make regulations for the formation of the fund and any disbursements may be made out of such fund in accordance with the regulations. The regulations may provide for the fund to be identical with the Nigerian Navy Benefit Fund under this Act or for the fund to be a separate fund administered for the purposes of this section. 30

Application of money, etc., in case of desertion.

204. Money or other property of a deserter under this Act in charge or control of an officer of the navy, the Accountant-General or any public department shall be disposed of as nearly as may be in accordance with the provisions of section two hundred and one of this Act or as may otherwise be prescribed under this Act, and if that section is invoked it shall have effect accordingly. 35

Uniforms, medals and decorations of deceased rating.

205. Notwithstanding any other provisions of this Act, uniforms, medals and decorations shall not comprise part of the personal estate of any deceased rating for the purpose of satisfying claims of creditors or for any of the purposes of administration under this Act or otherwise, and they shall be delivered to and held by the commander or officer authorised by him and be disposed of in such manner as may be prescribed. 40

#### Miscellaneous

45

Power to make regulations generally.

206. The President may in any case not otherwise provided for under this Act make regulations generally for prescribing or providing for an act, matter or thing.

207.—(1) Any power conferred by this Act to make regulations, rules, orders or other instruments shall include power to make provision for specified cases or classes of cases, and to make different provisions for different classes of cases, and for the purposes of any such instrument

5 classes of cases may be defined by reference to any circumstances specified in the instrument.

Powers exercisable in subsidiary legislation.

(2) Any such regulations, rules, orders or other instruments as aforesaid may impose conditions, require acts or things to be performed or done to the satisfaction of any person named therein whether or not

10 such persons are members of the navy, empower such persons to issue orders either orally or in writing requiring acts or things to be performed or done or prohibiting acts or things from being performed or done, and prescribe periods or dates upon, within or before which such acts or things shall be performed or done or such conditions shall be fulfilled

15 and provide for appeal against any such order, requirement or direction.

208.—(1) In this Act the expression "on active service" in relation to any unit means that it is engaged in operations against an enemy, and in relation to a person means that he is serving in or with such a unit which is on active service.

Provisions as to active service.

(2) Where it appears to the President that, by reason of the imminence of active service or of the recent existence of active service, it is necessary for the service of the public that a unit should be deemed to be or continue to be on active service he may declare that for such period, not exceeding three months, beginning with the coming into force of the

25 declaration as may be specified therein that unit shall be deemed to be on active service.

(3) Where it appears to the President that it is necessary for the service of the public that the period specified in a declaration under subsection (2) of this section should be prolonged or, if previously

30 prolonged under this subsection should be further prolonged, he may declare that the said period shall be prolonged by such time, not exceeding three months, as may be specified in the declaration under this subsection.

(4) If at any time while any unit is deemed to be on active service

35 by virtue of the foregoing provisions of this section, it appears to the President that there is no necessity for the unit to continue to be treated as being on active service, he may declare that as from the coming into operation of the declaration the unit shall cease to be, or to be deemed to be, on active service.

209. An order or determination by a naval officer or naval authority may, unless otherwise prescribed by rules or regulations made under this Act, be signified under the hand of any officer authorised in that behalf; and any instrument signifying such an order or determination and purporting to be signed by an officer stated therein to be so authorised

45 shall unless the contrary is proved, be accepted by all courts and persons as sufficient evidence accordingly.

Execution of orders, instruments, etc.

210.—(1) All fines awarded under Part IV and section one hundred and ninety-six of this Act shall be paid over to the Accountant-General and be applied towards forming a fund to be known as the Nigerian

50 Navy Benefit Fund for the purpose of making money available to the benefit of ratings and ex-ratings of the navy who are in distress, or for the benefit of the navy generally, or for charitable purposes.

Nigerian Navy Benefit Fund.

(2) The minister, after consultation with the board, may make regulations for the formation of the benefit fund, and any disbursements may be made out of such fund in accordance with the regulations.

Rights of officers.

211. Officers of the navy shall have and enjoy the like powers, rights, immunities and privileges as are by any means conferred upon and enjoyed by commissioned officers of any other of the armed forces of Nigeria.

Application of other Acts.

212.—(1) The President may, by order, apply, with all necessary modifications and adaptations, in relation to the board, the chairman of the board and the navy (as well officers and rating as property and institutions) any of the enactments relating to the Army Council, the Minister of Defence and to the Army (as well officers and other ranks as military property and institutions).

(2) Where any enactment is to be applied under the foregoing subsection, the expression "enactment" shall include any enactment conferring powers, rights, exemptions or abatements from taxation or immunities, or imposing duties or disabilities on such officers or airmen, or other ranks, as the case may be.

Repeal and transitional provisions.

213.—(1) The enactment set out in the Fourth Schedule to this Act are repealed to the extent specified in the second column of that Schedule.

(2) The transitional provisions set out in the Third Schedule to this Act shall have effect in connection with the repeal of the Royal Nigerian Navy Act, 1960.

Savings.

214. Notwithstanding the provisions of subsection (1) of section two hundred and thirteen of this Act all ratings who were raised under the Royal Nigerian Navy Act, 1960, and serving in the navy on the day on which this Act comes into operation shall be deemed to have been enlisted under this Act but such ratings shall not be required to serve in the navy for a longer period than that for which they were required to serve at the time of their original enlistment or re-engagement.

Interpretation.

215.—(1) In this Act, unless the context otherwise requires—

"Accountant-General" means the Accountant-General of the Federation ;

"acting rank" means rank of any description in the navy and however called and being such that a commanding officer may, with or without preferring a charge under this Act, order the holder to revert to a lower rank or to his substantive rank as the case may be, and "acting chief petty officer" and "acting petty officer" shall be construed accordingly ;

"aircraft" means any machine for flying, whether propelled by mechanical means or not, and includes any machine of the type known as a hovercraft as well as any description of balloon ;

"the air council" means the air council established under section three of the Air Force Act, 1964 ;

"aircraft material" includes—

(a) parts of, and components of or accessories for, aircraft, whether for the time being in aircraft or not,

(b) engines, armaments, ammunition and bombs and other missiles of any description in, or for use in, aircraft,

(c) any other gear, apparatus or instruments in, or for use in, aircraft,

5 (d) any apparatus used in connection with the taking-off or landing of aircraft or for detecting the movement of aircraft, and

(e) any fuel used for the propulsion of aircraft and any material used as a lubricant for aircraft or aircraft material ;

10 "aircraft papers" includes books, documents, forms and writings of whatsoever description and whether or not relating to the flight of the aircraft when captured or to any other flight, which are delivered up or found aboard such aircraft ;

"the air force" means the Nigerian air force raised under the Air Force Act, 1964 ;

15 "air signal" means any message, signal or indication given, by any means whatsoever, for the guidance of aircraft or a particular aircraft ;

"allied forces" means military, naval or air forces of any country allied to, or associated with, the Federation and includes any Commonwealth force ;

20 "armed forces of Nigeria" means any of the military, naval and air forces raised by the Government of the Federal Republic of Nigeria ;

"the Army" means the Nigerian army raised under the Nigerian Army Act, 1960 ;

25 "the army council" means the Nigerian army council established under section six of the Nigerian Army Act, 1960 ;

"arrest" includes open arrest ;

"before the enemy", in relation to a person, means that he is in action against the enemy or about to go into action against the enemy or is under attack or threat of imminent attack by the enemy ;

30 "the board" means the Navy Board established under section three of this Act ;

"Boards of Inquiry Rules" means rules regulating boards of inquiry made under this Act ;

35 "civil court means a court of competent criminal jurisdiction, but does not include any customary court by whatever name called ;

"civil offence" has the meaning assigned to it in subsection (2) of section eighty-two of this Act ;

"commanding officer", in relation to any person, means the officer commanding the unit to which the person belongs or is attached ;

40 "corresponding rank", in relation to any rank of any other of the armed forces of Nigeria or an allied force means such rank in that force as may be declared under this Act to correspond with a rank under this Act ;

45 "court martial", save where expressed to be under service law, means a court martial under this Act ;

"damage" and cognate expressions include destruction ;

"date of attestation", in relation to any person, means the date on which he is attested as having enlisted in the navy ;

- "decoration" includes any medal, medal ribbon, clasp and good conduct badge ;
- "desertion" shall be construed in accordance with subsection (3) of section forty-nine of this Act ;
- "enemy" means all persons engaged in armed operations against Nigeria or allied forces, and includes armed mutineers, armed rebels, armed rioters and pirates ; 5
- "executive officer" means the officer carrying out the executive duties of the ship or establishment ;
- "imprisonment rules" means rules regulating imprisonment made by the President under this Act ; 10
- "independent command" means a ship whose officers and men are appointed or drafted direct to her and borne on her books ;
- "junior rating" means a rating enlisted in accordance with the provisions of subsection (2) of section sixteen ; 15
- "the Minister" means the Minister charged with responsibility for matters relating to Defence ;
- "the navy" means the Nigerian Navy ;
- "naval service" means service under the provisions of this Act otherwise than service in the reserve ; 20
- "officer" means in relation to the navy, a person of or above the rank of cadet, and, in relation to any other forces, means an officer of rank corresponding to the said rank or any superior rank ;
- "petty officer" includes chief petty officers and petty officers and ratings of equivalent status in all branches, except when used as the title of seaman ratings ; 25
- "provost officer" means a provost marshal or officer appointed to exercise the functions conferred by or under service law on provost officers ;
- "public", when used adjectivally, means belonging to the Government of the Federation or of any Region thereof, or to the government of the country to which any allied force serving or operating in Nigeria belongs ; 30
- "rating" means a member of the navy of or below the rank of chief petty officer, and references in this Act to a rating, or to a rating of any particular rank, include references to a soldier or airman of rank corresponding with that rate, as the case may be ; 35
- "the reserve" means the body of naval personnel comprised of those persons who are subject to reserve service or liability under this Act ;
- "service" when used adjectivally, means belonging to or connected with the armed forces of Nigeria ; 40
- "service law" means this Act, the Nigerian Army Act, 1960, and the Air Force Act, 1964, and includes the military, naval or air force law of any allied force ;
- "ship" includes any description of vessel ;
- "ships papers" includes books, documents, forms and writings of whatsoever description and whether or not relating to the voyage of the ship when captured or to any other voyage, which are delivered up or found aboard such ship ; 45
- "steals" has the meaning assigned to it in the Criminal Code ;

"stoppages" means in relation to pay, the recovery by deductions from the pay of the offender, of a specified sum by way of compensation for any expense, loss or damage occasioned by the offence ;

5 "tender" means a ship or vessel whose officers and men are appointed or drafted to and borne on the books of another ship or vessel being a parent ship or vessel ;

"unit" means an establishment, base or any other formation of naval personnel which has been declared to be a unit by the board.

10 (2) Where by this Act it is provided that any person subject to naval law under this Act shall be liable on conviction by court martial to imprisonment and no term or maximum term is specified, the person so convicted shall be liable to imprisonment for any term.

15 216.—(1) This Act may be cited as the Navy Act, 1964, and shall come into operation on a day to be appointed by the President by order in the Gazette.

Short title, commencement and application.

(2) This Act shall apply throughout the Federation.

## SCHEDULES

### FIRST SCHEDULE

Section 89

A. Officers who can try ratings summarily and their powers of summary punishment

(i) *Commanding officer of a ship or establishment if of the rank of lieutenant or above*

<i>Punishment</i>	<i>Qualification</i>
1. Imprisonment	Not exceeding three calendar months. Warrant required
2. Dismissal from the navy	Warrant required
3. Detention	Not exceeding three calendar months. Warrant required
4. Disrating	Warrant required
5. Reduction to 2nd class for conduct	Warrant required
6. Deprivation of loyal services medal	Warrant required
7. Deprivation of good conduct badges	Warrant required
8. Severe reprimand by the captain	Only to leading ratings and above
9. Extra work and drill	Not exceeding 14 days
10. Stoppage of leave	Not exceeding 30 days
11. Mulcts for improper absence	

FIRST SCHEDULE—*continued*

<i>Punishment</i>	<i>Qualification</i>
12. Mulcts of pay for drunkenness	
13. Extra work or drill	Not exceeding 7 days, and for not longer than two hours on any one day
14. Reprimand	
(ii) <i>Commanding officer of a ship or establishment if below the rank of lieutenant</i>	
<i>Punishment</i>	<i>Qualification</i>
9. Extra work and drill	Not exceeding 7 days
10. Stoppage of leave	Not exceeding 14 days
11. Mulcts for improper absence	
12. Mulcts of pay for drunkenness	
13. Extra work or drill	Not exceeding 7 days, and for not longer than two hours on any one day
14. Reprimand	
(iii) <i>Executive officer (if of the rank of commander) when delegated with powers of punishment by the commanding officer</i>	
<i>Punishment</i>	<i>Qualification</i>
9. Extra work and drill	Not exceeding 14 days
10. Stoppage of leave	Not exceeding 14 days
13. Extra work or drill	Not exceeding 7 days and for not longer than two hours in one day.
14. Reprimand	
(iv) <i>Executive officer (if of the rank of lieutenant or above) when delegated with powers of punishment by the commanding officer.</i>	
<i>Punishment</i>	<i>Qualification</i>
9. Extra work and drill	Not exceeding 7 days
10. Stoppage of leave	Not exceeding 7 days but not to chief petty officers or petty officers if executive officer is below the rank of commander
13. Extra work or drill	Not exceeding 7 days and for not longer than two hours in one day
14. Reprimand	
(v) <i>Officer of the watch or day (if of the rank of lieutenant or above) when delegated with power of punishment by commanding officer, or a departmental officer of the rank of lieutenant or above when delegated with power by commanding officer to punish any rating of his department for an offence in connection with the duties of that department but not connected with the general duties of the ship or naval establishment</i>	
13. Extra work or drill	For one day only and for not longer than two hours on that day

FIRST SCHEDULE—*continued*

## B. Warrant Punishment

*Punishments No. 1 to No. 7 above inclusive (which may be known as warrant punishments) shall not have effect unless a warrant is made out, approved as required by the Schedule and formally read to the accused in public*

## C. Approval of warrants is required as follows :—

<i>Punishment</i>	<i>Approving Authority</i>
1. Imprisonment .. .. .	The Commander
2. Dismissal .. .. .	The Commander
3. Detention .. .. .	The Commander
4. Disrating .. .. .	The commander if in Nigerian waters or if on detached service an officer of captain's rank or above in the case of a Petty Officer or a leading seaman
5. Reduction to 2nd class for conduct	The commander if in Nigerian waters or if on detached service an officer of the rank of commander or above
6. Deprivation of Loyal Service Medal	The commander
7. Deprivation of good conduct badges	The commander if in Nigerian waters ; if on detached service, an officer of the rank of commander or above may approve the deprivation of one good conduct badge.

## SECOND SCHEDULE

## Section 102

*Alternative Offences of which Accused may be convicted by Court Martial*

<i>Offence Charged</i>	<i>Alternative Offence</i>
1. Communicating with or giving intelligence to the enemy, either with intent to assist the enemy or without authority	1. Disclosing information without authority
2. Any offence against subsection (1) of section forty-two	2. Any offence against subsection (2) of section forty-two
3. Striking his superior officer	3. (a) Using violence to his superior officer otherwise than by striking him, or (b) Offering violence to his superior officer.

SECOND SCHEDULE—*continued*

<i>Offence Charged</i>	<i>Alternative Offence</i>
4. Using violence to his superior officer otherwise than by striking him	4. Offering violence to his superior officer
5. Using threatening language to his superior officer	5. (a) Using insolent language to his superior officer, or (b) Behaving with contempt to his superior officer
6. Using insolent language to his superior officer	6. Behaving with contempt to his superior officer
7. Disobeying, in such a manner as to show wilful defiance of authority, a lawful command given or sent to the accused personally	7. Behaving with contempt to his superior officer
8. Desertion	8. Absence without leave
9. Attempting to desert	9. Absence without leave
10. Stealing any property	10. Fraudulently misapplying the property
11. Any offence under section sixty-three involving wilfulness	11. The corresponding offence involving negligence
12. Any offence against subsection (1) of section sixty-seven	12. Any offence against subsection (2) of section sixty-seven
13. Any offence against section sixty-eight involving striking	13. The corresponding offence involving the offering of violence
14. Any offence against section sixty-eight involving the use of violence other than striking	14. The corresponding offence involving the offering of violence

## THIRD SCHEDULE

Section 213

*Transitional Provisions*

1. In this Schedule "the old Act" means the Royal Nigerian Navy Act, 1960, repealed by this Act.

2.—(1) In relation to an offence against any section in Part V of the old Act or against Part I of the Naval Discipline Act, 1957, sections eighty-three to one hundred and twenty-two inclusive, sections one hundred and twenty-nine to one hundred and thirty-two inclusive and sections one hundred and thirty-five and one hundred and thirty-six and section one hundred and eighty-two of this Act shall apply as if

THIRD SCHEDULE—*continued*

the said section of the old Act had been contained in this Act and this Act had been in force when the offence was committed, and as if any finding or punishment having effect before the date upon which this Act comes into operation, and anything done before that day by virtue of or in relation to such a finding or sentence, had been come to, awarded or done under this Act :

Provided that nothing in this sub-paragraph shall render an offence capable of being tried by court martial or dealt with summarily, if by reason of the time or place of the commission of the offence it could not have been so tried or dealt with under the old Act.

(2) Notwithstanding anything in sub-paragraph (1) of this paragraph where any proceedings for such an offence as aforesaid have been begun before the date upon which this Act comes into operation, any step in the proceedings taken after that day shall be deemed to be validly taken if taken in accordance with the old Act and the rules made thereunder.

(3) In section one hundred and forty-seven of this Act (which provides against trial for offences already disposed of), references to this Act or to any provision thereof shall be construed as including respectively references to the old Act and to the corresponding provision thereof.

3. Where after the date upon which this Act comes into operation a person is alleged—

(a) to have committed an offence continuing over a period beginning before that day and ending thereon or thereafter ; or

(b) to have committed an offence between two dates falling within such a period,

and the offence would be one against a provision in Part IV of this Act if it had been in operation at all material times, he may be proceeded against as if this Act had so been in operation.

4. Any officer who immediately before the date upon which this Act comes into operation was authorised to recruit or attest ratings shall, without prejudice to any subsequent withdrawal of the authorisation, be deemed without further authorisation a recruiting officer for the purposes of Part III of this Act.

5. Any document made before the date upon which this Act comes into operation which would have been admissible in evidence under the provision of the old Act, or those provisions as applied by any other enactment, shall be admissible to the like extent and in the like proceedings notwithstanding that the old Act has ceased to be in operation.

6. Any forfeiture of, or deduction from, pay having effect under the old Act immediately before the date upon which this Act comes into operation shall continue to have effect notwithstanding the repeal of the old Act.

## FOURTH SCHEDULE

*Enactments Repealed*

<i>Chapter or number</i>	<i>Short title</i>	<i>Extent of repeal</i>
1960 No. 9	The Royal Nigerian Navy Act, 1960	The whole Act
No. 31 of 1959	Nigerian Navy (Change of Title) Act, 1959.	The whole Act
Cap. 131	Nigeria Naval Defence Force Act.	The whole Act.

L.N. 42 of 1964

CUSTOMS TARIFF ACT, 1958  
(No. 60 OF 1958)

Customs Tariff (Duties and Exemptions) (No. 4) Order, 1964

Commencement : 9th March, 1964

In exercise of the powers conferred by subsection (1) of section 6 of the Customs Tariff Act, 1958, the President has made the following Order—

1. This Order may be cited as the Customs Tariff (Duties and Exemptions) (No. 4) Order, 1964, and shall apply throughout the Federation.

2. The Second Schedule to the Customs Tariff Act, 1958 (which relates to exemptions from import duties of Customs) as the same was replaced by the Customs Tariff (Duties and Exemptions) Order, 1959, is amended by the addition after item 33 of the following new item—

“33A. LEATHER AND TEXTILE MATERIALS imported for the manufacture of shoes by a manufacturer approved in that behalf by the Minister”.

MADE at Lagos this 6th day of April, 1964.

R. C. ONYEJEPU,  
*Acting Deputy Secretary to  
the Council of Ministers*

Citation  
and extent.

Amendment  
of Second  
Schedule to  
No. 60 of  
1958.

L.N. 84 of  
1959.

EXPLANATORY NOTE

This Order exempts from duty leather and textile materials used for the manufacture of shoes imported by an approved manufacturer.

F11021/S.305

L.N. 43 of 1964

CUSTOMS TARIFF ACT, 1958  
(No. 60 OF 1958)

Customs Tariff (Duties and Exemptions) (No. 5) Order, 1964

Commencement : 7th April, 1964

In exercise of the powers conferred by subsection (1) of section 6 of the Customs Tariff Act, 1958, the President has made the following Order—

1. This Order may be cited as the Customs Tariff (Duties and Exemptions) (No. 5) Order, 1964, and shall apply throughout the Federation.

2. The First Schedule to the Customs Tariff Act, 1958 (which relates to the import duties of Customs) as the same was replaced by the Customs Tariff (Duties and Exemptions) Order, 1962 is amended by the addition after item 50 of the following item—

“50A. SEWING MACHINE PARTS and hardware items imported for use in the assembly of sewing machines and sewing machine cabinet respectively by a manufacturer approved in that behalf by the Minister . . . . *ad valorem 10 per centum*”

MADE at Lagos this 6th day of April, 1964.

R. C. ONYEJEPU,  
*Acting Deputy Secretary to  
the Council of Ministers*

Citation  
and extent.

Amendment  
of First  
Schedule to  
L.N. 60 of  
1958.  
L.N. 25 of  
1962.

EXPLANATORY NOTE

This Order imposes an *ad valorem* duty of 10 per cent on sewing machine parts and hardware items used for the assembly of sewing machines and sewing machine cabinets and imported by an approved manufacturer.

F11021/S.351



L.N. 47 of 1964

CUSTOMS AND EXCISE MANAGEMENT ACT, 1958

(1958, No. 55)

Open General Import Licence (Netherlands) No. 2 of 1964

Commencement : 16th April, 1964

In exercise of the powers conferred by Section 4 of the Imports Prohibition Order, 1959, the Import Licensing Authority has granted the following Open General Licence—

- 1.—(1) This licence may be cited as the Open General Import Licence (Netherlands) No. 2 of 1964. Citation and application.
- (2) This licence shall be of Federal application. General licence.
2. Subject to the conditions specified in this licence, the importation from the Netherlands of goods of any kind with the exception of the goods set out in the Schedule hereto is hereby authorised. Conditions.
3. This licence is granted subject to the following conditions—
  - (i) that the goods shall be imported through a customs port or other place permitted by the Board of Customs and Excise under section 12 (4) of the Act, a customs airport or a customs station or by post ; L.N. 71 of 1959.
  - (ii) that the goods shall be imported in accordance with the provisions of the Importation and Exportation by Air Regulations, 1959, the Importation and Exportation by Post Regulations, 1959, the Importation and Exportation by Sea Regulations, 1959, or the Importation and Exportation by Land and Inland Waters Regulations, 1959, whichever is applicable ; L.N. 72 of 1959.
  - (iii) that a specific import licence is required for the importation of onions which are excepted from this licence provided—
    - (a) that the onions originate from the North East Polder Region of the Netherlands L.N. 73 of 1959.
    - (b) that the importer shall produce, at the time of importation a phytosanitary certificate showing that the onions were grown in the North East Polder Region of the Netherlands in such form as the Board of Customs and Excise may from time to time approve. L.N. 75 of 1959.
4. Nothing in this licence shall be deemed to authorise the importation of any goods the importation of which is prohibited or restricted by any written law. Saving.

SCHEDULE

GOODS EXCEPTED FROM THIS LICENCE

Description	Import Group	List No. Item
1. Onions .. .. .	054	89
2. Petroleum products .. .. .	313	All
(a) Gold Chloride .. .. .	511	XX9
(b) Jewellery of gold and goldsmith's wares .. .. .	673	010
(c) Gold watches .. .. .	864	XX1
(d) Gold clocks .. .. .	864	XX2

## SCHEDULE—continued

Description	Import Group	List No. Item
(e) Gold watch cases .. .. .	864	XX9
(f) Articles manufactured wholly or mainly of gold not elsewhere specified .. .. .	899	XX0
(g) Gold coin and gold bullion, unrefined gold and partly worked gold .. .. .	XX1	000
4. Cement .. .. .	661	20
5. Tin Ore .. .. .	283	60
6. Zirconium .. .. .	698	50
7. Slag resulting from the processing of Tin .. .. .	698	90
8. Wheat and spelt (including meslin) unmilled .. .. .	041	010
9. Meal and flour of wheat and spelt (including meslin) .. .. .	046	010
10. Sugar (beet and cane refined) .. .. .	061	020
11. Blanket (Cotton) .. .. .	656	62
12. Enamelware (household) .. .. .	697	24
13. Meat and Poultry .. .. .	012	10
	013	01
	023	00
14. Butter .. .. .		
15. The following kinds of produce, except for such produce imported by way of petty or barter trade, accepted as such by the Board of Customs and Excise :—		
(1) Bennisseed .. .. .	221	00
(2) Raw cocoa beans .. .. .	072	00
(3) Raw cotton .. .. .	263	00
(4) Cotton linters .. .. .	263	00
(5) Cotton seed .. .. .	221	00
(6) Cotton seed cake .. .. .	081	00
(7) Cotton seed meal .. .. .	081	00
(8) Cotton seed oil .. .. .	421	90
(9) Groundnuts .. .. .	221	00
(10) Groundnut cake .. .. .	081	00
(11) Groundnut meal .. .. .	081	00
(12) Groundnut oil .. .. .	421	40
(13) Palm kernels .. .. .	221	00
(14) Palm kernel cake .. .. .	081	00
(15) Palm kernel meals .. .. .	081	00
(16) Palm kernel oil .. .. .	422	40
(17) Palm oil .. .. .	422	21-22
(18) Soya beans .. .. .	221	00
(19) Ginger .. .. .	075	22
(20) Grapefruit, Fresh .. .. .	051	90
(21) Grapefruit, Juice .. .. .	053	50
(22) Lemons .. .. .	053	50

J. B. ELUMEZE,  
 Import Licensing Authority,  
 Ministry of Commerce and Industry

Lagos, 16 March, 1964.

## NOTES

*(These notes do not form part of the licence)*

1. Payment for goods imported under this open general licence is subject to the conditions prescribed in Nigerian Exchange Control Notice No. 13 (Third issue).

2. Customs ports mean all ports designated by the President under section 12 of the Customs and Excise Management Ordinance, 1958 (No. 55 of 1958). The approved ports are at present Lagos, Burutu, Warri, Sapele, Degema, Port Harcourt, Calabar and Koko.

3. Customs airports are defined in Article 60 of the Colonial Air Navigation Order, 1955, published as Legal Notice No. 108 of 1955 in the Federation of Nigeria *Official Gazette* No. 45, Vol. 42 of the 6th of October, 1955. Customs airports are at present Calabar, Kano, Lagos (Ikeja) and Maiduguri.

4. Specific import licences are necessary in respect of any of the goods set out in the Schedule to this licence and applications for such licences should be addressed to: The Import Licensing Authority, Federal Ministry of Commerce and Industry, Lagos, Kano, Jos, Port Harcourt, Aba, Calabar, Onitsha, Ibadan, Ondo or Sapele (as appropriate).

5.—(1) Specific import licences for gold bar, gold sheet, wire and grain, and gold bullion will be issued only to gold dealers licensed under the Gold Trading Act (Cap. 76).

(2) Importers applying for specific licences for goods manufactured wholly or mainly of gold, gold clocks, gold watches, gold watch cases, and similar articles manufactured wholly or mainly of gold are required to produce to the Import Licensing Authority details of the total fine gold content of the articles which it is desired to import.

(3) For the purpose of this open general licence, "articles manufactured wholly or mainly of gold" are defined as goods of which the fine gold content is 50 per cent or more of their c.i.f. values.

(4) Before releasing articles containing gold against this open general licence, the Customs authorities may require importers to produce details of the total fine gold content in ounces of such articles.

6. It is not necessary for importers to hold this licence or to produce it to the Customs authorities. Importers are nevertheless advised to retain the Notice for reference as copies are not being distributed. A copy may be seen on application at any Custom House or Post Office.

CS411/ CS370

L.N. 48 of 1964

THE AGRICULTURE (CONTROL OF IMPORTATION) ACT, 1959  
(1959, No. 28)

**Appointed Day Order, 1964**

In exercise of the powers conferred by subsection (1) of section one of the Agriculture (Control of Importation) Act, 1959 and of all other powers enabling him in that behalf, the President has appointed the 31st day of March, 1964 as the date on which the above Act shall come into operation.

DATED at Lagos this 28th day of March, 1964.

R. C. ONYEJEPU,  
*Acting Deputy Secretary to the  
Council of Ministers*

AGR60/3/III/462/53

B 88

L.N. 49 of 1964

THE AIR FORCE ACT, 1964  
(1964, No. 11)

**Appointed Day Order**

In exercise of the powers conferred on me by section 209 (1) of the Air Force Act, 1964, I, Alhaji Muhammadu Ribadu, Minister of Defence hereby appoint the 24th day of February, 1964, being the date of publication of the Act in the Gazette, as the date for the coming into operation of the said Act.

4th March, 1964.

MUHAMMADU RIBADU,  
*Minister of Defence*

L.N. 56 of 1964

CUSTOMS AND EXCISE MANAGEMENT ACT, 1958  
(1958 No. 55)

Open General Import Licence (All Countries) No. 1 of 1964

Commencement : 9th April, 1964

In exercise of the powers conferred by section 4 of the Imports Prohibition Order, 1959, the Import Licensing Authority has granted the following open general licence—

1.—(1) This licence may be cited as the Open General Import Licence (All Countries) No. 1 of 1964.

Citation  
and appli-  
cation.

(2) This licence shall be of Federal application and shall be deemed to have come into operation on 9th April, 1964.

2. Subject to the conditions in this licence, the importation from all countries (with the exception of the countries listed in the First Schedule hereto) of any kind of goods with the exception of goods set in the Second Schedule to this licence is hereby authorised.

General  
licence.

3. This licence is granted subject to the following conditions—

Conditions.

(i) that the goods shall be imported through a customs port or other place permitted by the Board of Customs and Excise under section 12 (4) of the Act, a customs airport or a customs station or by post ;

(ii) that the goods shall be imported in accordance with the provisions of the Importation and Exportation by Air Regulations, 1959, the Importation and Exportation by Post Regulations, 1959, the Importation and Exportation by Sea Regulations, 1959, or the Importation and Exportation by Land and Inland Waters Regulations, 1959, whichever is applicable ;

L.N. 71 of  
1959.  
L.N. 72 of  
1959.  
L.N. 73 of  
1959.  
L.N. 75 of  
1959.

(iii) that the goods originated from the countries not excepted from this licence ;

(iv) that the importer shall produce, at the time of importation, a certificate of origin in respect of the goods in such form as the Board of Customs and Excise may from time to time approve.

4. Nothing in this licence shall be deemed to authorise the importation of any goods the importation of which is prohibited or restricted by any written law.

Savings.

5. Open General Import Licences—

(a) (All Countries) No. 1 of 1959

(b) (Japan) No. 3 of 1959 as amended by L.N. 105 of 1963

(c) (Dollar Area) No. 4 of 1959

(d) (Sugar) No. 6 of 1959

(e) (Wheat and Wheat Flour) No. 1 of 1962

(f) (Hong Kong) No. 1 of 1963,

Validation  
of existing  
licences.

remain valid and operative in respect of the countries to which they relate.

B106

Revocation  
of L.N. 237  
of 1959.  
Replace-  
ment of  
L.N. 44 of  
1964.

6. Open General Import Licence (Scheduled Territories and Easy Currency Countries) No. 2 of 1959 is hereby revoked.

7. This Notice replaces Legal Notice No. 44 of 1964.

### FIRST SCHEDULE

#### COUNTRIES EXCEPTED FROM THIS LICENCE

1. Communist China
2. East Germany
3. Roumania
4. Yugoslavia
5. North Korea
6. South Africa
7. South West Africa
8. North Vietnam
9. Tibet
10. Albania.

### SECOND SCHEDULE

#### GOODS EXCEPTED FROM THIS LICENCE

	<i>Import List No.</i>	
	<i>Group</i>	<i>Item</i>
1. Petroleum products .. .. .	332	All
2. (a) Gold Chloride .. .. .	514	99
(b) Jewellery of gold and goldsmith's wares .. .. .	897	10
(c) Gold watches .. .. .	864	11
(d) Gold clocks .. .. .	864	20
(e) Gold watch cases .. .. .	864	14
(f) Articles manufactured wholly or mainly of gold not elsewhere specified .. .. .	899	99
(g) Gold coin and gold bullion, unrefined gold and partly worked gold .. .. .	1	1.6, 1.1, 1.2, 1.3.
3. Cement .. .. .	661	20
4. Tin ore .. .. .	283	60
5. Zirconium .. .. .	689	50
6. Slag resulting from the processing of Tin .. .. .	698	90
7. Blanket (cotton) .. .. .	656	62
8. Enamelware (household) .. .. .	697	24
9. Meat, fresh, chilled or frozen .. .. .	011	00
10. Bacon and ham .. .. .	012	10
11. Other meat, dried, salted or smoked, not canned .. .. .	012	90
12. Corned Beef .. .. .	013	01
13. Other meat canned and meat preparation canned and not canned .. .. .	013	09
14. Butter .. .. .	023	00

SECOND SCHEDULE—*continued*

15. The following kinds of produce, except for such produce imported by way of petty or barter trade, accepted as such by the Board of Customs and Excise :—

	<i>Import List</i>	<i>No</i>
	<i>Group</i>	<i>Item</i>
(1) Benniseed .. .. .	221	00
(2) Raw cocoa beans .. .. .	072	00
(3) Raw cotton .. .. .	263	00
(4) Cotton linters .. .. .	263	00
(5) Cotton seed .. .. .	221	00
(6) Cotton seed cake .. .. .	081	00
(7) Cotton seed meal .. .. .	081	00
(8) Cotton seed oil .. .. .	421	90
(9) Groundnuts .. .. .	221	00
(10) Groundnut cake .. .. .	081	33
(11) Groundnut meal .. .. .	081	00
(12) Groundnut oil .. .. .	421	40
(13) Palm kernels .. .. .	221	30
(14) Palm kernel cake .. .. .	081	00
(15) Palm kernel meals .. .. .	081	00
(16) Palm kernel oil .. .. .	422	40
(17) Palm oil .. .. .	422	21-22
(18) Soya Beans .. .. .	221	40
(19) Ginger .. .. .	075	00
(20) Grapefruit, Fresh .. .. .	051	90
(21) Grapefruit, Juice .. .. .	053	50
(22) Lemons .. .. .	053	50

J. B. ELUMEZE,  
*Import Licensing Authority,*  
*Federal Ministry of Commerce*  
*and Industry*

Lagos, 13th May, 1964.

## NOTES

(These notes do not form part of the licence)

1. Payment for goods imported under this open general licence is subject to the conditions prescribed in Nigerian Exchange Control Notice No. 13 (Third issue).

2. Customs ports mean all ports designated by the President under section 12 of the Customs and Excise Management Act, 1958 (No. 55 of 1958). The approved ports are at present Lagos, Burutu, Warri, Sapele, Degema, Port Harcourt, Calabar and Koko.

3. Customs airports are defined in Article 60 of the Colonial Air Navigation Order, 1955, published as Legal Notice No. 108 of 1955 in the Federation of Nigeria *Official Gazette* No. 45, Vol. 42 of the 6th of October, 1955. Customs airports are at present Calabar, Kano, Lagos (Ikeja) and Maiduguri.

4. Specific import licences are necessary in respect of the countries listed in the First Schedule and for the goods set out in the Second Schedule to this licence. Applications for such licences should be addressed to:—The Import Licensing Authority, Federal Ministry of Commerce and Industry, Lagos, Kano, Port Harcourt, Aba, Calabar, Onitsha, Ibadan, Ondo or Sapele (as appropriate).

5.—(1) Specific import licences for gold bar, gold sheet, wire and grain, and gold bullion will be issued only to gold dealers licensed under the Gold Trading Act (Cap. 76).

(2) Importers applying for specific licences for goods manufactured wholly or mainly of gold, gold clocks, gold watches, gold watch cases, and similar articles manufactured wholly or mainly of gold are required to produce to the Import Licensing Authority details of the total fine gold content of the articles which it is desired to import.

(3) For the purpose of this open general licence "articles manufactured wholly or mainly of gold" are defined as goods of which the fine gold content is 50 per cent or more of their c.i.f. values.

(4) Before releasing articles containing gold against this open general licence the Customs authorities may require importers to produce details of the total fine gold content in ounces of such articles.

6. It is not necessary for importers to hold this licence or to produce it to the Customs authorities. Importers are nevertheless advised to retain the Notice for reference as copies are not being distributed. A copy may be seen on application at any Custom House or Post Office.

CUMULATIVE INDEX TO SUBSIDIARY LEGISLATION  
FROM 1ST JANUARY TO 30TH DECEMBER, 1963

(a)

TABLE I

ALPHABETICAL LIST OF THE ACTS OF 1963

Title	Page
Appropriation Act, 1963	A3
Army Act, 1963	A39
Cinematograph Act, 1963	A35
Commonwealth Citizenship Act, 1963	A7
Constitution of the Federation	A91
Constitution (Transitional Provisions) Act, 1963	A173
Director of Civil Aviation (Transfer of Functions) Act, 1963	A81
Electoral (Transitional Provisions) Act, 1963	A9
Federal Commissions (Privileges and Immunities) Act, 1963	A77
Immigration Act, 1963	A11
Income Tax (Rents) Act, 1963	A175
Judicial, etc., Offices and Appeals by Prosecutors Act, 1963	A63
Medical and Dental Practitioners Act, 1963	A41
Merchant Shipping (Amendment) Act, 1963	A67
Mid-Western Region (Transitional Provisions) Act, 1963	A85
Oaths Act, 1963	A179
Pools Betting Act, 1963	A79
Ports Act, 1963	A73
Produce (Constitutional Amendment) Act, 1963	A1
Supplementary Appropriation (1961-62) Act, 1963	A69
Supplementary Appropriation (1962-63) Act, 1963	A71
Supplementary Appropriation (1963-64) Act, 1963	A83
Tanganyika Republic Act, 1963	A5
APPLICABLE ONLY TO THE FEDERAL TERRITORY	
City of Lagos Act, 1963	D29
Defamation (Amendment) Act, 1963	D1
Fire Service Act, 1963	D3
Lagos Local Government (Amendment) Act, 1963	D23
Riot (Damages) Act, 1963	D25

(b)

TABLE II

No.	Page
CHRONOLOGICAL LIST OF THE ACTS OF 1963	
1. Produce (Constitutional Amendment) Act, 1963	A1
2. Appropriation Act, 1963	A3
3. Tanganyika Republic Act, 1963	A5
4. Commonwealth Citizenship Act, 1963	A7
5. Electoral (Transitional Provisions) Act, 1963	A9
6. Immigration Act, 1963	A11
7. Cinematograph Act, 1963	A35
8. Army Act, 1963	A39
9. Medical and Dental Practitioners Act, 1963	A41
10. Judicial, etc. Offices and Appeals by Prosecutors Act, 1963	A63
11. Merchant Shipping (Amendment) Act, 1963	A67
12. Supplementary Appropriation (1961-62) Act, 1963	A69
13. Supplementary Appropriation (1962-63) Act, 1963	A71
14. Ports Act, 1963	A73
15. Federal Commissions (Privileges and Immunities) Act, 1963	A77
16. Pool Betting Act, 1963	A79
17. Director of Civil Aviation (Transfer of Functions) Act, 1963	A81
18. Supplementary Appropriation (1963-64) Act, 1963	A83
19. Mid-Western Region (Transitional Provisions) Act, 1963	A85
20. Constitution of the Federation	A91
21. Constitution (Transitional Provisions) Act, 1963	A173
22. Income Tax (Rents) Act, 1963	A175
23. Oaths Act, 1963	A179

CUMULATIVE INDEX TO SUBSIDIARY LEGISLATION—*continued*

Title	No. of Legal Notice	Page
Legal Practitioners Qualifications Regulations, 1963 .. .. .	153	B562
Legal Practitioners Qualifications (Amendment) Regulations, 1963 .. .. .	48	B109
Standing Orders of General Council of the Bar, 1963 .. .. .	140	B542
<b>LOCAL LOANS (REGISTERED STOCK AND SECURITIES) ACT</b> (CAP. III)		
Local Loan (Federal Republic of Nigeria First Development Loan, 1970) Directions, 1963 .. .. .	143	B551
Local Loan (Federal Republic of Nigeria First Development Loan, 1978) Directions, 1963 .. .. .	144	B552
Local Loan (Federal Republic of Nigeria First Development Loan, 1988) Directions, 1963 .. .. .	145	B553
Local Loan (Federal Republic of Nigeria First Development Loan, 1984) Directions, 1963 .. .. .	161	B569
<b>MEDICAL AND DENTAL PRACTITIONERS ACT, 1963</b>		
Medical and Dental Practitioners Act (Commencement) Order, 1963 .. .. .	160	B569
<b>MERCHANT SHIPPING ACT, 1962 (1962, No. 30)</b>		
Certificate of Competency (Able seamen) Regulations, 1963 .. .. .	69	B210
Certificate of Competency (Engine-Room) Regulations, 1963 .. .. .	135	B492
Examination for Certificates of Competency (Deck) Regulations, 1963 .. .. .	79	B253
Examination for Certificates of Competency (Deck) Regulations, 1963 Appointed Day Notice .. .. .	123	B447
Merchant Shipping (Accepted Safety Convention Certificates) Order, 1963 .. .. .	137	B537
Merchant Shipping Act (Restricted Commencement) Notice, 1963 .. .. .	112	B410
Merchant Shipping (Carriage of Passengers) (Amendment) Regulations, 1963 .. .. .	7	B55
Merchant Shipping (Carriage of Passengers) Regulations, 1963 .. .. .	133	B478
Merchant Shipping Collision (Ships and Seaplanes on the Waters) Rules, 1963 .. .. .	88	B354
Merchant Shipping (Dangerous Goods) Rules, 1963 .. .. .	59	B134
Merchant Shipping (Distressed Seamen) Rules, 1963 .. .. .	77	B243
Merchant Shipping (Fees) (Amendment) Regulations, 1963 .. .. .	134	B480
Merchant Shipping (Fees) Regulations, 1963 .. .. .	89	B367
Merchant Shipping (Fire Appliances) Rules, 1963 .. .. .	62	B153
Merchant Shipping (Fishing Boat) Regulations, 1963 .. .. .	63	B176
Merchant Shipping (Inland Waters Craft Exemption) Notice, 1963 .. .. .	75	B226
Merchant Shipping (Licensed Ships) Regulation, 1963 .. .. .	38	B80
Merchant Shipping (Licensing and Control of Boats) Regulations, 1963 .. .. .	68	B205
Merchant Shipping (Life-Saving Appliances) Rules, 1963 .. .. .	76	B238
Merchant Shipping (Life-Saving Appliances) Rules, 1963 .. .. .	80	B303
Merchant Shipping (Mining) Regulations, 1963 .. .. .	58	B130
Merchant Shipping (Navigation of Inland Waters) Regulations, 1963 .. .. .	57	B124
Merchant Shipping (Navigational Warnings) Rules, 1963 .. .. .	87	B352
Merchant Shipping (Musters) Rules, 1963 .. .. .	61	B150
Merchant Shipping (Ports Authority Partial Exemption) Notice, 1963 .. .. .	36	B79
Merchant Shipping (Power Driven Small Craft) Regulations, 1963 .. .. .	64	B195
Merchant Shipping (Restricted Commencement) Notice, 1963 .. .. .	37	B80
Merchant Shipping (Ship's Names) Rules, 1963 .. .. .	70	B218
Merchant Shipping (Signals of Distress) Rules, 1963 .. .. .	60	B149
Merchant Shipping (Subsidiary Legislation Transitional Provisions) Order, 1963 .. .. .	40	B83
Merchant Shipping (Transitional Provisions) Order, 1963 .. .. .	56	B122
Merchant Shipping (Validity of Ships Tonnage) Order, 1963 .. .. .	67	B203
Registration of Shipping (Exemption) Notice, 1963 .. .. .	115	B421
<b>MID-WESTERN REGION ACT, 1962 (1962, No. 6)</b>		
Appointed Day Order .. .. .	96	B397
Education (Amendment) Order, 1963 .. .. .	131	B476
Public Prosecutions (Control) Order, 1963 .. .. .	129	B473
Statutory Corporations (Revesting of Functions) Order, 1963 .. .. .	130	B474

CUMULATIVE INDEX TO SUBSIDIARY LEGISLATION—continued

Title	No. of Legal Notice	Page
<b>MID-WESTERN REGION (TRANSITIONAL PROVISIONS) ACT, 1963</b>		
<b>INTERPRETATION LAW (CAP. 51)</b> .. .. .		
<b>LOCAL GOVERNMENT LAW (CAP. 68)</b>		
Akugbe Iyekuselu and Iyekovia District Councils (Default) (Revocation) Order, 1963 .. .. .	147	B557
Akugbe, Iyekuselu and Iyekovia District Councils (Dissolution) Order, 1963 .. .. .	148	B557
Chiefs Law (Cap. 19) .. .. .	158	B567
<b>MINERAL OILS ACT (CHAPTER 120)</b>		
The Mineral Oils (Safety) Regulations, 1963 .. .. .	45	B92
<b>MINERALS ACT (CHAPTER 121)</b>		
Delegation of Powers (Eastern Nigeria) Notice, 1963 .. .. .	109	B407
Delegation of Powers (Northern Nigeria) Notice, 1963 .. .. .	8	B55
Minerals (Amendment) Regulations, 1963 .. .. .	103	B401
Minerals (Amendment) (No.2) Regulations, 1963 .. .. .	128	B470
Minerals (Safe Mining) (Amendment) Regulations, 1963 .. .. .	10	B57
Prospecting (Areas and Minerals) Prohibition (Amendment) Declaration, 1963 .. .. .	11	B58
Prospecting (Areas and Minerals) Prohibition (Amendment) (No. 2) Declaration, 1963 .. .. .	104	B402
Prospecting (Areas and Minerals) Prohibition (Amendment) (No. 3) Declaration, 1963 .. .. .	139	B541
Prospecting (Areas and Minerals) Prohibition (Amendment) (No. 4) Declaration, 1963 .. .. .	81	B345
<b>MINISTERS' STATUTORY POWERS AND DUTIES (MISCELLANEOUS PROVISIONS) ACT (CHAPTER 122)</b>		
Crown Lands and Land Registration Acts (Delegation) Notice, 1963 .. .. .	18	B68
Delegation of Powers Notice, 1963 .. .. .	142	B549
<b>MONEYLENDERS ACT (CHAPTER 124)</b>		
Commonwealth Development Corporation (Exemption) Order, 1963 .. .. .	102	B401
Commonwealth Development Finance Company Limited (Exemption) Order, 1963 .. .. .	54	B121
Independence Finance Limited (Exemption) Order, 1963 .. .. .	21	B70
<b>NATIONAL PROVIDENT FUND ACT, 1961 (1961, No. 20)</b>		
National Provident Fund (Appointed Day) (Amendment) Order, 1963 .. .. .	47	B107
National Provident Fund (Appointed Day) (Amendment) (No. 2) Order, 1963 .. .. .	127	B469
<b>NIGERIAN RAILWAY CORPORATION ACT (Chapter 139)</b>		
Railway (Amendment No. 1) Bye-Law, 1963 .. .. .	157	B567
<b>NOTARIES PUBLIC ACT (CAP. 141)</b>		
Notaries Fees of Office Order, 1963 .. .. .	159	B568
<b>PENSIONS ACT (CAP. 147)</b>		
Pensions (Amendment) Regulations, 1963 .. .. .	29	B75
<b>PERSONAL INCOME TAX (LAGOS) ACT, 1961 (1961, No. 23)</b>		
Personal Income Tax (Exemption) (G. W. Keep) Order, 1963 .. .. .	74	B225
<b>POOL BETTING ACT, 1963 (1963, No. 16)</b>		
Appointed Day Notice .. .. .	74	B225

CUMULATIVE INDEX TO SUBSIDIARY LEGISLATION—continued

Title	No. of Legal Notice	Page
<b>PORTS ACT (CHAPTER 155)</b>		
Nigerian Ports Authority (Pilotage) (Amendment) Regulations, 1963	..	34
Nigerian Ports Authority (Pilotage Districts) (Amendment) Order, 1963	..	31
Ports (Carbide of Calcium) Regulations, 1963	..	15
<b>PRISONS ACT, 1960 (No. 41 of 1960)</b>		
Notice of Consent .. .. .	..	52
<b>PRODUCE (CONSTITUTIONAL AMENDMENT) ACT, 1963 (1963, No. 1)</b>		
Produce (Constitutional Amendment) Act (Commencement) Order, 1963	162	B571
<b>PUBLIC ORDER (LAGOS) ACT, (CAP. 169)</b>		
Public Order (Lagos) (No. 1) Order, 1963	..	5
Public Order (Lagos) (No. 2) Order, 1963	..	39
Public Order (Lagos) (No. 3) Order, 1963	..	..
Public Order (Lagos) (No. 4) Order, 1963	..	50
Public Order (Lagos) (No. 5) Order, 1963	..	84
Public Order (Lagos) (No. 6) Order, 1963	..	116
	..	146
<b>REGISTRATION OF TITLES ACT (CHAPTER 181)</b>		
Registration of Titles (Application) (No. 3) Order, 1963	..	19
<b>ROAD TRAFFIC ACT (CAP. 184)</b>		
Road Traffic (Control of Traffic) (Lagos) Order, 1963	..	117
<b>SAVINGS BONDS AND CERTIFICATE ACT, 1962 (1962 No. 18)</b>		
National Premium Bonds Regulations, 1963	..	125
Saving Certificates Regulations, 1963	..	126
<b>SHIPPING AND NAVIGATION ACT (CHAPTER 190)</b>		
Certificate of Competency (Approved Engineering Works) (Amendment) Notice, 1963	..	22
Navigation of Inland Waters Regulations, 1963	..	13
<b>TIN ACT 1962 (1962, No. 25)</b>		
Appointed Day Notice .. .. .	..	14
Tin (Research Levy) Regulations, 1963	..	27
<b>UNIVERSITY COLLEGE HOSPITAL ACT (CHAPTER 205)</b>		
University College Hospital (Hospital Fees) (Amendment) Regulations, 1963	12	B62
<b>UNIVERSITY OF IBADAN ACT, 1962 (1962, No. 37)</b>		
University of Ibadan Act (Commencement) Order, 1963	..	124
<b>WEST AFRICAN COCOA RESEARCH INSTITUTE (NIGERIAN STATUS)</b>		
Act, 1950 (No. 6 of 1950)	..	149
Pensionable Offices (West African Cocoa Research Institute) Order, 1963	..	149

L.N. 57 of 1964

BILLS OF EXCHANGE ACT, 1964  
(1964, No. 20)

Bills of Exchange Act (Commencement) Order, 1964

Commencement : 1st June, 1964

In exercise of the powers conferred on me by subsection (2) of section 5 of the Bills of Exchange Act, 1964 and of all other powers enabling me in that behalf, I hereby make the following Order—

1. The Bills of Exchange Act, 1964 shall come into force on the first day of June, 1964.
2. This Order may be cited as the Bills of Exchange (Commencement) Order, 1964.

Commence-  
ment.

Citation.

MADE this 28th day of May, 1964.

F. S. OKOTIE-EBOH,  
*Minister of Finance*

L.N. 58 of 1964

COMPANIES INCOME TAX ACT, 1961  
(1961, No. 22)

Companies Income Tax (Authorised Deductions)  
(Nigerian Industrial Development Bank) Rules, 1964

Commencement : 1st April, 1964

In exercise of the powers conferred by section 27 (h) of the Companies Income Tax Act, 1961, and of all other powers enabling me in that behalf, I hereby make the following rules—

1. These rules may be cited as the Companies Income Tax (Authorised Deductions) (Nigerian Industrial Development Bank) Rules, 1964, and shall be deemed to have come into effect from first day of April, 1964.

Citation and  
commence-  
ment.

2. In these Rules :

“the Company” means the Nigerian Industrial Development Bank Limited.

Definitions.

3. For the purpose of ascertaining the profits or loss of the Nigerian Industrial Development Bank Limited under the Companies Income Tax Act, 1961, for any period (being the appropriate period for computation of such profits or loss for a year of assessment) there shall be deducted any amount transferred by the Company into any reserve funds of the Company : Provided, however, that the total deduction to be allowed under these rules for all such periods shall not exceed the amount of two million pounds (which amount is equal to an amount granted to the Company by the Government of the Federation under a loan Agreement dated the twenty-second day of January, 1964).

Deductions  
allowed.

MADE at Lagos this 18th day of May, 1964.

F. S. OKOTIE-EBOH,  
*Minister of Finance*

EXPLANATORY NOTE

These rules make provisions for the income tax allowances authorised to be made in respect of payments made by the Company into its reserve funds. The total tax allowances to be made under these rules shall not exceed an amount of two million pounds.

L.N. 59 of 1964

ANTIQUITIES ACT (CHAPTER 12)  
**Antiquities (Monuments) Declaration Notice, 1964**

*Commencement : 28th May, 1964*

WHEREAS the Antiquities Commission has submitted an application in accordance with subsection (4) of section 14 of the Antiquities Act (hereinafter referred to as the Act) for the declaration as monuments of the Antiquities set forth in the Schedule hereto :

AND WHEREAS the application has been considered by the President :

NOW THEREFORE, in exercise of the powers conferred by subsection (5) of section 14 of the Antiquities Act the President hereby gives the following notice—

Citation.

1. This notice may be cited as the Antiquities (Monuments) Declaration Notice, 1964.

Declaration of Monuments.

2. The antiquities set forth in the schedule to this notice are declared to be monuments.

Revocation.

3. The Antiquities (Monuments) Declaration Notice, 1961, is hereby revoked.

---

SCHEDULE

1. The carved stone figures between Maghabe and Alok villages in Ogoja Province of Eastern Nigeria.

2. The house and compound of Chief Okoroji situated in Arochuku, Calabar Province of Eastern Nigeria.

3. The Petroglyphs in Igbara Oke, 17 miles from Akure in Western Nigeria.

4. The cave containing rock paintings at Shadawanka near Bauchi, Northern Nigeria, and the land within a radius of one thousand feet of the paintings.

5. The rock of the stone figures containing carvings of two shelter stones at Ofaro in Ilorin Province of Northern Nigeria.

6. The house and compound known as Obu's House at Elu Ohafia in Bende Division, Eastern Nigeria.

7. The Rock at Ochu Kalu, Ndi Okereke Abam in Bende Division of Eastern Nigeria.

8. The building of the Ndi Ezera Clan known as "Omo Ukwu" at Ohafia in the Bende Division of Eastern Nigeria.

MADE at Lagos this 16th day of May, 1964.

I. A. WEMAMBU,  
*Deputy Secretary to the  
 Council of Ministers*

## QUEEN'S COUNSEL (ABOLITION) ACT, 1964



1964, No. 12

AN ACT TO ABOLISH THE RANK OF QUEEN'S COUNSEL ; AND FOR CONNECTED PURPOSES.

[1st May, 1964]

Commence-  
ment.

BE IT ENACTED by the Legislature of the Federation of Nigeria in this present Parliament assembled and by the authority of the same as follows :—

1.—(1) Any person upon whom there has been conferred the rank of counsel to Her Majesty as respects Nigeria shall cease to hold that rank on the commencement of this Act.

Abolition  
of rank of  
Q.C.

(2) Accordingly, the Legal Practitioners Act, 1962, shall be amended as follows :—

1962, No. 33

(a) the following provisions (which relate to the rank aforesaid) shall be omitted, that is to say—

in section two, subsection (2) ;

in section ten, subsection (6) ;

in the First Schedule, the words from the first "in" to "thereafter" in paragraph 2 ; paragraph 3 ; the words "not of counsel to Her Majesty" in paragraph 6 ; and the words "letters patent" ; and

(b) in subsection (2) of section four (which relates to practising fees) for the words "counsel to Her Majesty" there shall be substituted the words "ten or more years standing as a legal practitioner at the beginning of that year," and for the words "five years or more" there shall be substituted the words "more than five and less than ten years" ;

but no person shall, by virtue of paragraph (b) of this subsection, be entitled to a refund of any part of, or required to pay any sum in addition to, the practising fee previously paid by him in respect of the year nineteen hundred and sixty-four in pursuance of section four of the Act aforesaid.

2. This Act may be cited as the Queen's Counsel (Abolition) Act, 1964, and shall apply throughout the Federation.

Short title  
and extent.



## PRESIDENTIAL PROCEEDINGS ACT, 1964



## ARRANGEMENTS OF SECTIONS

<i>Section</i>	
	<i>Declaration of election of President, etc.</i>
<i>Joint meetings of Houses of Parliament</i>	6. Declaration and evidence of election.
1. Procedure at certain joint meetings of Houses of Parliament.	<i>Investigation of conduct of President</i>
<i>Presidential ballots, etc.</i>	7. Establishment and attendance at meetings of investigating committee.
2. Arrangements connected with ballots.	8. Powers and procedure of committee.
3. Voting.	9. Report to Parliament.
4. Counting of votes, etc.	<i>Supplemental</i>
5. Application of ss. 2 to 4 to ancillary ballots.	10. Short title, extent and interpretation.

## 1964, No. 13

AN ACT TO MAKE SUPPLEMENTARY PROVISION FOR THE PURPOSES OF CHAPTER IV OF THE CONSTITUTION OF THE FEDERATION AS RESPECTS THE ELECTION AND REMOVAL OF THE PRESIDENT OF THE REPUBLIC ; AND FOR PURPOSES CONNECTED THEREWITH.

[1st May, 1964]

Commencement.

BE IT ENACTED by the Legislature of the Federation of Nigeria in this present Parliament assembled and by the authority of the same as follows :—

*Joint meetings of Houses of Parliament*

1.—(1) At any joint meeting of both Houses of Parliament held in pursuance of Chapter IV of the Constitution of the Federation (which among other things provides for the election and removal of the President) the following person shall preside, that is to say—

(a) the President of the Senate ;

Procedure at certain joint meetings of Houses of Parliament.

- ( b ) in his absence, the Speaker of the House of Representatives ;
- ( c ) in their absence, the Deputy President of the Senate ;
- ( d ) in the absence of the persons aforesaid, the Deputy Speaker of the House of Representatives ;

and while none of those persons is present, such member of either House as the Prime Minister may designate from time to time shall preside at the joint meeting.

(2) The President of the Senate and the Speaker of the House of Representatives, acting jointly, may make rules regulating, subject to the provisions of the said Chapter IV and this Act, the conduct of joint meetings ; and except so far as it is otherwise provided by rules made in pursuance of this subsection, the Standing Orders of the House of Representatives which on the twelfth day of December, 1962, were ordered by that House to be printed shall, subject as aforesaid, apply with the necessary modifications to joint meetings as they apply to meetings of that House.

(3) Any question arising at a joint meeting as to the application or interpretation of provisions of the rules or standing orders aforesaid shall be determined by the person presiding at the joint meeting when the question arises ; and any question arising at a joint meeting which in the opinion of that person is not regulated by those provisions shall be determined by him.

#### *Presidential ballots, etc.*

2.—(1) It shall be the duty of the President of the Senate to make arrangements for securing that, when a presidential ballot is ordered, there are available for the purposes of the ballot—

Arrange-  
ments  
connected  
with  
ballots.

- ( a ) a list of the persons entitled to vote at the relevant election meeting ;
- ( b ) five hundred ballot papers capable of being folded and bearing on their reverse sides consecutive serial numbers only, each of which is attached to a counterfoil bearing only the same number as the ballot paper to which it is attached ;
- ( c ) an instrument for affixing the special mark mentioned in subsection (2) of the next following section ;
- ( d ) such number of compartments (not being less than twelve) at the place where the relevant election meeting is held as he considers appropriate for securing that each person voting in the ballot is able to mark his ballot paper screened from observation and that the ballot is speedily concluded ; and
- ( e ) a single ballot box.

(2) The person by whom a presidential ballot is ordered shall specify the premises to be used for the purposes of the ballot and shall secure—

- ( a ) that the premises are adequate to accommodate at the same time all the persons entitled to vote at the relevant election meeting and such officials as he may designate to assist at the ballot ;

(b) that no person other than the persons so entitled and the officials aforesaid is admitted to those premises after the ballot is ordered ;

(c) that every person so entitled (other than a witness designated in pursuance of paragraph (e) of this subsection) leaves those premises forthwith after casting his vote and is not thereafter admitted to those premises before the ballot is declared closed ;

(d) that no person so entitled who is not already on those premises is admitted to the premises after the expiration of one hour from the time when the ballot was ordered and before the ballot is declared closed ; and

(e) that, subject to subsection (4) of this section, the compartments, ballot box and unused ballot papers aforesaid allocated to the ballot are, throughout the period beginning with the ordering of the ballot and ending with the declaration of its result, within the immediate view of the following persons, that is to say—

(i) one member of each House of Parliament designated for the purposes of the ballot by the Prime Minister ; and

(ii) one member of either House of Parliament designated for the purposes of the ballot by each candidate in the ballot respectively.

(3) A designation in pursuance of paragraph (e) of the last foregoing subsection shall be made by notice in writing served on the person who ordered the ballot in question ; and in relation to that ballot the persons designated in pursuance of that paragraph by the Prime Minister are hereafter in this Act referred to as “the official witnesses” and a person so designated by a candidate is hereafter in this Act referred to as a “candidate’s witness”.

(4) If the power of designation conferred on a particular candidate by sub-paragraph (ii) of the said paragraph (e) is not exercised by him before the expiration of the period of five minutes beginning with the time when the relevant ballot is ordered, that power shall not be exercised by him in relation to that ballot ; but nothing in the foregoing provisions of this section shall be construed as preventing an official witness or a candidate’s witness from complying with the provisions of subsection (3) of the next following section for the purpose of voting in a presidential ballot.

3.—(1) Each ballot paper for use in a presidential ballot shall, without prejudice to the requirements of the next following subsection, bear on its face only the names of the persons who are candidates for election in the ballot. Voting.

(2) When a presidential ballot is ordered, the person who ordered it shall forthwith determine what special mark shall be affixed to ballot papers and counterfoils to be used in the ballot, and the mark shall—

(a) be such as will identify the papers and counterfoils as valid only for that particular ballot ; and

(b) be affixed by embossing or perforating it on the paper and its counterfoil immediately before the paper is detached from its counterfoil and handed to the voter by whom it is to be used ;

and the ballot paper issued to each voter shall be taken at random from among the remaining ballot papers allocated to the ballot and not in such a sequence or other manner as to permit the identification of the voter to whom it was issued.

(3) A person voting in a presidential ballot shall cast his vote by—

(a) obtaining in person a ballot paper marked with the appropriate special mark from the officer instructed by the person who ordered the ballot to issue the ballot papers for that ballot ; and

(b) immediately thereafter entering one of the compartments provided in pursuance of the last foregoing section so that he is screened from view and there—

(i) marking a cross on the paper at the end of the name of a single candidate for whom he casts his vote ; and

(ii) folding the paper so that the face of it is not visible ; and

(c) immediately thereafter and without unfolding the paper, showing the special mark on it to the official from whom he received the paper and placing the paper in the ballot box indicated by that official.

(4) A person to whom a ballot paper is issued in pursuance of the last foregoing subsection shall, subject to the following provisions of this subsection, not be entitled to dispose of the paper otherwise than in the manner provided by that subsection ; but if such a person marks his ballot paper in a manner other than that which he intends, he may, before placing the paper in the ballot box in accordance with the last foregoing subsection but not thereafter, return the paper to the official from whom he received it, and the official shall thereupon—

(a) issue him with a further ballot paper for that ballot ; and

(b) burn the returned paper and record on its counterfoil the fact that it has been burnt and the number of the further paper.

(5) Not more than two further ballot papers shall be issued in pursuance of subsection (4) of this section to the same person for the purposes of the same presidential ballot ; and where the number of ballot papers provided for a particular ballot in pursuance of paragraph (b) of subsection (1) of the last foregoing section is insufficient to enable effect to be given to the foregoing provisions of this section, the person by whom the ballot was ordered shall make such arrangements as he considers appropriate for furnishing such additional similar ballot papers as may be necessary for meeting the deficiency.

(6) When a ballot paper or further ballot paper is issued to any person in pursuance of this section, the official who issued the paper shall record against the name of that person on the list of persons entitled to vote at the relevant election meeting the fact that a ballot paper or further paper has been issued to him ; but no record shall be made, either on the list or elsewhere, of the number of any ballot paper issued to a particular person.

(7) When, at any time after the expiration of one hour from the time when a presidential ballot was ordered, it appears to the person who ordered it that all persons eligible to vote in the ballot and present in the premises specified in pursuance of subsection (2) of the last

foregoing section have had a reasonable opportunity of casting their votes, he shall declare the ballot to be closed; and no vote shall be cast in the ballot after the declaration is made.

4.—(1) When a presidential ballot is declared closed, the ballot papers used in the ballot shall forthwith be scrutinised, and the votes entered on the papers in favour of each candidate respectively counted and recorded, by the official witnesses and the person who ordered the ballot acting jointly (hereafter in this section referred to as "the scrutineers") and shall be so scrutinised, counted and recorded in the premises specified in pursuance of subsection (2) of section two of this Act and in the immediate view of the candidates' witnesses.

Counting of votes, etc.

(2) In counting and recording the votes aforesaid there shall be disregarded any ballot paper which, in the opinion of the scrutineers or any two of them,—

- (a) does not bear the appropriate special mark; or
- (b) is not marked with a vote; or
- (c) is marked with a vote in such manner as not to indicate a particular candidate as the sole candidate for whom the vote is cast; or
- (d) is marked in such a manner as to enable the voter to be identified; or
- (e) bears the same serial number as any other ballot paper which purports to have been used in the ballot and which does not fall to be disregarded in pursuance of any of the foregoing paragraphs of this subsection;

but, subject to the foregoing provisions of this subsection, the fact that a ballot paper is marked elsewhere than at the proper place or otherwise than by means of a cross shall not entitle the scrutineers to disregard the paper if they or any two of them are of opinion that the paper clearly indicates an intention to vote for a particular candidate.

(3) On completing the recording of the votes cast in a presidential ballot the scrutineers shall exhibit the record to the candidates' witnesses; and if—

- (a) in the opinion of the scrutineers or any two of them a recount of the votes is appropriate; or
- (b) any candidate's witness demands a recount of the votes and in the opinion of the scrutineers or any two of them the demand is reasonable,

the scrutineers shall forthwith order a recount of the votes and proceed in accordance with subsections (1) and (2) of this section as upon a declaration that the ballot is closed.

(4) Where a record is exhibited to the candidates' witnesses in pursuance of the last foregoing subsection and no recount is ordered, the person who ordered the ballot shall forthwith announce the result of the ballot to the joint meeting.

5. The provisions of sections two to four of this Act shall, subject to the provisions of subsection (9) of section thirty-five of the Constitution of the Federation, apply to a ballot held in pursuance of subsection (8) of that section (which provides for the elimination of one of two candidates in a presidential ballot where each receives the same number of votes which is less than the number received by a further candidate) as those provisions apply to a presidential ballot.

Application of ss.2 to 4 to ancillary ballots.

*Declaration of election of President, etc.*

Declaration  
and  
evidence  
of election.

6.—(1) Where the result of a presidential ballot is that a candidate is elected as the President of the Republic, the person presiding at the joint meeting when the result is announced shall forthwith—

(a) declare that candidate to be so elected ; and

(b) execute in duplicate in the presence of the official witnesses and in accordance with subsection (11) of section thirty-five of the Constitution of the Federation (which provides for proof of the election of a person as the President) such an instrument as is mentioned in that subsection.

(2) Each of the official witnesses shall sign his name upon the instruments aforesaid in witness of their execution, and one of those instruments shall be deposited and preserved in the records of the Senate and the other in the records of the House of Representatives ; and rules made by the President of the Senate and the Speaker of the House of Representatives, acting jointly, may provide for the issue of authenticated copies of the instruments.

*Investigation of conduct of President*

Establishment  
and  
attendance  
at meetings  
of  
investiga-  
ting  
committee.

7.—(1) Subject to the next following subsection, the committee mentioned in subsection (5) of section thirty-eight of the Constitution of the Federation (which provides for a committee of members of Parliament to investigate and report to Parliament on the conduct of the President of the Republic where a motion for the investigation is passed by a joint meeting) shall consist of—

(a) four persons nominated in writing by the Prime Minister, of whom two shall be Senators and the others shall be members of the House of Representatives and of whom one shall be designated by the Prime Minister as the chairman of the committee ; and

(b) four Senators nominated by resolution of the Senate ; and

(c) four members of the House of Representatives nominated by resolution of that House.

(2) The powers of nomination conferred by paragraphs (b) and (c) of the foregoing subsection shall, without prejudice to any nomination made in the exercise of those powers during the period of four days beginning with the date of the passing of the motion in consequence of which the committee is set up, not be exercisable as respects the committee after the expiration of that period.

(3) There shall be a legal assessor to the committee, who shall be a judge of the Supreme Court nominated in writing by the Prime Minister.

(4) It shall be the duty of every member of the committee and the legal assessor to be present throughout every meeting of the committee unless he is excused from attendance by the committee on the ground of serious illness ; and a person who—

(a) is so excused ; or

(b) without being so excused is absent from a meeting of the committee,

shall cease to be a member of the committee or its assessor, as the case may be, and shall, in a case falling within paragraph (b) of this subsection, be guilty of contempt of the committee and punishable accordingly.

(5) Where the chairman of the committee or its legal assessor dies or ceases to hold office by virtue of the last foregoing subsection, then—

(a) in the case of the chairman, the Prime Minister shall designate an existing member of the committee (whether or not a person nominated as a member by the Prime Minister) to be its chairman; and

(b) in the case of the legal assessor, the power to nominate a legal assessor shall again be exercised;

but no person shall be nominated as a member of the committee in the place of a person who has ceased to be such a member.

8.—(1) The committee shall, during the period beginning with the date of its first meeting and ending with the date of its dissolution, be a superior court of record.

(2) The committee shall meet at such times and places as the chairman of the committee may determine, and the chairman shall so exercise his powers under this subsection as to secure that the business of the committee is concluded with all reasonable speed and within the period of three months mentioned in subsection (5) of section thirty-eight of the Constitution of the Federation; and every meeting of the committee shall, except so far as the committee otherwise determines, be held in public.

(3) Any question for determination by the committee shall be determined by the votes of a majority of the members of the committee; and in case of an equality of votes the chairman of the committee shall exercise a second or casting vote.

(4) Subject to subsections (2), (3) and (9) of this section, the President of the Senate, the Speaker of the House of Representatives and the Attorney-General of the Federation, acting jointly, may make rules as to the procedure to be followed and the rules of evidence to be observed in proceedings before the committee; and except so far as is otherwise provided by this Act or by rules made in pursuance of this subsection, the rules of procedure to be followed and the rules of evidence to be observed in proceedings before the committee shall, subject to the necessary modifications, be the same as those having effect with respect to proceedings on indictment in the High Court of Lagos.

(5) Any question as to the application or interpretation, in relation to proceedings of the committee, of any such rules as are mentioned in the last foregoing subsection shall be determined by the committee, and the committee shall, before making a determination in pursuance of this subsection, take into consideration the advice of the legal assessor on the question; and where such a determination is, in the opinion of the assessor, not in accordance with his advice, the assessor shall state his opinion and the reasons for it to the committee and the committee shall include in its report to Parliament a statement of the determination and of the advice, opinion and reasons aforesaid.

Powers  
and  
procedure  
of  
committee.

(6) The committee may, if it thinks fit, appoint such legal practitioners as it considers appropriate to assist the committee in the conduct of its proceedings.

(7) No process touching the committee or its proceedings shall issue out of any court except—

(a) at the instance of the committee ; or

(b) for the purpose of securing the attendance of witnesses or the production of evidence in connection with proceedings before the committee ; or

(c) in connection with an alleged offence of perjury committed in connection with such proceedings.

(8) No punishment for contempt of the committee shall be imposed by the committee on any person except with the concurrence of the legal assessor.

(9) Where a new legal assessor is nominated in pursuance of subsection (5) of the last foregoing section then, except so far as the committee otherwise determines with the consent of the person whose conduct is the subject of its proceedings, it shall be the duty of the committee, without prejudice to its power to take again any evidence previously given before the committee, to disregard for the purposes of its report any proceedings before the committee which took place before the nomination of the new assessor.

Report to  
Parliament.

9.—(1) The report of the committee on the conduct of the President of the Republic shall be in writing and the committee shall present the report to Parliament by causing a copy of the report to be served on the Clerk to the Senate.

(2) It shall be the duty of the Clerk to the Senate forthwith to cause a report served on him in pursuance of this section to be printed and a printed copy of it to be made available to each Senator and each member of the House of Representatives respectively.

(3) On the presentation of its report to Parliament, the committee shall stand dissolved.

### *Supplemental*

10.—(1) This Act may be cited as the Presidential Proceedings Act, 1964, and shall apply throughout the Federation.

(2) In this Act—

“candidate’s witness” and “official witnesses” have the meanings assigned to them by subsection (3) of section two of this Act ;

“election meeting” and “presidential ballot” have the same meanings as in section thirty-five of the Constitution of the Federation ; and

“joint meeting” means a joint meeting of both Houses of Parliament held in pursuance of Chapter IV of the Constitution of the Federation.

Short  
title,  
extent and  
interpreta-  
tion.

# DEFENCE INDUSTRIES CORPORATION OF NIGERIA ACT, 1964



## ARRANGEMENT OF SECTIONS

<i>Section</i>		
1. Defence Industries Corporation of Nigeria.		8. Interest of member to be disclosed on any contract.
2. Corporation to act under directions of Minister.		9. Restricted application of Firearms Act.
3. Appointment and powers of general manager.		10. Application of Factories Act.
4. Staff.		11. Taking part in any strike an offence.
5. Operation of ordnance factories.		12. Regulations.
6. Funds of corporation.		13. Interpretation.
7. Accounts and records to be kept.		14. Short title, application and commencement.
		Schedule—Constitution, etc., of the corporation.



## 1964, No. 14

AN ACT TO ESTABLISH A CORPORATION TO OPERATE, MAINTAIN AND CONTROL FACTORIES FOR THE MANUFACTURE, STORAGE AND DISPOSAL OF ORDNANCE AND ANCILLARY STORES AND MATERIEL ; TO PROVIDE FOR ALTERATION IN ANY SUCH MANUFACTURE, STORAGE AND DISPOSAL AT ANY TIME ; AND FOR RELATED MATTERS.

[Section 14 (2)]

Commence-  
ment.

BE IT ENACTED by the Legislature of the Federation of Nigeria in this present Parliament assembled and by the authority of the same as follows :—

1.—(1) On a day to be appointed by order of the Minister in the Gazette (in this Act referred to as "the appointed day") the assets of the Government of the Federation in any land or any building thereon erected or in course of erection as an ordnance factory (as hereafter referred to in this section) and so designated in such order as to sufficiently identify it shall vest in and be operated, maintained and controlled by the corporation hereafter mentioned.

Defence  
Industries  
Corporation  
of Nigeria.

(2) There shall be established with effect from the appointed day, a corporation to be known as the Defence Industries Corporation of Nigeria (in this Act referred to as "the corporation") which shall be a body corporate and be charged with—

(a) the operation, maintenance and control in such place or places in Nigeria as the Minister may require, of factories (in this Act referred to as "ordnance factories") for the manufacture, storage and disposal of ordnance and ancillary stores and materiel intended for or capable of being used by the armed forces and such other forces or persons as the Council of Ministers may authorise, and vested in the corporation under subsection (1) of this section or hereafter erected on land the location of which is approved by the Minister ;

(b) the inspection or testing, as the case may be, of ordnance and materiel ;

(c) such other duties as may be prescribed under this Act.

(3) The provision of the schedule to this Act shall have effect as regards the membership, proceedings and contractual powers of the corporation.

2.—(1) The Minister may for all or any of the purposes of this Act initiate or approve policy ; and accordingly the Minister may give to the corporation directions of a general or special nature as to—

Corporation  
to act  
under  
directions  
of  
Minister.

(a) the manner in which the corporation is to exercise its powers, or

(b) the payment of allowances to members of the corporation,

and it shall be the duty of the corporation to give effect to any such directions.

(2) No policy initiated by the corporation shall be implemented without prior reference to and approval by the Minister, and the Minister may, if he thinks it necessary, consult with the corporation before approving any policy ; but the question whether there was any such consultation or what was decided shall not be inquired into by any court.

Appoint-  
ment and  
powers of  
general  
manager.

3.—(1) The Minister may from time to time appoint a fit person to be general manager of the corporation. The general manager shall be the chief executive officer of the corporation, and as and when directed so to do, he shall give to the corporation such information as to the activities of the corporation as the Minister or the corporation may reasonably require.

(2) The corporation may delegate to the general manager all or any of the powers mentioned in this section; and subject thereto the general manager may authorise programmes and plans for giving effect to policy approved by the Minister or to any direction or recommendation of the corporation as to any ordnance factory in Nigeria or as to staff training therein.

(3) The fact that any such powers have been delegated to the general manager shall not preclude the corporation itself from exercising them in any special case.

(4) The powers mentioned in this section are—

- (a) the executive control over other servants of the corporation,
- (b) the supervision of accounts and records,
- (c) the preparation for approval of sectional programmes and plans necessary to carry into effect approved policy or any directions of the corporation,
- (d) the interpretation of such policy to other servants of the corporation where necessary,
- (e) the making of any staff recommendations to the corporation,
- (f) the establishment of organisational structures and definition of responsibilities.

Staff.

4.—(1) Subject to the provisions of this section, the corporation may appoint such persons as members of its staff as it considers necessary and may approve conditions of service, including provision for the payment of pensions:

Provided that no pension scheme shall be put into operation without the prior approval in writing of the Federal Minister charged with responsibility for pensions.

(2) The secretary of the corporation shall be appointed subject to the approval of the Minister, and shall keep the records and conduct correspondence and perform such other duties of a clerical nature as the corporation may from time to time direct or require.

(3) The general manager and other members of the staff of the corporation shall, unless exempted by the Minister, take such oaths as to secrecy and other matters as the Minister may from time to time direct.

(4) If the Minister deems it expedient that any staff vacancy should be filled by a person holding office in the public service of the federation he shall inform the Federal Minister charged with responsibility for establishments to that effect, and thereafter the public service commission of the federation may fill the vacancy by way of secondment or transfer.

(5) Where any member of the public service is seconded to the staff of the corporation, he shall be notified of the terms and conditions thereof, and any such secondment shall be without prejudice to any pension rights, which, but for the secondment, would still accrue or become due, owing and payable to such public servant. Any person

seconded to such staff may elect to be transferred to the staff, and any previous service in the public service of the federation shall count as service for the purposes of any pension subsequently payable.

(7) Where any member of the public service is transferred to the corporation, his former service with the public service of the federation shall be taken into account when computing any requirements of the Pensions Act, and where the Federal Minister of Pensions approves, the said Minister shall do all things necessary and that Act shall be construed and have effect as if the service with the corporation thereafter of the person so transferred were service with such public service of the federation.

Cap. 147.

5.—(1) The corporation shall operate any ordnance factory under its control on a sound commercial basis and so as to fill the normal defence requirements of the armed forces; and shall plan its activities so far as may be necessary to meet other needs from time to time prescribed by the Council of Ministers.

Operation of ordnance factories.

(2) If there is any surplus capacity in the operation of an ordnance factory, the general manager shall so advise the Minister through the corporation and the Minister with the approval of the Council of Ministers may direct that any such surplus capacity may be adapted where necessary and be used towards meeting the civilian needs of Nigeria.

(3) Where the corporation undertakes the inspection and testing of ordnance and materiel for use by the armed forces, it shall recommend adoption or rejection as the case may be to the Minister, and the Minister shall give any directions necessary in the circumstances.

(4) The corporation may on behalf of any of the governments of Nigeria, test and inspect any substance, material, machine or other thing whatsoever intended for or capable of being used by the armed forces, whether or not it is thereafter so used, or is rejected.

(5) For all or any of the purposes of this section, the corporation may, in its discretion, institute a system of technical standards of classes of materials, structures and machines.

6. The Funds of the corporation shall consist of—

Funds of corporation.

(a) such sum as may be required for the completion of any building erected as an ordnance factory and taken over on the appointed day;

(b) moneys from time to time voted by Parliament,

(c) moneys received from the process of any sale or hire.

7.—(1) The corporation shall keep proper accounts and other records and shall not later than the thirtieth day of September in each year prepare estimates of receipts and expenditure of the corporation for the next ensuing financial year and shall submit the estimates for the approval of the Minister.

Accounts and records to be kept.

(2) If the estimated expenditure approved for a financial year is exceeded without the prior approval in writing of the Minister, members of the corporation shall be liable to a surcharge on salary or allowances as the case may be, at the instigation of the Director of Audit.

(3) Separate accounts shall be kept in relation to moneys received and expended by the corporation in connection with the manufacture, production, sale and letting on hire of any equipment authorised for release under this Act.

(4) The accounts of the corporation shall be audited by auditors to be appointed annually by the corporation with the approval of the

Minister ; and as soon as may be after each audit the corporation shall furnish a copy of the statement of accounts to the Minister together with a copy of any report made by the auditors on that statement or on the accounts of the corporation.

Interest of member to be disclosed on any contract.

8.—(1) A member of the corporation who has any interest in any company or concern with which the corporation proposes to make any contract or any interest in such contract, shall disclose to the corporation the fact of such interest and the nature thereof, and such disclosure shall be recorded in the minutes of the corporation.

(2) A member having any such interest shall take no part in any deliberation or decision of the corporation relating to such contract.

Restricted application of Firearms Act. Cap. 69.

9.—(1) Nothing in the Firearms Act shall be construed to preclude the importation by the corporation of any firearm as therein defined or ammunition, or the manufacture, assembly, repair, or disposal of any such firearm or ammunition in an ordnance factory.

(2) Every ordnance factory under the control of the corporation shall, for the purposes of the Firearms Act be deemed to have been recognised as a public armoury without further authority than this Act ; but firearms and ammunition therein may be held by the corporation for such period as it thinks fit, anything in the Firearms Act to the contrary notwithstanding.

Application of Factories Act. Cap. 66.

10. In the application of the Factories Act, it shall not be necessary to register any ordnance factory ; and the powers of entry and inspection shall be exercisable during the hours of daylight and then only at such time or times as may be convenient to the general manager, after taking into consideration the nature of the work, or the part of the ordnance factory to be inspected.

Taking part in any strike an offence.

11. It shall be an offence punishable on conviction by a fine of not less than fifty pounds or more than one hundred pounds or by imprisonment for a term of one month, or by both, for any person employed by the corporation in any capacity, and whether or not a member of a trade union to engage, or take part, in any strike.

Regulations.

12.—(1) The Minister may make regulations generally for the purposes of this Act.

(2) Notwithstanding the provisions of subsection (1) of this section, the corporation may, with the approval of the Minister, make regulations—

- (a) for prescribing the terms and conditions of service of the general manager and other servants of the corporation ;
- (b) for regulating the procedure in the activities of the corporation other than at meetings ;
- (c) for prescribing danger zones within or outside an ordnance factory.

Interpretation.

13. In this Act unless the context otherwise requires—  
 "armed forces" means the army, navy and air force of Nigeria ;  
 "building" includes fixtures, and any plant, machinery and office furniture supplied or to be supplied under any contract, and whether or not affixed or intended to be affixed to the land ;  
 "the corporation" means the Defence Industries Corporation of Nigeria established under this Act ;  
 "materiel" includes any armament, ammunition and equipment ;  
 "the Minister" means the Federal Minister charged with responsibility for defence ;

“ordnance factory” means any public establishment for the manufacture, storage and disposal of ordnance and ancillary stores and materiel intended for or capable of being used by the armed forces, and includes the manufacture of any other thing that may be approved under this Act.

14.—(1) This Act may be cited as the Defence Industries Corporation of Nigeria Act, 1964 and shall apply throughout the Federation.

Short title,  
application  
and  
commence-  
ment.

(2) This Act shall, as to sections one and six, come into operation on the appointed day which may, in the discretion of the Minister, be the date of its passing; and subject thereto, the provisions of this Act shall commence on a day to be appointed after the passing of this Act, and whether by the same or any further order of the Minister.

## SCHEDULE

### Section 1 (3)

#### *Constitution, etc., of the Corporation*

1.—(1) The corporation shall be a body corporate with perpetual succession and a common seal.

(2) Membership of the corporation shall consist of nine fit persons appointed by the Minister of whom—

(a) the chairman shall be the permanent secretary of the Ministry of Defence,

(b) the general manager who shall be deputy chairman ;  
and the following other members so appointed—

(i) one on the recommendation of the Accountant-General of the Federation,

(ii) one from the Ministry of Commerce and Industry on the recommendation of the Federal Minister responsible therefor,

(iii) one from the army on the recommendation of the army council,

(iv) one from the navy on the recommendation of the navy board,

(v) one from the air force on the recommendation of the air council,

(vi) one from the Nigeria police force on the recommendation of the Inspector-General of Police,

(vii) the chief accountant in the Ministry of Defence.

(3) If the chairman or the deputy chairman is unable to attend, the Minister shall in writing appoint the chairman for any particular meeting.

(4) Subject to the foregoing provisions of this paragraph, where any person appointed by virtue of office or otherwise is absent or unable for any reason to attend meetings he may by writing under his hand addressed to the chairman nominate some other person to attend; and any such nominee shall if approved by the chairman and for the purposes of any meeting of the corporation attended by the nominee, be deemed to be a member of the corporation.

(5) A member shall hold office for such period and on such terms as may be specified in the relevant instrument of appointment, but

if directed in writing by the Minister shall vacate office anything to the contrary in the instrument notwithstanding; and any person so required to vacate his office shall cease to be a member of the corporation.

2.—(1) The first meeting of the corporation shall be convened and held at such place as the Minister may nominate, and any subsequent meeting shall be convened by the chairman.

(2) At any meeting the general manager shall have a deliberative vote, but if at a meeting matters touching or concerning him are being discussed the general manager shall not vote, and if in the chair he shall vacate it in favour of any member appointed for the purpose. For the avoidance of doubt any such temporary chairman may be appointed at the meeting.

(3) The quorum for a meeting shall include the chairman and be three, unless at a meeting matters touching or concerning the general manager are under consideration and he is present, when the quorum shall be four.

(4) Subject to the foregoing provisions of this paragraph, in the case of equality of votes the chairman shall also have a casting vote.

(5) If for any reason the chairman fails to convene a meeting, the Minister may himself convene the meeting.

3.—(1) The corporation may make standing orders for regulating the proceedings of any meeting of the corporation or of any committee of the corporation; but no committee member shall be co-opted from outside the corporation in matters relating to defence.

(2) Where standing orders provide for committees other than of members of the corporation, or comprising partly members thereof and partly persons co-opted for the purpose, they may advise the corporation on matters referred to it by the corporation; but co-opted members shall not be entitled to vote at any meeting they are invited to attend.

4.—(1) The application of the seal of the corporation shall be authenticated by the signature of the chairman or by that of the general manager, as the case may be.

(2) Every document purporting to be an instrument issued by the corporation and to be so sealed or to be signed on behalf of the corporation, shall be received in evidence and be deemed to be an instrument without further proof unless the contrary is shown.

(3) The corporation may sue and be sued in its corporate name and may enter into contracts, and subject to this Act, may engage staff and such technical and other advisers as it deems necessary from time to time. The corporation may also acquire and hold land and any movable property for the purposes of this Act, but no land shall be alienated in any way or be charged as security without the consent in writing of the Minister.

(4) Where the Minister satisfies the Council of Ministers that any land to which the Public Lands Acquisition Act applies is required for the purposes of the corporation and that it has been found impracticable to acquire such land by private treaty or agreement, the President may by order direct that proceedings be taken to acquire such land for the federal government; and any land so acquired may thereafter be vested in the corporation under the authority of this subsection by means of a certificate under the hand and seal of the chief federal land officer.

Cap. 167.

**LAGOS EXECUTIVE DEVELOPMENT  
BOARD (POWERS) ACT, 1964**



**1964, No. 15**

AN ACT TO EXTEND THE POWERS OF THE LAGOS EXECUTIVE DEVELOPMENT BOARD; AND FOR CONNECTED PURPOSES.

[1st May, 1964]

Commence-  
ment.

BE IT ENACTED by the Legislature of the Federation of Nigeria in this present Parliament assembled and by the authority of the same as follows :—

1.—(1) The Lagos Executive Development Board established by the Lagos Town Planning Act shall have, and be deemed always to have had, power to act as the agent of the President of the Republic and any Minister of the government of the Federation, on such terms as may be agreed between the Board and the President or the Minister in question, as respects any matter as respects which the President or the Minister has, either before or after the passing of this Act, requested the Board to act as aforesaid.

Extension  
of powers  
of Board.  
Cap. 95.

(2) References in the foregoing subsection to the President shall be construed, in relation to any period before the first day of October, nineteen hundred and sixty-three, as references to the Governor-General of the Federation.

2. This Act may be cited as the Lagos Executive Development Board (Powers) Act, 1964, and shall apply throughout the Federation.

Short title  
and extent.



**SUPPLEMENTARY APPROPRIATION  
(1963-64) (No. 2) ACT, 1964**



**1964, No. 16**

AN ACT TO AUTHORISE THE ISSUE OUT OF THE CONSOLIDATED REVENUE FUND OF THE SUM OF TWO HUNDRED AND THIRTY THOUSAND, SIX HUNDRED POUNDS FOR THE PURPOSE OF REPLACING ADVANCES FROM THE CONTINGENCIES FUND FOR THE YEAR ENDING ON THE THIRTY-FIRST DAY OF MARCH, ONE THOUSAND, NINE HUNDRED AND SIXTY-FOUR; AND TO APPROPRIATE THAT SUM FOR THE PURPOSES SPECIFIED IN THIS ACT.

[ 1st May, 1964 ]

Commence-  
ment.

BE IT ENACTED by the Legislature of the Federation of Nigeria in this present Parliament assembled and by the authority of the same as follows :—

1. The aggregate amount mentioned in section one of the Appropriation Act, 1963, section one of the Supplementary Appropriation (1963-64) Act, 1963 and in section one of the Supplementary Appropriation (1963-64) Act, 1964 (which together provide for the issue out of the Consolidated Revenue Fund in respect of the year ending on the 31st day of March, 1964, of sums not exceeding in aggregate £58,823,560) shall be increased by two hundred and thirty thousand, six hundred pounds; and the additional amount shall be appropriated for the replacement of advances from the Contingencies Fund.

Issue and  
appropria-  
tion of  
£230,600  
from Con-  
solidated  
Revenue  
Fund for  
Contin-  
gencies  
Fund.  
1963, Nos. 2  
and 18;  
1964, No. 7.

2. This act may be cited as the Supplementary Appropriation (1963-64) (No. 2) Act, 1964, and shall apply throughout the Federation.

Short title  
and  
extent.





ARRANGEMENT OF SECTIONS

*Section*

- |  |   |
|--|---|
| <ol style="list-style-type: none"> <li>1. Additional representation on Advisory Council from new Regions.</li> <li>2. Liability of employer to pay certain moneys into the Fund.</li> <li>3. Member may receive further benefit in certain cases.</li> </ol> | <ol style="list-style-type: none"> <li>4. National Provident Fund Committee and sub-committee.</li> <li>5. Failure to produce certain records an offence.</li> <li>6. Miscellaneous amendments.</li> <li>7. Short title, citation and application.</li> </ol> |
|--|---|

1964, No. 17

AN ACT TO AMEND THE NATIONAL PROVIDENT FUND ACT, 1961.

[ 1st May, 1964 ]

Commencement.

BE IT ENACTED by the Legislature of the Federation of Nigeria in this present Parliament assembled and by the authority of the same as follows :—

1.—(1) If before or after the passing of this Act further Regions are created and the like representation on the Advisory Council as constituted under section eight of the National Provident Fund Act 1961 (in this Act referred to as “the principal Act”) as is accorded to other Regions is desired by any such Region, the Minister may by order in the Gazette amend the Constitution of that Council to the extent necessary to give effect to such desire and the First Schedule to the principal Act shall have effect accordingly, so however that the total membership of the Advisory Council shall not at any one time exceed twenty-five ; and if the membership is increased under this subsection the Minister may, by the same or any other order, fix a quorum for any meeting.

Additional representation on Advisory Council from new Regions.

(2) Where the said First Schedule is amended under the foregoing subsection and persons are appointed to membership, they shall have all the powers of members of the Advisory Council and the provisions of the principal Act as to payment of expenses and allowances of members shall be so construed and have effect.

Liability of employer to pay certain moneys into the Fund.  
1961 No. 20.

2. It is declared for the avoidance of doubt that where by the principal Act an employer is required to deduct a worker's contribution and pay it into the Fund within a prescribed time, the employer shall pay into the Fund at the same time his own contribution as an employer of the worker concerned; and section thirteen of the principal Act (which requires an employer to deduct a worker's contribution for payment into the Fund) shall be construed accordingly.

Member may receive further benefit in certain cases.

3. If a member receives a benefit under the principal Act and at any time thereafter qualifies for a further benefit he shall, to the extent to which he still has moneys in the Fund and notwithstanding anything to the contrary in section twenty-eight of the principal Act (which imposes restrictions on double grant or benefit), be entitled to such further benefit although he may not have again become a contributor.

National Provident Fund Committee and sub-committee.

4.—(1) There shall be a committee to be known as the National Provident Fund Investment Committee (hereafter called "the investment committee") for the control of investment of moneys in the Fund not required for the acquisition of property of any description under the principal Act; and the investment committee shall consist of one member from each Region to be appointed by the Minister on the nomination of the Minister in that Region charged with responsibility for finance, and the following representatives or holders of office appointed by the Minister as Federal territory members that is to say,—

- (a) one fit officer of the Federal Ministry of Finance,
- (b) one fit officer of the Central Bank of Nigeria nominated by the Governor of that Bank, and
- (c) the Director.

(2) Regional members appointed under the foregoing subsection shall hold office for a period of two years, or if appointed by office then during the tenure of such office, but with that reservation they shall be eligible for reappointment; and Federal territory members so appointed shall hold office during the continuance of their employment in the Federal territory, but may be removed from office by the Minister without the necessity for assigning any reason.

(3) The persons who, immediately before the commencement of this Act were members of the investment committee, shall be deemed to have been reappointed by the Minister under this subsection as Federal territory members of the investment committee; and members so reappointed or, as the case may be, appointed as Federal territory members by the Minister shall, while they continue to be employed in the Federal territory, comprise the sub-committee referred to in the next following subsection.

(4) The every day business of investment under this Act shall be transacted by the Federal territory members who shall comprise a sub-committee of the investment committee for the purpose and be responsible only to the Minister. The Minister shall appoint a date for the first report to the investment committee, and thereafter the sub-committee shall at intervals of not more than three months report to the investment committee on investments made by the sub-committee under its powers conferred by this subsection.

(5) Moneys for investment shall be invested only in securities in Nigeria authorised by the Trustee Investment Acts 1957 and 1962, and unless the Minister, after consultation with the Federal Minister charged with responsibility for finance otherwise directs, investments shall be restricted to securities created or issued by or on behalf of the Government of the Federation. In the application of this subsection, the question whether the Minister has in any case so acted and whether he has received such advice shall not be enquired into by any court.

*cf* 1962,  
No. 13.

(6) Subject to the provisions of this section the investment sub-committee may, and if required by the investment committee shall, from time to time give directions either generally or specially as to the investment of any moneys held for such purpose; and for the guidance of the investment committee or of the sub-committee as the case may require, the Director shall give such information as to moneys in the Fund and other matters as the investment committee or the sub-committee may reasonably require.

(7) The investment committee and the sub-committee of the investment committee may each regulate its own procedure at meetings and appoint their respective chairmen. Meetings of the investment committee shall be held as often as the Minister by notice in writing to the chairman may direct or require; but meetings of the investment sub-committee shall be held at such times and places as the chairman may appoint. If either chairman is absent, or refuses or is unwilling to act, the Minister may appoint a time and place for a meeting, and may nominate the chairman for the meeting.

(8) In the absence of the Director he may nominate some other officer of the Fund to attend meetings; and any officer so nominated shall, for any meetings attended be deemed to be a member of the investment committee or of the sub-committee, as the case may be.

(9) A Regional member may be removed from office for incompetence or inability to act if his nominator so directs the Minister, or a Regional member may resign his office by notice in writing to the Minister under this Act; and while they continue in office, regional members attending meetings of the investment committee shall be paid out of the Fund such expenses and allowances as the Federal Minister charged with responsibility for finance may from time to time approve.

5. Section thirty-five of the principal Act (which prescribes sundry offences) is amended by adding immediately after subsection (1) a new subsection (1A) as follows—

Failure to  
produce  
certain  
records as  
an  
offence.

“(1A) Any employer or other person required to produce to the Fund records of the contributions of a member, who fails without reasonable excuse (the proof whereof shall lie upon him) to produce a quarterly record within three months after the end of the quarter, commits an offence under this Act.”

6. The principal Act is further amended to the extent set out in the Schedule to this Act.

Miscellaneous  
amendments.

7.—(1) This Act may be cited as the National Provident Fund Act, 1964 and this Act and the principal Act may be cited together as the National Provident Fund Acts, 1961 and 1964.

Short title  
citation and  
application.

(2) This Act shall apply throughout the Federation.

## SCHEDULE

## Section 6

<i>Number</i>	<i>Short title</i>	<i>Extent of amendment</i>
1961 No. 20	The National Provident Fund Act, 1961	In section sixteen by repealing the words "jointly and"; Section twenty-nine is repealed; In section thirty by repealing all words from the commencement as far as the word "section", and by substituting for the marginal note the words "Power to purchase land, etc.".



ARRANGEMENT OF SECTIONS

*Section*

- |   |   |
|---|---|
| <ol style="list-style-type: none"> <li>1. Establishment and functions of Nigerian Legion.</li> <li>2. Management of affairs of Legion.</li> <li>3. Membership of the Legion.</li> <li>4. Financial provisions.</li> <li>5. Annual report.</li> <li>6. Winding-up of N.E.W.A.</li> </ol> | <ol style="list-style-type: none"> <li>7. Interpretation.</li> <li>8. Short title, extent and commencement.</li> </ol> <p>SCHEDULES :</p> <p>First Schedule—Constitutions etc. of councils.</p> <p>Second Schedule—Enactments repealed.</p> |
|---|---|

**1964, No. 18**

AN ACT TO MAKE FRESH PROVISION WITH RESPECT TO THE WELFARE OF EX-SERVICEMEN ; AND FOR PURPOSES CONNECTED THEREWITH.

[See section 8 (2)]

Commencement.

BE IT ENACTED by the Legislature of the Federation of Nigeria in this present Parliament assembled and by the authority of the same as follows :—

Establishment and functions of Nigerian Legion.

1.—(1) There shall be established, as the successor of the Nigerian Ex-Servicemen's Welfare Association, an association to be known as the Nigerian Legion, which shall be a body corporate by the name aforesaid and of which every ex-serviceman shall be entitled to be a member.

(2) The Legion shall be charged with the general function of promoting the welfare of ex-servicemen and comradeship among ex-servicemen.

(3) For the purpose of performing the general function aforesaid it shall in particular be the duty of the Legion to take such steps as it considers to be appropriate and within its resources with a view to—

- (a) raising money for the purposes of the Legion ;
- (b) affording help, either by way of grants of money or otherwise, to ex-servicemen appearing to the Legion to be in need of assistance ;
- (c) establishing and maintaining hostels for ex-servicemen appearing to the Legion to be incapacitated by old age or illness ; and
- (d) providing centres at which advice on matters affecting their interests may be obtained by ex-servicemen.

References in this subsection to ex-servicemen include references to members of the families of ex-servicemen and of deceased ex-servicemen.

(4) The Legion shall have power to do such things as it considers expedient for the purpose of performing its functions, so however that the Legion shall not, without the previous consent in writing of the Minister,—

- (a) dispose of or charge any land held for the purposes of the Legion, or any interest in land so held ; or
- (b) borrow money ; or
- (c) enter into a contract to employ any person.

(5) The Minister may from time to time give to the Legion directions in writing with respect to the performance of its functions ; and it shall be the duty of the Legion to comply with the directions.

Management of affairs of Legion.

2.—(1) There shall be established for the purposes of the Legion a national council as respects the Federation and local councils as respects each territory within the meaning of the Constitution of the Federation ; and the provisions of the First Schedule to this Act shall have effect with respect to the constitutions of those councils and the other matters there mentioned.

(2) Subject to the provisions of subsections (3) to (6) of this section, the affairs of the Legion shall be managed by the national council, and references to the Legion in this Act shall be construed accordingly ; and without prejudice to the generality of the foregoing provisions of this subsection—

(a) any thing falling to be done by or to the Legion shall be done by or to the national council on behalf of the Legion, or by or to such person acting as the representative of the national council as that council may determine ; and

(b) in particular, any contract or instrument which, if made or executed by a person not being a body corporate, would not be required to be under seal may be made or executed on behalf of the Legion by any person generally or specially authorised to act for that purpose by the national council.

(3) Subject to any directions given by the Minister in pursuance of this Act, the national council may charge a regional council established by this Act or the Lagos council with the performance, in accordance with such conditions as the national council may specify, of any of the functions of the national council falling to be performed within the territory in question.

(4) Subject to any such directions as aforesaid, a regional council may charge the council of any area into which the relevant Region is divided in pursuance of the First Schedule to this Act with the performance, in accordance with such conditions as the regional council may specify, of any of the functions of the regional council falling to be performed within the area in question.

(5) Subject to any such directions as aforesaid, the Lagos council and an area council established by this Act may charge the council of any sub-area into which the Federal territory or, as the case may be, the relevant area is divided in pursuance of the First Schedule to this Act with the performance, in accordance with such conditions as the Lagos or area council may specify, of any of the functions of the Lagos or area council falling to be performed within the sub-area in question.

(6) If it appears to the Minister that any council established by this Act has failed to carry on its activities in a proper manner, he may by order provide that all the functions of that council, or such of those functions as may be specified by the order, shall be exercisable by the Minister or by such other person as may be specified by the order, to the exclusion of that council, during such period as may be so specified ;

and an order under this subsection may require the making of payments to the Minister or the other person aforesaid, out of the fund established in pursuance of this Act, of such amounts specified by the order as the Minister considers appropriate for the purposes of the functions to which the order relates.

3.—(1) A person shall be a member of the Legion if—

Membership  
of the  
Legion.

(a) he applies to the Legion in the prescribed manner to be enrolled as such a member ; and

(b) he satisfies the Legion that he is an ex-serviceman.

(2) It shall be the duty of the Legion—

(a) to establish and maintain a list of the persons who are for the time being members of the Legion ; and

(b) to make arrangements for the issue to each member of the Legion of a membership card in the prescribed form bearing a photograph of the member to whom it is issued and stating his name and such other particulars (if any) as may be prescribed.

4.—(1) The Legion shall establish and maintain a fund from which there shall be defrayed all expenditure incurred by the Legion.

Financial  
provision.

(2) There shall be paid or credited to the fund—

(a) such sums out of moneys provided by Parliament as Parliament may from time to time determine ; and

(b) the assets of the association mentioned in section six of this Act which are transferred to the Legion in pursuance of that section ; and

(c) all other assets from time to time accruing to the Legion.

(3) The fund shall be managed in accordance with rules made by the Minister and the Minister of the government of the Federation responsible for finance, acting jointly ; and, without prejudice to the generality of the power to make rules conferred by this subsection, the rules shall in particular include provision—

(a) specifying the manner in which the assets of the fund are to be held and regulating the making of payments to and from the fund ;

(b) requiring the keeping of proper accounts and records for the purposes of the fund in such form as may be specified by the rules ;

(c) for securing that the accounts are audited periodically by an auditor appointed by the Ministers aforesaid, acting jointly ;

(d) requiring copies of the accounts and of the auditor's report on them to be furnished to the Minister as soon as may be after the end of the period to which the accounts relate ; and

(e) requiring the Minister to lay before each House of Parliament copies of all accounts and reports received by him in pursuance of the last foregoing paragraph.

5. It shall be the duty of the Legion to furnish to the Minister, as soon as may be after the end of each year, a report on the activities of the Legion during that year ; and the Minister shall lay before each House of Parliament a copy of each report received by him in pursuance of this section.

Annual  
report.

Winding-up  
of N.E.W.A.

Cap. 136

6.—(1) The Minister shall by order provide for the winding-up of the affairs of the association established by the Nigerian Ex-Servicemen's Welfare Association Act and for the transfer to the Legion of the assets and liabilities of the association ; and an order made in pursuance of this subsection may contain such incidental and supplementary provisions as the Minister considers expedient for the purposes of the order.

(2) When it appears to the Minister that the affairs of the said association have been wound up, he shall by order declare the association to be dissolved on such day as may be specified by the order ; and the enactments mentioned in the first and second columns of the Second Schedule to this Act are hereby repealed on the day so specified to the extent shown in the third column of that Schedule.

Interpretation.

7. In this Act, except so far as the context otherwise requires, the following expressions have the meanings hereby assigned to them respectively, that is to say—

“ex-serviceman” means a person of African race who is normally resident in Nigeria and who is not a whole-time member of the armed forces of the Federation but has been either such a member or a whole-time member at any time before the first day of October, 1963, of the armed forces of the Crown ;

“functions” includes powers and duties ;

“the Lagos council” means the council established in respect of the Federal territory by paragraph 4 of the First Schedule to this Act ;

“the Minister” means the Minister of the government of the Federation charged with responsibility for ex-servicemen ;

“prescribed” means prescribed by regulations ; and

“regulations” means regulations made by the Minister.

Short title,  
extent and  
commence-  
ment.

8.—(1) This Act may be cited as the Nigerian Legion Act, 1964, and shall apply throughout the Federation.

(2) The provisions of this Act shall come into force on such day as the Minister may by order appoint, and different days may be appointed in pursuance of this subsection as respects different provisions.

## SCHEDULES

### Section 2.

#### FIRST SCHEDULE

##### Constitutions etc. of councils

###### *Area and sub-area councils*

1. The Minister may by order make provision for dividing each Region into areas, and each such area and the Federal territory into sub-areas, for the purposes of this Act.

2.—(1) There shall be established in respect of each sub-area a council consisting of such number of members as the Minister may by order specify for that sub-area, who, subject to the provisions of this Schedule, shall be elected by ex-servicemen resident in the sub-area from among their own number.

(2) Each sub-area council shall select a chairman of the council from among the members of the council.

3.—(1) There shall be established in respect of each area a council consisting of—

(a) the chairmen of the councils of the sub-area into which the area is divided ; and

(b) such number of other members as the Minister may by order specify for that area, who, subject to the provisions of this Schedule, shall be elected by ex-servicemen resident in the area from among such of their own number as are not members of a sub-area council.

(2) Each area council shall select a chairman of the council from among the members of the council.

#### *Councils for the Regions and Lagos*

4.—(1) There shall be established in respect of each Region and the Federal territory respectively a council consisting, in the case of a Region, of the chairmen of the councils of the areas into which the Region is divided and, in the case of the Federal territory, of—

(a) the chairmen of the councils of the sub-areas into which the territory is divided ; and

(b) such number of other members as the Minister may by order specify for the territory, who, subject to the provisions of this Schedule, shall be elected by ex-servicemen resident in the territory from among such of their own number as are not members of a sub-area council.

(2) Each council established by this paragraph shall select a chairman of the council from among the members of the council.

#### *The national council*

5.—(1) There shall be established in respect of the Federation a council, to be known as the National Council of the Nigerian Legion, consisting of the following members, that is to say—

(a) two ex-servicemen nominated by the Minister ;

(b) the chairmen of the regional councils and the Lagos council ;

(c) six members of the regional council for Northern Nigeria selected by that council ;

(d) four members of the regional council for Eastern Nigeria selected by that council ;

(e) two members of the regional council for Western Nigeria selected by that council ;

(f) two members of the regional council for Mid-Western Nigeria selected by that council ; and

(g) two members of the Lagos council selected by that council.

(2) The Minister shall designate one of the two members of the national council nominated by him as the chairman of the council and the other of them as the vice-chairman of the council.

#### *Elections*

6.—(1) Provision may be made by regulations for the election of those members of councils who are required to be elected by ex-

servicemen, and, without prejudice to the generality of the powers conferred by the foregoing provisions of this paragraph, the regulations may provide—

- (a) for the preparation of lists of ex-servicemen qualified in accordance with the regulations to vote at elections ;
- (b) for the delimitation of electoral wards ;
- (c) for the nomination of candidates and for securing that no person is a candidate for election as a member of more than one council ;
- (d) for the conduct of polls ;
- (e) for declaring an election void as respects a council or an individual candidate ; and
- (f) for the determination of questions arising in connection with an election.

(2) Regulations made in pursuance of this paragraph shall contain provision for ensuring that elections of members of councils are held at such time (not being earlier than the beginning of the period of three months ending with the time when existing members vacate office by the effluxion of time in pursuance of sub-paragraph (2) of the next following paragraph) as to secure that the results of the elections are, so far as practicable, declared before existing members vacate office as aforesaid.

(3) Nothing in the foregoing provisions of this Schedule shall be construed as preventing a person from being a candidate at an election held in pursuance of this Schedule by reason only of the fact that he is an existing member of a council.

#### *Tenure of office*

7.—(1) A person elected as a member of a council before the expiration of the year nineteen hundred and sixty-five shall take office as such a member at such time as may be prescribed ; and a person so elected after the expiration of that year shall take office with effect from the time at which former members of the council in question last vacated office in pursuance of the next following sub-paragraph.

(2) All persons who, immediately before the expiration of the year nineteen hundred and sixty-six, hold office as members of councils shall vacate office at the expiration of that year ; and all persons holding office as such members immediately before the expiration of the period of three years beginning with the first day of January, nineteen hundred and sixty-seven, or of any period beginning with that day which is a multiple of three years, shall vacate office on the expiration of that period.

(3) A member of a council (other than a person who is such a member by virtue of his being the chairman of another council) may at any time resign his office by notice in writing to the council.

(4) If it appears to the Minister, after such enquiry as he thinks fit, that a member of a council is incapable by reason of illness of performing the duties of his office or has conducted himself in such a manner as to be unfit to continue as a member of the council, the Minister may, by notice in writing to the council, declare the office of that member to be vacant.

(5) Regulations may provide for the filling of the office of a member of a council which has become vacant otherwise than by virtue of sub-paragraph (2) of this paragraph.

*Proceedings of councils*

8.—(1) Subject to the provisions of section twenty-six of the Interpretation Act, 1964 (which provides for the decisions of a statutory body to be taken by a majority of the members of the body and for the person presiding at a meeting of such a body to have a second or casting vote), the national council, each regional council and the Lagos council respectively shall make standing orders with respect to its proceedings. 1964, No. 1.

(2) In exercising the power to make standing orders conferred by the foregoing sub-paragraph—

(a) the national council shall comply with any directions given to it in that behalf by the Minister ; and

(b) a regional council and the Lagos council shall comply with any directions given to it in that behalf by the national council ;

but nothing in this sub-paragraph shall be construed as derogating from the generality of subsection (5) of section one of this Act.

(3) Each regional council shall make standing orders with respect to the proceedings of the councils of the areas and sub-areas into which the relevant Region is divided in pursuance of this Schedule, and the Lagos council shall make standing orders with respect to the proceedings of the councils of the sub-areas into which the Federal territory is so divided.

(4) A council may, subject to the provisions of any standing orders having effect as respects the council, regulate its own procedure.

9. The quorum of the national council shall be twelve, and the quorum of any other council shall be equal to one third of the members of the council (any vacancy being treated as filled and any fraction being disregarded).

10.—(1) Subject to the provisions of any standing orders of the council, a council shall meet whenever it is summoned by its chairman ; and if the chairman is required so to do by notice given to him by a number of members of the council who constitute a quorum, he shall summon a meeting of the council to be held within seven days from the date on which the notice is given.

(2) At any meeting of a council its chairman shall preside while he is present, but if he is absent the members of the council present at the meeting shall select one of their number to preside at that meeting during his absence, so however that the vice-chairman of the national council shall, while he is present at a meeting of the council when its chairman is absent, preside at that meeting.

(3) Notwithstanding anything in the last two foregoing paragraphs or the foregoing provisions of this paragraph, the first meeting of each council shall be summoned in the prescribed manner and provision shall be made by regulations as to the person who shall preside and the procedure which shall be followed at that meeting.

11.—(1) At every meeting of a council there shall be recorded in the prescribed form minutes of the proceedings at the meeting.

(2) Copies of the minutes of a meeting of the national council, a regional council and the Lagos council shall, before the expiration of the period of fifteen days beginning with the date of the meeting, be furnished by the council in question to the Minister and—

(a) in the case of a meeting of a regional council, to the Premier of the Region in question and to the national council; and

(b) in the case of a meeting of the Lagos council, to the national council.

#### Miscellaneous

12. The validity of any proceedings of a council shall not be affected by any vacancy in the membership of the council, or by any defect in the appointment of a member of the council, or by reason that a person not entitled to do so took part in the proceedings.

13. Any member of a council who has a personal interest in any matter proposed to be considered by the council shall disclose his interest to the council and, in so far as the standing orders of the council so provide, shall not vote on any question relating to that matter.

14. In this Schedule, except so far as the context otherwise requires, "council" means any council established by this Schedule.

#### Section 6.

#### SECOND SCHEDULE

#### Enactments repealed

<i>Chapter or number</i>	<i>Short title</i>	<i>Extent of repeal</i>
Cap. 157 of the 1948 edition of the Laws of Nigeria.	The Nigerian Ex-Servicemen's Welfare Association (Vesting of Certain Charitable Funds) Act.	The whole Act.
L.N. 131 of 1954.	The Adaptation of Laws Order, 1954.	Sub-paragraph (1) of paragraph 2 in its application to chapter 157 of the said edition of 1948, and so much of the Third Schedule as relates to that chapter.
Cap. 136.	The Nigerian Ex-Servicemen's Welfare Association Act.	The whole Act.
L.N. 257 of 1959.	The Transfer of Functions (Lagos) Order, 1959.	So much of the First Schedule as relates to chapter 156 of the said edition of 1948.
No. 42 of 1960.	The Nigerian Ex-Servicemen's Welfare Association (Amendment) Act, 1960.	The whole Act.
1961, No. 67.	The Nigerian Ex-Servicemen's Welfare Association (Amendment) Act, 1961.	The whole Act.
L.N. 47 of 1961.	The Adaptation of Laws (Miscellaneous Provisions) Order, 1961.	So much of the Schedule as relates to chapter 136.

**INSURANCE (MISCELLANEOUS PROVISIONS)  
ACT, 1964**



1964, No. 19

AN ACT TO PROVIDE FOR THE INVESTMENT IN NIGERIAN SECURITIES, BY PERSONS CARRYING ON BUSINESS AS INSURERS IN NIGERIA, OF CERTAIN ASSETS OF THE BUSINESS ; TO MAKE FURTHER PROVISION AS RESPECTS CERTAIN CONTRACTS OF INSURANCE ; AND FOR PURPOSES CONNECTED WITH THE MATTERS AFORESAID.

[See section 7 (3)]

Commence-  
ment.

BE IT ENACTED by the Legislature of the Federation of Nigeria in this present Parliament assembled and by the authority of the same as follows :—

1.—(1) A contract of insurance to which this section applies shall be void in so far as it makes provision for compensation in respect of local risks unless the party undertaking to pay the compensation is a Nigerian company.

Additional  
provisions  
as respects  
insurance  
against local  
risks.

(2) Where a person has, as a principal and not as a servant or agent, received in any financial year payments by way of premium made in respect of any period under contracts of insurance to which this section applies he shall, subject to the next following subsection, take such steps as may be necessary to secure that at all times during the next following financial year he is the owner of Nigerian investments which are free from encumbrances and equal in value to not less than two-fifths of such proportion of the aggregate amount of those payments as is attributable in accordance with insurance practice to local risks ; and in calculating that proportion there shall be deducted the proportion so attributable to the local risks in question of the aggregate amount of any payments by way of premium made by that person under contracts of re-insurance in respect of the same period or any part of it.

(3) A person who owns Nigerian investments in pursuance of the last foregoing subsection and who satisfies or proposes to satisfy a claim which—

(a) is made in respect of local risks in pursuance of a contract of insurance to which this section applies, or of such a contract as renewed with or without modifications ; and

(b) falls to be treated in accordance with insurance practice as an abnormally large claim,

shall not be treated as failing to comply with the provisions of that subsection if—

(i) he realises or charges such of the investments as is appropriate in accordance with insurance practice for the purpose of satisfying that claim or of replacing moneys used to satisfy it ; and

(ii) the period in respect of which he relies on the provisions of paragraph (i) of this subsection in connection with that claim does not exceed thirty days.

(4) A person who fails to comply with the provisions of subsection (2) of this section shall be guilty of an offence and liable on conviction on indictment to a fine of an amount not exceeding one thousand pounds.

(5) This section applies to contracts of insurance made on or after the date when this subsection comes into force, other than contracts of endowment insurance and contracts of such descriptions, if any, as may be prescribed for the purposes of this section.

(6) The foregoing provisions of this section shall come into force on such date as the Minister may by order appoint (not being earlier than the first day of April, one thousand nine hundred and sixty-four), and different dates may be so appointed for different subsections ; and subsection (2) of this section shall, as respects the financial year next following that in which that subsection comes into force, have effect as if for the words "two-fifths" there were substituted the words "one-fifth".

Additional provisions as respects endowment insurance.

2.—(1) A contract of endowment insurance made in Nigeria on or after the date when this section comes into force under which payments by way of benefit are expressed to become payable in respect of an individual who is a citizen of Nigeria at the time when the contract is made shall be void unless—

(a) the party undertaking to make the payments is a Nigerian company ; and

(b) the contract is a Nigerian contract of endowment insurance ; so however that the foregoing provisions of this subsection shall not apply to a contract of re-insurance if it does not provide for the making of payments corresponding to payments by way of benefit in respect of any individual which in the aggregate are less than, or of less value than, forty thousand pounds.

(2) Every person who, as a principal and not as a servant or agent, carries on endowment insurance business shall take such steps as may be necessary to secure that, on and after the first day of April, one thousand nine hundred and sixty-six, he is the owner of Nigerian investments free from encumbrances which are equal in value to the aggregate of—

(a) the value at the time of the close of business on the thirty-first day of March, one thousand nine hundred and sixty-two, of such of the assets of each relevant fund as are attributable in accordance with insurance practice to Nigerian contracts of endowment insurance ; and

(b) the value of such of the assets paid or credited to each relevant fund after the time aforesaid as are so attributable, reduced by the amount of any payments made out of the relevant fund in question after the time aforesaid for the purpose of satisfying liabilities and expenses so attributable which fall to be satisfied out of that fund in accordance with insurance practice and by the amount of such other payments, if any, as may be prescribed.

In this subsection "relevant fund", in relation to a person carrying on endowment insurance business, means a fund maintained by him to which are paid or credited moneys received by him for the purposes of the business.

(3) In relation to a person who begins to carry on endowment insurance business after the thirty-first day of March, one thousand nine hundred and sixty-two, the references in the last foregoing subsection to that date shall be construed as references to the thirty-first day of March of the year next following that in which he begins to carry on the business.

(4) Where apart from this subsection any amount in respect of payments by way of premium under a contract of endowment insurance would, under the provisions of the Income Tax Management Act, 1961, fall to be deducted in ascertaining, in respect of any year of assessment within the meaning of that Act beginning after the end of the year one thousand nine hundred and sixty-four, the income or loss for income tax purposes of any individual, the amount to be so deducted shall not exceed a sum equal to one-third of the payments in question unless either—

1961,  
No. 21.

(a) the contract is a Nigerian contract of endowment insurance ; or

(b) the individual furnishes to the Board of Inland Revenue a certificate in the prescribed form issued by the person by whom payments by way of benefit fall to be made in pursuance of the contract stating that the last-mentioned person is, or that that person and any relevant re-insurers together are, the owner of Nigerian investments which are—

(i) free from encumbrances ; and

(ii) equal in value to the aggregate of the relevant payments by way of premium or of such proportion of them as may be prescribed ; and

(iii) allocated to those payments in accordance with regulations made in pursuance of paragraph (b) of section four of this Act ; or

(c) the contract was made before the first day of March, one thousand nine hundred and sixty-four.

In this subsection "relevant re-insurer", in relation to a contract of endowment insurance, means a person who, under a contract of re-insurance relating to the contract of endowment insurance, has undertaken to make payments corresponding to any payments by way of benefit payable under the contract of endowment insurance.

This subsection applies to Lagos only.

(5) A person who fails to comply with the provisions of subsection (2) of this section shall be guilty of an offence and liable on conviction on indictment to a fine of an amount not exceeding one thousand pounds; and a person who issues a certificate for the purposes of paragraph (b) of the last foregoing subsection which he knows to be false in a material particular or recklessly issues such a certificate which is false in a material particular shall be guilty of an offence and liable on summary conviction to imprisonment for a term not exceeding six months or a fine of an amount not exceeding two hundred pounds or both.

Appoint-  
ment and  
functions of  
inspector.

3.—(1) There shall be an inspector for the purposes of this Act, whose office shall be an office in the department of government for which responsibility is assigned to the Minister and who shall be a person having such qualifications and experience as are appropriate for a person required to perform the functions conferred on the inspector by virtue of this Act; so however that, if the Public Service Commission of the Federation so directs, the person who is the registrar for the purposes of the Insurance Companies Act, 1961, shall also be the inspector for the purposes of this Act.

1961,  
No. 53.

(2) Provision may be made by regulations as to the functions of the inspector and, without prejudice to the generality of the power to make regulations conferred by the foregoing provisions of this subsection, the regulations may in particular include provision—

(a) requiring copies of records maintained in pursuance of this Act to be furnished to the inspector periodically and on such specific occasions as he may determine;

(b) authorising the inspector to examine and take copies of or extracts from any books or papers appearing to him to be connected with contracts of insurance, and requiring persons having such books and papers in their possession or under their control to produce them for examination by the inspector;

(c) requiring persons appearing to the inspector to be, or to have been, carrying on business as insurers in Nigeria to furnish to him, either orally or in writing as he may direct, any information relating to the business which he may reasonably require them to furnish for the purpose of enabling the inspector to satisfy himself whether provisions of this Act or of regulations have been infringed.

(3) It shall be the duty of the inspector in exercising his functions not to interfere unreasonably with the affairs of persons affected by his activities.

(4) Any power conferred on the inspector by virtue of this Act may be exercised by the inspector in person and by any public officer who produces an instrument signed by the inspector authorising him to exercise that power on behalf of the inspector; and references to the inspector in this section shall be construed accordingly.

Supple-  
mentary  
administra-  
tive  
provisions.

4. Without prejudice to any other power to make regulations conferred by this Act, provision may be made by regulations—

(a) for securing that a person who is required to own Nigerian investments by virtue of this Act shall maintain in accordance with the regulations a record containing—

- (i) particulars of the investments from time to time owned by him for the purposes of this Act ; and
- (ii) particulars of the contracts in respect of which the investments are owned ; and
- (iii) such other particulars, if any, as may be prescribed ;
- (b) for requiring a person who proposes to issue a certificate for the purposes of paragraph (b) of subsection (4) of section two of this Act to secure the allocation of Nigerian investments, in accordance with the regulations, to the payments in respect of which he proposes to issue the certificate ; and
- (c) as to the manner of determining—
  - (i) any value falling to be determined for the purposes of this Act ; and
  - (ii) whether a loan is adequately secured for those purposes by a mortgage or charge.

5.—(1) In this Act, “Nigerian investments” means property of any of the following descriptions, that is to say—

Nigerian  
investments.

- (a) stock, notes, bonds and other securities issued by the government of the Federation or a Region ;
- (b) stock, shares and debentures issued by a body corporate established directly by a law in force in Nigeria, or issued by a Nigerian company ;
- (c) rights to receive payments by way of interest or dividend which have accrued due in respect of any such securities as are mentioned in the foregoing paragraphs ;
- (d) moneys standing to the credit of any current or deposit account maintained with a branch situated in Nigeria of a licenced bank within the meaning of the Banking Act ;
- (e) moneys standing to the credit of any deposit account maintained with a person who is carrying on business in Nigeria as a building society and is approved by the Minister for the purposes of this paragraph ;
- (f) an estate in fee simple absolute in possession in land in Nigeria, and a term of years absolute in possession in such land ;
- (g) rights to be repaid a loan which is adequately secured by a first mortgage of such an estate or term as is mentioned in the last foregoing paragraph, or by a first charge on machinery or plant situated in Nigeria ;
- (h) rights to receive payments by way of premium which have accrued due under contracts of insurance made in Nigeria ;
- (i) rights to be repaid a loan made in Nigeria to any person in consequence of his being a person who has undertaken to make payments by way of premium under a contract of endowment insurance, and rights to receive payments by way of interest which have accrued due on such a loan ;
- (j) property of such other descriptions, if any, as may be prescribed.

Cap. 19.

(2) Where by virtue of any provision of this Act a person is required to own Nigerian investments of any amount, he shall not be treated as satisfying that requirement unless—

(a) the investments allocated by him to satisfy that requirement include investments of the description mentioned in paragraph (a) of the foregoing subsection equal in value to one quarter of the amount in question ; and

(b) the investments so allocated do not include investments of the description mentioned in paragraph (f) of that subsection which exceed in value one-tenth of the amount.

Interpretation, etc.

6.—(1) In this Act the following expressions have the meanings hereby assigned to them respectively, that is to say—

“contract of endowment insurance” means a contract of insurance in which benefit is expressed to become payable on the occurrence of an event or circumstance which is certain to occur, or on the occurrence of any of a number of events or circumstances of which at least one is certain to occur, other than a contract of such description, if any, as may be prescribed for the purposes of this definition ;

“endowment insurance business” means the business of undertaking liability to make payments by way of benefit under contracts of endowment insurance in so far as the business is carried on in Nigeria ;

“insurance” includes re-insurance, and references to contracts of insurance shall be construed accordingly ;

“insurance practice” means normal insurance practice in Nigeria ;

“local risk” means an event or circumstance occurring within Nigeria ;

“the Minister” means the Minister of the government of the Federation responsible for insurance ;

“Nigerian company” means a company which is formed and registered under the Companies Act or which complies with the provisions of subsection (1) of section two hundred and thirty-nine of that Act (which relate to companies incorporated outside Nigeria which establish places of business within Nigeria) and includes, except in section five of this Act, an association of underwriters registered under the Insurance Companies Act, 1961, and any member of such an association ;

“Nigerian contract of endowment insurance” means a contract of endowment insurance which provides that all payments falling to be made in pursuance of the contract shall be payable in Nigerian money only ;

“prescribed” means prescribed by regulations ; and

“regulations” means regulations made by the Minister ;

and references in this Act to payments by way of benefit under a contract of endowment insurance shall be construed, in relation to such a contract which is a contract of re-insurance, as references to payments under the contract of re-insurance corresponding to payments by way of benefit.

(2) For the avoidance of doubt it is hereby declared that where a contract of insurance is renewed, the renewal constitutes a new contract of insurance for the purposes of this Act.

(3) Nothing in this Act shall be construed as purporting to affect any insurance undertaken by the government of a Region which does not extend beyond the limits of the Region.

7.—(1) This Act may be cited as the Insurance (Miscellaneous Provisions) Act, 1964.

Short title,  
extent,  
commence-  
ment and  
repeals.

(2) Except as provided by subsection (4) of section two of this Act, this Act shall apply throughout the Federation.

(3) Subject to the provisions of subsection (6) of section one of the Act, this Act shall come into force on such date as the Minister may by order appoint.

(4) Section twenty-eight of the Insurance Companies Act, 1961, and paragraph (b) of subsection (2) of section forty-four of that Act (which contain provisions for requiring insurance companies to invest a percentage of their profits in Nigeria) are hereby repealed.



## BILLS OF EXCHANGE ACT, 1964



1964, No. 20

AN ACT TO AMEND THE LAW RELATING TO BILLS OF EXCHANGE ; AND FOR PURPOSES CONNECTED THEREWITH.

[See section 5 (2)]

Commencement.

BE IT ENACTED by the Legislature of the Federation of Nigeria in this present Parliament assembled and by the authority of the same as follows :—

1.—(1) Where a banker, in good faith and in the ordinary course of business, pays a prescribed instrument drawn on him to a banker, he does not in doing so incur any liability by reason only of the absence of, or irregularity in, endorsement of the instrument and—

Payment by bankers of unendorsed cheques and other instruments.

(a) in the case of a cheque, he is deemed to have paid it in due course ;

(b) in the case of any other prescribed instrument, the payment discharges the instrument.

(2) A prescribed instrument which is unendorsed but appears to have been paid by the banker on whom it is drawn is evidence of the receipt by the payee of the sum mentioned in the instrument.

(3) For the purposes of subsection (1) of section sixty of the Bills of Exchange Act (which provides that in certain circumstances a cheque shall be deemed to be paid in due course though its endorsements are forged or unauthorised), a document payable to order which is a prescribed instrument by virtue of paragraph (b) of subsection (1) of section four of this Act shall be deemed to be a bill payable to order on demand.

Cap. 21.

2.—(1) A banker who gives value for, or has a lien on, a cheque payable to order which the payee delivers to him for collection either without endorsing it or without endorsing it regularly has such rights, if any, as he would have had if upon delivery the payee had endorsed it regularly in blank.

Protection of collecting bankers.

(2) Where a banker, in good faith and without negligence,—

(a) receives payment for a customer of a prescribed instrument to which the customer has no title or a defective title ; or

(b) having credited the customer's account with the amount of such a prescribed instrument, receives payment of the instrument for himself,

the banker does not incur any liability to the true owner of the instrument by reason only of his having received payment of it ; and a banker is not to be treated for the purpose of this subsection as having been negligent by reason only of his failure to concern himself with the absence of, or irregularity in, endorsement of a prescribed instrument of which the customer in question appears to be the payee.

(3) Section eighty-two of the Bills of Exchange Act (which contains provisions as to crossed cheques which are included in the provisions of subsection (2) of this section) is hereby repealed.

Extension of enactments relating to crossed cheques.

3. The provisions of the Bills of Exchange Act relating to crossed cheques shall, so far as applicable, have effect in relation to a prescribed instrument other than a cheque as those provisions have effect in relation to a cheque.

Interpretation, etc.

4.—(1) In this Act "prescribed instrument" means any of the following instruments, that is to say—

(a) a cheque ;

(b) a document issued by a customer of a banker which is not a bill but is intended to enable a person to obtain payment from the banker of the sum mentioned in the document ;

(c) a draft drawn by a banker upon himself and payable on demand at an office of his bank.

(2) This Act shall be construed as one with the Bills of Exchange Act, so however that references in this Act to a payee do not include references to an endorsee under a special endorsement.

(3) Nothing in this Act shall make negotiable an instrument which apart from this Act is not negotiable.

Short title, extent and commencement.

5.—(1) This Act may be cited as the Bills of Exchange Act, 1964, and shall apply throughout the Federation.

(2) This Act shall come into force on such day as the Minister of the government of the Federation responsible for finance may by order appoint.



ARRANGEMENT OF SECTIONS

Section

PART I—ESTABLISHMENT OF NAVY

1. Establishment, etc., of navy.
2. Establishment of naval reserve.

PART II—ESTABLISHMENT OF NAVY BOARD

3. Establishment of navy board.
4. Membership of board.
5. Powers of board.

PART III—ADMINISTRATION AND GOVERNMENT

*Command*

6. Command of the navy.
7. Powers of command of members of co-operating army or air force units.
8. Attachment of members of the navy to the army or air force.
9. Attachment of personnel and powers of command.
10. Regulations as to command.

*Officers*

11. Appointment of officers.
12. Promotion of officers, etc.
13. Recall of officers who have retired, etc.
14. Regulations as to officers.

*Enlistment and Terms and Conditions of Service*

15. Recruiting officers.
16. Enlistment.
17. Terms of enlistment.
18. Re-engagement and continuance in service.
19. Prolongation of service.

*Discharge and Transfer to the Reserve*

20. Discharge.
21. Transfer to the reserve.
22. Postponement of discharge or transfer pending proceedings for offences, etc.
23. Right of chief petty officer to discharge on reduction to ordinary rating.
24. Power to discharge.
25. Right of rating to purchase discharge.

*Miscellaneous and Supplementary*

26. Rules for reckoning service.
27. Validity of attestation and enlistment.
28. Pension provisions.
29. Provisions as to death and injury.
30. Liability for service outside Nigeria.
31. Interpretation of, and power to make certain regulations for, this Part.

PART IV—DISCIPLINE AND TRIAL AND PUNISHMENT OF NAVAL OFFENCES

32. Application.

*Misconduct in Action and Assistance to the Enemy*

33. Misconduct in action by persons in command.
34. Misconduct in action by other officers and ratings.
35. Obstruction of operations.
36. Corresponding with, supplying or serving with the enemy.

ARRANGEMENT OF SECTIONS—*continued**Section*

- 37. Wilful neglect and failure to rejoin forces, etc.
- 38. Offences against morale.
- 39. Sleeping on watch or abandoning post.
- 40. Neglect of duty.

*Mutiny*

- 41. Definition of mutiny.
- 42. Offences of mutiny.
- 43. Failure to suppress mutiny.

*Insubordination and Similar Offences*

- 44. Striking superior officer.
- 45. Disobedience or threatening superior officer.
- 46. Fighting and quarrelling.
- 47. Obstruction of provost officers.
- 48. Disobedience to standing orders.

*Desertion and Absence without leave*

- 49. Desertion.
- 50. Absence without leave, etc.
- 51. Assisting and concealing desertion and absence without leave.

*Navigation and Flying Offences*

- 52. Loss or hazarding of ship or aircraft.
- 53. Dangerous flying, etc.
- 54. Low flying.
- 55. Annoyance by flying.

*Prize Offences*

- 56. Prize offences by commanding officers.
- 57. Other prize offences.
- 58. Looting.

*Other Offences in respect of Ships and Aircraft*

- 59. Inaccurate certification of ships, etc.
- 60. Improper carriage of goods.

*Malingering and Drunkenness*

- 61. Malingering.
- 62. Drunkenness.

*Offences relating to Property*

- 63. Misapplication and destruction of public and service property.
- 64. Loss and waste of public and service property.
- 65. Offences in relation to property of members of forces.

*Offences relating to and by Persons in Custody*

- 66. Irregular arrest and confinement.
- 67. Permitting escape and unlawful release of prisoners.
- 68. Resisting arrest.
- 69. Escape from confinement.

*Offences in relation to Courts Martial and Civil Authorities*

- 70. Offences in relation to courts martial.
- 71. False evidence.
- 72. Obstruction of police officer arresting officer or rating.

*Miscellaneous Offences*

- 73. Injurious disclosures.
- 74. Making of false statements on enlistment.
- 75. Scandalous conduct of officer.
- 76. Ill-treatment of officers or rating of inferior rank.
- 77. Disgraceful conduct.
- 78. False accusation.
- 79. Conduct to prejudice of naval discipline.

*Attempts and Aiding and Abetting of Naval Offences*

- 80. Attempts to commit naval offences.
- 81. Aiding and abetting naval offences.

*Civil Offences*

- 82. Civil offences.

*Punishments*

- 83. Punishment of officers.
- 84. Punishment of ratings.

*Arrest*

- 85. Power to arrest offenders.
- 86. Provision for avoiding delay after arrest.

*Investigation of and Summary Dealing with Charges*

- 87. Investigation of charges by commanding officer.
- 88. Summary trial of officers.
- 89. Summary trial of ratings.
- 90. Charges to be dealt with summarily or by court martial.

*Court Martial : General Provisions*

- 91. Jurisdiction of courts martial.
- 92. Officers having power to convene courts martial.
- 93. Composition of courts martial.
- 94. Appointment of judge advocate.
- 95. Place and time for sitting of court martial.
- 96. Dissolution of court martial.
- 97. Challenges by accused.
- 98. Administration of oaths.
- 99. Court martial to sit in open court.
- 100. Decision of court martial.
- 101. Finding and sentence.
- 102. Power to convict of offence other than that charged.

## Section

ARRANGEMENT OF SECTIONS—*continued*

103. Rules of evidence.
104. Privileges of witnesses and others at court martial.
105. Summoning of witnesses.
106. Offences by civilians in relation to courts martial.
- Confirmation, Revision and Review of Proceedings of Courts Martial*
107. Confirmation of proceedings of court martial.
108. Petitions against finding or sentence.
109. Revision of findings of court martial.
110. Powers of confirming authority.
111. Confirming authorities.
112. Death sentence to be approved.
113. Review of findings and sentences of court martial.
114. Reconsideration of sentences of imprisonment.
- Review of Summary Findings and Awards*
115. Review of summary findings and awards.
- Findings of Insanity, etc.*
116. Provisions where accused found insane.
- Commencement, Suspension and Duration of Sentences*
117. Commencement of sentences.
118. Duration of sentences of imprisonment.
119. Special provisions as to civil prisons.
120. Serving of sentences outside Nigeria.
121. Country in which sentence of imprisonment is to be served.
122. Duties of persons in charge of prisons and others to receive prisoners.
- Trial and Time Limit of Persons ceasing to be Subject to Naval Law*
123. Trial, etc., of offences although offender no longer subject to naval law.
124. Limitation of time for trial of offences under this Act.
- Relations between Naval and Civil Courts and Finality of Trials*
125. Powers of civil courts.
126. Offences already disposed of not to be re-tried.
- Inquiries*
127. Boards of inquiry.
128. Inquiries into absence.
- Miscellaneous Provisions*
129. Restitution or compensation for theft, etc.
130. Promulgation of findings, etc.
131. Custody of proceedings of court martial and right to copies.
132. Indemnity for prison officers, etc.
- Redress of Complaints*
133. Complaints by officers and ratings.
134. Power to refer complaints by officer to the President.
- Rules of Procedure, etc.*
135. Rules of procedure and other rules. Interpretation of this part.
136. Interpretation of Part IV.
- PART V—APPEALS FROM COURTS MARTIAL
137. Right of Appeal.
138. Procedure for applying for leave to appeal or lodging appeal.
139. Determination of appeals in ordinary cases.
140. Powers of the Supreme Court in special cases.
141. Appeals to be final.
142. Supplementary powers of the Supreme Court.
143. Proceedings to be heard in absence of appellants.
144. Defence of appeals.
145. Right of appellant to present his case in writing.
146. Suspension of death sentence.
147. Persons not to be tried again where conviction quashed.
148. Removal of prisoners for purposes of proceedings.
149. Furnishing, on appeal, of documents relating to trial.
150. Duties of Registrar of the Supreme Court in respect of appeals, etc.
151. Rules of Court.
152. Saving of reviewing authorities' powers.
153. Composition of court.
154. Exercise of certain powers of the Supreme Court by a Justice.
155. General provisions as to procedure.
- PART VI—PAY, FORFEITURES AND DEDUCTIONS
156. Regulations as to pay.
157. Forfeitures and deductions: general provisions.
158. Forfeiture of pay for absence from duty.
159. Deductions for payment of civil penalties.
160. Compensation for loss occasioned by wrongful act or negligence.
161. Deductions for barrack damage.
162. Remission of forfeitures and deductions.

## Section

ARRANGEMENT OF SECTIONS—*continued*

## PART VII—GENERAL PROVISIONS

*Exemptions for Members of Navy*

- 163. Exemption from tolls, etc.
- 164. Exemption from taking in execution of property used for Naval purposes.
- 165. Exemptions as to arms and explosives.

*Deserters and Absentees without Leave*

- 166. Arrest of deserters and absentees without leave.
- 167. Proceedings before a civil court where persons suspected of illegal absence.
- 168. Deserters and absentees without leave surrendering to police.
- 169. Certificates of arrest or surrender.
- 170. Duties of superintendents of prisons and others to receive deserters and absentees.

*Offences relating to Naval Matters punishable by Civil Courts*

- 171. Punishment for pretending to be a deserter.
- 172. Punishment for procuring and assisting desertion.
- 173. Punishment for obstructing members of the navy.
- 174. Punishment for aiding malingering.
- 175. Unlawful purchase, etc., of naval stores.
- 176. Illegal dealings in documents relating to pay, pensions, mobilisation, etc.
- 177. Unauthorised use of, and dealing in, decorations, etc.
- 178. Intoxicating liquor not to be conveyed on board any naval ship.

*Evidence*

- 179. Special provisions as to evidence.
- 180. Proof of outcome of civil trial.
- 181. Evidence of proceedings of court martial.

*Reductions in Rank*

- 182. Restrictions on disrating.

*Miscellaneous Provisions*

- 183. Temporary reception into civil custody of persons under escort.
- 184. Avoidance of assignment of, or charge on, naval pay, etc.
- 185. Power of certain officers to take statutory declarations.

## PART VIII—RESERVISTS AND PENSIONERS

- 186. Reservists and pensioners.
- 187. Annual training.
- 188. Calling out of reservists and pensioners to aid the civil power.

- 189. Calling out of reservists and pensioners on permanent service.

- 190. Punishment for non-attendance.
- 191. Record of illegal absence.
- 192. Discharge during service.
- 193. Regulations as to the reservists and pensioners.

## PART IX—APPLICATION OF THE ACT AND SUPPLEMENTARY PROVISIONS

*Application*

- 194. Application of the Act.
- 195. Application of the Act to women.
- 196. Application of the Act to civilians.
- 197. Application of the Act to passengers.

*Wills and Distribution of Property*

- 198. Ratings on enlistment to register the name of persons to whom estate is to be paid in event of his dying intestate.
- 199. Ratings' wills : special provisions.
- 200. Distribution in case of deceased ratings intestacy.
- 201. Payment of debts of deceased rating.
- 202. Property of deceased rating distributed subject to rights of creditors.
- 203. Deceased rating's money undisposed of applied to prescribed fund.
- 204. Application of money, etc., in case of desertion.
- 205. Uniforms and decorations of deceased rating.

*Miscellaneous*

- 206. Power to make regulations generally.
- 207. Powers exercisable in subsidiary legislation.
- 208. Provisions as to active service.
- 209. Execution of orders, instruments, etc.
- 210. Nigerian Navy Benefit Fund.
- 211. Rights of officers.
- 212. Application of other Acts.
- 213. Repeal and transitional provisions.
- 214. Savings.
- 215. Interpretation.

## SCHEDULES

- First Schedule—Officers who can try ratings summarily and powers, etc.
- Second Schedule—Alternative offences on conviction by court martial.
- Third Schedule—Transitional provisions.
- Fourth Schedule—Enactments repealed.

## 1964, No. 21

AN ACT TO MAKE OTHER PROVISION FOR THE ESTABLISHMENT, GOVERNMENT AND DISCIPLINE OF THE NIGERIAN NAVY AND OF THE NAVAL RESERVE AND TO PROVIDE FOR OTHER MATTERS CONNECTED THEREWITH OR ANCILLARY THERETO.

[Section 216 (1)]

Commencement.

BE IT ENACTED by the Legislature of the Federation of Nigeria in this present Parliament assembled and by the authority of the same as follows :—

## PART I.—ESTABLISHMENT OF NAVY

1.—(1) There shall be established and maintained in and for the Federal Republic a naval force to be known as the Nigerian Navy (hereafter in this Act referred to as “the navy”) which shall consist of such establishments as the President may, acting in accordance with the advice of the Council of Ministers, think fit, and such numbers of ships and other vessels, officers, non-commissioned officers and men as the navy board as constituted under this Act may, from time to time, prescribe.

Establishment, etc., of navy.

(2) The navy shall be charged with—

- (a) the naval defence of Nigeria ;
- (b) the duty of assisting in the enforcement of the customs laws of Nigeria ;
- (c) the making of hydrographic surveys ;
- (d) training in naval duties ; and
- (e) such other duties as the Council of Ministers may from time to time direct.

(3) It is hereby declared that the authority created by this Act to establish and maintain a naval force shall include authority to raise and maintain units of or including women and accordingly the provisions of this Act shall apply to women subject to section one hundred and ninety-five and to such modifications and adaptations as the President may by order specify from time to time.

(4) The navy shall not form part of the public service of the Federation.

2. There shall be established and maintained a naval reserve consisting of such numbers of officers and ratings who are transferred to it on completion of their period of service in the navy and of such others as may be prescribed.

Establishment of naval reserve.

## PART II.—ESTABLISHMENT OF NAVY BOARD

3.—(1) Subject to the provisions of subsection (2) of this section, there shall be established a board to be known as the Navy Board (in this Act referred to as “the board”) which shall be responsible under the general authority of the Minister for matters relating to the command, discipline and administration of, and all other matters relating to, the navy.

Establishment of navy board.

(2) Notwithstanding the provisions of the preceding subsection, the board shall have no responsibility for the operational use of the navy and responsibility for any such use shall be vested in the commander subject to the overall directions of the Council of Ministers :

Provided that the Prime Minister may give to the commander such directions with respect to the operational use of the navy in Nigeria for the purpose of maintaining and securing public safety and public order, notwithstanding that the directions of the Council of Ministers have not been obtained, and the commander shall comply with those directions accordingly.

Membership  
of board.

4.—(1) Membership of the board shall consist of—

(a) the Minister, who shall be the chairman of the board ;

(b) the Minister of State responsible for the navy ;

(c) the commander ;

(d) the permanent secretary of the Ministry responsible for defence, who shall also be the secretary of the board ; and

(e) such other persons as the Prime Minister may appoint.

(2) The chairman may from time to time nominate any member of the board to perform the duties of the chairman at any meeting of the board at which the chairman is absent and such nomination may be either general or in respect of a particular occasion.

Powers of  
board.

5. The board may provide for all or any of the following matters—

(a) the organisation of the work of the board and the manner in which it shall perform its functions and the duties and responsibilities of the members thereof ;

(b) the delegation by notification in the Gazette to any member of the board of any of the powers or duties of the board ;

(c) the consultation by the board with persons other than members thereof ; and

(d) the procedure to be followed by the board in conducting its business.

### PART III—ADMINISTRATION AND GOVERNMENT

#### *Command*

Command of  
the navy.

6.—(1) The President on the advice of the Prime Minister may appoint such officer (in this Act referred to as “the commander”) as he thinks fit, in whom the command of the navy and the naval reserve shall be vested and, subject to the terms of his appointment and to such directions in relation to the operational use of the navy as may be given under subsection (2) of section three of this Act, the commander shall have the command, direction and general superintendence of the navy and the naval reserve.

(2) The Prime Minister before tendering advice shall consult with the board, but the question as to whether any consultation was held or what happened in the course of a consultation, shall not be enquired into by any court.

7. In so far as powers of command depend on rank, a member of any army or air force unit who is acting together with any naval unit (either with or without his unit or any part of it) shall have the like powers as a member of the navy of corresponding rank; and for the purposes of sections forty-four, forty-five and eighty-five of this Act any such member of an army or air force unit shall be treated as if he were a member of the navy of corresponding rank.

Powers of command of members of co-operating army or air force units.

8.—(1) Any member of the navy may be attached temporarily to the army or the air force by order of the competent naval authority.

Attachment of members of the navy to the army or air force.

(2) Regulations made by the appropriate service authorities may prescribe circumstances in which officers, chief petty officers, petty officers and men of the navy shall be deemed to be attached to the army or the air force, as the case may be, under the last foregoing subsection.

(3) In this section the expression "appropriate service authorities" means—

(a) in relation to attachment to the army, the Nigerian Army Council and the board; and

(b) in relation to attachment to the air force, the Nigerian Air Council and the board.

(4) A person shall not cease to be subject to naval law under this Act by reason only of attachment in pursuance of this section.

9.—(1) The Minister may by order direct that this section shall apply to any military, naval, or air force of a country (other than Nigeria) and where the Minister so directs the application of this section, the board—

Attachment of personnel and powers of command.

(a) may attach temporarily to the navy any member of the foreign country to which the other force belongs; or

(b) subject to anything to the contrary in the conditions applicable to his service, may place any member of the navy at the disposal of the service authorities of a foreign country for the purpose of being attached temporarily by those authorities to the foreign force or force of that country.

(2) Where a member of a foreign force is by virtue of this section attached temporarily to the navy as an officer or rating as the case may be he shall, for the period of attachment, be subject to this Act to the extent to which its application to him is not modified by any order which the Minister may make under this subsection, in like manner as if he were a member of the navy of relative rank; and accordingly he shall be so treated and have like powers of command and punishment over members of the navy.

(3) When the navy and a foreign force to which this section applies are serving together whether alone or not—

(a) any member of the foreign force shall be treated and shall have over members of the navy the like powers of command as if he were a member of the navy of relative rank; and

(b) if the forces are acting in combination, any officer of the foreign force appointed by the board, or in accordance with regulations made by the board, to command the combined force, or any part thereof, shall have over members of the navy the like powers of command

and punishment and may be invested with the like authority to convene, and confirm the findings and sentences of, courts martial as if he were an officer of the navy of relative rank and holding the same command.

(4) For the purposes of this section, forces shall be deemed to be serving together or acting in combination if and only if they are by order of the board declared to be so serving or so acting; and the relative rank of members of the navy and of the foreign force shall be such as may be prescribed by regulations made by the board.

Regulations  
as to  
command.

10. The President may make regulations as to the persons in whom command over the establishments and units or any member thereof is vested and as to circumstances in which such command as aforesaid is to be exercised and, without prejudice to the generality of the foregoing, may in such regulations provide for the duties, functions and powers of the command, its naval staff and officers, chief petty officers, petty officers and ratings.

### Officers

Appointment  
of officers.

11.—(1) No person shall be appointed to a commission in the navy unless he has been recommended by a board of officers set up by the board.

(2) A person recommended for appointment to a commission in the navy shall be appointed to a commission either for an indefinite period or for a specified time.

(3) Every officer on appointment shall be issued with a commission in the form prescribed by regulations made under section fourteen of this Act and signed by the President.

(4) The appointment of a person to a commission in the navy shall be notified in the Gazette.

Promotion  
of officers,  
etc.

12. All promotions of officers and any retirement or resignation of an officer shall be notified in the Gazette.

Recall of  
officers who  
have retired,  
etc.

13. An officer who has retired or was permitted to resign may be recalled in an emergency in accordance with regulations made under this Act, and on such recall, shall be liable to serve until he is released or discharged.

Regulations  
as to  
officers.

14. The President may make regulations governing the commissioning of officers, their terms of service, promotion, retirement, resignation and such other matters concerning officers of the navy as seem to him necessary.

### Enlistment and Terms and Conditions of Service

Recruiting  
officers.

15. Any person authorised in that behalf by regulations made under this Part of this Act may enlist recruits in the navy.

16.—(1) A person offering to enlist in the navy shall be given a notice in the prescribed form setting out questions to be answered on attestation and stating the general conditions and engagement to be entered into by him, and a recruiting officer shall not enlist any person in the navy unless satisfied by that person that he has given such a notice, understands it and wishes to be enlisted.

Enlistment.

(2) A recruiting officer shall not enlist a person under the apparent age of eighteen years unless consent to the enlistment has been given in writing by his parents or guardian or, where the parents or guardian are dead or unknown, by some persons approved by an administrative officer of the division of the Region or of the Federal territory, as the case may be, in which such person applying for enlistment resides.

17.—(1) The term for which a person enlisting in the navy may be enlisted shall be such a term, beginning with the date of his attestation, as is mentioned in the following provisions of this section.

Terms of enlistment.

(2) Where the person enlisting has apparently attained the age of eighteen years the term of enlistment shall, as may be prescribed, not exceed twelve years and be classed—

(a) as a term of regular service ; or

(b) as to a prescribed part, a term of regular service, and as to the remainder a term of service in the naval reserve.

(3) Where the person enlisting has not apparently attained the age of eighteen years the term shall be a term ending with the expiration of such period not exceeding twelve years as may be prescribed beginning with the date on which he attained such age, and be classed—

(a) as a term of regular service ; or

(b) as to a prescribed part, a term of regular service and as to the remainder, a term of service in the naval reserve.

18.—(1) Any rating before or after completing the term of his regular service may with the approval of the competent naval authority re-engage for such further period or periods of regular service and service in the reserve as may be prescribed :

Re-engagement and continuance in service.

Provided that—

(a) at the expiration of twelve years of continuous regular service from the date of his original attestation or the date when he apparently attained the age of eighteen years, whichever is the later, all reserve service due by him shall be deemed to have been completed ; and

(b) such further period or periods of regular service, together with the original period of regular service, shall not, except as provided by subsections (2) and (3) of this section, exceed a total continuous period of eighteen years of regular service from the date of the rating's original attestation or the date upon which he apparently attained the age of eighteen years, whichever is the later.

(2) Any rating who has completed a period of eighteen years of regular service may, if he so desires and with the approval of the competent naval authority, continue to serve to complete twenty-two years of regular service in all respects as if his term of regular service was still unexpired :

Provided that—

(a) it shall be lawful for him to claim his discharge at the expiration of three months after he has given notice to his commanding officer of his wish to be discharged ; and

(b) it shall be lawful for his commanding officer to give him three months notice of intention to discharge him.

(3) Any rating who has completed a period of twenty-two years of regular service may, if he so desires and with the approval of the competent naval authority, continue to serve in all respects as if his term of regular service was still unexpired.

Prolongation  
of service.

19. Any rating whose term of regular service expires during a state of war, insurrection, hostilities or public emergency may be retained in the navy and his service prolonged for such further period as the competent naval authority, with the approval of the Minister, may direct.

#### *Discharge and Transfer to the Reserve*

Discharge.

20.—(1) Unless otherwise prescribed by this Act, if a rating becomes entitled to be discharged, he shall be discharged with all convenient speed ; but until discharged he shall remain subject to naval law under this Act.

(2) If a rating entitled to be discharged is serving out of Nigeria and his term of service is prolonged under this Act, he shall be returned to Nigeria free of cost with all convenient speed, and be discharged on his arrival in Nigeria or, if he consents to his discharge being delayed, within six months from his arrival.

(3) Except in pursuance of the sentence of a court martial under service law, a rating shall not be discharged unless his discharge has been authorised by order of the competent naval authority in accordance with regulations made under this Part of this Act.

(4) Every rating shall be given on his discharge a certificate of discharge containing such particulars as may be prescribed :

Provided that a rating who is discharged within six months of the date of attestation shall not be entitled to receive a certificate of discharge.

(5) A rating who is discharged in Nigeria shall be entitled to be conveyed free of cost from the place where he is discharged to the place stated in his attestation paper to be the place where he was attested or to any place at which he intends to reside and to which he can be conveyed with no greater cost.

Transfer to  
the reserve.

21.—(1) Subject to the provisions of this Act, every rating whose term of service requires his transfer to the naval reserve shall, when so due, be transferred to that reserve ; but until he is so transferred, he shall remain subject to this Act.

(2) When a rating due for transfer to the naval reserve is serving outside Nigeria he shall be returned to Nigeria free of cost with all convenient speed and be transferred to such reserve on his arrival in Nigeria ; or if he consents to his transfer being delayed he shall be so transferred not later than six months from the date of his arrival in Nigeria.

(3) A rating who is transferred to the reserve in Nigeria shall be entitled to be conveyed free of cost from the place where he is transferred to the place stated in his attestation paper to be the place where he was attested or to any place at which he intends to reside and to which he can be conveyed with no greater cost.

(4) Any rating due for transfer to the naval reserve may, instead of being so transferred, be discharged forthwith by a competent naval authority without assigning any reason; and if a rating is so discharged the provisions of section twenty of this Act shall have effect instead of the foregoing provisions of this section.

**22. Notwithstanding anything in this Part of this Act—**

(a) a rating shall not be entitled to be discharged or transferred to the naval reserve at a time when he has become liable, as a person subject to service law, to be proceeded against for an offence against any of the provisions of service law by way of trial by court martial;

(b) a rating who is serving a sentence of imprisonment or detention awarded by a court martial under service law or by his commanding officer shall not be entitled to be discharged or transferred to the naval reserve during the currency of the sentence.

**23. Unless there exists a state of war or public emergency or there is an insurrection or hostilities have commenced, if a chief petty officer is reduced to ordinary rating he may thereupon claim to be discharged.**

**24. A rating may be discharged by a competent naval authority at any time during his term of engagement.**

**25.—(1) Subject to the provisions of section nineteen of this Act, a rating may claim his discharge within six months after the date of his first attestation, and if a competent naval authority approves, he shall, on payment of a sum of not more than ten pounds as may be determined by such authority, be discharged accordingly.**

(2) Nothing in section twenty of this Act shall apply to any such discharge, and until his discharge the rating shall remain subject to naval law under this Act.

*Miscellaneous and Supplementary*

**26.—(1) In reckoning the service of any rating for discharge or re-engagement or transfer to the naval reserve there shall be excluded therefrom—**

(a) all periods during which he has been absent from duty for any of the following causes—

(i) imprisonment;

(ii) desertion;

(iii) absence without leave exceeding twenty-eight days; and

(b) any period ordered by a court martial to be forfeited.

(2) Regulations under this Part of this Act may make provision for restoring service excluded by the provisions of subsection (1) of this section in consideration of good service or on other grounds justifying the restoration of service so excluded.

Postponement of discharge or transfer pending proceedings for offences, etc.

Right of chief petty officer to discharge on reduction to ordinary rating.

Power to discharge.

Right of rating to purchase discharge.

Rules for reckoning service.

Validity of  
attestation  
and enlist-  
ment.

27.—(1) Where a person has upon attestation made the prescribed declaration and thereafter receives pay as a rating—

(a) the validity of his enlistment shall not be called in question on the grounds of any error or omission in his attestation paper ;

(b) after the expiration of a period of three months from the date on which he made the said declaration he shall be deemed to have been validly enlisted notwithstanding any non-compliance with the requirements of this Act or any other ground whatsoever (not being an error or omission in his attestation paper) ;  
and accordingly he shall be a rating until his discharge under this Act.

(2) Where a person has received pay as a rating without having previously made the prescribed declaration for enlisting he may claim his discharge at any time ; and if he makes such claim, the claim shall be submitted as soon as may be to the competent naval authority who shall cause him to be discharged with all convenient speed. Until he is discharged, he shall be deemed to be a rating.

(3) Nothing in the foregoing provisions of this section shall be construed as prejudicing the determination of any question as to the term for which a person was enlisted or as preventing the discharge of a person who has not claimed his discharge.

Pensions  
provisions.  
Cap. 119.

28. For the purpose of the Military Pensions Act, service with the navy shall be deemed to be service in the Nigerian Army, and accordingly the provisions of that Act shall apply in respect of members of the navy as they apply to members of the Army, but subject to such modifications as may be prescribed by the Council of Ministers.

Provisions  
as to death  
or injury.

Cap. 119.

29.—(1) Every officer or rating of the navy to whom the Military Pensions Act applies who in the actual discharge of his duty and without his own default has received wounds or injuries or suffered illness shall, subject to the provisions of section twenty-eight of this Act, be entitled to the like benefits under the Military Pensions Act as are accorded to members of corresponding rank in the Army.

(2) The family of any officer or rating of the navy who has been killed or has died of wounds received on active service, or who has died through illness directly attributable to fatigue or exposure incidental to such service, shall be entitled to such benefits under the Military Pensions Act as may be prescribed.

(3) For the purpose of this section "family" and "active service" shall have the respective meanings as may from time to time be assigned to these expressions by regulations made under section thirty-one of this Act.

Liability for  
service out-  
side Nigeria.

30. The President may by order direct that any officer or rating of the navy shall proceed to any place outside Nigeria for the purpose of undergoing instruction or training or for duty or employment.

Interpreta-  
tion of, and  
power to  
make certain  
regulations  
for, this Part.

31.—(1) In this Part of this Act, "competent naval authority" means any officer designated as such by the board for the purposes of this Part of this Act.

(2) The board with the approval of the Minister may make such regulations as appear to the board to be necessary or expedient for the purpose of, or in connection with, the enlistment of recruits for the navy

and generally for carrying this Part of this Act into effect. Without prejudice to the generality of the foregoing such regulations may make provision—

- (a) for prescribing the form of attestation paper to be used; and
- (b) for an oath or affirmation to be administered on enlistment.

PART IV.—DISCIPLINE AND TRIAL AND PUNISHMENT  
OF NAVAL OFFENCES

32. The provisions of this Part of this Act as to discipline and offences shall apply only to persons who, for the time being, are subject to this Act, unless the context otherwise requires. Application.

*Misconduct in Action and Assistance to the Enemy*

33. Any officer or other person who, being in command of any ship, vessel, aircraft or shore establishment of the navy— Misconduct in action by persons in command

- (a) fails to use his utmost exertion to bring into action any such ship, vessel or aircraft which it is his duty to bring into action;
- (b) surrenders any such ship, vessel or aircraft to the enemy when it is capable of being successfully defended or destroyed;
- (c) fails to pursue any enemy whom it is his duty to pursue, or to assist to the utmost of his ability any friend whom it is his duty to assist;
- (d) in the course of any action by or against the enemy, improperly withdraws from the action or from his station, or fails in his own person and according to his rank to encourage the persons under his command to fight courageously; or
- (e) surrenders any such naval establishment, or any part of such establishment to the enemy when it is capable of being successfully defended or when it is his duty to cause it to be destroyed;

shall, if the offence is committed with intent to assist the enemy, be liable to death or any less punishment authorised by this Act, and in any other case shall be liable to imprisonment for any term or to any less punishment provided by this Act.

34. Any person, who not being in command of any ship, vessel, aircraft or shore establishment of the navy, fails when ordered to prepare for action by or against the enemy, or during any such action, to use his utmost exertions to carry the lawful orders of his superior officers into execution shall, if the offence is committed with intent to assist the enemy, be liable to death or any less punishment authorised by this Act, and in any other case shall be liable to imprisonment or to any less punishment provided by this Act. Misconduct in action by other officers and ratings.

35. Any person who wilfully delays or discourages, upon any pretext whatsoever, any action or service which has been commanded on the part of any of the armed forces of Nigeria, or of any forces co-operating therewith shall, if the offence is committed with intent to assist the enemy, be liable to death or any less punishment authorised by this Act, and in any other case, shall be liable to imprisonment for any term or to any less punishment provided by this Act. Obstruction of operations.

Corresponding with, supplying or serving with the enemy.

36. Any person who—

- (a) communicates with or gives intelligence to the enemy ;
- (b) fails to make known to the proper authorities any information received by him from the enemy ;
- (c) furnishes the enemy with supplies of any description ; or
- (d) having been made a prisoner of war, serves with or aids the enemy in the prosecution of hostilities or of measures calculated to influence morale, or in any other manner whatsoever not authorised by international usage ;

shall, if the offence is committed with intent to assist the enemy, be liable to death or any less punishment authorised by this Act, and in any other case, shall be liable to dismissal with disgrace from the armed forces of Nigeria or to any less punishment provided by this Act.

Wilful neglect and failure to rejoin forces, etc.

37.—(1) Any person who, through disobedience to orders or wilful neglect of his duty, is captured by the enemy shall be guilty of an offence against this section.

(2) Any person who, having been captured by the enemy, fails to take, or prevents or discourages any other person subject to service law who has been captured by the enemy from taking, any reasonable steps to rejoin the armed forces of Nigeria which are available to him or, as the case may be, to that other person shall be guilty of an offence against this section.

(3) Any person guilty of an offence against this section shall, on conviction by court martial, be liable to imprisonment or to any less punishment provided by this Act.

Offences against morale.

38. Any person who—

- (a) spreads (whether orally, in writing, by signal or otherwise) reports relating to operations of the armed forces of Nigeria, or of any forces co-operating therewith, or of any part of any of those forces, being reports calculated to create despondency or unnecessary alarm ; or
- (b) when before the enemy, uses words calculated to create despondency or unnecessary alarm,

shall, on conviction by court martial, be liable to imprisonment or to any less punishment provided by this Act.

Sleeping on watch or abandoning post.

39.—(1) Any person who, being in the presence or vicinity of the enemy or under orders to be prepared for action by or against the enemy, abandons his post improperly or sleeps upon his watch shall, on conviction by court martial, be liable to imprisonment for any term or to any less punishment authorised by this Act.

(2) Any person who, not being in the presence or vicinity of the enemy or under such orders as aforesaid, abandons his post improperly or sleeps upon his watch shall, on conviction by court martial, be liable to imprisonment for a term not exceeding two years or to any less punishment provided by this Act.

Neglect of duty.

40. Any person who neglects to perform or negligently performs any duty imposed on him shall be liable to dismissal with disgrace from the armed forces of Nigeria or to any less punishment provided by this Act.

*Mutiny*

41. In this Act "mutiny" means a combination between two or more persons subject to service law, or between persons two at least of whom are subject to service law—

Definition of mutiny.

(a) to overthrow or resist lawful authority in any of the armed forces of Nigeria or any forces co-operating therewith, or in any part of any of the said forces ;

(b) to disobey such authority in such circumstances as to make the disobedience subversive of discipline, or with the object of avoiding any duty or service against, or in connection with operations against, the enemy ; or

(c) to impede the performance of any duty or service in any of the armed forces of Nigeria or in any forces co-operating therewith, or in any part of any of the said forces.

42.—(1) Any person who—

Offences of mutiny.

(a) takes part in a mutiny involving the use of violence or the threat of the use of violence, or having as its object or one of its objects the refusal or avoidance of any duty or service against, or in connection with operations against the enemy or the impeding of the performance of any such duty or service ; or

(b) incites any person subject to service law to take part in such a mutiny, whether actual or intended, shall, on conviction by court martial, be liable to suffer death or any other punishment provided by this Act.

(2) Any person who takes part in any other form of mutiny or incites some other person subject to service law to take part therein whether such form of mutiny is actual or intended, shall be liable to imprisonment for any term or to any less punishment provided by this Act.

43. Any person who, knowing that a mutiny is taking place or is intended—

Failure to suppress mutiny.

(a) fails to use his utmost endeavours to suppress or prevent it, or

(b) fails to report without delay that the mutiny is taking place or is intended ;

shall, if the offence is committed with intent to assist the enemy, be liable, on conviction by court martial, to death or any less punishment authorised by this Act, and in any other case shall be liable to imprisonment for any term or to any less punishment provided by this Act.

*Insubordination and Similar Offences*

44. Any person who strikes or otherwise uses violence to, or offers violence to, his superior officer, whether or not that officer is exercising authority as such, shall, on conviction by court martial, be liable to imprisonment for any term or to any less punishment provided by this Act.

Striking superior officer.

45. Any person who—

(a) wilfully disobeys any lawful command of his superior officer (by whatever means communicated to him) ; or

Disobedience or threatening superior officer.

(b) uses threatening or insulting language to, or behaves with contempt to, his superior officer,

shall, on conviction by court martial, be liable to imprisonment or to any less punishment provided by this Act; but if the offence was not committed on active service or did not involve the striking or other use of violence, or offering of violence, to a superior officer exercising authority as such, a sentence of a term of imprisonment shall not exceed two years.

Fighting  
and quarrel-  
ling.

46. Any person who—

(a) fights or quarrels with any other person, whether subject to this Act or not; or

(b) uses threatening, abusive, insulting or provocative words or behaviour likely to cause a disturbance,

shall, of conviction by court martial, be liable to imprisonment for a term not exceeding two years, or to any less punishment provided by this Act.

Obstruction  
of provost  
officers.

47. Any person who—

(a) obstructs; or

(b) when called on, refuses to assist, any person known to him to be a provost officer, or to be a person (whether subject to this Act or not) lawfully exercising authority under or on behalf of a provost officer shall, on conviction by court martial, be liable to imprisonment for a term not exceeding two years or to any less punishment provided by this Act.

Disobedience  
to standing  
orders.

48.—(1) Any person who contravenes or fails to comply with any provision of orders to which this section applies, being a provision known to him, or which he might reasonably be expected to know, shall, on conviction by court martial, be liable to imprisonment for a term not exceeding two years or to any less punishment provided by this Act.

(2) This section applies to naval regulations, standing orders or memoranda, captain's or departmental orders or routine orders of a continuing nature.

#### *Desertion and Absence without Leave*

Desertion.

49.—(1) Any person who—

(a) deserts; or

(b) persuades or procures any person subject to service law to desert,

shall, on conviction by court martial, be liable to imprisonment or any less punishment provided by this Act; but a person shall not be liable to be imprisoned for more than two years unless—

(i) if the offence was against paragraph (a) of this subsection, he was on active service or under orders for active service at the time when it was committed; or

(ii) if the offence was against paragraph (b) of this subsection, the person in relation to whom it was committed was on active service or under orders for active service at that time.

(2) In addition to or in lieu of any punishment authorised by subsection (1) of this section, the court martial by whom a rating is convicted of desertion may direct that the whole or part of his service previous to the period as respects which he is convicted of having been a deserter shall, if he is not a reservist called out on permanent service, be forfeited.

(3) For the purposes of this Act a person deserts who—

(a) leaves any of the armed forces of Nigeria or, when it is his duty to do so, fails to join or rejoin any of those forces with (in either case) the intention, subsisting at the time of the leaving or failure or formed thereafter, of remaining permanently absent from his duty ; or

(b) being an officer, enlists in or enters any other of the armed forces of Nigeria without having resigned his commission, or being a rating, enlists in or enters in any other of the armed forces of Nigeria without having been discharged from his previous enlistment ; or

(c) absents himself without leave with intent to avoid serving at any place outside Nigeria or to avoid service or any particular service when before the enemy,

and references in this Act to desertion shall be construed accordingly.

50. Any person who—

(a) absents himself without leave ; or

(b) persuades or procures any person subject to service law to absent himself without leave,

shall, on conviction by court martial, be liable to imprisonment for a term not exceeding two years or to any less punishment provided by this Act.

Absence  
without  
leave, etc.

51. Any person who—

(a) knowingly assists any person subject to service law to desert or absent himself without leave ; or

(b) knowing that any person subject to service law has deserted or absented himself without leave, or is attempting to desert or absent himself without leave, fails to report that fact without delay, or fails to take any steps in his power to cause that person to be apprehended,

shall, on conviction by court martial, be liable to imprisonment for a term not exceeding two years or to any less punishment provided by this Act.

Assisting  
and conceal-  
ing desertion  
and absence  
without  
leave.

#### *Navigation and Flying Offences*

52. Any person who, either wilfully or by negligence—

(a) causes or allows to be lost, stranded or hazarded any ship or vessel in the Nigerian service, or

(b) causes or allows to be lost or hazarded any aircraft in the Nigerian service,

shall, on conviction by court martial be liable, if he acts wilfully or with wilful neglect, to imprisonment or to any less punishment provided by this Act, and in any other case shall be liable to imprisonment for a term not exceeding two years or to any less punishment provided by this Act.

Loss or  
hazarding  
ship or  
aircraft

Dangerous flying, etc.

53. Any person who is guilty of any act or neglect in flying or in the use of any aircraft, or in relation to any aircraft or aircraft material, which causes or is likely to cause loss of life or bodily injury to any person shall, on conviction by court martial, be liable to imprisonment or any less punishment provided by this Act :

Provided that if the offender has not acted wilfully or with wilful neglect he shall not be liable to be imprisoned for more than two years.

Low flying.

54. Any person who, being the pilot of a Nigerian service aircraft, flies it at a height less than the height from time to time prescribed by regulations made by the board under this Act except while taking-off or alighting, or in such other situation as may be so prescribed shall, on conviction by court martial, be liable to imprisonment for a term not exceeding two years or to any less punishment provided by this Act.

Annoyance by flying.

55. Any person who, being the pilot of a Nigerian service aircraft, flies it so as to cause, or to be likely to cause, unnecessary annoyance to any person shall, on conviction by court martial, be liable to imprisonment for a term not exceeding two years or to any less punishment provided by this Act.

#### *Prize Offences*

Prize offences by commanding officers.

56. Any person who, being in command of a Nigerian service ship, vessel or aircraft—

(a) having taken any ship, vessel or aircraft as prize, fails to send to the most convenient High Court in his opinion, in Nigeria all the ship papers or aircraft papers, as the case may be, found on board ;

(b) unlawfully makes any agreement for the ransoming of any ship, vessel, aircraft or goods taken as prize ; or

(c) in pursuance of any such agreement as aforesaid, or otherwise by collusion, restores or abandons any ship, vessel, aircraft or goods taken as prize,

shall, on conviction by court martial, be liable to imprisonment for a term not exceeding two years, or to any less punishment provided by this Act.

Other prize offences.

57. Any person who—

(a) strikes or otherwise ill-treats any person who is on board a ship, vessel or aircraft when taken as prize, or unlawfully takes from any such person anything in his possession ;

(b) removes out of any ship, vessel or aircraft taken as prize (otherwise than for safe keeping or for the necessary use and service of any of the armed forces of Nigeria) any goods not previously adjudged by a High Court in Nigeria to be lawful prize ; or

(c) breaks bulk on board any ship, vessel or aircraft taken as prize or detained in exercise of any belligerent right or under any enactment, with intent to embezzle or fraudulently misapply anything therein ;

shall, on conviction by court martial, be liable to imprisonment for a term not exceeding two years or to any less punishment provided by this Act.

**58. Any person who—**

Looting.

(a) steals from, or with intent to steal searches, the person of anyone killed or wounded in the course of warlike operations ; or

(b) steals any property which has been left exposed or unprotected in consequence of warlike operations ; or

(c) takes otherwise than for the service of the public any vehicle, equipment or stores abandoned by the enemy,

shall be guilty of looting and liable, on conviction by court martial, to imprisonment or to any less punishment provided by this Act.

*Other Offences in respect of Ships and Aircraft*

**59. Any person who signs a certificate relating to any matter affecting the seagoing or fighting efficiency of any of the Nigerian service ships or vessels or any certificate relating to any of the Nigerian service aircraft or aircraft material without ensuring the accuracy of the certificate shall, on conviction by court martial, be liable to imprisonment for a term not exceeding two years or to any less punishment provided by this Act.**

Inaccurate certification of ships, etc.

**60. Any person who, being in command of any of the Nigerian service ships, vessels or aircraft, without lawful authority—**

Improper carriage of goods.

(a) receives or permits to be received on board the ship, vessel or aircraft any goods or merchandise intended for disposal or delivery by way of trade or business (whether on his own account or on account of any other person), not being merchandise received in the course of salvage ; or

(b) agrees to carry any goods or merchandise on board the ship, vessel or aircraft in consideration of the payment of freight, or demands or receives any payment in respect of such carriage,

shall, on conviction by court martial, be liable to imprisonment for a term not exceeding two years or to any less punishment provided by this Act.

*Malingering and Drunkenness***61. Any person who—**

Malingering.

(a) falsely pretends to be suffering from sickness or disability ; or

(b) injures himself with intent thereby to render himself unfit or temporarily unfit for service, or causes himself to be injured by any other person with that intent ; or

(c) injures any other person subject to service law, at the instance of that other person, with intent thereby to render that other person unfit or temporarily unfit for service ; or

(d) with intent to render or keep himself unfit or temporarily unfit for service does or fails to do anything (whether at the time of the act or omission he is in hospital or not) whereby he produces, or prolongs or aggravates, any sickness or disability,

shall be guilty of malingering and shall, on conviction by court martial, be liable to imprisonment for a term not exceeding two years or to any less punishment provided by this Act.

**62.—(1) Any person who is guilty of drunkenness, whether on duty or not, shall, on conviction by court martial, be liable to imprisonment for a term not exceeding two years or to any less punishment provided by this Act :**

Drunkenness.

Provided that where the offence is committed by a rating not on active service or on duty, the sentence imposed shall not exceed imprisonment for a period of six months.

(2) For the purpose of this section a person is guilty of drunkenness if owing to the influence of alcohol or any drug, whether alone or in combination with any other circumstances, he is unfit to be entrusted with his duty or with any duty which he may be called upon to perform, or behaves in a disorderly manner or in any manner likely to bring discredit to the armed forces of Nigeria.

### *Offences relating to Property*

Misapplication and destruction of public and service property.

63. Any person who—

(a) steals or fraudulently misapplies any public or service property, or is concerned in or connives at the stealing or fraudulent misapplication of any public or service property ; or

(b) receives or retains any public or service property knowing or having reason to believe it to have been stolen or to have been fraudulently misapplied ; or

(c) wilfully damages, or is concerned in the wilful damage of, any public or service property ; or

(d) by wilful neglect causes damage to any public or service property, shall, on conviction by court martial, be liable to imprisonment or to any less punishment provided by this Act.

Loss and waste of public and service property.

64. Any person who—

(a) loses any public or service property of which he has the charge or which has been entrusted to his care or which forms part of property of which he has the charge or which has been entrusted to his care ; or

(b) by negligence damages any public or service property of which he has the charge or which has been entrusted to his care or which forms part of the property of which he has the charge or which has been entrusted to his care ; or

(c) by negligence causes damage to any public or service property ; or

(d) fails to take proper care of any animal or bird used in the public service which is in his charge ; or

(e) makes away (by pawning or in any other way) with any naval decoration granted to him or any clothing, arms, ammunition or other equipment issued to him for his use for naval purposes, shall, on conviction by court martial, be liable to imprisonment for a term not exceeding two years or to any less punishment provided by this Act :

Provided that it shall be a defence for any person charged under paragraph (a) of this section with losing any property that he took reasonable steps for the care and preservation thereof.

Offences in relation to property of members of forces.

65. Any person who—

(a) steals or fraudulently misapplies any property belonging to a person subject to service law, or is concerned in or connives at the stealing or fraudulent misapplication of any such property ; or

(b) receives or retains any such property knowing or having reason to believe the same to have been stolen or to have been fraudulently misapplied ; or

(c) wilfully damages, or is concerned in the wilful damage of, any property belonging to a person subject to service law,

shall, on conviction by court martial, be liable to imprisonment for a term not exceeding two years or to any less punishment provided by this Act.

*Offences relating to and by Persons in Custody*

66.—(1) Any person who, when an officer or rating or other person subject to naval law is under arrest—

Irregular  
arrest and  
confinement.

(a) unnecessarily delays the investigation of allegations against that officer, rating or other person or, as the case may be, his trial ; or

(b) fails to release, or effect the release of, that officer, rating or other person when it is his duty to do so, shall be guilty of an offence against this section.

(2) Where any person (elsewhere in this section referred to as "the prisoner") is committed to the custody of any provost officer or other officer, or any petty officer, and the person so committing the prisoner fails without reasonable cause to deliver—

(a) at the time of the committal, or

(b) if it is not practicable so to do at the time of the committal, then within twenty-four hours thereafter, to the person to whose custody the prisoner was committed, a report in writing signed by himself of the offence which the prisoner is alleged to have committed, he shall be guilty of an offence against this section.

(3) Where a prisoner is committed to the charge of any person who is in command of a guard, and the guard commander fails without reasonable excuse to give to the officer to whom it is his duty to report, as soon as may be after he is relieved from his guard and any further duty or, if he is not sooner relieved, within twenty-four hours after the committal—

(a) a written statement containing so far as known to him, the name of the prisoner with particulars of the alleged offences, and the name and rank or other description of the officer or other person by whom the prisoner is alleged to have committed the offence ; and

(b) (if he has received it) the report required by subsection (2) of this section,  
he shall be guilty of an offence against this section.

(4) Any person guilty of an offence against this section shall, on conviction by court martial, be liable to imprisonment for a term not exceeding two years or to any less punishment provided by this Act.

67.—(1) Any person who wilfully allows to escape any person who is committed to his charge, or whom it is his duty to guard, shall, on conviction by court martial, be liable to imprisonment or to any less punishment provided by this Act.

Permitting  
escape and  
unlawful  
release of  
prisoners.

(2) Any person who—

(a) without proper authority releases any person who is committed to his charge ; or

(b) without reasonable excuse allows to escape any person who is committed to his charge, or whom it is his duty to guard, shall, on conviction by court martial, be liable to imprisonment for a term not exceeding two years or to any less punishment provided by this Act.

Resisting arrest.

68.—(1) Any person who, being concerned in any quarrel or disorder, refuses to obey any officer who orders him into arrest, or strikes or otherwise uses violence to, or offers violence to, any such officer, shall be guilty of an offence against this section whether or not the officer is his superior officer.

(2) Any person who strikes or otherwise uses violence to, or offers violence to, any person whose duty it is to apprehend him or in whose custody he is shall be guilty of an offence against this section.

(3) Any person guilty of an offence against this section shall, on conviction by court martial, be liable to imprisonment for a term not exceeding two years or to any less punishment provided by this Act.

Escape from confinement.

69. Any person who escapes from arrest, prison or other lawful custody (whether naval custody or not) shall, on conviction by court martial, be liable to imprisonment for a term not exceeding two years or to any less punishment provided by this Act.

#### *Offences in relation to Courts Martial and Civil Authorities*

Offences in relation to courts martial.

70.—(1) Any person who—

(a) having been duly summoned or ordered to attend as a witness before a court martial, fails to comply with the summons or order ; or

(b) refuses to swear an oath or make an affirmation when duly required by a court martial to do so ; or

(c) refuses to produce any document in his custody or under his control which a court martial has lawfully required him to produce ; or

(d) when a witness, refuses to answer any question which a court martial has lawfully required him to answer ; or

(e) wilfully insults any person, being a member of a court martial or a witness or any other person whose duty it is to attend on or before the court, while that person is acting as a member thereof or is so attending, or wilfully insults any such person as aforesaid while that person is going to or returning from the proceedings of the court ;  
or

(f) wilfully interrupts the proceedings of a court martial, or otherwise misbehaves before the court, shall, on conviction by court martial, other than the court in relation to which the offence was committed, be liable to imprisonment for a term not exceeding two years or to any less punishment provided by this Act.

(2) Notwithstanding anything in subsection (1) of this section, where an offence against paragraph (e) or paragraph (f) of that subsection is committed in relation to any court martial held in pursuance of this Act that court, if of opinion that it is expedient that the offender should

be dealt with summarily by the court instead of being brought to trial before another court martial, may by order under the hand of the president of the court order the offender to be imprisoned for a period not exceeding twenty-one days.

(3) References in paragraphs (a) to (f) of subsection (1) of this section to a court martial shall include references to a court martial held in pursuance of service law.

71.—(1) Any person who, having been duly sworn as a witness or as an interpreter in proceedings before a court martial or before any board or person having power to administer an oath under service law, makes a statement material in those proceedings knowing it to be false or recklessly without belief in its truth shall, on conviction by court martial, be liable to imprisonment for a term not exceeding two years or to any less punishment provided by this Act.

False evidence.

(3) A person shall not be liable to be convicted of an offence against this section upon the evidence, sworn or unsworn, of one witness alone as to the truth or untruth of any statement alleged to be false.

72. Any person who at any place either within or outside Nigeria prevents or obstructs—

Obstruction of police officer arresting officer or rating.

(a) the execution by a police officer of a warrant for the arrest of a person subject to service law who has committed or is suspected of having committed an offence punishable on conviction by a civil court; or

(b) the arrest of a person subject to service law by a police officer acting in the exercise of his powers of arrest without warrant, shall, on conviction by court martial, be liable to imprisonment for a term not exceeding two years or to any less punishment provided by this Act.

#### *Miscellaneous Offences*

73.—(1) Any person who without authority discloses, by any means whatsoever, information which is or purports to be information useful to an enemy shall, on conviction by court martial, be liable to imprisonment for a term not exceeding two years or to any less punishment provided by this Act.

Injurious disclosures.

(2) In this section the expression "information useful to an enemy" means information as to any matter such that information as to it would or might be directly or indirectly useful to an enemy, and in particular (but without prejudice to the generality of the foregoing provisions of this subsection) information as to any matter falling within the following paragraphs, being a matter such that information as to it would or might be useful as aforesaid, that is to say—

(a) the number, description, armament, equipment, disposition, movement or condition of any of the armed forces of Nigeria or of any forces co-operating therewith, or any of Nigerian ships or aircraft or of the ships or aircraft of any such co-operating force; or

(b) any operations or projected operations of any of such forces, ships or aircraft as aforesaid; or

(c) any code, cipher, call sign, password or countersign; or

(d) any measures for the defence or fortification of any place on behalf of Nigeria; or

(e) the number, description or location of any prisoners of war; or

(f) munitions of war.

Making of false statements on enlistment.

74. Any person who, when before a recruiting officer for the purpose of being attested in pursuance of Part III of this Act has knowingly made a false answer to any question contained in the attestation paper and put to him by or by the direction of the recruiting officer shall, on conviction by court martial, if he is subject to naval law, be liable to imprisonment for a term not exceeding three months or to any less punishment provided by this Act.

Scandalous conduct of officer.

75. Every officer who behaves in a scandalous manner, unbecoming the character of an officer and a gentleman, shall, on conviction by court martial, be dismissed with disgrace from the armed forces of Nigeria.

Ill-treatment of officers or ratings of inferior rank.

76. If—

- (a) any officer strikes or otherwise ill-treats any officer subject to serve law of inferior rank or less seniority or any rating subject to service law ; or
- (b) any petty officer strikes or otherwise ill-treats any person subject to service law, being a rating of inferior rank or less seniority, any such officer shall, on conviction by court martial, be liable to imprisonment for a term not exceeding two years or to any less punishment provided by this Act.

Disgraceful conduct.

77. Any person who is guilty of disgraceful conduct of a cruel, indecent or unnatural kind shall, on conviction by court martial, be liable to imprisonment for a term not exceeding two years or to any less punishment provided by this Act.

False accusation.

78. Any person who—

- (a) makes an accusation against any officer or rating subject to service law, knowing it to be false or recklessly without belief in its truth ; or
- (b) in making a complaint where he thinks himself wronged, makes a statement affecting the character of an officer or rating subject to service law, knowing it to be false or recklessly without belief in its truth, or wilfully suppresses any material facts, shall, on conviction by court martial, be liable to imprisonment for a term not exceeding two years or to any less punishment provided by this Act.

Conduct to prejudice of naval discipline.

79. Any person who is guilty of any conduct or neglect to the prejudice of good order and naval discipline shall, on conviction by court martial, be liable to imprisonment for a term not exceeding two years or to any less punishment provided by this Act.

#### *Attempts and Aiding and Abetting of Naval Offences*

Attempts to commit naval offences.

80. Any person who attempts to commit an offence against any of the foregoing provisions of this Part of this Act shall, on conviction by court martial, be liable to the like punishment as for that offence :

Provided that if the offence is one punishable by death he shall not be liable to any greater punishment than imprisonment.

Aiding and abetting naval offences.

81. Any person who aids, abets, counsels or procures the commission by another person of an offence against any of the provisions of this Act shall be guilty of the like offence and shall be liable to be charged, tried and punished as a principal offender.

*Civil Offences*

82.—(1) Any person who commits a civil offence within the meaning of this Act in Nigeria or elsewhere, shall be guilty of an offence against this section. Civil offences.

(2) For the purposes of the foregoing subsection, the expression "civil offence" means any act or omission punishable as an offence under the penal provisions of any law enacted in or applicable to Nigeria, and "the corresponding civil offence" means the civil offence the commission of which constitutes the offence against this section.

(3) Subject to the next succeeding subsection, a person convicted by court martial of an offence against this section shall—

(a) if the corresponding civil offence is treason or murder be liable to suffer death, and

(b) in any other case, be liable to suffer the punishment which a civil court might award for the corresponding civil offence, if committed anywhere in Nigeria, being a punishment provided by this Act, or such lesser punishment which a civil court could so award, as is so provided.

(4) Where a court other than a court martial may not award a term of imprisonment for a civil offence, a person convicted of a civil offence shall be liable to suffer such punishment, less than dismissal with disgrace in the case of an officer, or discharge with ignominy in the case of a rating, as is prescribed for the civil offence.

(5) Nothing in this section shall be construed to authorise the charging of a person with an offence against this section committed in Nigeria if the corresponding civil offence is treason, murder, manslaughter, treasonable felony or rape; and for the purposes of this subsection where the corresponding civil offence is murder or manslaughter an offence against this section shall be deemed to have been committed at the place of the commission of the act or occurrence of the negligence which caused the death, irrespective of the place of the death.

*Punishments*

83.—(1) The punishments which may be awarded to an officer by sentence of a court martial under this Act are, subject to the limitations hereinafter provided on the powers of certain courts martial, those set out in the following scale; and in relation to an officer, references in this Act to punishments provided by this Act are references to those punishments. Punishment of officers.

(2) The said scale is—

(a) death;

(b) imprisonment;

(c) dismissal with disgrace from the armed forces of Nigeria;

(d) dismissal from the armed forces of Nigeria;

(e) forfeiture of seniority;

(f) a fine of a sum not exceeding the equivalent of ninety days' pay;

(g) severe reprimand or reprimand;

(h) stoppages, where the offence has occasioned any expense, loss or damage.

(3) For the purposes of this Part of this Act, a punishment specified in any paragraph of the said scale shall be treated as less than the punishment specified in the preceding paragraphs, and greater than those specified in the following paragraphs, of the scale.

(4) Save as expressly provided in this Act, not more than one punishment shall be awarded by a court martial for one offence.

(5) Stoppages may be awarded by a court martial either in addition to or without any other punishment.

(6) A severe reprimand or reprimand may be awarded by a court martial in addition to a fine.

(7) Where an officer is sentenced by a court martial to imprisonment, he shall also be sentenced to be dismissed with disgrace from the armed forces of Nigeria :

Provided that if the court martial fails to sentence him to be so dismissed, the sentence of imprisonment shall not be invalid, but shall be deemed to include a sentence of dismissal with disgrace.

Punishment  
of ratings.

84.—(1) The punishment which may be awarded to a rating by sentence of a court martial under this Act are, subject to the limitations hereinafter provided on the powers of certain courts martial, those set out in the following scale ; and in relation to a rating reference in this Act to punishments provided by this Act are references to those punishments.

(2) The said scale is—

(a) death ;

(b) imprisonment ;

(c) dismissal with disgrace from the armed forces of Nigeria ;

(d) dismissal from the armed forces of Nigeria ;

(e) disrating to any rate not lower than that in which the rating was enlisted ;

(f) a fine of a sum not exceeding the equivalent of ninety days' pay ;

(g) in the case of a chief petty officer or petty officer, severe reprimand or reprimand ;

(h) where the offence is desertion ; forfeiture of service ;

(i) stoppages, where the offence has occasioned any expense, loss or damage.

(3) For the purposes of this Part of this Act, a punishment specified in any paragraph of the said scale shall be treated as less than the punishments specified in the preceding paragraphs, and greater than those specified in the following paragraphs, of the scale.

(4) Notwithstanding the provisions of subsections (1) and (2) of this section, a court martial may, where it thinks fit, award any punishment specified in the First Schedule to this Act, being a punishment not already specified in subsection (2) of this section ; and where a court martial awards any such punishment the qualification (if any) specified in the said Schedule in respect of such punishment shall not apply.

(5) Save as expressly provided in this Act, not more than one punishment shall be awarded by a court martial for one offence.

First  
Schedule.

(6) A rating sentenced by a court martial to imprisonment may in addition thereto be sentenced to be discharged with disgrace from the armed forces of Nigeria.

(7) Where any rating is sentenced by a court martial to imprisonment he shall also be sentenced to be disgraced to the rate in which he enlisted :

Provided that if the court martial fails to sentence him to be so disgraced the sentence shall not be invalid but shall be deemed to include a sentence of disgracing.

(8) In the case of a rating, a severe reprimand or reprimand may be awarded by a court martial in addition to a fine.

(9) Stoppages may be awarded by a court martial either in addition to or without any other punishment.

#### Arrest

85.—(1) Any person found committing an offence against any provision of this Act, or alleged to have committed or reasonably suspected of having committed any such offence, may be arrested in accordance with the following provisions of this section.

Power to  
arrest  
offenders

(2) An officer may be arrested by an officer subject to service law of superior rank, or, if engaged in a quarrel or disorder, by such an officer of any rank.

(3) A rating may be arrested by an officer or another rating subject to service law but no rating shall be arrested under this subsection except by a person of superior rank.

(4) A provost officer, or any officer, warrant officer, non-commissioned officer, rating, soldier or airman subject to service law lawfully exercising authority under a provost officer or on his behalf, may arrest any officer or rating ; but no officer shall be arrested under this subsection except on the order of another officer.

(5) The power of arrest given to any person by this section may be exercised either personally or by ordering into arrest the person to be arrested or by giving orders for that person's arrest.

86.—(1) The allegations against any person who is under arrest shall be duly investigated without unnecessary delay, and as soon as may be, either proceedings shall be taken for punishing his offence or he shall be released from arrest.

Provisions  
for avoiding  
delay after  
arrest.

(2) If any person taken into naval custody remains under arrest for a longer period than eight days without a court martial for his trial being assembled, a special report on the necessity for further delay shall be made by his commanding officer as may be prescribed and a similar report shall be made not later than every eight days thereafter (whichever event happens first) until a court martial is assembled or the offence is dealt with summarily or the person is released from arrest:

Provided that in the case of a person on active service compliance with this subsection shall be excused in so far as it is not reasonably practicable having regard to the exigencies of naval operations.

(3) For the purposes of subsection (1) of section sixty-six, the question whether there has been unnecessary delay in the investigation of allegations against a person under arrest shall be determined without regard to the provisions of subsection (2) of this section.

*Investigation of and Summary Dealing with Charges*

Investigation  
of charges by  
commanding  
officer.

87. Before an allegation against a person that he has committed an offence against any provision of this Part of this Act is further proceeded with, the allegation shall be reported in the form of a charge to the commanding officer, where the person charged is an officer, or to the officer of the watch, or the officer of the day or the executive officer, as the case may be, where the person charged is a rating, and the officer to whom the charge is reported shall investigate the charge in the prescribed manner.

Summary  
trial of  
officers.

88.—(1) If an officer of the navy or of the reserve below the rank of commander is charged with an offence to which this section applies, the commander may, if it appears to him that the offence is not of such a nature as to necessitate trial by court martial, and subject to the provisions of this section and of any orders made thereunder, deal with the charge summarily. If he records a finding of guilty, he may award one or more of the following punishments, that is to say—

(a) a fine not exceeding twenty-five days' pay ;

(b) severe reprimand or reprimand ;

(c) stoppages, where the offence has occasioned any expense, loss or damage.

(2) This section applies to any offence triable by court martial under this Act other than offences under the following provisions of this Act, that is to say—

(a) sections thirty-three, thirty-four, thirty-five, thirty-six, thirty-nine, forty-two, forty-three, fifty-six, fifty-seven, fifty-eight, sixty-three, seventy-three, seventy-seven, and eighty-two ;

(b) sections eighty and eighty-one, so far as they are applicable to an offence under any of the provisions mentioned in paragraph (a) of this subsection.

(3) Notwithstanding anything in subsection (1) of this section, where the commander has determined that the person charged is guilty and if the charge is dealt with summarily will award a fine or stoppages, the commander shall not record a finding until after affording such person an opportunity of electing to be tried by court martial ; and if such person so elects, the commander shall not record a finding but shall take the prescribed steps with a view to the charge being tried by court martial.

(4) The commander may by order direct that the powers conferred upon him by this Act to investigate charges against officers and try and punish officers summarily may be exercised by officers not below the rank of captain.

Summary  
trial of  
ratings.  
First  
Schedule.

89.—(1) Subject to the provisions of this section, a rating who is charged with an offence to which this section applies may be summarily tried and punished to the extent permitted and in accordance with the First Schedule to this Act by the officer in command of the ship or establishment to which the rating belongs either at the time of the commission of the offence or at the time of the trial thereof.

(2) Where an officer holding a post specified in the First Schedule has been absent from his post on duty or approved leave for more than ninety-six hours continuously or has otherwise ceased to carry out his duties through sickness or any other cause, any officer temporarily authorised to carry out the duties of the post may while so authorised exercise the same powers of punishment as may be exercised by the substantive holder of the post, and the said First Schedule shall be construed accordingly.

(3) The power conferred by subsection (1) of this section on the officer in command of a ship or naval establishment may, subject to any rules made under this Act, be exercised—

(a) in respect of persons on board a single tender or boat which is absent from the ship or establishment on detached service, by the officer in command of that tender or boat ;

(b) in respect of persons on board one of two or more tenders or boats which are absent as aforesaid on detached service in company or acting together, by the officer in immediate command of those tenders or boats ; and

(c) in respect of other persons absent from the ship or establishment on detached service either on shore or elsewhere, by the officer in immediate command of those persons.

(4) The power conferred on any officer by subsection (1) or subsection (3) of this section may, subject to such conditions as may be prescribed be delegated to any officer not below the rank of lieutenant or corresponding rank.

(5) The President may by order amend the First Schedule.

(6) This section applies to any offence triable by court martial under this Act, other than an offence punishable by sentence of death.

90.—(1) Any charge not dealt with summarily shall after investigation be remanded for trial by court martial.

(2) Notwithstanding anything in the foregoing provisions of this section, where an officer has investigated a charge he may dismiss the charge if he is of the opinion that it ought not to be proceeded with.

(3) References in this Act to dealing summarily with a charge are references to the taking by the officer authorised, as the case may require, of the following action, that is to say, determining whether the accused is guilty, dismissing the charge or recording a finding of guilty accordingly, and awarding punishment.

#### *Courts Martial : General Provisions*

91. A court martial may try any person subject to naval law under this Act for any offence under Part IV of this Act and award any punishment authorised by this Act for that offence and, subject to the provisions of subsections (4) and (5) of section eighty-two, a court martial shall have jurisdiction to try any such offence whether committed within Nigeria or elsewhere.

92.—(1) The commander shall have the power to convene a court martial.

(2) Where the commander is absent from his post on duty or approved leave for more than ninety-six hours continuously or has otherwise ceased to carry out his duties through sickness or any other cause, any officer, temporarily authorised to carry out the duties of the commander, shall have the power to convene a court martial.

Charges to be dealt with summarily of by court martial.

Jurisdiction of courts martial.

Officers having power to convene courts martial.

(3) The senior officer of a detached unit or squadron may be authorised by the board to order a court martial in special circumstances.

Composition  
of courts  
martial.

93.—(1) A court martial shall consist of not less than three nor more than nine officers, being officers of or seconded to the navy and subject to service law who are of or above the rank of lieutenant in the navy.

(2) An officer shall not be appointed to be a member of a court martial unless he has held a commission in any of the armed forces of Nigeria for a period of not less than two years or for periods amounting in the aggregate to not less than two years.

(3) The members of a court martial and such spare members as the convening officer considers appropriate for the purpose of filling vacancies, shall be nominated by the convening officer.

(4) The president of a court martial shall not be below the rank of commander.

(5) A court martial for the trial of a commander shall include at least two members in addition to the president, who are not below the rank of commander.

(6) If a court martial is to be convened at any place where in the opinion of the convening officer the necessary number of naval officers having suitable qualifications is not available to form the court, and cannot be made available with due regard to the circumstances, the convening officer may, with the consent of the proper military or air force authority, appoint any military or air force officer as president in lieu of a naval officer or as any other member of the court in lieu of or in addition to a naval officer or officers :

Provided that no military or air force officer shall be qualified to act in relation to a court martial unless he is of corresponding rank to that which would have been required in the case of a naval officer and has held a commission in any of the armed forces of Nigeria for the like period or periods as would have been so required.

(7) Where the officer convening any court martial appoints an officer not being a naval officer as president or any other member of the court, being of opinion that the necessary number of naval officers having suitable qualifications is not available to form the court and cannot be made available with due regard to the circumstances, the order convening the court martial shall contain a statement of the said opinion, and that statement shall be conclusive.

(8) The officer who convenes a court martial shall not be a member of that court martial ; and no court martial shall consist of officers all of whom belong to the same ship or naval establishment.

(9) An officer who, at any time between the date on which the accused was charged with the offence and the date of the trial, has investigated the charge against the accused, or who under service law has held, or acted as one of the persons holding, an inquiry into matters relating to the subject matter of the charge against the accused, shall not sit as a member of a court martial or act as judge advocate at such a court martial.

(10) A court martial for the trial of an officer shall consist of at least five officers.

(11) A court martial consisting of less than five officers shall not award any punishment higher in the scale of punishments than imprisonment for two years.

(12) Unless it consists of at least five officers, a court martial shall not try any offence for which the maximum or only punishment is death.

94. Without prejudice to the powers conferred by the President on the Judge Advocate General, the appointment of a judge advocate to act in any court martial may, failing the making thereof by or on behalf of the Judge Advocate General, be made by the convening officer.

Appointment  
of judge  
advocate.

95.—(1) A court martial shall be held on board such of the Nigerian ships or vessels, or such premises on shore, whether within or without Nigeria as may be specified in the order convening the court.

Place and  
time for sit-  
ting of courts  
martial.

(2) If it appears to a court martial to be expedient in the interests of justice the court may be adjourned, either generally or for the purpose of any part of the proceedings, to any other ship, vessel or place and shall, if so required by the convening officer, be adjourned to any other ship, vessel or place appointed by that officer.

(3) Without prejudice to the provisions of subsection (2) of this section, a court martial may, if it appears to the court that an adjournment is desirable for any reason, be adjourned for such period as the court thinks fit :

Provided that except with the consent of the accused and the prosecutor the period for which the court may be adjourned under this subsection shall not on any occasion exceed six days.

(4) Subject to the provisions of this section, a court martial shall, unless prevented by weather or other unavoidable cause, sit from day to day until the court has arrived at a finding and, in the case of a conviction, until sentence is pronounced ; but the court shall not sit on a Sunday, or any day that is a public holiday, unless, in the opinion of the court or of the convening officer, exigencies of the service make it necessary to do so.

96.—(1) Where, whether before or after the commencement of the trial, it appears to the convening officer necessary or expedient in the interests of the administration of justice that a court martial should be dissolved, the convening officer may by order dissolve the court martial.

Dissolution  
of court  
martial.

(2) Without prejudice to the generality of subsection (1) of this section, if after the commencement of the trial a court martial is, by reason of the death of one of the members or for any other reason, reduced below the legal minimum, it shall be dissolved.

(3) The proceedings of a court martial shall be valid notwithstanding the absence of one or more of the members other than the president, so long as the number of members present throughout the proceedings is not reduced below the legal minimum :

Provided that a member of the court who has been absent for any time during a sitting shall take no further part in the proceedings.

(4) If after the commencement of the trial the president dies or is otherwise unable to attend and the court is not reduced below the legal minimum, then—

(a) if the senior member of the court is of the rank of lieutenant-commander or corresponding rank or is of higher rank, the convening officer may appoint him president and the trial shall proceed accordingly ; but

(b) if he is not, the court shall be dissolved.

(5) Without prejudice to the generality of subsection (1) of this section, if after the commencement of the trial it is represented to the convening officer that owing to the sickness or other incapacity of the accused it is impracticable having regard to all the circumstances to continue the trial within a reasonable time, the convening officer may dissolve the court.

(6) Where a court martial is dissolved under the foregoing provisions of this section the accused may be tried by another court martial.

Challenges  
by accused.

97.—(1) An accused about to be tried by a court martial shall be entitled to object, on any reasonable grounds, to any member of the court, whether appointed originally or in lieu of another officer.

(2) For the purpose of enabling the accused to avail himself of the right conferred by subsection (1) of this section the names of the members of the court shall be read over in the presence of the accused before they are sworn, and he shall be asked whether he objects to any of those officers.

(3) Every objection made by an accused to any officer shall be considered by the other officers appointed members of the court.

(4) If objection is made to the president and not less than one-third of the other members of the court allow it, the court shall adjourn and the convening officer shall appoint another president.

(5) If objection is made to a member of the court other than the president and not less than one-half of the members entitled to vote allow it, the member objected to shall retire and the vacancy may, and if otherwise the number of members would be reduced below the legal minimum shall, be filled in the prescribed manner by another officer.

Admini-  
stration of  
oaths.

98.—(1) An oath shall be administered separately to every member of a court martial and to any person in attendance on a court martial as judge advocate, the clerk of the court, officer under instruction, shorthand writer or interpreter.

(2) Every witness before a court martial shall be examined on oath :

Provided that where any child called as a witness does not in the opinion of the court understand the nature of an oath, his evidence may be received, though not given on oath, if in the opinion of the court he is possessed of sufficient intelligence to justify the reception of the evidence and understands the duty of speaking the truth, so however that, where the evidence is given on behalf of the prosecution, the accused shall not be liable to be convicted upon such evidence alone unless it is corroborated by some other material evidence in support thereof implicating the accused.

(3) A person shall be permitted to make a solemn affirmation instead of taking an oath under this section—

(a) if he objects to being sworn, and states as the grounds of his objection either that he has no religious belief or that the taking of an oath is contrary to his religious belief ; or

(b) if it is not reasonably practicable to administer an oath to him in the manner appropriate to his religious belief.

(4) An oath or affirmation required to be administered under this section shall be in the form prescribed by the Oaths Act, 1963, or if no form is so prescribed, as near thereto as may be in any particular case, and shall be administered accordingly.

99.—(1) Subject to the provisions of this section, a court martial shall sit in open court and in the presence of the accused.

Courts martial to sit in open court.

(2) Nothing in subsection (1) of this section shall affect the power of a court martial to sit in camera on the ground that it is necessary or expedient in the interests of the administration of justice to do so; and without prejudice to that power a court martial may order that, subject to any exceptions the court may specify, the public shall be excluded from all or any part of the proceedings of the court if it appears to the court that any evidence to be given or statement to be made in the course of the proceedings or that part, as the case may be, might otherwise lead to the disclosure of any information which would or might be directly or indirectly useful to an enemy.

(3) A court martial shall sit in closed court while deliberating on its findings or sentence on any charge.

(4) A court martial may sit in closed court on any other deliberation amongst the members.

(5) Where a court martial sits in closed court no person shall be present except the members of the court and such other persons as may be prescribed.

100.—(1) Subject to the provisions of this section, every question to be determined on trial by court martial shall be determined by a majority of the votes of the members of the court.

Decisions of courts martial.

(2) In the case of an equality of votes on the finding, the court shall acquit the accused.

(3) A finding of guilty where the only punishment which the court is empowered to award is death shall not have effect unless it is reached with the concurrence of all members of the court; and where there is such a finding but no such concurrence, the court shall be dissolved and the accused may be tried by another court.

(4) Where the accused is found guilty and the court has power to sentence him either to death or to some less punishment, sentence of death shall not be passed without the concurrence of all the members of the court.

(5) In the case of an equality of votes on the sentence or on any question arising after the commencement of a trial, except the findings, the president shall have a second or casting vote.

101.—(1) Without prejudice to the provisions of section ninety-nine of this Act the finding of a court martial on each charge shall be announced in open court; and where the finding of that court is one of guilty the finding shall be, and be announced as being, subject to confirmation.

Finding and sentence.

(2) The sentence of a court martial together with any recommendation to mercy shall be announced in open court, and shall be, and be announced as being, subject to confirmation.

102.—(1) Any person charged before a court martial with an offence under this Act may, on failure of proof of the offence having been committed under circumstances involving a higher degree of punishment, be found guilty of the offence as having been committed under circumstances involving a less degree of punishment.

Power to convict of offence other than that charged.

(2) Any person charged before a court martial with any offence may be found guilty of attempting to commit that offence.

(3) Any person charged before a court martial with attempting to commit an offence may be convicted on that charge notwithstanding that it is proved that he actually committed the offence.

(4) Where a person is charged before a court martial under section eighty-two of this Act in respect of attempting to commit a civil offence, he may be convicted on that charge notwithstanding that it is proved that he actually committed the civil offence.

(5) Where a person is charged before a court martial with an offence against section eighty-two of this Act and the corresponding civil offence is one in proceedings for which, if he had been tried by a civil court for committing the offence in Nigeria, he might have been found guilty of another civil offence, then if the court finds that he has committed that other civil offence he may be convicted of an offence against the said section eighty-two in respect of the commission of that other civil offence.

(6) Any person charged before a court martial with an offence specified in the first column of the Second Schedule to this Act may be found guilty of an offence specified in relation thereto in the second column of that schedule.

Second  
Schedule.

Rules of  
evidence.

103.—(1) Unless otherwise prescribed, the rules of evidence to be observed in proceedings before a court martial shall, for the avoidance of doubt, be the same as those observed in the High Court of Lagos; and accordingly no person shall in proceedings before a court martial be required to answer questions or produce documents which he could not be required to answer or produce in similar proceedings before that Court.

(2) Notwithstanding anything in the last foregoing subsection, a statutory declaration shall, in a trial by court martial, be admissible as evidence of the fact stated therein in a case where and to the extent to which oral evidence to the like effect would be admissible in that trial; but no statutory declaration shall be admitted in evidence—

(a) if such declaration is tendered on behalf of the prosecution, unless a copy of such declaration has not less than seven days before the commencement of the trial been served on the accused; or

(b) if such declaration is tendered on behalf of the defence, unless a copy of such declaration has not less than seven days or such lesser period as the commanding officer may allow before the commencement of the trial been served on the commanding officer of the accused; or

(c) in any case, if, not later than three days before the commencement of the trial or within such extended time as the court martial may in the circumstances of the case allow, notice in the prescribed form is served on the accused or, as the case may be, the commanding officer of the accused, requiring oral evidence to be given in substitution for that contained in the statutory declaration; or

(d) in any case, if the court martial is of opinion that it is desirable in the interests of justice for oral evidence to be given.

(3) Every court martial shall take judicial notice of all matters of notoriety, including matters within the general service knowledge of the court and of all other matters of which judicial notice would be taken in the High Court of Lagos.

104. A witness before a court martial and any other person required to attend such court shall have and be entitled to the same immunities and privileges as are accorded to witnesses in the High Court of Lagos.

Privileges of witnesses and others at courts martial.

105.—(1) Any person, whether subject to this Act or not, who is required to give evidence before a court martial may be summoned by notice in writing given by order of the convening officer.

Summoning of witnesses.

(2) Any person not subject to this Act who attends a court martial in pursuance of a notice under this section shall be entitled to receive such expenses of his attendance as may be prescribed.

106.—(1) Where in Nigeria any person other than a person subject to this Act—

Offences by civilians in relation to courts martial.

(a) having been duly summoned to attend as a witness before a court martial, fails to comply with the summons ; or

(b) refuses to swear on oath when duly required by a court martial to do so ; or

(c) refuses to produce any document in his custody or under his control which a court martial has lawfully required him to produce ; or

(d) when a witness, refuses to answer any question which a court martial has lawfully required him to answer ; or

(e) wilfully insults any person, being a member of a court martial or any other person whose duty it is to attend on or before a court martial, while that person is acting as a member thereof or is so attending, or wilfully insults any such person as aforesaid while that person is going to or returning from the proceedings of a court martial ; or

(f) wilfully interrupts the proceedings of a court martial or otherwise misbehaves before the court ; or

(g) does any other thing which would, if the court martial had been a court of law having power to commit for contempt, have been contempt of that court,

the president of the court martial may certify the offence of that person under his hand to the High Court having jurisdiction in that part of Nigeria where the offence is alleged to have been committed or in the place where the offender is to be found, and the High Court may thereupon inquire into the alleged offence and after hearing witnesses (if any) and taking any statement that may be offered in defence, punish or take steps for the punishment of that person in like manner as if he had been guilty of contempt of the court to which the offence is certified.

(2) A person shall not be dealt with under this section in respect of failure to comply with a summons requiring him to attend as a witness before a court martial unless any expenses to which he is entitled under this Act in respect of his attendance have been paid or tendered :

Provided that for the purposes of this subsection—

(a) the tender of a warrant or voucher entitling any person to travel shall be deemed to constitute tender of his expenses in respect of any travelling authorised by the warrant or voucher ; or

(b) the tender of a written undertaking on behalf of the board to defray at the trial any other expenses to which such a person may be entitled under this Act in respect of his attendance shall be deemed to constitute tender of those expenses.

(3) In this section "court martial" means a court martial held under service law.

*Confirmation, Revision and Review of Proceedings of  
Courts Martial*

Confirmation  
of proceed-  
ings of court  
martial.

107.—(1) Where a court martial finds the accused guilty of any charge, the record of the proceedings of the court martial shall be transmitted to a confirming authority for confirmation of the finding and sentence of the court on that charge.

(2) Until it is so confirmed, the finding of guilty or, as the case may be, the sentence of a court martial, shall not be treated as the finding or sentence of such court; but nothing in this subsection shall be construed to prohibit the keeping of the accused in custody pending confirmation or revision of the finding or sentence or the consideration of any petition under this Act.

Petitions  
against find-  
ing or  
sentence.

108. At any time after a court martial has sentenced the accused, but not later than the prescribed time after promulgation of confirmation, the accused may, in the prescribed manner, present a petition against the finding or the sentence or both.

Revision of  
findings of  
court  
martial.

109.—(1) A confirming authority may direct that a court martial shall revise any finding of guilty come to by the court in any case where it appears to him—

(a) that the finding was against the evidence; or

(b) that some question of law determined at the trial and relevant to the finding was wrongly determined.

(2) Any such direction shall be accompanied by the necessary directions for the reassembly of the court, and shall contain a statement of the reasons for the direction.

(3) On any revision of a finding the court shall reconsider the finding, and (unless the court adheres thereto) may substitute therefor either a finding of not guilty or any other finding to which the court could originally have come at the trial in lieu of the finding under revision.

(4) On any such revision the court shall not have power to receive further evidence.

(5) Where on any such revision the court either adheres to the original finding or substitutes therefor a finding of guilty of another offence, or of the same offence in different circumstances, the court may substitute a different sentence for the original sentence:

Provided that the court shall not have power to substitute a sentence of a punishment greater than the punishment or the greatest of the punishments awarded by the original sentence, or to substitute a sentence which in the opinion of the court is more severe than the original sentence

(6) The confirming authority shall not have power to direct the revision of any substituted finding of the court on a previous direction of a confirming authority, or the revision of the original finding if adhered to by the court on such a previous direction; but save as aforesaid this Act shall apply to the proceedings of the court on any such revision (other than the requirement of announcement in open court) as it applies to their deliberation on the original finding or sentence, and any substituted finding or sentence shall be treated for all purposes as an original finding or sentence of the court.

110.—(1) Subject to the provisions of section one hundred and nine and to the following provisions of this section, a confirming authority shall deal with the finding or sentence of a court martial—

Powers of  
confirming  
authority.

(a) by withholding confirmation, if of the opinion that the finding of the court martial is unreasonable or cannot be supported, having regard to the evidence or to the fact that it involves a wrong decision on a question of law or that on any other grounds there was a miscarriage of justice; or

(b) by confirming the finding or sentence; or

(c) by referring the finding or sentence, or both, for confirmation to a higher confirming authority.

(2) Where a confirming authority is of the opinion that the facts of the case as considered by the court martial would have justified a finding of guilty by that court on other grounds, the confirming authority may, instead of withholding confirmation of the finding, substitute a finding of guilty on those other grounds and direct whether the punishment should be remitted in whole or in part or be commuted under the provisions of subsection (4) of this section.

(3) Where it appears to a confirming authority that a sentence of a court martial is invalid, the confirming authority may, instead of withholding confirmation of the sentence substitute therefor a proper sentence of any punishment which might have been awarded by the court, not exceeding or, in the opinion of the confirming authority, more severe than that awarded by the court martial.

(4) If the confirming authority confirms the sentence of a court martial the confirming authority may—

(a) remit in whole or in part any punishment awarded by the court martial, or

(b) commute any punishment so awarded for such other and lesser punishment or punishments as may be prescribed by this Act.

(5) A finding or sentence substituted by the confirming authority, or any sentence having effect after the confirming authority has remitted or commuted punishment, shall be treated for all purposes as a finding or sentence of the court duly confirmed.

(6) The confirmation of a finding or sentence shall not be deemed to be completed until the finding or sentence has been promulgated; and in the event of any such substitution, remission or commutation as aforesaid, the finding or sentence shall be promulgated as it has effect after the substitution, remission or commutation.

(7) Where the confirming authority withholds confirmation under this section, notice thereof shall be promulgated, and it shall have effect as from the date of such promulgation.

Confirming  
authorities.

111.—(1) Subject to the provisions of this section, the following persons shall have power to confirm the finding and sentence of any court martial, that is to say—

(a) the officer who convened the court martial or any officer superior in command to that officer ; or

(b) the successor of any such officer or superior officer, or any person for the time being exercising the functions of any such officer or superior officer ; or

(c) any officer appointed by the board to act as confirming authority in default of any officer under paragraphs (a) and (b) of this subsection whether for the particular case or for a specified number of cases.

(2) The following persons shall not have power to confirm the finding or sentence of a court martial, that is to say—

(a) any officer who was a member of the court martial ; or

(b) any officer who, as commanding officer of the accused, investigated the allegations against him or who is for the time being the commanding officer of the accused ; or

(c) any officer who, as appropriate superior authority, investigated the allegations against the accused.

Death  
sentence to  
be approved.

112. A sentence of death passed by a court martial shall not be carried into effect unless approved by the President.

Review of  
findings and  
sentences of  
court  
martial.

113.—(1) The finding or sentence of a court martial as duly confirmed by a confirming authority may be reviewed,—

(a) by a reviewing authority consisting of—

(i) the board or (so far as the delegation extends) any officer to whom the powers of the board as reviewing authority or any of those powers may be delegated, or

(ii) any officer superior in rank to the confirming authority ; or

(b) in proper case on appeal to or after leave to appeal has been granted by a court of competent jurisdiction ;

and where a case is taken on appeal, the powers of a reviewing authority under paragraph (a) of this subsection, shall cease.

(2) If after confirmation of a finding or sentence a petition under section one hundred and eight of this Act is duly presented against the finding or the sentence, or both as the case may be, the finding or sentence shall, subject to the provisions of this section, be reviewed as soon as may be after the presentation of the petition and consideration of its contents.

(3) Where a finding or sentence is reviewed under this section the reviewing authority or the court, as the case may require, may—

(a) to the extent that the review is of a finding, quash the finding and, if the sentence relates only to the finding quashed, the sentence ; or

(b) in any case, exercise the like powers of substituting findings, or valid sentences for invalid sentences, or of remitting or commuting punishment as are conferred on a confirming authority under this Act, and any substituted finding or sentence, or sentence having effect after the remission or commutation of punishment, shall be treated for all purposes as a sentence of the court martial duly confirmed.

(4) Any finding or sentence reviewed under this section shall be promulgated by a reviewing authority and shall have effect as from the date of such promulgation.

114.—(1) Sentences of imprisonment passed by courts martial may be reconsidered by the board and if on any such reconsideration it appears that the conduct of the offender since his conviction has been such as to justify remission of the sentence, whether in part or in whole, it may be remitted accordingly.

Reconsideration of sentences of imprisonment.

(2) The power to reconsider a sentence may be exercised at any time after confirmation, and where, after review, a sentence remains effective it shall be reconsidered at intervals of six months; but no delay in complying with this section at any such intervals shall invalidate the sentence.

#### *Review of Summary Findings and Awards*

115.—(1) Where a charge has been dealt with summarily and the charge is not dismissed, the board or any officer superior in command to the officer who dealt summarily with the charge, shall be the authority to review the finding or award at any time.

Review of summary findings and awards.

(2) Where by reason of any mistake of law in the proceedings on the summary dealing with the charge or of anything occurring in those proceedings the reviewing authority is satisfied there had been a substantial injustice to the accused, that authority may quash the finding and any award on the finding.

(3) Where on a review under this section it appears to the said authority that a punishment awarded was invalid, or too severe, or (where the award included two or more punishments) that those punishments or some of them could not validly have been awarded in combination or are, taken together, too severe, the authority may vary the award by substituting such punishment or punishments as the authority may think proper, being a punishment or punishments which could have been included in the original award and not being in the opinion of the authority more severe than the punishment or punishments included in the original award.

#### *Findings of Insanity etc.*

116.—(1) Where, on the trial of a person by court martial, it appears to the court that the accused is by reason of insanity unfit to stand his trial, the court shall so find; and if the finding is confirmed in accordance with the following provisions of this section the accused shall be kept in custody in such manner as may be provided by or under rules made under this Part of this Act until the directions of the President are known or until an earlier time at which the accused is fit to stand trial.

Provisions where accused found insane.

(2) Where, on the trial of a person by court martial, it appears to the court that the evidence is such as, apart from any question of insanity, to support a finding that the accused was guilty of any offence, but that at the time of the act or omission constituting that offence the accused was by reason of mental disease or natural mental infirmity not criminally

responsible for the act or omission alleged as constituting the offence, the court shall find that the accused committed the act or omission but was insane at the said time, and thereupon the accused shall be kept in custody in such manner as may be provided by or under rules made under this Part of this Act until the directions of the President are known.

(3) In the case of any such finding as aforesaid the President may give orders for the safe custody of the accused during his pleasure in such place and in such manner as the President thinks fit.

(4) A finding under subsection (1) of this section shall not have effect unless and until the finding has been confirmed by the authority having power to confirm a finding of guilty by the court martial in question and the finding has been promulgated.

(5) Where the court or the confirming authority comes to or substitutes a finding under subsection (2) of this section, the confirming authority or, as the case may be, the reviewing authority shall not have power to substitute for that finding a finding of guilty; but save as aforesaid the provisions of this Act as to revision, confirmation and review (and in particular the provisions of this Act which confer power to substitute for any finding any other finding which would have been come to by the court martial in question) shall apply in relation to such findings as are provided for by subsection (2) of this section as those provisions apply in relation to findings of guilty.

(6) Unless otherwise provided in this Act or the context requires a different construction, references in this Act to a conviction or a finding of guilty in respect of any offence include references to findings under subsection (2) of this section in respect of the offence.

#### *Commencement, Suspension and Duration of Sentences*

Commencement of sentences.

117. Save as otherwise provided in this Act, a sentence of imprisonment shall begin to run from the beginning of the day on which the sentence was originally pronounced by the court martial trying the offender or, as the case may be, was originally awarded by the officer who tried the case summarily.

Duration of sentences of imprisonment.

118.—(1) Where any person serving a sentence of imprisonment under this Act becomes unlawfully at large during the currency of the sentence, then, in calculating the period for which he is liable to be imprisoned in pursuance of the sentence, no account shall be taken of the time elapsing during the period beginning with the day on which he became at large and ending with the day on which, as a person having become unlawfully at large, he is taken into military, naval or air force custody or the custody of a civil authority or (not having been taken into such custody) returns to the place in which he was imprisoned before he became unlawfully at large:

Provided that if he satisfies such authority as may be specified in that behalf by or under Imprisonment Rules that during any time during the last-mentioned period he was—

(a) in the custody of a civil authority; or

(b) if and in so far as Imprisonment Rules so provide, in the custody of any military, naval or air force authority of any country or territory outside Nigeria as respects which arrangements have been made under section one hundred and twenty of this Act otherwise than on

account of an offence committed by him while unlawfully at large, the last mentioned time shall not be disregarded in calculating the period for which he is liable to be imprisoned or detained in pursuance of the sentence imposed under this Act.

(2) In subsection (1) of this section the expression "civil authority" means a civil authority (whether of the Federation or of any country or territory outside Nigeria) authorised by law to detain persons, and includes a police officer.

(3) Without prejudice to the provisions of subsection (1) of this section, where any person serving a sentence of imprisonment has in accordance with Imprisonment Rules been temporarily released on compassionate grounds, then, in calculating the period for which he is liable to be imprisoned in pursuance of the sentence, no account shall be taken of the time elapsing during the period beginning with the day after that on which he is released and ending with the day on which he is required to return to custody.

(4) A person who for any period is released as mentioned in subsection (3) of this section or is otherwise allowed, in pursuance of Imprisonment Rules, out of naval custody for any period or subject to any conditions shall, on failure to return at the expiration of the period or to comply with the conditions be treated for the purposes of subsection (1) of this section as being unlawfully at large.

(5) A person serving a sentence of imprisonment in civil custody who, after being temporarily released under the civil law of the country or territory in which he is serving his sentence, is at large at any time during the period for which he is liable to be detained in civil custody in pursuance of his sentence, shall be deemed to be unlawfully at large if the period for which he was temporarily released has expired or if an order recalling him has been made in pursuance of the civil law of such country or territory.

119. A person sentenced to death or imprisonment and committed or transferred to a civil prison in pursuance of rules made under this Part of this Act or of Imprisonment Rules, shall while in that prison be confined and otherwise dealt with in the same manner as a person confined therein under a sentence of a civil court.

Special provisions as to civil prisons.

120. The President may from time to time make arrangements with the authorities of any country or territory outside Nigeria whereby sentences of death passed by courts martial may in accordance with rules made under this Part of this Act be carried out in establishments under the control of those authorities and sentences of imprisonment or detention under this Act may, in accordance with Imprisonment Rules, be served wholly or partly in such establishments.

Serving of sentences outside Nigeria.

121.—(1) A person who is serving a sentence of imprisonment in Nigeria may, in so far as may be specified by or under Imprisonment Rules, be removed out of Nigeria to any place where the unit or any part thereof to which for the time being he belongs is serving or is under orders to serve, but not to any other place.

Country in which sentence of imprisonment is to be served.

(2) Subject to the following provisions of this section, a person sentenced under this Act by a court martial held out of Nigeria to imprisonment for more than twelve months shall as soon as practicable after the confirmation of the sentence is completed be removed to Nigeria.

(3) Where a person has been sentenced under this Act by a court martial held out of Nigeria to imprisonment for more than twelve months, the confirming authority or reviewing authority may, notwithstanding anything in subsection (2) of this section, direct that he shall not be required to be removed to Nigeria until he has served such part of his sentence, not exceeding two years, as may be specified in the direction; and in determining whether or not to exercise the powers conferred by this subsection, a confirming authority or reviewing authority shall have regard to any recommendation in that behalf made by the court martial.

(4) Any direction of a confirming authority under this section may at any time be revoked by the confirming authority or by a reviewing authority, or may be superseded by any direction of the confirming authority or a reviewing authority which either authority might have given under subsection (3) of this section; and any direction of a reviewing authority under this section may at any time be revoked by a reviewing authority or be superseded as aforesaid.

(5) Any direction given under this section, and the revocation of any such direction, shall be promulgated.

(6) In ascertaining at any time for the purposes of this section the nature or length of a sentence regard shall be had to any commutation or remission of the sentence previously directed.

Duties of persons in charge of prisons and others to receive prisoners.

122.—(1) It shall be the duty, in so far as rules made under this Part of this Act or Imprisonment Rules so provide, of the superintendent or other person in charge of a civil prison (not being a naval prison) to receive any person duly sent to that prison in pursuance of any such rules and to confine him until execution of the sentence is completed or the prisoner is discharged or delivered over in due course of law.

(2) Where a person is in naval custody in pursuance of a sentence of imprisonment, then on receipt of a written order in that behalf purporting to be signed by that person's commanding officer or the officer in command of any Nigerian naval ship or naval establishment it shall be the duty of any such superintendent or other person as aforesaid or the police officer in charge of a police station or of any person in charge of any other place in which prisoners may be lawfully confined to keep that person in custody for a period not exceeding seven days unless the said person is earlier discharged or delivered over in due course of law.

*Trial and Time Limit of Persons ceasing to be subject to Naval Law*

Trial, etc., of offences although offender no longer subject to naval law.

123.—(1) Subject to the provisions of section one hundred and twenty-four of this Act, where an offence under this Act triable by court martial has been committed, or is reasonably suspected of having been committed, by any person while subject to this Act, then in relation to that offence he shall be treated, for the purposes of the provisions of this Act relating to arrest, keeping in custody, investigation of charge, trial and punishment by court martial (including confirmation, review and reconsideration) and execution of sentences as continuing subject to this Act notwithstanding his ceasing at any time to be subject thereto.

(2) Where a person in custody by virtue of this section whether before, during or after trial commits, or is reasonably suspected of having committed, an offence which if he were subject to naval law under this Act would be an offence under this Act triable by court martial, then in relation to that offence or suspected offence he shall be treated, for the purposes of the provisions of this Act mentioned in subsection (1) of this section and the provisions thereof as to the summary dealing with charges, as having been subject to this Act when the offence was committed or is suspected of having been committed and as continuing subject thereto thereafter.

(3) Where by virtue of either subsection (1) or subsection (2) of this section a person is treated as being at any time subject to this Act for the purpose of any provision of this Act, that provision shall apply to him—

(a) if he holds any naval rank, as to a person having that rank ;

(b) otherwise as to a person having rank which he had when last actually subject to this Act :

Provided that as respects any time after he has been sentenced for the offence in question and the sentence has been confirmed the said provision shall apply to him (in any case) as to a rating.

(4) Where apart from this subsection any provision of this Act would under subsection (3) of this section apply to a person in relation to different offences, as to a person having two or more different ranks in the navy, it shall apply to him as to a person having the lower or lowest of those ranks, as the case may be.

124.—(1) No person shall be tried by court martial for any offence (other than mutiny, failure to suppress mutiny, or the offence of desertion) unless the trial is begun within three years after the commission of the offence, regard not being had to any period of time during which that person was a prisoner of war or was illegally absent :

Limitation  
time for  
trial of  
offences  
under this  
Act.

Provided that—

(a) in the case of an offence against section eighty-two of this Act where proceedings for the corresponding civil offences are, by virtue of any written law, to be brought within the limited time, that limit of time shall apply to the trial of the offence under the said section eighty-two in substitution for the foregoing provisions of this subsection ;

(b) a person may, subject to any time limit prescribed by any written law mentioned in paragraph (a) and to the consent of the Attorney-General of the Federation, be tried by court martial for a civil offence committed outside Nigeria notwithstanding that it was committed more than three years before the beginning of the trial.

(2) A person shall not be triable by virtue of subsection (1) of section one hundred and twenty-three of this Act unless his trial is begun within three months after he ceases to be subject to this Act or the trial is for a civil offence committed outside Nigeria and the Attorney-General of the Federation consents to the trial ; but this subsection shall not apply to the offences of mutiny, failure to suppress mutiny and desertion under this Act.

*Relations between Naval and Civil Courts and Finality of Trials*Powers of  
civil courts.

125.—(1) Subject to the provisions of section one hundred and forty-seven, nothing in this Act shall restrict the offences for which a person may be tried by any civil court, or the jurisdiction of any civil court to try a person subject to this Act, for any offence.

(2) Where a person is tried by a civil court for any offence, and he has in pursuance of this Act been punished for any act or omission constituting (whether wholly or in part) that offence on summary trial under section eighty-eight or eighty-nine of this Act the civil court shall, in awarding punishment, have regard to his punishment in pursuance of this Act.

Offences  
already dis-  
posed of not  
to be retried.

126.—(1) Where a person subject to this Act—

(a) has been tried for an offence by a competent civil court or a court martial under service law ; or

(b) has been charged with an offence under service law, and has had the charge dismissed, or has been found guilty on the charge on summary trial under section eighty-eight or eighty-nine of this Act ; or

(c) has had an offence condoned by his commanding officer, he shall not be liable in respect of that offence to be tried by court martial or to have the case dealt with summarily under section eighty-eight or eighty-nine of this Act.

(2) For the purposes of this section—

(a) a person shall not be deemed to have been tried by a court martial if confirmation is withheld of a finding by the court martial that he is guilty of the offence ;

(b) a case shall be deemed to have been dealt with summarily notwithstanding that the finding of the officer who summarily tried the charge has been quashed or varied on review thereof ;

(c) an offence shall be deemed to have been condoned by the commanding officer of a person alleged to have committed the offence if, and only if, that officer or any officer authorized by him to act in relation to the alleged offence has with knowledge of all relevant circumstances informed him that he will not be charged therewith ;

(d) a person ordered under subsection (2) of section seventy of this Act, or the corresponding provision of any service law, to be imprisoned for an offence against that section or provision shall be deemed to have been tried by court martial for the offence.

(3) Where confirmation of a finding of guilty of an offence is withheld the accused shall not be tried again by court martial for that offence unless the order convening the later court martial is issued not later than twenty-eight days after the promulgation of the decision to withhold confirmation.

(4) Save as provided in the foregoing provisions of this section proceedings for an offence against this Act (whether summarily or before a court martial) shall not be barred on the grounds of condonation.

*Inquiries*Boards of  
inquiry

127.—(1) Subject to and in accordance with the provisions of rules made under this Part of this Act (in this Act referred to as "Boards of Inquiry Rules"), the board or any naval, military or air force officer

commanding a body of naval personnel may convene a board of inquiry to investigate and report on the facts relating to any matter which may be referred to such board of inquiry by the board or any such officer as aforesaid; and a board of inquiry shall, if directed so to do, express their opinion on any question arising out of any matter referred to them.

(2) A board of inquiry shall consist of such number of persons as may be provided for by the Boards of Inquiry Rules, who shall be persons subject to service law, and the president of a board of inquiry shall be an officer not below the rank of sub-lieutenant or corresponding rank.

(3) Evidence given before a board of inquiry shall not be admissible against any person in proceedings before a court martial or at a summary trial other than proceedings for an offence against section seventy-one or for an offence against section eighty-two when the corresponding offence is perjury.

128.—(1) Where a board of inquiry inquiring into the absence of an officer or rating reports that he has been absent without leave or other sufficient cause for a period specified in the report, not being less than twenty-one clear days, a record of the report shall in accordance with the Board of Inquiry Rules be entered in the service books.

Inquiries  
into absence.

(2) A record entered in pursuance of subsection (1) of this section shall, unless the absentee subsequently surrenders or is arrested, or the report of the board of inquiry is annulled by the board or a subsequent board of inquiry, have the like effect as a conviction by a court martial for desertion.

#### *Miscellaneous Provisions*

129.—(1) The following provisions of this section shall have effect where a person has been convicted by court martial of unlawfully obtaining any property, whether by stealing it, receiving it or retaining it knowing or having reason to believe it to have been stolen, fraudulently misapplying it or otherwise.

Restitution  
or compensa-  
tion for theft,  
etc.

(2) If any of the property unlawfully obtained has been found in the possession of the offender, it may be ordered to be delivered or paid to the person appearing to be the owner thereof.

(3) If there has been found in the possession of the offender any property (other than money) appearing to have been obtained by him by the conversion or exchange of any of the property unlawfully obtained, the property may be ordered to be delivered to the person appearing to be the owner of the property unlawfully obtained.

(4) Where money is found in the possession of the offender, then whether or not it appears to have been obtained as aforesaid an order may be made that there shall be paid out of that money to the person appearing to be the owner of the property unlawfully obtained such sum as may be specified in the order as or towards compensation for the loss caused to the said person by the offence, in so far as not otherwise made good under this Act or by the recovery of the property unlawfully obtained.

(5) Where any of the property unlawfully obtained has been sold or given in pawn to some other person who did not then know it to have been unlawfully obtained, an order may be made that, subject to the restitution to the owner thereof of the property sold or given as aforesaid,

there shall be paid to the said other person, out of any money found in the possession of the offender (whether or not the money appears to be proceeds of the sale or giving in pawn), such sum as may be specified in the order as or towards compensation for the loss caused to him in consequence of the sale or giving in pawn.

(6) Where any of the property unlawfully obtained has been given in exchange to some other person who did not then know it to have been unlawfully obtained, an order may be made that, subject to the restitution to the owner thereof of the property given as aforesaid, there shall be restored to the said other person the property taken in exchange for the property unlawfully obtained.

(7) An order under this section may be made by the court martial by whom the offender is convicted, or by the confirming authority, or any reviewing authority; but an order under this section made by a court martial shall not have effect until confirmed by the confirming authority and the provisions of this Part of this Act as to the confirmation and review of the proceedings of courts martial shall apply to an order under this section as they apply to a sentence.

(8) The operation of any order under this section shall be suspended—

(a) in any case, until the expiration of the period prescribed under Part V as the period within which an application for leave to appeal to the Supreme Court against the conviction must be lodged; and

(b) if such an application is duly lodged, until either the application is finally refused or is withdrawn or the appeal is determined or abandoned;

and where the operation of such an order as aforesaid is suspended under this section—

(i) it shall not take effect if the conviction is quashed on appeal;

(ii) the Supreme Court may by order annul or vary the order although the conviction is not quashed;

(iii) such steps shall be taken for the safe custody, during the period during which the operation of the order is suspended, of the property ordered to be restored or handed over or the money to which the order relates as may be provided by rules of court made under Part V of this Act.

(9) Notwithstanding anything in subsection (8) of this section, an order under this section shall not, so far as it relates to the delivery of property to the person appearing to be the owner thereof, be suspended if the court or authority making the order directs to the contrary in any case in which, in the opinion of the court or authority, the title to the property is not in dispute.

(10) An order under this section shall not bar the right of any person, other than the offender or a person claiming through him to recover any property delivered or paid in pursuance of such an order from the person to whom it is delivered or paid.

(11) In this section, "appearing" in relation to an order, means appearing to the court martial, or to the confirming authority, or reviewing authority making the order, as the case may require.

**130.** Any finding, sentence, determination or other thing required by this Act to be promulgated shall be promulgated either by being communicated to the accused or as the confirming or reviewing authority, as the case may be, may direct.

Promulgation of findings etc.

**131.—(1)** The record of the proceedings of a court martial shall be kept in the custody of the commander for not less than the prescribed period, being a period sufficient to ensure that the rights conferred by subsections (2) and (3) of this section shall be capable of being exercised.

Custody of proceedings of court martial and right to copies.

(2) Subject to the provisions of this section, any person tried by a court martial shall be entitled to obtain from the commander on demand at any time within the relevant period and on payment therefore at such rate as may be prescribed a copy of the record of the proceeding of the court.

(3) Where a person tried by court martial dies within the relevant period, his personal representatives or any person who in the opinion of the commander ought to be treated for the purposes of this subsection as his personal representative shall, subject to the provisions of this section, be entitled to obtain from the commander on demand at any time within the period of twelve months from the death and payment therefor at the prescribed rate a copy of the record of the proceedings of the court.

(4) If, on an application in pursuance of either subsection (2) or subsection (3) of this section for a copy of the record of any proceedings, the Minister certifies that it is requisite for reasons of security that the proceedings or any part thereof should not be disclosed, the applicant shall not be entitled to a copy of the proceedings or part to which the certificate relates.

(5) In this section the expression "the relevant period" in relation to any person tried by court martial, means the period of five years beginning with the date of his acquittal, or, where he was convicted, of the promulgation of the findings and sentence or, where a finding of guilty was not confirmed, of the promulgation of the withholding of confirmation :

Provided that where the proceedings relate to two or more charges and the person tried was acquitted on one or more of the charges and convicted on another or others, the relevant period shall be the period of five years beginning with the date of the promulgation of the findings of guilty and the sentence thereon or of the withholding of confirmation of that finding, or those findings.

(6) Any reference in this section to the record of the proceedings of a court martial includes a reference to the record of the proceedings with respect to the confirmation or revision of the findings and sentence of the court martial.

**132.** No action shall lie in respect of anything done by any person in pursuance of a sentence of imprisonment under this Act if the doing thereof would have been lawful but for a defect in any warrant or other instrument made for the purposes of that sentence.

Indemnity for prison officers, etc.

#### *Redress of Complaints*

**133.—(1)** If any officer or rating of the navy or the reserve thinks he has suffered any personal oppression, injustice or other ill-treatment from a superior officer or authority, he may make a complaint in accordance with such procedure as may be prescribed ; and if the complainant is

Complaints by officers and ratings.

not satisfied with the decision of any authority to whom his complaint is made or that authority neglects or refuses, when requested to do so, to forward the complaint to the next superior officer or authority, the complainant shall be entitled to make his complaint direct to the next superior officer or authority, and so on up to the navy board whose decision shall be final.

(2) It shall be the duty of any superior officer or authority to whom a complaint is made under this section to have the complaint investigated as soon as practicable and to take any steps for redressing the matter complained about which appear to that officer or authority to be necessary.

(3) No officer or rating shall be penalized for having made a complaint in accordance with this section.

Power to refer complaints by officer to the President.

134.—(1) In the case of a complaint by an officer the board may report the complaint through the Minister for the directions (if any) of the President.

(2) If a rating thinks himself wronged in any matter by his commanding officer, either by reason of redress not being given to his satisfaction on a complaint under subsection (1) of this section or for any other reason, he may make a complaint with respect thereto to any military, naval or air force officer under whom the complainant is for the time being serving, being an officer not below the rank of commodore or corresponding rank.

(3) It shall be the duty of a commanding officer or other officer to have any complaint received by him under this section investigated and to take any steps for redressing the matter complained of which appear to him to be necessary.

#### *Rules of Procedure, etc.*

Rules of procedure and other rules.

135.—(1) The President may make rules of procedure generally for the purposes of this Part of this Act, and without prejudice to the generality of the foregoing, rules may be made—

(a) for the convening, constitution and conduct of courts martial ;

(b) with respect to the execution of sentences of death under this Act, including the manner and place where such executions are to be carried out and the custody, treatment and removal of persons under sentence of death ;

(c) for the execution of sentences of imprisonment including the prisons, civil or otherwise, in which they are to be served, the classification, treatment, employment, discipline, control, removal and temporary release on compassionate grounds of persons serving such sentences and the appointment, powers and duties of inspectors, visitors, governors and other members of the staff and officers in charge of persons serving sentences of imprisonment ;

(d) with respect to field punishment ;

(e) for the convening, constitution and procedure of boards of inquiry, the rules of evidence to be observed and the taking of evidence by such boards, including the administration of oaths and affirmations to witnesses and the making of reports by such boards ;

(f) in respect of matters for which rules may be made under the foregoing provisions of this Part of this Act ;

(g) for such incidental and supplementary matters as appear requisite for the purpose of the foregoing.

(2) Notwithstanding the repeal of any Act by section two hundred and thirteen of this Act, all regulations, rules or instructions relating to discipline and trial of offences in operation immediately before the repeal of the Royal Nigerian Navy Act, 1960 shall continue in force and may be used with such adaptations, modifications and exceptions as are necessary to give effect thereto under this Act.

1960 No. 9

#### *Interpretation of this Part*

136.—(1) In this Part—

“air-force prison” means separate premises designated by the commander of the Nigeria Air Force for persons serving air force sentences of imprisonment ;

“civil prison” means a prison in Nigeria in which a person sentenced by a civil court to imprisonment can for the time being be confined ;

“convening officer”, in relation to a court martial, means the officer convening that court martial and includes his successor or any person for the time being exercising his or his successor’s functions ;

“military prison” means separate premises designated by the commander of the Nigerian Army for persons serving military sentences of imprisonment ;

“naval prison” means premises or vessels or parts of premises or vessels designated by the commander for persons serving naval sentences of imprisonment ;

“prescribed” means prescribed by Rules of Procedure ;

“prison” includes a civil prison and any military, naval or air force prison.

Interpretation of Part IV.

(2) Reference in this Part of this Act to a sentence of imprisonment are references to a sentence of imprisonment passed by a court martial or awarded summarily under section eighty-eight or section eighty-nine of this Act.

(3) References in this Part of this Act to detention or to sentences of detention shall include references to detention passed by a court martial or to any such sentence by the offender’s commanding officer.

(4) Where persons subject to this Act are appointed or drafted to a naval ship or establishment for duty those persons shall be treated for the purposes of this Act as belonging to the ship or establishment to which they are appointed or drafted.

(5) References in this Part of this Act to chief petty officers do not include references to acting chief petty officers.

(6) References in this Part of this Act to petty officers include references to acting petty officers and to acting chief petty officers.

#### PART V—APPEALS FROM COURTS MARTIAL

137. Subject to the following provisions of this Part of this Act, an appeal shall lie from decisions of a court martial to the Supreme Court with the leave of the Supreme Court ; and shall lie as of right without such leave, from any decision of a court martial involving a sentence of death.

Right of appeal.

Procedure for applying for leave to appeal or lodging appeal.

138.—(1) Leave to appeal against the finding of a court martial may be granted by the Supreme Court on application made to it by the appellant in the prescribed form setting out the grounds on which leave to appeal is sought and such other particulars (if any) as may be prescribed, and lodged with the registrar of that court or if rules of court otherwise allow, lodged with any other person.

(2) The application shall, in the case of any finding involving a sentence of death, be lodged within ten days of the date of promulgation of the finding, and in any other case within forty days thereof.

(3) The Supreme Court may extend the period within which application for leave to appeal is made in respect of any finding other than one involving a sentence of death, and whether or not the said period of forty days has expired.

(4) Rules of court may provide that, in such circumstances as may be specified therein, any application for leave to appeal or the appeal itself may, when lodged with such person other than the registrar as may be specified in such rules, be treated for the purposes of this section as having been duly lodged with the registrar.

(5) In considering whether or not to grant leave to appeal, the Supreme Court shall have regard to any opinion expressed by the judge advocate, if any, who acted at the court martial on the merits of the case as one for appeal.

(6) Where the Supreme Court dismisses an application for leave to appeal it may, if it considers the application to have been frivolous or vexatious, order that any sentence passed upon the applicant in the proceedings from which it was sought to bring the appeal shall begin to run from the day on which the Court dismisses the application.

Determination of appeals in ordinary cases.

139.—(1) Subject to the provisions of this and the next succeeding section, the Supreme Court shall allow an appeal against a conviction if it thinks that the finding of the court martial is unreasonable or cannot be supported having regard to the evidence or that it involves a wrong decision on a question of law, or that there was a miscarriage of justice; and in any other case the Supreme Court shall dismiss the appeal.

(2) Notwithstanding the provisions of the foregoing subsection, the Supreme Court may dismiss an appeal if of the opinion that the point raised in the appeal might be decided in favour of the appellant, but no substantial miscarriage of justice has occurred.

(3) If the Supreme Court allows an appeal against a conviction under this Part of this Act it shall quash the conviction.

(4) On an appeal under this Part of this Act against sentence the Supreme Court shall, if it is of opinion that a different sentence should have been passed, quash the sentence passed by the court martial and pass such other sentence (whether more or less severe) in substitution therefore as it thinks ought to have been passed, being a sentence which under section eighty-three or section eighty-four of this Act, could lawfully have been passed for the offence of which the appellant was convicted or, if it is not of opinion that a different sentence should have been passed, it shall dismiss the appeal.

(5) The term of any sentence imposed by the Supreme Court under subsection (4) of this section shall, unless that court otherwise directs, begin to run from the time from which it would have begun to run if it had been imposed in the proceedings from which the appeal was brought, and any such sentence shall be deemed for the purposes of this Act to be a sentence passed by the court martial and duly confirmed.

140.—(1) If it appears to the Supreme Court that an appellant, though not properly convicted on some charge preferred against him before the court martial by which he was tried, was properly convicted on some other charge so preferred, then, if the sentence passed by the court martial on the appellant was not one which could lawfully be passed by the court martial for the offence of which he was convicted on the other charge, the Supreme Court shall pass on the appellant, in substitution for the sentence passed on him by the court martial, such sentence as it thinks proper, being a sentence which, under section eighty-three or section eighty-four of this Act, could lawfully have been passed in respect of the charge on which the appellant was properly convicted, but not being a sentence of greater severity.

(2) Where an appellant has been convicted of an offence and the court martial by which he was tried could lawfully have found him guilty of some other offence, and it appears to the Supreme Court that the court martial must have been satisfied of facts which proved him guilty of that other offence, the Supreme Court may, instead of allowing or dismissing the appeal, substitute for the finding of the court martial a finding of guilty of the other offence and pass on the appellant, in substitution for the sentence passed on him by the court martial, such sentence as it thinks proper, being a sentence which, under section eighty-three or section eighty-four of this Act, could lawfully have been passed for that other offence but not being a sentence of greater severity.

(3) Where—

(a) an appellant has been convicted of an offence committed under circumstances involving the higher of two degrees of punishment, and it appears to the Supreme Court that the court martial by which he was tried ought to have found him guilty of the offence as being committed under circumstances involving the lower degree of punishment; or

(b) an appellant has been convicted of an offence and it appears to the Supreme Court that the court martial by which he was tried ought to have found him guilty of the offence subject to exception or variations, the Supreme Court may, instead of allowing or dismissing the appeal, substitute for the finding of the court martial a finding of guilty of the offence as being committed under circumstances involving the lower degree of punishment or, as the case may be, guilty of the offence subject to exceptions or variations and pass on the appellant, in substitution for the sentence passed on him by the court martial, such sentence as it thinks proper, being a sentence which, under section eighty-three or section eighty-four of this Act, could lawfully have been passed for the offence specified or involved in the substituted finding, but not being a sentence of greater severity.

(4) If, on appeal, it appears to the Supreme Court that, although the appellant committed the act or omission charged against him, he was insane at the time the act was done, or the omission made, so as not to be

Powers of  
the Supreme  
Court in  
special  
cases.

responsible according to law for his actions, the Supreme Court may quash the sentence passed at the trial and order the appellant to be kept in custody, under the provisions of section one hundred and sixteen of this Act, in like manner as on a special finding of insanity by the court martial by which the appellant was convicted.

(5) The term of any sentence imposed by the Supreme Court under any of the foregoing provisions of this section shall, unless the Supreme Court otherwise directs, begin to run from the time which it would have begun to run if it has been passed in the proceedings from which the appeal was brought, and any such sentence shall be deemed for the purposes of this Act to be a sentence imposed by the court martial and duly confirmed.

Appeals to be final

141. The determination by the Supreme Court of any appeal or other matter which it has power to determine under the provisions of this Part of this Act shall be final.

Supplementary powers of the Supreme Court.

142. For the purposes of this Part of this Act the Supreme Court may, if it thinks it necessary or expedient in the interests of justice, appoint any person with special expert knowledge to act as assessor in any case where it appears to the Supreme Court that such special knowledge is required for the proper determination by it of the case.

Proceedings to be heard in absence of appellants.

143. An appellant shall not be entitled to be present at the hearing of an appeal to the Supreme Court under this Part of this Act or at any proceedings preliminary or incidental to such an appeal except where rules of court provide that he shall have the right to be present or the Supreme Court gives him leave to be present, and accordingly any power of the Supreme Court under this Part of this Act to pass a sentence may be exercised notwithstanding the absence of the appellant.

Defence of appeals.

144. It shall be the duty of the board on an appeal against a decision of a court martial to undertake the defence of the appeal.

Right of appellant to present his case in writing.

145. An appellant may, if he so desires, instead of presenting his case orally, present it in writing in the prescribed form.

Suspension of death sentences.

146. Where a conviction by court martial involves sentence of death, the sentence shall not in any case be executed until the expiration of the period within which an appeal to the Supreme Court against the conviction may be lodged; and if such an appeal is lodged, the sentence shall not be executed pending the determination or dismissal of the appeal, or as the case may be, the appeal is abandoned.

Persons not to be tried again where conviction quashed.

147. Where the conviction of a person by a court martial for an offence has been quashed under this Part of this Act, he shall not be liable to be tried again for that offence by a court martial or by any other court.

Removal of prisoners for purposes of proceedings.

148. Imprisonment Rules may provide in what manner an appellant, when in custody, is to be taken to, kept in custody at, and brought back from any place at which he is entitled to be present for the purposes of this Part of this Act or any place to which the Supreme Court or a Justice thereof may order him to be taken for the purpose of any proceedings of the Supreme Court.

149. In the case of every appeal, or application for leave to appeal, under this Part of this Act to the Supreme Court against a decision of a court martial, it shall be the duty of the commander to furnish to the registrar of the Supreme Court, in accordance with rules of court, the proceedings of the court martial (including any proceedings with respect to the revision of the findings or sentence of the court martial in pursuance of subsection (1) of section one hundred and thirteen of this Act with respect to the confirmation of the finding and sentence of the court martial).

Furnishing, on appeal, of documents relating to trial.

150.—(1) The registrar of the Supreme Court shall furnish the necessary forms and instructions relating to appeals or applications for leave to appeal under this Part of this Act to any person requiring them, to persons in charge of places where persons sentenced by court martial may lawfully be confined for the purpose of serving their sentences, and to such other persons as the registrar thinks fit; and every person in charge of such a place as aforesaid shall cause the forms and instructions to be placed at the disposal of persons confined in that place who desire to lodge an appeal or make application for leave to appeal under this Part of this Act.

Duties of registrar of the Supreme Court in respect of appeals, etc.

(2) The registrar of the Supreme Court shall forthwith upon receipt of an appeal or application for leave to appeal under this Part of this Act, obtain and lay before the Supreme Court in proper form all documents, exhibits and other things relating to the proceedings in the court martial by which the appellant or applicant was tried, which appear necessary for the proper determination of the appeal or of the application, as the case may be.

151.—(1) The Chief Justice of Nigeria may make rules of court for regulating the procedure and practice to be followed in the Supreme Court for the purposes of this Part of this Act.

Rules of court.

(2) Rules of court made for the purposes of any provision of this Part of this Act may make different provision in relation to different classes of cases and may provide for any incidental or supplementary matters for which it appears to the Supreme Court to be necessary or expedient for the purposes of that provision to provide.

(3) Reference in this Part of this Act to "prescribed" shall be to any matter or thing prescribed by rules of court.

152. Nothing in this Part of this Act shall affect the exercise by reviewing authorities of the power conferred upon them by section one hundred and thirteen of this Act in respect of a decision of a court martial so far as regards the exercise by them of those powers at any time before the lodging with the registrar of the Supreme Court of an appeal or an application for leave to appeal, as the case may be, against the decision; and nothing in the Part of this Act shall affect the exercise by the President of the prerogative of mercy under the Constitution of the Federation.

Saving of reviewing authorities' powers.

153. Upon the hearing of any appeal from a court martial the Supreme Court shall consist of at least three Justices.

Composition of court.

Exercise of certain powers of the Supreme Court by a Justice.

154. Notwithstanding the provisions of section one hundred and fifty-three of this Act, any Justice of the Supreme Court may—

- (a) give leave to appeal, or
- (b) extend the time limit within which an application for leave to appeal otherwise than in the case of sentence of death may properly be lodged under section one hundred and thirty-eight of this Act ; or
- (c) allow an appellant to be present at any proceedings under this part of this Act,

but nothing in this section shall be construed to preclude the hearing and determination of any such application if a Justice refuses the application, and accordingly the appellant or applicant, as the case may be, shall be entitled, notwithstanding such refusal, to have the application dealt with before the Supreme Court sitting with not less than three Justices under the provisions of said section one hundred and fifty-three.

General provisions as to procedure. No. 12 of 1960.

155. Subject to the provisions of this Part of this Act and to any rules of court, the provisions of the Supreme Court Act, 1960, relating to the hearing of appeals from subordinate courts shall apply to the hearing and determination of an appeal under this Part of this Act.

#### PART VI.—PAY, FORFEITURES AND DEDUCTIONS

Regulations as to pay.

156. The President shall make regulations governing the pay, allowances and other emoluments of the officers and ratings of the navy (in this Act referred to as "pay regulations") and other matters pertaining thereto and in particular governing the following provisions of this Part of this Act.

Forfeitures and deductions : general provisions.

157.—(1) No forfeiture of the pay of an officer or rating shall be imposed unless authorised by service law or some other written law and no deduction from such pay shall be made unless so authorised or authorised by pay regulations.

(2) Pay regulations shall not authorise the making of any penal deduction, that is to say, a deduction to be made by reason of the commission of any offence or other wrongful act or in consequence of any negligence.

(3) The foregoing provisions of this section shall not prevent the making of pay regulations providing for the imposition of any forfeiture authorised by this Act or the making of any deduction so authorised, or for the time at which and manner in which sums may be deducted from pay to give effect to authorised deduction or the manner in which amounts may be so deducted in order to recover any fine imposed in pursuance of this Act, or as to the appropriation of any such sum or amount when deducted, or of providing for the determination of questions relating to forfeitures or deductions.

(4) Notwithstanding any deduction from the pay of an officer or rating, he shall (subject to any forfeiture) remain in receipt of pay at not less than such minimum rate as may be prescribed in pay regulations.

(5) Notwithstanding that forfeiture of pay of an officer or rating for any period has been ordered in pursuance of this Act, he shall remain in receipt of pay at such a minimum rate as aforesaid, but the amount received for that period may be recovered from him by deduction from pay.

(6) Any amount authorised to be deducted from the pay of an officer or rating may be deducted from any balance (whether or not representing pay) which may be due to him as an officer or rating and references in this Act to the making of deduction from pay shall be construed accordingly; and the whole or any part of any sum forfeited from an offender's pay may be recovered by deduction from any such balance.

158.—(1) The pay of an officer or rating may be forfeited—

Forfeiture  
pay for  
absence from  
duty.

(a) for any day of absence in such circumstances as to constitute an offence under section forty-nine or fifty of this Act, or, if the commander so directs, of other absence without leave;

(b) for any day of imprisonment, detention or cells awarded under service law by a court martial or upon summary trial, or of imprisonment or detention of any description to which he is liable in consequence of an order or sentence of a civil court;

(c) where he is found guilty (whether by court martial or upon summary trial) of an offence under service law, for any day (whether before or after he is found guilty) on which he is in hospital on account of sickness or injury certified by the proper medical officer to have been occasioned by the offence.

(2) The pay of an officer or rating may be forfeited for any day of absence by reason of his being made a prisoner of war if the commander is satisfied—

(a) that he was made a prisoner of war through disobedience of orders or wilful neglect of his duty; or

(b) that having been made a prisoner of war he failed to take any reasonable steps available to him to rejoin the service of Nigeria; or

(c) that having been made a prisoner of war he served with or aided the enemy in the prosecution of hostilities or measures calculated to influence morale or in any other manner whatsoever not authorised by international usage,

but, save as aforesaid, nothing in paragraph (a) of subsection (1) of this section shall apply to absence by reason of having been made a prisoner of war.

(3) Pay regulations may make provision as to the computation of time for the purposes of this section and in particular as to the counting or disregarding of parts of days.

159. Where an officer or rating charged with an offence before a civil court (whether within or without Nigeria) is sentenced or ordered by the court to pay any fine, penalty, damages, compensation or costs, and the whole or part thereof is met by a payment made by or on behalf of any naval authority, the amount of the payment may be deducted from his pay.

Deductions  
for payment  
of civil  
penalties.

160.—(1) Without prejudice to the provisions of this Act as to the imposition of stoppages as a punishment, the following provisions shall have effect where, after such investigation as may be prescribed by pay regulations it appears to the board, the commander or an officer authorised in pay regulations that any loss of, or damage to, public or service property has been occasioned by any wrongful act or negligence of an officer or rating (in this Act referred to as "the person responsible").

Compensation  
for loss  
occasioned  
by wrongful  
act or  
negligence.

(2) The board, the commander or authorised officer, as the case may be, may order the person responsible to pay as or towards compensation for the loss or damage, such sum as may be specified in the order, and such sum, in so far as not otherwise paid by the person responsible, may be deducted from his pay.

(3) No order shall be made under the provisions of subsection (2) of this section if, in proceedings before a court martial under service law, or upon summary trial, the person responsible—

(a) has been acquitted in circumstances involving a finding that he was not guilty of the wrongful act or negligence in question ; or

(b) has been awarded stoppages in respect of the same loss or damage, but save as aforesaid, the fact that such proceedings have been brought in respect of the wrongful act or negligence in question shall not prevent the making of an order or deductions under subsection (2) of this section.

Deductions  
for barrack  
damage.

161.—(1) Where damage occurs to any premises in which one or more units or parts of such units are quartered or billeted, or any fixtures, furniture or effects in or belonging to such premises are damaged or lost, and it appears on investigation in accordance with the provisions of pay regulations that the damage or loss was occasioned by the wrongful act or negligence of persons belonging to any of the units or parts of units in occupation of such premises, but that the said persons cannot be identified, any person belonging to any of such units or parts of units may be required to contribute towards compensation for the damage or loss such amount as may in accordance with pay regulations be determined to be just, and the amount may be deducted from his pay.

(2) The provisions of subsection (1) of this section shall extend to ships, trains, motor vehicles and aircraft in which units or parts of units are being transported and references to premises, quartering and occupation shall be construed accordingly.

Remission of  
forfeitures  
and deduc-  
tions.

162. Any forfeiture or deduction imposed under the provisions of sections one hundred and fifty-eight, one hundred and fifty-nine, one hundred and sixty or one hundred and sixty-one of this Act or under pay regulations may be remitted by the board or in such manner and by such authority as may be provided by such regulations.

## PART VII—GENERAL PROVISIONS

### *Exemptions for Members of Navy*

Exemption  
from tolls,  
etc.

163.—(1) Duties or tolls for embarking from or disembarking on any pier, wharf, quay or landing place in Nigeria, or for passing over any road, ferry or bridge in Nigeria, shall not be payable in respect of—

(a) a member of the navy on duty ;

(b) vehicles in naval service, being vehicles belonging to the Federation or any Region thereof or other vehicles driven by persons (whether a member of the navy or not) in the public service of the Federation of any Region thereof ;

(c) goods carried in such vehicles.

(2) Harbour dues or other charges for entering, leaving, and anchoring or mooring in, any harbour or port in Nigeria, shall not be payable in respect of any naval ship or vessel belonging to the Federation.

(3) In subsection (1) of this section the expression "in naval service" means employed under proper naval authority for the purposes of any ship, vessel or establishment of the navy.

164. No judgment, decree or order given or made against a member of the navy by any court in Nigeria shall be enforced by the levying of execution on any property of the person against whom it is given or made, being public property, used by him for naval purposes.

Exemption from taking in execution of property used for naval purposes.

165. The officers and ratings of the navy and the reserve shall, for purposes of the navy, be exempt from the provisions of any enactment relating to the storage, possession or transmission of firearms, explosives, gunpowder or munitions of war to the same extent and in the same manner as members of any other of the armed forces of Nigeria are so exempt.

Exemptions as to arms and explosives.

#### *Deserters and Absentees without Leave*

166.—(1) Any police officer may arrest without a warrant any person whom he has reasonable cause to suspect of being an officer or rating who has deserted or is absent without leave; and where no police officer is available, any other person may in like circumstances arrest without a warrant any such person.

Arrest of deserters and absentees without leave.

(2) If any person authorised to issue a warrant for the arrest of a person charged for a criminal offence is satisfied by evidence on oath that there is, or there is reasonably suspected of being, within the jurisdiction an officer or rating who has deserted or is absent without leave, or is reasonably suspected of having deserted or of being absent without leave, he may issue a warrant for the arrest of the officer or rating.

(3) Any person in custody in pursuance of this section shall as soon as practicable be brought before a magistrate's court.

(4) Notwithstanding the provisions of any other Act or rule of law, a person appearing before a magistrate's court under this section, shall not be admitted to bail.

167.—(1) Where a person who is brought before a magistrate's court is alleged to be an officer or rating of the navy who has deserted or is absent without leave, the following provisions shall have effect.

(2) If the person so before such court admits that he is illegally absent from the navy and the court is satisfied of the truth of the admission, then, unless he is in custody for some other cause, the court shall, or notwithstanding that he is in custody for some other cause, the court may, forthwith either cause him to be delivered into naval custody in such manner as the court may think fit or commit him to some prison, police station or other place provided for the confinement of persons in custody, to be kept there for such reasonable time as the court may specify (not exceeding such time as appears to the court reasonably

Proceedings before a civil court where persons suspected of illegal absence.

necessary for the purpose of enabling him to be delivered into naval custody) or until sooner delivered into such custody. Any time specified by the court may be extended by the court from time to time if it appears to the court reasonably necessary so to do for the purpose aforesaid.

(3) If such person does not admit that he is illegally absent as aforesaid, or the court is not satisfied of the truth of the admission, the court shall consider the evidence and any statement of the accused. If the court satisfied that he is subject to naval law under this Act and the court is also of opinion that there is sufficient evidence to justify trial of such person for an offence of desertion or absence without leave then, unless he is in custody for some other cause, the court shall cause him to be delivered into naval custody or commit him as aforesaid, but otherwise shall discharge him :

Provided that if any such person is in custody for some other reason the court may if it thinks fit, and in its discretion, act in accordance with this subsection.

(4) If proceedings are taken in a magistrate's court under this section, the law applicable in that court in relation to the constitution and procedure of magistrates' court holding preliminary inquiries and conferring powers of adjournment and remand on such court so acting, and as to evidence and the issue and enforcement of summonses or warrants to secure the attendance of witnesses, shall apply to such proceedings.

(5) Notwithstanding the provisions of any other Act or rule of law, a person appearing before a magistrate's court under this section, shall not be admitted to bail.

Deserters  
and  
absentees  
without  
leave sur-  
rendering to  
police.

168.—(1) Where a person elsewhere than at a police station surrenders himself to a police officer as being illegally absent from the navy, the police officer shall forthwith bring him to a police station. The police officer in charge of any such police station shall thereupon enquire into the case, and if it appears that such person is illegally absent from the navy, he may in his discretion, cause such a person to be delivered into naval custody without bringing him before a magistrate's court, or may bring him before such court.

(2) Notwithstanding the provisions of any other Act or rule of law, the person appearing before a magistrate's court under this section, shall not be admitted to bail.

Certificates  
of arrest or  
surrender.

169.—(1) Where a magistrate's court under this Part of this Act deals with a person as illegally absent, and that person is delivered into naval custody there shall at the time of such delivery be handed over a certificate in the prescribed form signed by a magistrate, containing particulars as to the arrest or surrender as the case may be, and of the proceedings before the court.

(2) Where after surrender a person is delivered into naval custody without being brought before a court, under the provisions of this or any other Act, there shall be handed over a certificate in the prescribed form signed by the police officer causing the delivery into naval custody, and such certificate shall contain particulars relating to the surrender.

(3) In any proceedings for an offence under section forty-nine or fifty of this Act—

(a) a document purporting to be a certificate under the relative subsection of this section, or under the corresponding provisions of any other Act relating to service law and to be signed as therein presented, shall be evidence of the matter stated in the document ;

(b) where the proceedings are against a person who has been taken into naval custody on arrest or surrender, a certificate in the prescribed form purporting to be signed by a provost officer or any corresponding officer of a force raised under the law of any other country, or by any other officer in charge of the guardroom or other place where that person was confined on being taken into custody, stating the fact, date, time and place of arrest or surrender shall be evidence of the matter stated in the certificate.

170.—(1) It shall be the duty of the superintendent or other person in charge of a civil prison to receive any person duly committed to that prison by a magistrate's court as illegally absent from the navy and to detain him until in accordance with the directions of the court he is delivered into naval custody.

(2) Subsection (1) of this section shall apply to the person having charge of any police station or other place (not being a prison) provided for the confinement of persons in custody as it applies to the superintendent of a prison.

Duties of superintendents of prisons and others to receive deserters and absentees.

*Offences relating to Naval Matters punishable by Civil Courts*

171. Any person who falsely represents himself to any naval, military, airforce or civil authority to be a deserter from the navy shall be guilty of an offence and liable on conviction to a fine not exceeding fifty pounds or to imprisonment for a term not exceeding three months or to both.

Punishment for pretending to be a deserter.

172. Any person who—

(a) procures or persuades any officer or rating of the navy to desert or to absent himself without leave ; or

(b) knowing that any such officer or rating is about to desert or absent himself without leave, assists him in so doing ; or

(c) knowing any person to be a deserter or absentee without leave from the navy, conceals him or assists in his rescue from custody, shall be guilty of an offence and liable on conviction to a fine not exceeding fifty pounds or to imprisonment for a term not exceeding one year, or to both.

Punishment for procuring and assisting desertion.

173. Any person who wilfully obstructs or otherwise interferes with any officer or rating of the navy acting in the execution of his duty shall be guilty of an offence and liable on conviction to a fine not exceeding fifty pounds or to imprisonment for a term not exceeding three months, or to both.

Punishment for obstructing members of the navy.

174. Any person who—

(a) produces in any officer or rating of the navy any sickness or disability ; or

Punishment for aiding malingering.

Intoxicating liquor not to be conveyed on board any naval ship.

178.—(1) Any person who shall, without the previous consent of the commanding officer, bring on board any naval ship any spirituous or fermented liquor of any description, or without such consent approach or hover about any such ship for the purpose of bringing on board, giving or selling spirituous or fermented liquor, shall be guilty of an offence against this section and shall be liable on conviction to a fine not exceeding ten pounds or imprisonment for a term not exceeding three months, or to both.

(2) Any officer or petty officer of the navy may, with or without ratings or persons under his command, search any vessels hovering about or approaching any ship of the navy, in circumstances giving rise to a reasonable suspicion that an offence under subsection (1) of this section is intended; and if on search any such liquor is found in or upon such vessel, the officer or petty officer may seize it, and such liquor shall be forfeited.

#### *Evidence*

Special provisions as to evidence.

179.—(1) The following provisions shall have effect with respect to evidence in proceedings under this Act, whether before a court martial, a civil court or otherwise.

(2) A document purporting to be a copy of the attestation paper signed by any person and to be certified to be a true copy by a person stated in the certificate to have the custody of the attestation paper shall be evidence of the enlistment of the person attested.

(3) The attestation paper purporting to be signed by a person on his enlistment shall be evidence of his having given the answers to questions which he is therein recorded as having given.

(4) A letter, return or other document stating that any person—

(a) was or was not serving at any specified time or during any specified period in the navy or the reserve or was discharged from the navy or the reserve at or before any specified time; or

(b) held or did not hold at any specified time any specified rank or appointment in the navy or the reserve, or had at or before any specified time been attached, posted or transferred to any naval ship or establishment, or at any specified time or during any specified period was or was not serving or held or did not hold any rank or appointment in any particular country or place; or

(c) was or was not at any specified time authorised to use or wear any decoration, badge, wound stripe or emblem, shall, if purporting to be issued by or on behalf of the commander, be evidence of the matter stated in the document.

(5) A record made in any service book or other document prescribed by regulations under this Act for the purposes of this subsection, being a record made in pursuance of service law or regulations, or otherwise in pursuance of naval duty, and purporting to be signed by the commanding officer or by any person whose duty it was to make the record, shall be evidence of the facts stated therein; and a copy of a record (including the signature thereto) in any such book or other document as aforesaid, purporting to be certified to be a true copy by a person stated in the certificate to have the custody of the book or original document, as the case may be, shall be evidence of the record.

(6) A document purporting to be issued by order of the board or the commander and to contain instructions or orders given or made by the board or the commander shall be evidence of the giving of the instructions or making of the orders and of their contents.

(7) A certificate purporting to be issued by or on behalf of the board or the commander and stating—

(a) that a decoration of a description specified in or annexed to the certificate is a naval decoration ; or

(b) that a badge, wound stripe or emblem of a description specified in or annexed to the certificate is one supplied or authorised by the President or the board,

shall be evidence of the matter stated in the certificate.

(8) A certificate purporting to be signed by a person's commanding officer or any officer authorised by him to give the certificate, and stating the contents of, or any part of, standing orders or other routine orders of a continuing nature made for any naval ship or naval establishment, shall in the proceedings against the said person be evidence of the matters stated in the certificate.

180.—(1) Where a person subject to this Act has been tried before a civil court (whether at the time of the trial he was so subject or not), a certificate signed by a judge or a magistrate and stating all or any of the following matters—

Proof of  
outcome of  
civil trial.

(a) that the said person has been tried before the court for an offence specified in the certificate ;

(b) the result of the trial ;

(c) what judgment or order was given or made by the court ;

(d) that other offences specified in the certificate were taken into consideration at the trial,

shall for the purposes of this Act be evidence of the matters stated in the certificate.

(2) A document purporting to be a certificate under this section and to be signed by a judge or a magistrate shall, unless the contrary is shown, be deemed to be such a certificate.

181.—(1) The original proceedings of a court martial under service law purporting to be signed by the president of the court and being in the lawful custody of the commander or of any person having the lawful custody thereof shall be admissible in evidence on production from that custody.

Evidence of  
proceedings  
of court  
martial.

(2) A document purporting to be a copy of the original proceedings of a court martial under service law or any part thereof and to be certified by the commander or any person authorised by him, or any other person having the lawful custody of the proceedings, to be a true copy shall be evidence of the contents of the proceedings or the part to which the document relates, as the case may be.

(3) This section applies to evidence given in any court, whether civil or criminal.

*Reductions in Rank*Restrictions  
on disrating.

182.—(1) A chief petty officer shall not be disrated except by sentence of a court martial under service law or by order of the Commander.

(2) A petty officer shall not be disrated except—

(a) by sentence of a court martial under service law ; or

(b) in the case of a petty officer or a leading rating, by award or order of the commander or of an officer by whom the commander's powers of disrating are exercisable by virtue of this Act ; or

(c) in the case of an able rate, by award or order of his commanding officer.

(3) Where it appears to the commander that a chief petty officer or a petty officer or a leading rating is unable to perform satisfactorily the functions of his rating, the commander may by order reduce the chief petty officer or petty officer to such rating as may be specified by the order or to ordinary rating ; and where it appears to a commanding officer that a leading rating serving under his command is unable to perform satisfactorily the functions of his rating, the commanding officer may by order reduce the leading rating to ordinary rating.

(4) The commander may by order direct that the powers conferred upon him by this Act to disrate any petty officer or a leading rating, may be exercised by officers not below the rank of captain under whose command the petty officers are serving ; and references in those subsections to the commander shall be construed accordingly.

(5) For the purposes of this section disrating does not include reversion from acting rate.

*Miscellaneous Provisions*Temporary  
reception  
into civil  
custody of  
persons  
under escort.

183.—(1) Where a person in naval custody when charged with, or with a view to his being charged with, an offence against Part IV or the corresponding provisions of any other service law, it shall be the duty of the superintendent or other person in charge of a civil prison, or of the person having charge of any police station or other place in which prisoners may be lawfully detained, upon delivery to him of a written order purporting to be signed by the commanding officer of the person in custody to receive him into his custody for a period not exceeding seven days.

(2) In this section "civil prison" has the meaning ascribed to it in section one hundred and thirty-six of this Act.

Avoidance of  
assignment  
of, or charge  
on, naval pay,  
etc.

184.—(1) Every assignment of or charge on, and every agreement to assign or charge, any pay, naval award, grant, pension or allowance payable to any person in respect of his or any other pensioner's service in the armed forces of Nigeria shall be void.

(2) Save as expressly provided by this Act, no order shall be made by any court the effect of which would be to restrain any person from receiving anything which by virtue of this section he is precluded from assigning and to direct payment thereof to another person.

(3) Nothing in this section shall prejudice any enactment providing for the payment of any sum to a bankrupt's trustee in bankruptcy for distribution among creditors.

185.—(1) An officer of a rank not below that of lieutenant-commander (in this Act referred to as an "authorised officer") may, outside Nigeria, take statutory declarations from persons subject to this Act.

Power of certain officers to take statutory declarations.

(2) A document purporting to have subscribed thereto the signature of an authorised officer in testimony of a statutory declaration being taken before him in pursuance of this section and containing in the jurat or attestation, a statement of the date on which and the place at which the declaration was taken and of the full name and rank of that officer shall be admitted in evidence without proof of the signature being the signature of that officer or of the facts so stated.

#### PART VIII—RESERVISTS AND PENSIONERS

186. Notwithstanding the provisions of section one hundred and ninety-four, this Part of this Act shall apply—

Reservists and pensioners.

(a) to every officer or rating who by virtue of this Act, is a member of the reserve ; and

(b) to every person who having served as an officer or rating in the navy is in receipt of a pension or annual allowance in respect of such service, and in this Act is referred to as a pensioner.

187.—(1) Every reservist shall be liable to be called out for training at such a place and for such periods not exceeding twenty-eight days in any one year as may be specified in regulations made under section one hundred and ninety-three of this Act.

Annual training.

(2) Every reservist may, during any training for which he may be called out, be attached to and trained in any ship, vessel or establishment.

188.—(1) The President may, at any time when occasion appears to require, call out reservists and pensioners or as many of them as he thinks necessary, to aid the civil power in the preservation of the public peace.

Calling out of reservists and pensioners to aid the civil power.

(2) Reservists and pensioners called out for service under this section shall not be liable to serve at any one time for a period exceeding twenty-eight days.

189.—(1) In the event of a state of war being declared or of insurrection, hostilities or public emergency it shall be lawful for the President, by proclamation, to call out any reservists and pensioners on permanent service. The President may, in any such proclamation give, or authorise the Minister to give, such directions as may seem necessary or proper for calling out such reservists and pensioners.

Calling out of reservists and pensioners on permanent service.

(2) A proclamation under this section and directions given in pursuance thereof shall be obeyed, and every reservist and pensioner called out by such directions shall attend at the place and time fixed by those directions, and at and after that time shall be deemed to be called out on permanent service.

(3) Every reservist or pensioner when called out on permanent service shall be liable to serve as an officer or rating of the navy until he is released or discharged.

Punishment  
for non-  
attendance.

190.—(1) Any reservist or pensioner who, without leave lawfully granted or other reasonable excuse, fails to appear at the time and place appointed for annual training, or when called out to aid the civil power or on permanent service, shall—

(a) if called out on permanent service, be guilty, according to the circumstances, of desertion within the meaning of section forty-nine of this Act or of absenting himself without leave within the meaning of section fifty of this Act ; or

(b) if called out to aid the civil power or for annual training, be guilty of absenting himself without leave within the meaning of section fifty of this Act.

(2) Any reservist or pensioner who commits any offence under this section shall be liable—

(a) to be tried by court martial, and, on conviction, to suffer imprisonment for a term not exceeding two years or such less punishment as is provided by this Act ; or

(b) to be tried by a magistrate's court and, on conviction, be liable to a fine not exceeding fifty pounds, or to imprisonment for a term not exceeding two years.

(3) Section eighty-five and sections one hundred and sixty-six to one hundred and seventy inclusive shall apply to reservists and pensioners who commit, or are alleged to have committed, or are reasonably suspected of having committed, an offence against this section as they apply to persons otherwise subject to naval law under this Act.

Record of  
illegal  
absence.

191. Where a reservist fails to appear at the time and place appointed for annual training or where a reservist or pensioner fails to appear when called out to aid the civil power or on permanent service, and his absence continues for not less than twenty-one clear days, an entry of such absence shall be made by an officer in the service books prescribed by regulations made under this Part of this Act and such entries shall be *prima facie* evidence of the fact of such absence.

Discharge  
during  
service.

192. A reservist or pensioner may be discharged by the commander at any time during the currency of any term of service as a reservist or pensioner, as the case may be, in accordance with regulations made under this Part of this Act.

Regulations  
as to reser-  
vists and  
pensioners.

193. The President may make regulations with respect to the government and discipline of the reservists and pensioners, and, without prejudice to the generality of the foregoing regulations may provide for—

(a) the calling out for training of reservists ;

(b) the calling out of reservists and pensioners to aid the civil power and on permanent service ;

(c) the pay of reservists when on the reserve and for the pay of reservists and pensioners when called out under this Part of this Act ;

(d) requiring reservists and pensioners to report themselves from time to time, and to obtain the permission of the commander, or such other officer so authorized by regulations, before leaving Nigeria ; and

(e) any matter which is required by this Part of this Act to be prescribed.

## PART IX.—APPLICATION OF THE ACT AND SUPPLEMENTARY PROVISIONS

*Application*

194.—(1) The following persons shall be subject to this Act—

- (a) officers and ratings of the navy ;
- (b) officers of the reserve and pensioners when called out on service ; and
- (c) reservists called out for training, to aid the civil power or on permanent service ;
- (d) pensioners called out to aid the civil power or on permanent service.

Application  
of the Act.

(2) This Act shall apply to the persons subject thereto under the provisions of this section and in relation to the units raised under this Act as well outside as within Nigeria.

195.—(1) The provisions of this or any other Act in so far as they contain or refer to the word "rating" or other word importing reference to persons of the male sex only as, or as having been, members of the navy and accordingly subject to service law under this Act, shall have effect as if for any such word there had been substituted therein words having a like meaning in other respects but importing a reference to persons of either sex.

Application  
of the Act to  
women.

(2) In relation to women members of the navy, this Act shall have effect subject to the following modifications—

- (a) so much of Parts I, II, III and VIII as relate to service in, and transfer to, the reserve shall not apply ;
- (b) the punishment of extra work or drill specified in the First Schedule shall not apply ;
- (c) references in sections two hundred and two hundred and two of this Act to a widow shall be construed as references to a widower.

First  
Schedule.

196.—(1) Subject to the modifications specified in subsection (2) of this section, where any unit is on active service, and a person is employed in the service of that unit or any part thereof or accompanies such unit or part thereof and is not otherwise subject to service law, Part IV of this Act shall apply to the person so employed or accompanying the unit as the said Part applies to members of the navy.

Application  
of the Act  
to civilians.

(2) The modifications referred to in subsection (1) of this section are as follows :—

(a) the punishments which may be awarded by a court martial shall include a fine, but shall not include any other punishment less than imprisonment ;

(b) the punishment which may be awarded where a charge is dealt with summarily shall, in the case of any offence, be a fine not exceeding ten pounds, but no other punishment ;

(c) the following provision shall have effect in substitution for subsections (2) to (4) inclusive of section eighty-five of this Act, that is to say that a person may be arrested by a provost officer, by any chief petty officer or petty officer legally exercising authority under a provost officer or on his behalf, or by order of any officer ;

(d) the provisions of this Act relating to the investigation of, and summary dealing with, offences shall, save as otherwise expressly provided, apply as they apply to ratings ;

(e) for the purposes of the provisions of this Act relating to the investigation of offences, the commanding officer shall be such officer as may be appointed by an officer authorised to convene a court martial ;

(f) for references in sections one hundred and twenty-three and one hundred and twenty-four to being, continuing, or ceasing to be subject to naval law under this Act there shall be substituted references to being, continuing to be or ceasing to be in such circumstances that Part IV applies, and subsection (3) of section one hundred and twenty-three shall not apply.

(3) Any fine awarded by virtue of this section, whether by a court martial or the commanding officer, shall be recoverable as a debt due to the Government of the Federation.

Application  
of the Act to  
passengers.

197. The provisions of Part IV of this Act shall, to such extent and subject to such modifications as may be prescribed by regulations made by the President, apply to persons embarked as passengers on board ships or aircraft of the navy (not being persons who are subject to this Act by virtue of any of the provisions of this Act or are subject to military or air force law), as they apply to persons subject to this Act.

#### *Wills and Distribution of Property*

Ratings on  
enlistment to  
register the  
name of  
person to  
whom estate  
is to be paid  
in event of  
his dying  
intestate.

198.—(1) Every rating on enlistment shall declare the name of the person or persons to whom, in event of his dying without having made a valid will, any money or personal property due or belonging to him should be paid or delivered ; or a rating may direct that his estate is to be administered by the customary court (by whatever name called) of some named place according to the customs of his tribe. The name of such person or customary court shall be recorded on his attestation paper, and the record shall be verified periodically. It shall be the duty of the rating to report any alteration in the record which he wished made.

(2) Any officer of the navy or of the Accountant-General or any public department, having in his or its charge or control any pay, accumulations of pay, gratuity or other allowance, or any personal property or money belonging to any rating dying intestate who has complied with the above conditions, may pay or deliver the same to the person whose name has been recorded, or to a customary court of the place named by the rating, in the manner prescribed.

Ratings'  
wills : special  
provisions.

199.—(1) Any will made by a rating shall be valid for disposing of any money or personal property which is due or belonging to him at his decease if it is in writing and signed or acknowledged by him in the presence of, and in his presence attested by one witness, being an officer of the navy or any government medical officer. The will shall be deemed well made for the purpose of being admitted to probate, and the person taking out representation to the testator under such will shall exclusively be deemed the testator's representative with respect to the money or personal property thereby bequeathed.

(2) Any officer of the navy or of the Accountant-General or any public department, having in his or its charge or control any pay accumulation of pay, gratuity or other allowance, or any personal property or money belonging to such testator, not exceeding in the

aggregate the value of one hundred pounds, may pay or deliver the same to any person entitled thereto under the will, or to the person entitled to procure probate of or administration under such will, although probate or administration may not have been taken out.

(3) If the value of the money and personal property exceeds one hundred pounds, the paymaster or other officer or public department, having charge or control thereof shall require probate or administration to be taken out and thereupon pay or deliver the said money and effects to the legal representative of the deceased.

200. If any rating dies without having complied with the requirements of this Part of this Act as to the disclosure of next of kin or has not made a will valid under this or any other enactment relating to wills and for the time being in force, any officer of the navy or the Accountant-General or any public department having in his or its charge or control money or personal property of the deceased may, with the concurrence of the commander or an officer acting on behalf of the commander, pay or deliver such money or personal property to any claimant who proves to the satisfaction of the commander or such officer, relationship as the widow of the deceased or the child or other near relative of the deceased, as the case may be, according to the rules of succession of the tribe to which the deceased belonged. If there are more of such claimants than one, payment or delivery may be made in such shares and proportions as the claimant would be entitled to receive under the rules of succession prevailing among such tribe, or as nearly as may be.

Distribution  
in case of  
deceased  
rating's  
intestacy.

(2) Where the rating was a moslem, the distribution of the estate may be carried out by the alkali's court of the district from which the deceased person came, and the alkali shall be responsible to the regional Administrator-General or the Federal Administrator-General as the case may require, for the carrying out of the distribution in accordance with Islamic law. If there is no such court in the district, the distribution may be made as nearly as may be in accordance with such law.

201.—(1) Where probate of the will or administration with or without the will annexed of the estate of a deceased rating is not taken out, and an officer of the navy, the Accountant-General or officer of any public department, before disposing of the money and personal property of the deceased has notice of any debt due by the deceased, he shall, anything to the contrary in this Part of this Act notwithstanding, apply such money and property as may remain in his authority or control, or so much thereof as may be requisite in or towards the payment of such debt, if he is satisfied—

Payment of  
debts of  
deceased  
rating.

(a) that the claimant has proved the debt to the satisfaction of the commander or of the officer acting on behalf of the commander; and

(b) that a demand for the payment of the debt was made within one year after such death; and

(c) that the debt was incurred within three years before the death of the rating.

(2) A person claiming to be a creditor of a deceased rating shall not be entitled to obtain payment of his debt out of any money in the hands of any officer of the navy or of the Accountant-General or any public department, except by means of a claim on any officer responsible for a rating's pay, and proceedings thereon under and in accordance with this

Act. If the estate is being administered by a customary court, any government debt shall be paid by the officer concerned before the balance of the estate is passed to the customary court, and that court shall thereafter be responsible to see that all other debts are settled before final distribution of the estate of the deceased rating under this section.

Property of deceased rating distributed subject to rights of creditors.

202. Where money or personal property of a deceased rating or any part thereof is paid or delivered to any person recorded as next of kin under this Part of this Act or as beneficiary under the will of the deceased or as his widow or child, or otherwise in accordance with this Act as a near relative, any creditor of the deceased shall have the same rights and remedies against the person to whom the money or personal property is paid or delivered as if such person had received the money or personal property as legal personal representative of the deceased.

Deceased rating's money undisposed of applied to prescribed fund.

203.—(1) Subject to the provisions of this section, if money or personal property belonging to a deceased rating, or any part thereof, remains for one year undisposed of or unappropriated, and without any valid claim thereto having been made, it shall after conversion into cash where necessary, be paid over to the Accountant-General and be applied towards forming a fund for the benefit of ratings and ex-ratings of the navy who are in distress, or for the benefit of the navy generally, or for charitable purposes.

(2) The application under the foregoing subsection of any such money or property or part thereof towards such fund shall not be a bar to any subsequent claim by any person, established within twelve months after such application.

(3) The Minister after consultation with the board, may make regulations for the formation of the fund and any disbursements may be made out of such fund in accordance with the regulations. The regulations may provide for the fund to be identical with the Nigerian Navy Benefit Fund under this Act or for the fund to be a separate fund administered for the purposes of this section.

Application of money, etc., in case of desertion.

204. Money or other property of a deserter under this Act in charge or control of an officer of the navy, the Accountant-General or any public department shall be disposed of as nearly as may be in accordance with the provisions of section two hundred and one of this Act or as may otherwise be prescribed under this Act, and if that section is invoked it shall have effect accordingly.

Uniforms, and decorations of deceased rating.

205. Notwithstanding any other provisions of this Act, uniforms, medals and decorations shall not comprise part of the personal estate of any deceased rating for the purpose of satisfying claims of creditors or for any of the purposes of administration under this Act or otherwise, and they shall be delivered to and held by the commander or officer authorised by him and be disposed of in such manner as may be prescribed.

#### Miscellaneous

Power to make regulations generally.

206. The President may in any case not otherwise provided for under this Act make regulations generally for prescribing or providing for an act, matter or thing.

207.—(1) Any power conferred by this Act to make regulations, rules, orders or other instruments shall include power to make provision for specified cases or classes of cases, and to make different provisions for different classes of cases, and for the purposes of any such instrument classes of cases may be defined by reference to any circumstances specified in the instrument.

Powers exercisable in subsidiary legislation.

(2) Any such regulations, rules, orders or other instruments as aforesaid may impose conditions, require acts or things to be performed or done to the satisfaction of any person named therein whether or not such persons are members of the navy, empower such persons to issue orders either orally or in writing requiring acts or things to be performed or done or prohibiting acts or things from being performed or done, and prescribe periods or dates upon, within or before which such acts or things shall be performed or done or such conditions shall be fulfilled and provide for appeal against any such order, requirement or direction.

208.—(1) In this Act the expression "on active service" in relation to any unit means that it is engaged in operations against an enemy, and in relation to a person means that he is serving in or with such a unit which is on active service.

Provisions as to active service.

(2) Where it appears to the President that, by reason of the imminence of active service or of the recent existence of active service, it is necessary for the service of the public that a unit should be deemed to be or continue to be on active service he may declare that for such period, not exceeding three months, beginning with the coming into force of the declaration as may be specified therein that unit shall be deemed to be on active service.

(3) Where it appears to the President that it is necessary for the service of the public that the period specified in a declaration under subsection (2) of this section should be prolonged or, if previously prolonged under this subsection should be further prolonged, he may declare that the said period shall be prolonged by such time, not exceeding three months, as may be specified in the declaration under this subsection.

(4) If at any time while any unit is deemed to be on active service by virtue of the foregoing provisions of this section, it appears to the President that there is no necessity for the unit to continue to be treated as being on active service, he may declare that as from the coming into operation of the declaration the unit shall cease to be, or to be deemed to be, on active service.

209. An order or determination by a naval officer or naval authority may, unless otherwise prescribed by rules or regulations made under this Act, be signified under the hand of any officer authorised in that behalf; and any instrument signifying such an order or determination and purporting to be signed by an officer stated therein to be so authorised shall unless the contrary is proved, be accepted by all courts and persons as sufficient evidence accordingly.

Execution of orders, instruments, etc.

210.—(1) All fines awarded under Part IV and section one hundred and ninety-six of this Act shall be paid over to the Accountant-General and be applied towards forming a fund to be known as the Nigerian Navy Benefit Fund for the purpose of making money available to the benefit of ratings and ex-ratings of the navy who are in distress, or for the benefit of the navy generally, or for charitable purposes.

Nigerian Navy Benefit Fund.

(2) The minister, after consultation with the board, may make regulations for the formation of the benefit fund, and any disbursements may be made out of such fund in accordance with the regulations.

Rights of  
officers.

211. Officers of the navy shall have and enjoy the like powers, rights, immunities and privileges as are by any means conferred upon and enjoyed by commissioned officers of any other of the armed forces of Nigeria.

Application  
of other Acts.

212.—(1) The President may, by order, apply, with all necessary modifications and adaptations, in relation to the board, the chairman of the board and the navy (as well officers and rating as property and institutions) any of the enactments relating to the Army Council, the Minister of Defence and to the Army (as well officers and other ranks as military property and institutions).

(2) Where any enactment is to be applied under the foregoing subsection, the expression "enactment" shall include any enactment conferring powers, rights, exemptions or abatements from taxation or immunities, or imposing duties or disabilities on such officers or airmen, or other ranks, as the case may be.

Repeal and  
transitional  
provisions.  
Fourth  
Schedule.  
Third  
Schedule.

213.—(1) The enactment act out in the Fourth Schedule to this Act are repealed to the extent specified in the second column of that Schedule.

(2) The transitional provisions set out in the Third Schedule to this Act shall have effect in connection with the repeal of the Royal Nigerian Navy Act, 1960.

Savings.

214. Notwithstanding the provisions of subsection (1) of section two hundred and thirteen of this Act all ratings who were raised under the Royal Nigerian Navy Act, 1960, and serving in the navy on the day on which this Act comes into operation shall be deemed to have been enlisted under this Act but such ratings shall not be required to serve in the navy for a longer period than that for which they were required to serve at the time of their original enlistment or re-engagement.

Interpreta-  
tion.

215.—(1) In this Act, unless the context otherwise requires—

"Accountant-General" means the Accountant-General of the Federation ;

"acting rank" means rank of any description in the navy and however called and being such that a commanding officer may, with or without preferring a charge under this Act, order the holder to revert to a lower rank or to his substantive rank as the case may be, and "acting chief petty officer" and "acting petty officer" shall be construed accordingly ;

"aircraft" means any machine for flying, whether propelled by mechanical means or not, and includes any machine of the type known as a hovercraft as well as any description of balloon ;

"the air council" means the air council established under section three of the Air Force Act, 1964 ;

"aircraft material" includes—

(a) parts of, and components of or accessories for, aircraft, whether for the time being in aircraft or not,

(b) engines, armaments, ammunition and bombs and other missiles of any description in, or for use in, aircraft,

(c) any other gear, apparatus or instruments in, or for use in, aircraft,

(d) any apparatus used in connection with the taking-off or landing of aircraft or for detecting the movement of aircraft, and

(e) any fuel used for the propulsion of aircraft and any material used as a lubricant for aircraft or aircraft material ;

"aircraft papers" includes books, documents, forms and writings of whatsoever description and whether or not relating to the flight of the aircraft when captured or to any other flight, which are delivered up or found aboard such aircraft ;

"the air force" means the Nigerian air force raised under the Air Force Act, 1964 ;

"air signal" means any message, signal or indication given, by any means whatsoever, for the guidance of aircraft or a particular aircraft ;

"allied forces" means military, naval or air forces of any country allied to, or associated with, the Federation and includes any Commonwealth force ;

"armed forces of Nigeria" means any of the military, naval and air forces raised by the Government of the Federal Republic of Nigeria ;

"the Army" means the Nigerian army raised under the Nigerian Army Act, 1960 ;

"the army council" means the Nigerian army council established under section six of the Nigerian Army Act, 1960 ;

"arrest" includes open arrest ;

"before the enemy", in relation to a person, means that he is in action against the enemy or about to go into action against the enemy or is under attack or threat of imminent attack by the enemy ;

"the board" means the Navy Board established under section three of this Act ;

"Boards of Inquiry Rules" means rules regulating boards of inquiry made under this Act ;

"civil court" means a court of competent criminal jurisdiction, but does not include any customary court by whatever name called ;

"civil offence" has the meaning assigned to it in subsection (2) of section eighty-two of this Act ;

"commanding officer", in relation to any person, means the officer commanding the unit to which the person belongs or is attached ;

"corresponding rank", in relation to any rank of any other of the armed forces of Nigeria or an allied force means such rank in that force as may be declared under this Act to correspond with a rank under this Act ;

"court martial", save where expressed to be under service law, means a court martial under this Act ;

"damage" and cognate expressions include destruction ;

"date of attestation", in relation to any person, means the date on which he is attested as having enlisted in the navy ;

"decoration" includes any medal, medal ribbon, clasp and good conduct badge ;

"desertion" shall be construed in accordance with subsection (3) of section forty-nine of this Act ;

"enemy" means all persons engaged in armed operations against Nigeria or allied forces, and includes armed mutineers, armed rebels, armed rioters and pirates ;

"executive officer" means the officer carrying out the executive duties of the ship or establishment ;

"imprisonment rules" means rules regulating imprisonment made by the President under this Act ;

"independent command" means a ship whose officers and men are appointed or drafted direct to her and borne on her books ;

"junior rating" means a rating enlisted in accordance with the provisions of subsection (2) of section sixteen ;

"the Minister" means the Minister charged with responsibility for matters relating to Defence ;

"the navy" means the Nigerian Navy ;

"naval service" means service under the provisions of this Act otherwise than service in the reserve ;

"officer" means in relation to the navy, a person of or above the rank of cadet, and, in relation to any other forces, means an officer of rank corresponding to the said rank or any superior rank ;

"petty officer" includes chief petty officers and petty officers and ratings of equivalent status in all branches, except when used as the title of seaman ratings ;

"provost officer" means a provost marshal or officer appointed to exercise the functions conferred by or under service law on provost officers ;

"public", when used adjectivally, means belonging to the Government of the Federation or of any Region thereof, or to the government of the country to which any allied force serving or operating in Nigeria belongs ;

"rating" means a member of the navy of or below the rank of chief petty officer, and references in this Act to a rating, or to a rating of any particular rank, include references to a soldier or airman of rank corresponding with that rate, as the case may be ;

"the reserve" means the body of naval personnel comprised of those persons who are subject to reserve service or liability under this Act ;

"service" when used adjectivally, means belonging to or connected with the armed forces of Nigeria ;

"service law" means this Act, the Nigerian Army Act, 1960, and the Air Force Act, 1964, and includes the military, naval or air force law of any allied force ;

"ship" includes any description of vessel ;

"ships papers" includes books, documents, forms and writings of whatsoever description and whether or not relating to the voyage of the ship when captured or to any other voyage, which are delivered up or found aboard such ship ;

"steals" has the meaning assigned to it in the Criminal Code ;

"stoppages" means in relation to pay, the recovery by deductions from the pay of the offender, of a specified sum by way of compensation for any expense, loss or damage occasioned by the offence ;

"tender" means a ship or vessel whose officers and men are appointed or drafted to and borne on the books of another ship or vessel being a parent ship or vessel ;

"unit" means an establishment, base or any other formation of naval personnel which has been declared to be a unit by the board.

(2) Where by this Act it is provided that any person subject to naval law under this Act shall be liable on conviction by court martial to imprisonment and no term or maximum term is specified, the person so convicted shall be liable to imprisonment for any term.

216.—(1) This Act may be cited as the Navy Act, 1964, and shall come into operation on a day to be appointed by the President by order in the Gazette.

(2) This Act shall apply throughout the Federation.

Short title,  
commence-  
ment and  
application.

## SCHEDULES

### FIRST SCHEDULE

Section 89

#### A. Officers who can try ratings summarily and their powers of summary punishment

(i) *Commanding officer of a ship or establishment if of the rank of lieutenant or above*

<i>Punishment</i>	<i>Qualification</i>
1. Imprisonment	Not exceeding three calendar months. Warrant required
2. Dismissal from the navy	Warrant required
3. Detention	Not exceeding three calendar months. Warrant required
4. Disrating	Warrant required
5. Reduction to 2nd class for conduct	Warrant required
6. Deprivation of loyal services medal	Warrant required
7. Deprivation of good conduct badges	Warrant required
8. Severe reprimand by the captain	Only to leading ratings and above
9. Extra work and drill	Not exceeding 14 days
10. Stoppage of leave	Not exceeding 30 days
11. Mulcts for improper absence	

FIRST SCHEDULE—*continued*

<i>Punishment</i>	<i>Qualification</i>
12. Mulcts of pay for drunkenness	
13. Extra work or drill	Not exceeding 7 days, and for not longer than two hours on any one day
14. Reprimand	
(ii) <i>Commanding officer of a ship or establishment if below the rank of lieutenant</i>	
<i>Punishment</i>	<i>Qualification</i>
9. Extra work and drill	Not exceeding 7 days
10. Stoppage of leave	Not exceeding 14 days
11. Mulcts for improper absence	
12. Mulcts of pay for drunkenness	
13. Extra work or drill	Not exceeding 7 days, and for not longer than two hours on any one day
14. Reprimand	
(iii) <i>Executive officer (if of the rank of commander) when delegated with powers of punishment by the commanding officer</i>	
<i>Punishment</i>	<i>Qualification</i>
9. Extra work and drill	Not exceeding 14 days
10. Stoppage of leave	Not exceeding 14 days
13. Extra work or drill	Not exceeding 7 days and for not longer than two hours in one day.
14. Reprimand	
(iv) <i>Executive officer (if of the rank of lieutenant or above) when delegated with powers of punishment by the commanding officer.</i>	
<i>Punishment</i>	<i>Qualification</i>
9. Extra work and drill	Not exceeding 7 days
10. Stoppage of leave	Not exceeding 7 days but not to chief petty officers or petty officers if executive officer is below the rank of commander
13. Extra work or drill	Not exceeding 7 days and for not longer than two hours in one day
14. Reprimand	
(v) <i>Officer of the watch or day (if of the rank of lieutenant or above) when delegated with power of punishment by commanding officer, or a departmental officer of the rank of lieutenant or above when delegated with power by commanding officer to punish any rating of his department for an offence in connection with the duties of that department but not connected with the general duties of the ship or naval establishment</i>	
13. Extra work or drill	For one day only and for not longer than two hours on that day

FIRST SCHEDULE—*continued*

## B. Warrant Punishment

*Punishments No. 1 to No. 7 above inclusive (which may be known as warrant punishments) shall not have effect unless a warrant is made out, approved as required by the Schedule and formally read to the accused in public*

## C. Approval of warrants is required as follows :—

<i>Punishment</i>	<i>Approving Authority</i>
1. Imprisonment .. .. .	The Commander
2. Dismissal .. .. .	The Commander
3. Detention .. .. .	The Commander
4. Disrating .. .. .	The commander if in Nigerian waters or if on detached service an officer of captain's rank or above in the case of a Petty Officer or a leading seaman
5. Reduction to 2nd class for conduct	The commander if in Nigerian waters or if on detached service an officer of the rank of commander or above
6. Deprivation of Loyal Service Medal	The commander
7. Deprivation of good conduct badges	The commander if in Nigerian waters ; if on detached service, an officer of the rank of commander or above may approve the deprivation of one good conduct badge.

## SECOND SCHEDULE

## Section 102

*Alternative Offences of which Accused may be convicted by Court Martial*

<i>Offence Charged</i>	<i>Alternative Offence</i>
1. Communicating with or giving intelligence to the enemy, either with intent to assist the enemy or without authority	1. Disclosing information without authority
2. Any offence against subsection (1) of section forty-two	2. Any offence against subsection (2) of section forty-two
3. Striking his superior officer	3. (a) Using violence to his superior officer otherwise than by striking him, or (b) Offering violence to his superior officer.

FIRST SCHEDULE—*continued*

<i>Punishment</i>	<i>Qualification</i>
12. Mulcts of pay for drunkenness	
13. Extra work or drill	Not exceeding 7 days, and for not longer than two hours on any one day
14. Reprimand	
(ii) <i>Commanding officer of a ship or establishment if below the rank of lieutenant</i>	
<i>Punishment</i>	<i>Qualification</i>
9. Extra work and drill	Not exceeding 7 days
10. Stoppage of leave	Not exceeding 14 days
11. Mulcts for improper absence	
12. Mulcts of pay for drunkenness	
13. Extra work or drill	Not exceeding 7 days, and for not longer than two hours on any one day
14. Reprimand	
(iii) <i>Executive officer (if of the rank of commander) when delegated with powers of punishment by the commanding officer</i>	
<i>Punishment</i>	<i>Qualification</i>
9. Extra work and drill	Not exceeding 14 days
10. Stoppage of leave	Not exceeding 14 days
13. Extra work or drill	Not exceeding 7 days and for not longer than two hours in one day.
14. Reprimand	
(iv) <i>Executive officer (if of the rank of lieutenant or above) when delegated with powers of punishment by the commanding officer.</i>	
<i>Punishment</i>	<i>Qualification</i>
9. Extra work and drill	Not exceeding 7 days
10. Stoppage of leave	Not exceeding 7 days but not to chief petty officers or petty officers if executive officer is below the rank of commander
13. Extra work or drill	Not exceeding 7 days and for not longer than two hours in one day
14. Reprimand	
(v) <i>Officer of the watch or day (if of the rank of lieutenant or above) when delegated with power of punishment by commanding officer, or a departmental officer of the rank of lieutenant or above when delegated with power by commanding officer to punish any rating of his department for an offence in connection with the duties of that department but not connected with the general duties of the ship or naval establishment</i>	
13. Extra work or drill	For one day only and for not longer than two hours on that day

FIRST SCHEDULE—*continued*

## B. Warrant Punishment

*Punishments No. 1 to No. 7 above inclusive (which may be known as warrant punishments) shall not have effect unless a warrant is made out, approved as required by the Schedule and formally read to the accused in public*

C. Approval of warrants is required as follows :—

<i>Punishment</i>	<i>Approving Authority</i>
1. Imprisonment .. ..	The Commander
2. Dismissal .. ..	The Commander
3. Detention .. ..	The Commander
4. Disrating .. ..	The commander if in Nigerian waters or if on detached service an officer of captain's rank or above in the case of a Petty Officer or a leading seaman
5. Reduction to 2nd class for conduct	The commander if in Nigerian waters or if on detached service an officer of the rank of commander or above
6. Deprivation of Loyal Service Medal	The commander
7. Deprivation of good conduct badges	The commander if in Nigerian waters ; if on detached service, an officer of the rank of commander or above may approve the deprivation of one good conduct badge.

## SECOND SCHEDULE

## Section 102

*Alternative Offences of which Accused may be convicted by Court Martial*

<i>Offence Charged</i>	<i>Alternative Offence</i>
1. Communicating with or giving intelligence to the enemy, either with intent to assist the enemy or without authority	1. Disclosing information without authority
2. Any offence against subsection (1) of section forty-two	2. Any offence against subsection (2) of section forty-two
3. Striking his superior officer	3. (a) Using violence to his superior officer otherwise than by striking him, or (b) Offering violence to his superior officer.

SECOND SCHEDULE—*continued*

<i>Offence Charged</i>	<i>Alternative Offence</i>
4. Using violence to his superior officer otherwise than by striking him	4. Offering violence to his superior officer
5. Using threatening language to his superior officer	5. (a) Using insolent language to his superior officer, or (b) Behaving with contempt to his superior officer
6. Using insolent language to his superior officer	6. Behaving with contempt to his superior officer
7. Disobeying, in such a manner as to show wilful defiance of authority, a lawful command given or sent to the accused personally	7. Behaving with contempt to his superior officer
8. Desertion	8. Absence without leave
9. Attempting to desert	9. Absence without leave
10. Stealing any property	10. Fraudulently misapplying the property
11. Any offence under section sixty-three involving wilfulness	11. The corresponding offence involving negligence
12. Any offence against subsection (1) of section sixty-seven	12. Any offence against subsection (2) of section sixty-seven
13. Any offence against section sixty-eight involving striking	13. The corresponding offence involving the offering of violence
14. Any offence against section sixty-eight involving the use of violence other than striking	14. The corresponding offence involving the offering of violence

## THIRD SCHEDULE

*Section 213**Transitional Provisions*

1. In this Schedule "the old Act" means the Royal Nigerian Navy Act, 1960, repealed by this Act.

2.—(1) In relation to an offence against any section in Part V of the old Act or against Part I of the Naval Discipline Act, 1957, sections eighty-three to one hundred and twenty-two inclusive, sections one hundred and twenty-nine to one hundred and thirty-two inclusive and sections one hundred and thirty-five and one hundred and thirty-six and section one hundred and eighty-two of this Act shall apply as if

THIRD SCHEDULE—*continued*

the said section of the old Act had been contained in this Act and this Act had been in force when the offence was committed, and as if any finding or punishment having effect before the date upon which this Act comes into operation, and anything done before that day by virtue of or in relation to such a finding or sentence, had been come to, awarded or done under this Act :

Provided that nothing in this sub-paragraph shall render an offence capable of being tried by court martial or dealt with summarily, if by reason of the time or place of the commission of the offence it could not have been so tried or dealt with under the old Act.

(2) Notwithstanding anything in sub-paragraph (1) of this paragraph where any proceedings for such an offence as aforesaid have been begun before the date upon which this Act comes into operation, any step in the proceedings taken after that day shall be deemed to be validly taken if taken in accordance with the old Act and the rules made thereunder.

(3) In section one hundred and forty-seven of this Act (which provides against trial for offences already disposed of), references to this Act or to any provision thereof shall be construed as including respectively references to the old Act and to the corresponding provision thereof.

3. Where after the date upon which this Act comes into operation a person is alleged—

(a) to have committed an offence continuing over a period beginning before that day and ending thereon or thereafter ; or

(b) to have committed an offence between two dates falling within such a period,

and the offence would be one against a provision in Part IV of this Act if it had been in operation at all material times, he may be proceeded against as if this Act had so been in operation.

4. Any officer who immediately before the date upon which this Act comes into operation was authorised to recruit or attest ratings shall, without prejudice to any subsequent withdrawal of the authorisation, be deemed without further authorisation a recruiting officer for the purposes of Part III of this Act.

5. Any document made before the date upon which this Act comes into operation which would have been admissible in evidence under the provision of the old Act, or those provisions as applied by any other enactment, shall be admissible to the like extent and in the like proceedings notwithstanding that the old Act has ceased to be in operation.

6. Any forfeiture of, or deduction from, pay having effect under the old Act immediately before the date upon which this Act comes into operation shall continue to have effect notwithstanding the repeal of the old Act.

## FOURTH SCHEDULE

Section 215

*Enactments Repealed*

<i>Chapter or number</i>	<i>Short title</i>	<i>Extent of repeal</i>
1960 No. 9	The Royal Nigerian Navy Act, 1960	The whole Act.
No. 31 of 1959	Nigerian Navy (Change of Title) Act, 1959.	The whole Act.
Cap. 128	The Navy Discipline Act.	The whole Act.
Cap. 131	Nigeria Naval Defence Force Act.	The whole Act.

EXCISE (CONTROL OF DISTILLATION)  
ACT, 1964

A 269



1964, No. 22

ARRANGEMENT OF SECTIONS

*Section*

- |  |   |
|--|---|
| <ol style="list-style-type: none"><li>1. Distiller's licence.</li><li>2. Still licence.</li><li>3. Regulations.</li><li>4. Making of entries.</li><li>5. New or further entries of same premises.</li><li>6. Proof as to entries.</li><li>7. Offences in connection with entries.</li><li>8. Power to enter for inspection purposes.</li><li>9. Power to search for concealed pipes, etc.</li><li>10. Power to prohibit use of certain substances in excisable goods.</li><li>11. Payment of duty by excise traders.</li><li>12. Liability of ostensible owner.</li><li>13. Effect of variation in balances struck or excess etc. in stock of materials.</li><li>14. Power to enter on premises etc. in cases of unlawful distillation.</li><li>15. Power to seize goods in particular cases.</li><li>16. Forfeiture and condemnation of spirits seized.</li></ol> | <ol style="list-style-type: none"><li>17. Power to levy distress.</li><li>18. Power to require excise control facilities.</li><li>19. Licensees to keep record books.</li><li>20. Power to require information etc. from licensees.</li><li>21. Unlawful assumption of office.</li><li>22. Officers to have powers of police officers.</li><li>23. Offences as to concealing etc. of spirits on licensed premises.</li><li>24. Condemnation proceedings.</li><li>25. Compensation in special cases.</li><li>26. Interpretation.</li><li>27. Repeals, etc.</li><li>28. Short title, extent, and operation.</li></ol> |
|--|---|

SCHEDULES :

First Schedule—Provisions Relating to Forfeiture.

Second Schedule—Form of Warrant of Distress.

Third Schedule—Enactments Repealed or Affected.



## 1964, No. 22

AN ACT TO MAKE OTHER PROVISION FOR THE CONTROL AND LICENSING FOR  
EXCISE PURPOSES OF THE DISTILLATION OF SPIRITS

[Section 28 (2)]

Commence-  
ment.

BE IT ENACTED by the Legislature of the Federation of Nigeria in this present Parliament assembled and by the authority of the same as follows :—

1.—(1) Subject to the provisions of this Act, no person shall without a distiller's licence under this section make or distil spirits; and application for such licence shall be made to the Board of Customs and Excise in the prescribed manner.

Distiller's  
licence.

(2) If the Board after due enquiry is satisfied that the premises mentioned in the application and intended to be used by the applicant for the purposes of distillation are in such a state that proper control for excise purposes may be exercised over activities to be carried on therein it shall, on payment of the sum of one hundred pounds issue to the applicant a distiller's licence in the prescribed form in respect of such premises.

(3) If the Board is not so satisfied and refuses the application it shall notify the applicant of its refusal, and give to the applicant particulars of what the Board considers necessary to be done to the premises.

(4) If at any time during the currency of a distiller's licence the Board is satisfied that proper control for excise purposes can no longer be exercised over the premises specified in the distiller's licence by reason of the state of the premises, or that the person to whom such licence was issued has ceased to make spirits on such premises, it may revoke the distiller's licence and give notice of the revocation in the prescribed manner.

(5) Any person who makes or distils spirits contrary to the provisions of subsection (1) of this section shall be guilty of an offence, and liable—

(a) on summary conviction to a fine of not less than two hundred pounds or more than five hundred pounds or to imprisonment for a term of two years, or to both;

(b) on conviction on indictment to a fine of an unlimited amount or to imprisonment for a term not exceeding five years or to both, and any spirits so distilled shall be liable to forfeiture.

(6) The provisions of this section shall, in any Region or the Federal territory be in addition to and not in substitution for any other provisions in force therein which affect the making of spirits, and nothing in the foregoing provisions of this section shall be construed as purporting to authorise the carrying on in any Region or the Federal territory of any activity which is prohibited by the law thereof.

Still  
licence.

2.—(1) Subject to the provisions of this section, no person shall possess any still unless—

(a) the still is situated on premises specified in a distiller's licence; or

(b) there is in force a still licence issued to him by the Board under this section.

(2) Where an application is made to the Board in the prescribed manner for the issue of a still licence, and the Board is satisfied, it shall issue the licence to the applicant free of charge.

(3) A licence under subsection (2) of this section may be issued subject to such conditions not inconsistent with this Act as to methylation or the denaturing of spirits as the Board for the protection of excise duty may think fit.

(4) If a person gives notice to the Board in the prescribed form of his intention to part with or that he has parted with possession of, or has destroyed any still in respect of which a licence issued to him under this section is in force, the Board shall make such enquiries as it thinks fit; and if it is satisfied, the licence shall cease to have effect as regards the still.

(5) Any person contravening the provisions of subsection (1) of this section shall be guilty of an offence and liable—

(a) on summary conviction, to a fine of not less than two hundred pounds or to imprisonment for a term of six months, or to both;

(b) on conviction on indictment, to a fine not less than one thousand pounds or to imprisonment for a term of two years, or to both.

Regulations.

3.—(1) The Minister may make such regulations with respect to the conduct of premises specified in a distiller's licence under this Act as appear to the Minister to be appropriate for the purpose of ensuring the payment of excise duty on spirits made on the premises; and without prejudice to the generality of the powers conferred by this subsection, regulations may in particular provide for—

(a) prohibiting or restricting the carrying on on the premises or particular parts thereof of such activities as may be prescribed;

(b) regulating the manner in which and the period during which any activity may be carried on on the premises or particular parts thereof;

(c) providing for the inspection by officers of the Board of the premises and all activities carried on on the premises;

(d) requiring notice to be given of any change or use which may be made of the premises or any part thereof;

(e) regulating the removal of spirits from the premises;

(f) prescribing the form of application for and of the distiller's licence to be used for the purposes of this Act,

and the regulations may provide for the imposition of penalties in respect of any offence against the regulations (not less than one hundred pounds or more than five hundred pounds in respect of any particular offence or to imprisonment for a term of two years, or to both) and for the forfeiture or disposal of any thing in respect of which such an offence is committed.

(2) The Minister may make such regulations with respect to the custody and use of stills licensed under this Act and the application for and form of any such licence, as appear to the Minister to be appropriate for the purpose of ensuring that the stills are not used to make spirits; and without prejudice to the generality of the powers so conferred, regulations may, in particular, contain provisions requiring the furnishing of information with respect to—

- (a) any change or proposed change in the location or use of stills;
- (b) the disposal of stills or any part of a still by way of sale or otherwise;

and the regulations may provide for the imposition of fines for offences against the regulations not less than fifty pounds or more than two hundred pounds in the case of any particular offence.

4.—(1) Where by or under any excise laws a person is required to make entry of any premises or article—

Making of entries.

(a) the entry shall be made in such form and manner and contain such particulars; and

(b) the premises or article shall be, and be kept, marked in such manner,

as the Board may direct.

(2) No entry shall be valid unless the person by whom it was made—

(a) had at the time of its making attained the age of twenty-one years; and

(b) was at that time and is for the time being a true and real owner of the trade in respect of which the entry was made.

(3) Where any person required to make entry is a body corporate—

(a) the entry shall be signed by a director, general manager, secretary or other similar officer of the body and, except where authority for that person to sign has been given under the seal of the body, shall be made under that seal; and

(b) both the body corporate and the person by whom the entry is signed shall be liable for all duties charged in respect of the trade to which the entry relates.

(4) If any person making entry of any premises or article contravenes or fails to comply with any direction of the Board given under this section with respect thereto, he shall be guilty of an offence punishable on conviction by a fine of one hundred pounds.

5.—(1) The Board may at any time, by notice in writing to the person by whom any existing entry was signed addressed to him at any premises entered by him, require a new entry to be made of any premises or article to which the existing entry relates, and the existing entry shall, without prejudice to any liability incurred, become void at the expiration of fourteen days from the delivery of the notice.

New or further entries of same premises.

(2) Save as permitted by the Board and subject to such conditions as it may impose, no premises or article of which entry has been made by any person shall, while that entry remains in force, be entered by any other person for any purpose of the excise laws, and any entry made in contravention of this subsection shall be void.

(3) Where the person by whom entry has been made of any premises absconds or quits possession of the premises and discontinues the trade in respect of which the entry was made, and the Board permits a further entry to be made of the premises by some other person, the former entry shall be deemed to have been withdrawn and shall be void.

Proof as to entries.

6. For the purpose of any proceedings before any court, if any question arises as to whether or not entry under the excise laws has been made by any person, or of any premises or article, or for any purpose, then—

(a) if a document purporting to be an original entry made by the person, or of the premises or article, or for the purpose, in question is produced to the court by an officer, that document shall, until the contrary is proved, be sufficient evidence that the entry was so made; and

(b) if the officer in whose custody any such entry, if made, would be, gives evidence that the original entries produced by him to the court constitute all those in his custody and that no such entry as is in question is among them, it shall be deemed, until the contrary is proved, that no such entry has been made.

Offences in connection with entries.

7.—(1) If any person being the holder of a licence under this Act uses, for any purpose of his trade, any premises or article required by or under the excise laws to be entered for that purpose without entry having been duly made thereof, he shall be guilty of an offence punishable on conviction by a fine of two hundred pounds, and any goods found on any such premises shall be liable to forfeiture.

(2) If any person who has made entry of any premises or article fraudulently uses those premises or that article for any purpose other than that for which entry was made thereof he shall be liable to a fine of two hundred pounds.

Power to enter for inspection purposes.

8.—(1) An officer may at any time enter upon any premises referred to in any licence under this Act for the purpose of inspecting the premises and may search for, examine and take account of any equipment, vessels, utensils, goods or materials belonging to or in any way connected with distillation.

(2) Where an officer, after having demanded admission into any such premises and declared his name and business at the entrance thereof is not immediately admitted, that officer and any person acting in his aid may break open any door or window of the premises or break through any wall thereof for the purpose of obtaining admission.

Power to search for concealed pipes, etc.

9.—(1) If an officer has reasonable ground to suspect that any secret pipe or other means of conveyance, cock, vessel or utensil is kept or used by a licensee under this Act, that officer may at any time, but by night only in the company of a police officer, break open any part of the premises of that trader and forcibly enter thereon, and so far as is reasonably necessary break up the ground in or adjoining those premises or any wall thereof to search for that pipe or other means of conveyance, cock, vessel or utensil.

(2) If the officer finds any such pipe or other form of conveyance leading to or from the licensee's premises, he may enter any other premises from or into which it leads, and so far as is reasonably necessary break up any part of those other premises to trace its course, and may

cut it away and turn any cock thereon, and examine whether it conveys or conceals any goods chargeable with a duty of excise, or any materials used in the manufacture of such goods, in such manner as to prevent a true account thereof from being taken.

(3) Every such pipe or other means of conveyance, cock, vessel or utensil as aforesaid, and all goods chargeable with a duty of excise or materials for the manufacture of such goods found therein, shall be liable for forfeiture, and the licensee shall be guilty of an offence punishable on conviction by a fine of one hundred pounds.

(4) If any damage is done in any such search as aforesaid and the search is unsuccessful, the Board shall make good the damage.

10.—(1) If it appears to the satisfaction of the Board that any substance or liquor is used, or is capable of being used, in the manufacture or preparation for sale of any goods chargeable with a duty of excise, and that that substance or liquor is of a noxious or detrimental nature or, being a chemical or artificial extract or product, may affect prejudicially the interests of the revenue, the Board may by notice in the *Gazette* prohibit the use of that substance or liquor in the manufacture or preparation for sale of any goods specified in the notice.

Power to prohibit use of certain substances in excisable goods.

(2) If while any such notice is in force any person knowingly uses a substance or liquor thereby prohibited in the manufacture or preparation for sale of any goods specified in the regulations he shall be guilty of an offence punishable on conviction by a fine of fifty pounds.

(3) Any substance or liquor the use of which is for the time being prohibited by any such notice found in the possession of any person licensed for the manufacture or sale of any goods specified in the notice, and any goods in the manufacture or preparation of which any substance or liquid has been used contrary to any such prohibition, shall be liable to forfeiture.

11.—(1) Every licensee shall pay any duty of excise payable in respect of his trade at or within such time, at such place and to such person as the Board may direct, whether or not payment of that duty has been secured by bond or otherwise.

Payment of duty by excise traders.

(2) If any duty payable is not paid as aforesaid, it shall be paid on demand made by the Board either to the licensee personally or by delivering the demand in writing at his place of abode or business, and if it is not so paid on demand the licensee shall in addition be liable to a penalty of double the amount due.

12. Any person who acts ostensibly as the owner or who is a principal manager of the business of a licensee under this Act in respect of which entry of any premises or article had been made or who occupies or uses any entered premises or article shall, notwithstanding that he is under the age of twenty-one years, be liable in like manner as the real and true owner of the business for all duties charged and all penalties incurred in respect of that business.

Liability of ostensible owner.

Effect of variation in balances struck or excess etc. in stock of materials.

13. If at any time when an account is taken by the proper officer and a balance is struck—

(a) of the quantity of spirits in the possession of the distiller, that quantity differs from the quantity thereof which ought to be in his possession according to any account required by this Act to be kept,

(i) if the former quantity exceeds the latter the excess shall be liable to forfeiture, and

(ii) if the former quantity is less than the latter, the holder of the distiller's licence shall be liable to a fine of double the excise duty which would be payable on the quantity of pure alcohol equal to that on the deficiency ;

(b) of the stock of materials, any excess is found or goods not authorised for use as materials are discovered in the stock, such excess or goods shall be liable to forfeiture ;

(c) of the stock of materials, any deficiency is found which cannot be accounted for to the satisfaction of the Board, the quantity or value of materials representing such deficiency shall be deemed to have been used in manufacture and, in any particular case, duty shall be charged on the quantity or value of excisable goods reckoned to have been produced with such quantity or value of materials.

Power to enter on premises etc. in cases of unlawful distillation.

14. If any officer has reasonable grounds to suspect that distillation contrary to the provisions of this Act is being carried out on any land or premises, he may enter thereon, if need be by force, and dismantle or seize the still or other apparatus used in conjunction therewith.

Power to seize goods in particular cases.

15. Where spirits subject to excise duty become liable to forfeiture under this Act but spirits are not available in sufficient quantity for forfeiture, the Board may seize from the stock of the licensee, any quantity of spirits available or goods capable of conversion into spirits of such quantity, as would attract up to the same amount of duty as that on the spirits liable to forfeiture.

Forfeiture and condemnation of spirits seized.

16.—(1) In the application of this section the provisions of the First Schedule to this Act shall have effect for the purposes of forfeiture, and all proceedings for the condemnation of any thing as being forfeited, under the excise laws.

(2) Any officer, police officer, or person authorised in that behalf by the Board, may at any time seize or detain any spirits liable to forfeiture under this Act or which such officer, police officer or person so authorised has reasonable grounds to believe is liable to forfeiture under the excise laws.

(3) Spirits so seized or detained shall forthwith be delivered to the Board ; and pending determination by the Board as to forfeiture or disposal, things delivered to the Board may be condemned as forfeited or otherwise dealt with as the Board may direct.

Power to levy distress.

17.—(1) Where any excise duty remains unpaid on spirits distilled under licence after the time within which the same is payable, the Board may authorise the levying of a distress,—

(a) upon the goods, chattels and effects of the licensee in respect of which the duty remains unpaid ; and

(b) upon all equipment, plant, tools, ships, vehicles, animals, goods and effects used in the distillation, sale or distribution of spirits found in any premises or on any land in the use or possession of such manufacturer or of any person on his behalf, or in trust for him.

(2) The authority to distrain under this section shall be in the form in the Second Schedule to this Act, and shall be a warrant and authority to levy by distress the amount of any duties due.

(3) For the purpose of levying any distress under this section, any person authorised in writing by the Board may execute a warrant of distress and if necessary break open any building or place in the daytime for the purpose of levying such distress. The person so authorised may call to his assistance any police officer, who shall when required aid and assist in the execution of the warrant of distress and in levying the distress.

(4) Where distraint is made, the burden of proof that they are not liable to seizure shall lie upon the person claiming they are not so liable, and any goods or things seized may, at the cost of the owner thereof, be kept for fourteen days; and if the amount due in respect of duty and the cost and charges of and incidental to the distress are not then paid, the goods or things so seized may be sold.

(5) Out of the proceeds of the sale there shall be paid first the excise duty and thereafter the costs or charges of and incidental to the sale and keeping of the distress; and the residue, if any, shall be paid to the owner of the goods or things distrained, upon demand made by the owner within one year of the date of sale.

(6) In exercise of the power of distress conferred by this section, the person to whom authority to levy duties is given may distrain upon all goods or things belonging to the licensee wherever the same may be found.

18.—(1) The holder of a licence shall provide and maintain at his own expense on premises referred to in the licence,—

(a) such office, lavatory and sanitary accommodation, with the requisite furniture, lighting and cleaning, as the Board may reasonably require for the use of the proper officer under this Act; and

(b) such appliances and facilities as may be required to enable the proper officer at any time to examine, or search or to perform any other of his duties at such premises as the Board may direct;

and if the licensee fails to comply with any of the foregoing requirements of this subsection, the Board may revoke or suspend any such licence.

(2) The requirements which the Board is authorised to impose on the holder of a licence by subsection (1) of this section shall include the requirement to provide at his own expense and lease to the Board, on such reasonable terms as the Board may determine, living accommodation which the Board considers suitable for occupation by, and by the household of, any officer charged with duties which, in the opinion of the Board, make it desirable that he should reside on or near the premises for which the excise licence in question is granted; and the provisions of that subsection for failure to comply therewith shall have effect accordingly.

Power to  
require  
excise  
control  
facilities.

(3) The proper officer may affix a lock or seal to any fitting on the premises or on any apparatus or thing whatsoever therein and for such purpose he may require the holder of a distiller's licence to provide and maintain at his own expense any such fitting. If such licensee fails to comply with the requirements of this subsection, the Board may provide and install the fitting, and any expense incurred shall be paid on demand by the licensee. The failure to pay any such expense shall be an offence for which the offender shall, in addition to the requirement of payment of any such expense, be liable on summary conviction to a fine of one hundred pounds.

(4) If the holder of a distiller's licence or any member of his family or any servant of the holder—

(a) wilfully destroys or damages a fitting or any lock, key or seal intended for use therewith ; or

(b) improperly obtains access to any place or article secured by any such lock or seal thereon ; or

(c) has any fitting on premises or on any apparatus or thing whatsoever fastened or attached in such fashion that adequate supervision and control by any proper officer for the purposes of this Act is not practicable ;

the holder, or member of his family, or the servant, as the case may be, shall on conviction be liable to a fine of five hundred pounds.

Licensees to  
keep record  
books.

19.—(1) Every holder of a distiller's licence shall keep on the premises mentioned in the licence such records and make all entries therein relating to the manufacture, storage and delivery of spirits and materials as the Board may require. Entries shall be made legibly in ink and no cancellation or amendment shall be made save in such manner as the Board may from time to time direct. If the Board requires records to be kept, the proper officer may inspect them at any time and take copies of any entry.

(2) The failure to comply with the requirements of this section shall be an offence for which the offender shall be liable on summary conviction to a fine of two hundred pounds.

Power to  
require  
information  
etc. from  
licensees.

20.—(1) The holder of any licence under this Act shall—

(a) produce to the Board for inspection as and when required invoices and other books or documents in his possession relating to spirits manufactured by him during the preceding twelve months or any part thereof ;

(b) supply answer to questions relating to the distillation of spirits and related matters as the Board may reasonably require to implement the provisions of any of the excise laws ;

(c) produce to the Board such evidence as it may reasonably require in support of any answer so given ;

(d) make returns in such form and at such intervals as the Board may require ;

and if any manufacturer fails without lawful excuse to comply with any requirement of this subsection, he shall be liable on summary conviction to a fine of one hundred pounds.

(2) The powers conferred on the Board by subsection (1) of this section, in so far as they relate to questions regarding the cost of production and manufacturer's profits in respect of any spirits, shall be exercisable by the Board alone and not by any other person.

(3) The Board may require the holder of a licence under this Act to supply to it in every year or at such other times as it may direct, a certificate of audit by an accountant approved by the Board as to—

(a) the correctness of all the books and records required by or under this Act to be kept by the holder of the licence ; and

(b) any matter necessary to implement the provisions of any of the excise laws ;

and the holder of a licence who without reasonable excuse fails to supply a certificate of audit when required shall be liable on summary conviction to a fine of one hundred pounds.

(4) For the purpose of this section "accountant approved by the Board" means an accountant who is a member of one of the professional bodies for the time being declared by the Board, by notice in the Gazette, to be approved for such purposes, but does not include any such member if he is the holder of a licence under this Act or is employed by any such holder.

21. If for any of the purposes incidental to the control of distillation under this Act any person without lawful authority assumes the name, designation or character of an officer he shall, in addition to any other punishment, be liable on conviction to a fine of not less than two hundred pounds or more than five hundred pounds, or to imprisonment for a term of two years, or to both.

Unlawful assumption of office.

22. For the avoidance of doubt, officers acting under this Act shall have the same powers, authorities and privileges as are given by law to police officers.

Officers to have powers of police officers.

23. If any person—

(a) conceals any spirits on premises mentioned in a distiller's licence, or

(b) without the consent of the proper officer removes any spirits from such premises, or

(c) knowingly buys or receives any spirits so concealed or removed, or

(d) knowingly possesses, buys, or receives any spirits removed from such premises before duty (if any) has been charged and as the case may be, paid or secured,

Offences as to concealing etc. of spirits on licensed premises.

the spirits shall be liable to forfeiture ; and such person shall on conviction be liable to a fine of six times the value of the goods to two hundred pounds whichever is the greater, or to imprisonment for two years, or to both.

24.—(1) Where, in any proceedings for the condemnation of any thing seized as liable to forfeiture under this Act judgment is given for the claimant, the court before which the case is heard may, if it sees fit, certify that there were reasonable grounds for the seizure.

Condemnation proceedings.

(2) Where any proceedings, whether civil or criminal, are brought against the Board or any person authorised by or under this Act to seize or detain anything liable to forfeiture on account of the seizure or detention or anything, and judgment is given for the plaintiff or prosecutor, then if—

(a) a certificate relative to the seizure has been granted under subsection (1) of this section ; or

(b) the court is satisfied that there were reasonable grounds for seizing or detaining that thing under the excise laws, the plaintiff or prosecutor shall not be entitled to recover any damages or costs and the defendant shall not be liable to any punishment :

Provided that nothing in this subsection or in the next succeeding section shall affect the right of any person to the return of the thing seized or detained or to compensation in respect of any damage to the thing or in respect of the destruction thereof.

(3) Any certificate under subsection (1) may be proved by the production of either the original certificate or a certified copy thereof purporting to be signed by an officer of the court by which it was granted.

Compensation in special cases.

25.—(1) Where any spirits on the premises of the holder of a licence under this Act are destroyed, stolen or unlawfully removed by or with the assistance or connivance of an officer, and that officer is convicted of the offence the Board shall, if the licensee was not a party to the offence, pay compensation for any loss caused by any such destruction, theft or removal ; and it is hereby declared that in any such case no duty shall be payable on any such spirits by the licensee, and duty (if any) paid thereon by the licensee shall be refunded.

(2) Subject to the provisions of the foregoing subsection, compensation shall not be payable by the Board, and no action shall lie against the Board or any officer for any loss or damage caused to any goods by any officer acting in the execution of his duty except where the loss or damage occurs as the direct result of the unlawful act or negligence of such officer or arises out of any unsuccessful search to which subsection (4) of section nine of this Act applies.

Interpretation.

26. In this Act unless the context otherwise requires—

“the Board” means the Board of Customs and Excise ;

“distiller’s licence” means a licence to distill spirits granted under section one of this Act ;

“excise laws” means the Customs and Excise Management Act, 1958 and includes any other Act relating to the control of excisable goods ;

“officer” means any person employed in the Department of Customs and Excise, or for the time being performing customs or excise duties ;

“proper officer” means any officer whose right or duty it is to require the performance of or do an act ;

“pure alcohol” means spirits by volume at fifteen point five six degrees Centigrade or sixty degrees Fahrenheit ;

No. 55 of 1958.

“spirits” means ethyl alcohol and includes all liquors mixed with or compounded with or prepared from ethyl alcohol, but does not include undistilled fermented liquors containing twenty per centum or less of pure ethyl alcohol ;

“still” means any apparatus used or capable of being used to produce spirits by distillation ;

“still licence” means a licence granted for the purposes of section two of this Act.

27.—(1) The enactment mentioned in Part A of the Third Schedule to this Act is hereby repealed to the extent therein specified.

Repeals etc.

(2) Where by any enactment reference is made to excise legislation in relation to spirits or to distillation of spirits in Nigeria, the spirits and any equipment shall, for excise purposes, be deemed to be affected by this Act ; and references shall be so construed, and the enactments mentioned in Part B of the Third Schedule shall have effect accordingly.

No. 55 of  
1958.

(3) Any law in force in any Region, other than an enactment repealed by subsection (1) of this section, or a provision of the Customs and Excise Management Act, 1958, or of an instrument having effect by virtue of that Act, is hereby repealed in so far as it makes provision with respect to the importation of stills.

28.—(1) This Act may be cited as the Excise (Control of Distillation) Act, 1964, and shall apply throughout the Federation.

Short title,  
extent, and  
operation.

(2) This Act shall come into operation on a day to be appointed by the Minister by order in the Gazette.

## SCHEDULES

## FIRST SCHEDULE

Section 16 (1)

## PROVISIONS RELATING TO FORFEITURE

*Notice of Seizure*

1.—(1) Save where seizure was made in the presence of—

(a) the person whose offence or suspected offence occasioned the seizure, or

(b) the owner or any of the owners of the thing seized or any servant or agent of his,

the Board shall give notice of the seizure of any thing as liable to forfeiture and of the grounds therefor to any person who to its knowledge was at the time of the seizure the owner or one of the owners thereof.

(2) Notice under this paragraph shall be given in writing and shall be deemed to have been duly served on the person concerned—

(a) if delivered to him personally ;

(b) if addressed to him and left or forwarded by post to him at his usual or last known place of abode or business or, in the case of a body corporate, at their registered or principal office ;

(c) in any other case, by publication of notice of seizure in the Gazette.

*Notice of Claim*

2.—(1) Any person claiming that any thing seized as liable to forfeiture is not so liable shall, within one month of the date of the notice of seizure, or, if no such notice has been served on him, within one month of the date of the seizure, give notice of his claim in writing to the Board :

Provided that the Board may, at its discretion, extend the period in which notice of a claim may be given.

(2) The notice shall specify the name and address of the claimant. If a claimant is outside Nigeria the notice shall specify the name and address of a legal practitioner in Nigeria authorised to accept the service of process and to act on behalf of the claimant and where service is affected on such legal practitioner it shall be deemed to be proper service upon the claimant.

*Condemnation*

3. If on the expiration of the relevant period aforesaid for the giving of notice of claim no such notice has been given to the Board, or if, in the case of any such notice given, any requirement of paragraph 2 is not complied with, the thing in question shall be deemed to have been duly condemned as forfeited.

4. Where notice of claim is duly given in accordance with the foregoing provisions of this Schedule, the Board shall take proceedings for the condemnation of that thing by the court, and if the court finds that the thing was at the time of seizure liable to forfeiture, the court shall condemn it as forfeited.

5. Where any thing is in accordance with either of the two last foregoing paragraphs condemned or deemed to have been condemned as forfeited then, without prejudice to any delivery by or sale of the thing by the Board under paragraph 12, the forfeiture shall have effect as from the date when the liability to forfeiture arose.

*Proceedings for Condemnation by Court*

6. Proceedings for condemnation shall be civil proceedings and may be instituted in the same courts as those in which proceedings may be instituted by the Board in respect of things liable to forfeiture and seized accordingly under the provisions of the excise laws.

7. In any proceedings for condemnation, if the claimant or his legal practitioner fails to make oath that the thing seized was, or to the best of his knowledge or belief was, the property of the claimant at the time of the seizure, the court shall give judgment for the Board.

8. If in condemnation proceedings an appeal is lodged against the decision of the court, things seized shall, pending the final determination of the matter, be left in the custody of the Board.

*Provisions as to Proof*

9. In any proceedings arising out of the seizure of any thing, the effect, form and manner of the seizure shall be taken to have been as set forth in the process without any further evidence thereof, unless the contrary is proved.

10. In any proceedings, the condemnation by a court of any thing as forfeited may be proved by the production either of the order or certificate of condemnation or a certified copy thereof purporting to be signed by an officer of the court by which the order or certificate was made or granted.

*Special Provisions as to certain Claimants*

11. For the purposes of a claim to, or proceedings for the condemnation of, any thing, where that thing is at the time of the seizure the property of a body corporate, of two or more partners or of any number of persons exceeding five, the oath required by this Schedule to be taken and anything required by this Schedule or by the rules of the court to be done by, or by any other person authorised by, the claimant or owner may be taken or done by, or by any other person authorised by, the following persons respectively, that is to say—

(a) where the owner is a body corporate, the secretary or some duly authorised officer of that body ;

(b) where the owners are in partnership, any one of those owners ;

(c) where the owners are any number of persons exceeding five, not being in partnership, any two of those persons on behalf of themselves and their co-owners.

12. Where any thing has been seized as liable to forfeiture, the Board may at any time, at its discretion, and notwithstanding that the thing has not yet been condemned or is not yet deemed to have been condemned as forfeited—

(a) deliver it up to any claimant upon his paying to the Board such sum as the Board thinks proper, being a sum not exceeding that which, in its opinion, represents the value of the thing, including any duty chargeable thereon which has not been paid ; or

(b) if the thing seized is in the opinion of the Board of a perishable nature, sell or destroy it.

13.—(1) Subject to the provisions of this paragraph, if in the case of any thing delivered up, sold or destroyed as aforesaid, it is held in proceedings taken under this Schedule that the thing was not liable to forfeiture at the time of its seizure, the Board shall on demand by the claimant tender to him—

(a) an amount equal to any sum paid by him under sub-paragraph (a) of paragraph 12 ; or

(b) where the Board has sold the thing, an amount equal to the proceeds of sale ; or

(c) where it has destroyed the thing, an amount equal to the market value of the thing at the time of its seizure.

(2) If any such amount includes any sum on account of duty chargeable on the thing which had not been paid before its seizure, the Board may deduct so much of that amount as represents that duty.

(3) If the claimant accepts any amount tendered to him under this paragraph, he shall not be entitled to maintain any action on account of the seizure, detention, sale or destruction of the thing.

## SECOND SCHEDULE

Section 17 (2)

### FORM OF WARRANT OF DISTRESS

To .....

The Board of Customs and Excise, by virtue of the powers vested in it by section 17 of the Excise (Control of Distillation) Act, 1964, hereby authorises you to collect and recover the sum of.....

.....due for excise duty from.....  
.....(manufacturer),.....

having his premises at ..... ; and for the recovery thereof further authorises that you, with the aid (if necessary) of your assistants and calling to your assistance any police officer (if necessary), which assistance he is hereby required to give, do forthwith levy by distress the said sum together with the costs and charges of and incidental to the taking and keeping of such distress, on the goods, chattels or other distrainable things of the said manufacturer wherever the same may be found and on all equipment, plant, tools, ships, aircraft, vehicles, animals, goods and effects used within Nigeria in the manufacture, sale or distribution of excisable goods which you may find in any premises or on any land in the use or possession of the said manufacturer or of any person on his behalf or in trust for him.

And for the purpose of levying such distress you are hereby authorised, if necessary, with such assistance as aforesaid to break open any building or place in the daytime.

Signed for and on behalf of the Board of Customs and Excise

at.....this.....day of.....

19.....

Collector (or as the case may be)

### THIRD SCHEDULE

Section 27

#### PART A

#### Enactment repealed

<i>Number</i>	<i>Short title</i>	<i>Extent of repeal</i>
No. 55 of 1958	The Customs and Excise Management Act, 1958	Part V except sections 95 to 100

#### PART B

#### Enactments Affected

<i>Chapter or Number</i>	<i>Short title</i>	<i>Extent to which affected</i>
Cap. 105	The Liquor Act	So much of sections 8, 9, and 10 as relate to the distillation of spirits in the Regions, and of section 11 relating to the possession of metal tubing for use in connection with distillation of spirits in Nigeria
No. 49 of 1957	The Distillation of Spirits Act 1957	The whole Act



# APPROPRIATION ACT, 1964



1964, No. 23

AN ACT TO AUTHORISE THE ISSUE OUT OF THE CONSOLIDATED REVENUE FUND OF SIXTY-TWO MILLION TWO HUNDRED AND SEVENTY-FIVE THOUSAND NINE HUNDRED AND EIGHTY POUNDS FOR THE SERVICE OF THE YEAR ENDING ON THE THIRTY-FIRST DAY OF MARCH, ONE THOUSAND NINE HUNDRED AND SIXTY-FIVE; AND TO APPROPRIATE THAT AMOUNT FOR THE PURPOSES SPECIFIED IN THIS ACT.

[16th April, 1964]

Commence  
ment.

BE IT ENACTED by the Legislature of the Federation of Nigeria in this present Parliament assembled and by the authority of the same as follows :—

1.—(1) The Accountant-General may, when authorised so to do by warrants signed by the Minister of Finance, pay out of the Consolidated Revenue Fund during the year ending on the thirty-first day of March, one thousand nine hundred and sixty-five, the sums specified by the warrants, not exceeding in the aggregate Sixty-two million two hundred and seventy-five thousand nine hundred and eighty pounds.

Issue and  
appropriation  
of  
£62,275,980  
from Conso-  
lidated  
Revenue  
Fund for  
1964-65.

(2) The amount mentioned in the foregoing subsection shall be appropriated to heads of expenditure as indicated in the Schedule to this Act.

(3) No part of the amount aforesaid shall be issued out of the Consolidated Revenue Fund after the end of the year mentioned in subsection (1) of this Section.

2. This Act may be cited as the Appropriation Act, 1964, and shall apply throughout the Federation.

Short  
title and  
extent

Section 1	SCHEDULE						Amount
<i>Head</i>							£
21 State House	..	..	..	..	..	..	63,160
22 Cabinet Office	..	..	..	..	..	..	4,838,510
23 Police	..	..	..	..	..	..	6,234,060
24 Ministry of Commerce and Industry	..	..	..	..	..	..	844,830
25 Ministry of Communications	..	..	..	..	..	..	6,539,470
26 Ministry of Defence	..	..	..	..	..	..	409,340
27 Nigerian Army	..	..	..	..	..	..	5,376,490
28 Nigerian Navy	..	..	..	..	..	..	787,580
29 Nigerian Air Force	..	..	..	..	..	..	603,780
30 Ministry of Economic Development	..	..	..	..	..	..	621,320
31 Agriculture (Research)	..	..	..	..	..	..	319,900
32 Fisheries Service	..	..	..	..	..	..	66,580
33 Forestry (Research)	..	..	..	..	..	..	147,280
34 Veterinary (Research)	..	..	..	..	..	..	259,220
35 Statistics	..	..	..	..	..	..	315,910
36 Ministry of Education	..	..	..	..	..	..	2,270,360
37 Antiquities	..	..	..	..	..	..	87,500
38 National Archives	..	..	..	..	..	..	84,540
39 Ministry of Establishments and Service Matters	..	..	..	..	..	..	509,900
40 Pensions and Gratuities	..	..	..	..	..	..	813,750
41 Ministry of Finance	..	..	..	..	..	..	1,674,690
42 Board of Customs and Excise	..	..	..	..	..	..	887,370
43 Inland Revenue	..	..	..	..	..	..	248,960
44 Ministry of External Affairs	..	..	..	..	..	..	3,271,680
45 Ministry of Health	..	..	..	..	..	..	5,182,890
46 Ministry of Information	..	..	..	..	..	..	2,825,330
47 Ministry of Internal Affairs	..	..	..	..	..	..	313,390
48 Prisons	..	..	..	..	..	..	1,358,990
49 Ministry of Justice	..	..	..	..	..	..	312,390
50 Ministry of Labour	..	..	..	..	..	..	784,730
51 National Provident Fund	..	..	..	..	..	..	148,980
52 Ministry of Lagos Affairs	..	..	..	..	..	..	1,366,150
53 Ministry of Mines and Power	..	..	..	..	..	..	259,500
54 Geological Survey	..	..	..	..	..	..	140,030
55 Ministry of Transport	..	..	..	..	..	..	1,193,770
56 Coastal Agency	..	..	..	..	..	..	139,150
57 Inland Waterways	..	..	..	..	..	..	828,200
58 Ministry of Works and Surveys	..	..	..	..	..	..	6,845,500
59 Audit	..	..	..	..	..	..	109,440
60 Electoral Commission	..	..	..	..	..	..	29,630
61 Judicial	..	..	..	..	..	..	225,730
62 Parliament	..	..	..	..	..	..	750,900
63 Public Service Commission	..	..	..	..	..	..	65,480
64 Contributions to the Development Fund	..	..	..	..	..	..	1,350,000
65 Non-Statutory Appropriations of Revenue	..	..	..	..	..	..	769,620
Total	..	..	..	..	..	..	<u>£62,275,980</u>

REMOVAL OF VEHICLES ETC. (LAGOS)  
ACT, 1964



ARRANGEMENT OF SECTIONS

*Section*

1. Removal of vehicles from highways.
2. Provision of removed vehicle parks, etc. by the Council.
3. Reclaiming of removed vehicles.
4. Disposal by court of unreclaimed vehicles, etc.

5. Arrest without warrant of persons in charge of vehicles unlawfully used as taxis, etc.
6. Interpretation, etc.
7. Short title, extent and commencement.

1964, No. II

AN ACT TO PROVIDE FOR THE REMOVAL AND DISPOSAL OF VEHICLES LEFT ON HIGHWAYS ; FOR THE ARREST WITHOUT WARRANT OF PERSONS IN CHARGE OF VEHICLES APPEARING TO BE USED UNLAWFULLY AS HACKNEY OR STAGE CARRIAGES ; AND FOR PURPOSES CONNECTED WITH THE MATTERS AFORESAID.

[See section 7 (2)]

Commence-  
ment.

BE IT ENACTED by the Legislature of the Federation of Nigeria in this present Parliament assembled and by the authority of the same as follows :—

1.—(1) Where a motor vehicle is stationary on a highway, any police officer of or above the rank of inspector may, subject to subsection (3) of this section, cause the vehicle to be removed to a removed vehicle park if—

Removal of  
vehicles from  
highways.

(a) he has reasonable grounds for believing that the presence of the vehicle on the highway is in contravention of provisions of an enactment relating to the parking of vehicles ; and

(b) he is of the opinion that the contravention should be investigated ; and

(c) he has reasonable grounds for believing either—

(i) that the vehicle is not in a condition in which it can be moved under its own power ; or

(ii) that no person authorised to drive the vehicle is in or in the immediate vicinity of the vehicle.

(2) A person acting in pursuance of the foregoing subsection as respects any vehicle may use such force as may be reasonably necessary for the purpose of removing the vehicle or of gaining access to any part of it in order to facilitate the removal of the vehicle.

(3) Where a police officer has given instructions for the removal of a vehicle in pursuance of subsection (1) of this section but—

(a) the vehicle has not been moved from its position in pursuance of the instructions ; and

(b) a person claiming to be entitled to the custody of the vehicle gives to any person proposing to carry out the instructions an undertaking to remove it forthwith,

the instructions shall cease to have effect if the undertaking is fulfilled ; but except as provided by the foregoing provisions of this subsection a person claiming to be entitled to the custody of a vehicle in respect of which such instructions have been given shall not be entitled to recover the vehicle otherwise than in pursuance of the following provisions of this Act.

Provision of removed vehicle parks, etc. by the Council.

2.—(1) It shall be the duty of the Council—

(a) to provide and maintain places in Lagos to which vehicles may be removed in pursuance of the foregoing section (in this Act referred to as "removed vehicle parks"), and to secure that an official in charge of each park is at all times present in the park when removed vehicles are in it ;

(b) to provide suitable facilities (including equipment and persons to operate it) for the removal of vehicles in pursuance of the foregoing section ;

(c) to make reasonable arrangements for the safe-custody of removed vehicles while they are in removed vehicle parks ;

(d) to provide and maintain at the principal offices of the Council a record containing particulars of each removed vehicle and its contents and specifying the date of its removal, the park in which it is situated and whether an application in respect of the vehicle has been made to the court in pursuance of subsection (3) of section four of this Act ; and

(e) to keep the record open during normal office hours for inspection free of charge by members of the public.

(2) The Council shall not be under any duty to protect removed vehicles otherwise than as mentioned in paragraph (c) of the foregoing subsection, and in particular shall not be under a duty to protect removed vehicles from damage attributable to sun, rain, wind or other physical conditions.

Reclaiming of removed vehicles.

3.—(1) A person who tenders to the official in charge of a removed vehicle park—

(a) such evidence as may be prescribed of his entitlement to the custody of a removed vehicle which is in the park ; and

(b) the appropriate charges in respect of the vehicle and a receipt for the vehicle in the prescribed form,

shall, subject to the provisions of subsection (3) of this section and of any order under this Act previously made by the court, be entitled, on demand at the park at any time between the hours of eight o'clock in the morning and six o'clock in the following evening on any week-day (other than a public holiday) and with consent given on behalf of the Council at any other time, to have the vehicle delivered up to him at the park.

(2) In the foregoing subsection—

“appropriate charges”, in relation to a removed vehicle of any class means such sum as the Minister may by order specify as respects vehicles of that class ; and

“prescribed” means prescribed by regulations made by the Minister ; and the Minister shall so exercise his powers to make orders under this subsection as to secure that the sums specified by the orders will, in his opinion, not in the aggregate exceed the sums required, taking one year with another, to reimburse to the Council the cost of performing the functions imposed on the Council by this Act.

(3) Except so far as the court otherwise orders, subsection (1) of this section shall not apply in relation to a removed vehicle as respects which an application to the court has been made in pursuance of this Act.

4.—(1) If a removed vehicle is not disposed of in accordance with this Act within the period of one month beginning with the date on which it is removed in pursuance of this Act, the Council shall, as soon as reasonably practicable after the expiration of that period, cause to be published in two separate issues of the Gazette of the Federation, and of each of two daily newspapers circulating in Lagos, a notice containing particulars of the vehicle and stating that, unless the vehicle is otherwise disposed of in accordance with this Act before the expiration of the period of two months beginning with the date of the Gazette in which the notice is first published, the Council proposes to apply to the court for an order for the forfeiture of the vehicle to the Council.

Disposal by  
court of  
unreclaimed  
vehicles, etc.

(2) A person claiming to be entitled—

(a) to the benefit of a charge or lien on a removed vehicle apart from its contents ; or

(b) to, or to the benefit of a charge or lien on, any contents of a removed vehicle,

may at any time before the making of an application in respect of the vehicle in pursuance of the next following subsection, apply to the court for an order protecting his interest in the vehicle or the contents, as the case may be ; and on any such application the court may make such order as it considers just, including an order vesting the vehicle or its contents in any person on such terms as the court thinks fit.

(3) If, on an application in respect of a removed vehicle made by the Council after the expiration of the period of two months mentioned in subsection (1) of this section, the court is satisfied—

(a) that notices in accordance with that subsection have been published in respect of the vehicle ; and

(b) that immediately before the removal of the vehicle in pursuance of this Act its presence on the highway from which it was removed was in contravention of provisions of an enactment relating to the parking of vehicles ; and

(c) that no person claiming to be entitled to the custody of the vehicle or to any of its contents has taken the steps required by rules of court for the purpose of enabling him to oppose the application, or that every such person who has taken those steps has failed to establish his claim,

the court may order the forfeiture of the vehicle to the Council ; and where such an order is made in respect of a removed vehicle, the vehicle (including its contents) shall, subject to the provisions of any relevant order made in pursuance of the last foregoing subsection, vest in the Council free from encumbrances, and the Council may retain it or dispose of it as the Council thinks fit.

(4) Where, on an application made to the court in pursuance of the last foregoing subsection in respect of a removed vehicle, any such person as is mentioned in paragraph (c) of that subsection establishes his claim to be entitled to the custody of the vehicle or to any of its contents, the court may make such order as it considers just, including an order vesting the vehicle or its contents in any person on such terms as the court thinks fit.

(5) Any application to the court under this section shall be made in accordance with rules of court.

5. Without prejudice to any other power of arrest exercisable by a police officer, any police officer may arrest without a warrant a person who, within the view of the officer, acts as the driver of a motor vehicle or as the driver's assistant in such circumstances that the officer reasonably believes that the vehicle is being used in contravention of any enactment relating to permits or licences for the use of vehicles as hackney or stage carriages within the meaning of the Road Traffic Act.

6.—(1) In this Act the following expressions have the meanings hereby assigned to them respectively unless the context otherwise requires, that is to say—

“the Council” means the Lagos City Council ;

“the court” means the High Court of Lagos ;

“enactment” has the same meaning as in section twenty-seven of the Interpretation Act, 1964 ;

“the Minister” means the Minister of the government of the Federation responsible for relations with the Council ;

“motor vehicle” has the same meaning as in the Road Traffic Act ;

“removed vehicle” means a vehicle removed in pursuance of section one of this Act ; and

“removed vehicle park” has the meaning assigned to it by paragraph (a) of subsection (1) of section two of this Act.

(2) In this Act, references to a vehicle include references to any trailer or other thing attached to the vehicle and, except where the contrary intention appears and except in paragraph (a) of subsection (1) of section three, references to the contents of the vehicle.

(3) Nothing in this Act shall be construed as affecting the liability of any person to be convicted of or punished for an offence.

7.—(1) This Act may be cited as the Removal of Vehicles etc. (Lagos) Act, 1964, and shall apply to the Federal territory only.

(2) This Act shall come into force on such day as the Minister may by order appoint.

Arrest without warrant of persons in charge of vehicles unlawfully used as taxis etc.  
Cap. 184.

Interpretation, etc.

1964, No. 1.

Short title, extent and commencement.

## REGISTERED LAND ACT, 1964



## ARRANGEMENT OF SECTION

*Section*

## PART I—ADJUDICATION AREAS AND RECORDS

1. Power to prescribe adjudication areas, etc. and effect of order.
2. Appointment and powers of officers engaged in adjudication.
3. Subdivision of adjudication areas and notice.
4. Claims and attendance.
5. Stay of actions.
6. Lists of previously registered titles to be prepared.
7. Duties of demarcation officer.
8. Special powers of demarcation officer.
9. Duties and powers of registration officer.
10. Contents of adjudication record.
11. Principles of registration for adjudication record.
12. Procedure of ascertaining family representatives.
13. Notice of demarcation and registration.
14. Duties of adjudication officer.
15. Special powers of adjudication officer.
16. Evidence.
17. Adverse possession as basis of claim
18. Retention of documents.
19. Notice of completion of adjudication record.
20. Correction of errors.
21. Finality of registration.
22. Appeals.

## PART II—ORGANISATION AND ADMINISTRATION

*Land Registries and Officers*

23. Land registration district.
24. Land Registries.
25. Appointment of officers.
26. General powers of Registrar.
27. Seal of office.

*Land Registers*

28. The land register.
29. Notice of opening of land register to be given.
30. Manner of subsequent registration.
31. New editions of the land register.

*Maps Parcels and Boundaries*

32. Land Registry map.
33. Power of Registrar to require surveys and amend boundaries, etc.
34. Boundaries on Land Registry map not conclusive.
35. Maintenance of boundary marks.
36. Combinations and subdivisions.
37. Foreshore not included in title.
38. Alteration of contiguous parcels by subdivision, etc.

## PART III—EFFECT OF REGISTRATION

39. Interest to be conferred by registration.
40. Rights of proprietor.
41. Voluntary transfer.
42. Overriding interests.
43. Entries to give actual notice.

## PART IV—CERTIFICATES AND SEARCHES

44. Land certificate may be issued.
45. Land certificate to be produced with dealings.
46. Lost or destroyed land certificates.
47. Searches and copies.
48. Registration as evidence of signatures, etc.

## PART V—DISPOSITIONS

*General*

49. Subsequent dealings.
50. Protection of person dealing in registered land.
51. Additional fee for delayed registration.
52. Power to compel registration.
53. Priority of registered interests.

## ARRANGEMENT OF Sections—continued

*Section*

- 54. Saving for other laws.
- 55. Stay of registration.
- 56. Merger of registered interests.
- 57. Dispositions by family representatives.

*Leases*

- 58. Term of leases.
- 59. Periodic tenancies.
- 60. Registration of leases.
- 61. Lease of charged land.
- 62. Reversionary leases.
- 63. Holding over.
- 64. Agreements implied in leases on the part of the lessor.
- 65. Agreements implied in leases on the part of the lessee.
- 66. Meaning of "in repair".
- 67. Forfeiture of lease.
- 68. Notice before forfeiture.
- 69. Relief against forfeiture.
- 70. Variation and extension of leases.
- 71. Substitution of leases.
- 72. Subleases.
- 73. Surrender of leases.
- 74. Determination of leases.

*Charges*

- 75. Form and effect of charges.
- 76. Second or subsequent charges.
- 77. Charges by companies.
- 78. Agreements implied in charges.
- 79. Variation of charges.
- 80. Right of redemption.
- 81. Notice in case of default.
- 82. Power of sale under a charge.
- 83. Application of purchase money.
- 84. Appointment and duties, etc., of receiver.
- 85. Foreclosure.
- 86. No right of entry into possession on default.
- 87. Discharge of charge.
- 88. Satisfaction of charge.
- 89. Tacking and further advances.
- 90. Consolidation.
- 91. No lien by deposit only of land certificate.

*Transfers*

- 92. Mode of transfer.

- 93. Transfer of part.
- 94. Implied covenants, etc., on transfer of lease.
- 95. Restriction on transfer, etc., of lease if consent required.
- 96. Implied covenants, etc., on transfer of charged land.

*Easements, Restrictive Covenants and Profits a Prendre*

- 97. Grants of easements.
- 98. Restrictive covenants.
- 99. Profits a prendre.
- 100. Release, etc., or easements, restrictive covenants and profits.

*Proprietorship and Partition*

- 101. Registration and proprietorship.
- 102. Joint proprietors and severance of interest.
- 103. Proprietorship in common.
- 104. Partition.
- 105. Power for Registrar to order sale.
- 106. Procedure where share is small.

*Testamentary dispositions, etc.*

- 107. Testamentary dispositions, etc., not affected.

## PART VI—INSTRUMENTS AND AGENTS

- 108. Form of instruments.
- 109. Execution of instruments.
- 110. Proof of execution.
- 111. Instruments to be stamped.
- 112. Disposal of instruments.
- 113. Minors and registered land.
- 114. Agents for persons under disability.
- 115. Powers of attorney.

## PART VII—TRANSMISSIONS, TRUSTS AND FAMILY REPRESENTATION

- 116. Transmission on death.
- 117. Registration by personal representatives not on land register.
- 118. Applications for registration on death of proprietor, etc.
- 119. Effect of transmission by death.
- 120. Effect of transmission on bankruptcy.
- 121. Effect of notice of liquidation.
- 122. Registration of transmission by expropriation, etc.
- 123. Trust not to be entered in land register.

## ARRANGEMENT OF SECTIONS—continued

## Section

124. Trustees with no survivorship.  
 125. Appointment of family representatives.  
 126. Removal and replacement of family representatives.  
 127. Effect of registration of family representatives.

## PART VIII—JUDGMENTS AND WRITS OF EXECUTION

128. Power to register judgments, etc.  
 129. Effect of registration of judgment, etc.  
 130. Cancellation of registration of judgment, etc.  
 131. Sale in execution.

## PART IX—CAVEATS ETC.

132. Caveats generally.  
 133. Other prohibitions on registration.

## PART X—ADVERSE POSSESSION AND PRESCRIPTION

134. Acquisition of land by adverse possession.  
 135. Principles of possession.  
 136. Acquisition of easements, etc., by prescription.  
 137. This Part not to apply to registered land.

## PART XI—REGISTERED LAND ASSURANCE FUND AND RECTIFICATION OF LAND REGISTER

138. Assurance Fund.  
 139. Payment to Assurance Fund on first registration.  
 140. Rectification by Registrar.  
 141. Rectification by court.  
 142. Right to indemnity.

143. Costs, etc., on any claim.

144. Restriction on claims in respect of surveys.

145. Amount of indemnity.

146. Power to enforce covenants where indemnity paid.

## PART XII—DECISIONS OF REGISTRAR AND APPEALS

147. Power for Registrar to state a case.  
 148. Appeals against decision of Registrar.  
 149. Effect of notice of appeal on dispositions.  
 150. Power to make rules of court.

## PART XIII—MISCELLANEOUS AND TRANSITIONAL

151. Certification of documents.  
 152. Registration fees.  
 153. Addresses of caveators and others to be given to Registrar.  
 154. Service of notices.  
 155. Hearings and opportunity of being heard.  
 156. Indemnity of officers.  
 157. Offences.  
 158. Additional powers of Registrar.  
 159. Recovery of unpaid fees etc.  
 160. Enforcement of Registrar's orders for payment.  
 161. Regulations.  
 162. Registration of instruments in special cases.  
 163. Restricted application of other Acts.  
 164. Interpretation.  
 165. Short title, application and commencement.

## SCHEDULE—Enactments affected



## 1964, No. III

AN ACT TO PROVIDE FOR THE MORE EFFECTIVE REGISTRATION OF LAND AND TITLES AND FOR MATTERS CONNECTED THEREWITH.

[Section 16(52)]

Commence-  
ment.

BE IT ENACTED by the Legislature of the Federation of Nigeria in this present Parliament assembled and by the authority of the same as follows :—

## PART I.—ADJUDICATION AREAS AND RECORDS

1.—(1) If it appears to the Minister to be expedient to provide for the adjudication of interests in land or rights in land in the Federal territory and for the registration of titles thereto, the Minister may by order declare the whole or any part of the Federal territory to be an adjudication area for the purposes of this Act ; and upon publication of the order in the Gazette, this Act shall apply to the adjudication area so declared and have effect accordingly.

Power to  
prescribe  
adjudication  
areas, etc.  
and effect  
of order.

(2) An order under this section shall define the situation and limits of the adjudication area to which it relates either by means of a plan or by description ; and shall provide that the demarcation of parcels and presentation of claims to interests in land or rights in land within the adjudication area may begin at any time after a period to be prescribed.

(3) Where by reason of an order made under this section this Act is to apply and lists of titles are prepared for the purposes of an adjudication, no instrument or other document whatsoever shall be registered under the Land Registration Act or the Registration of Titles Act as the case may be, before the compilation of the land register for the appropriate section of the adjudication area, without the consent in writing of a registration officer.

Cap. 99,  
Cap. 181

(4) In this section, “interests in land” includes encumbrances.

2.—(1) There shall be appointed a fit person to be an adjudication officer for the purposes of this Act who shall be an officer of the High Court and shall have power to inquire into and adjudicate upon claims to land and interests in land within the adjudication area for which he was appointed or, subject to the terms of his appointment, for any adjudication area.

Appointment  
and powers  
of officers  
engaged in  
adjudication.

(2) An adjudication officer shall in respect of claims to land within an adjudication area have all the powers of a judge of the High Court, and shall exercise general control over all adjudications.

(3) There shall also be appointed for the purposes of demarcation of and registration of title to land subject to this Act, fit persons as demarcation officers and registration officers, who shall have the powers conferred upon such officers by this Part of this Act.

(4) Any demarcation officer may at all reasonable times enter upon land within an adjudication area for the purpose of demarcating or surveying land within such area ; and for such purpose may require persons likely in his opinion to have the knowledge, to give information regarding the boundaries of any such land.

(5) Any registration officer for the purposes of an inquiry under this Part of this Act may administer oaths and issue summonses, notices, or orders requiring the attendance of persons or the production of documents which he may consider necessary for any adjudication of claims under this Part of this Act.

(6) An adjudication officer may if he thinks fit exercise all or any of the powers and duties conferred upon demarcation officers and registration officers by this Part of this Act.

Subdivision  
of adjudica-  
tion areas  
and notice.

3.—(1) The adjudication officer may subdivide an adjudication area into adjudication sections and, where any such subdivision is made, separate notices in respect of each adjudication section shall be published by the adjudication officer in such manner as he thinks fit.

(2) A notice for publication under this section shall—

(a) fix a time within which persons claiming to be interested in land within the adjudication section are to present their claims ; and

(b) require any person making a claim to land the boundaries of which are not defined with reasonable accuracy, to point out to a demarcation officer the boundaries or boundary marks of the land affected ;

and as the case may require, the notice shall—

(c) specify as nearly as possible the situation and limits of the adjudication section ;

(d) state that rights to and interests in land within the adjudication section will be ascertained in accordance with the provisions of this Part of this Act and where so ascertained shall be registered under this Act ;

(e) state that rights to and interests in land within the boundaries of the adjudication section which are registered under the Registration of Titles Act will be brought on to the land register under this Act without requiring any formal application by persons interested ;

(f) confirm that if the name of a person appears in the list of owners prepared by the registration officer under this Part of this Act in respect of land in the adjudication section affected by the Land Registration Act as unregistered land and published as a schedule to the notice, the claim will be investigated by the registration officer, without the necessity for any claim by any such person.

Cap 181.

Cap. 99.

Claims and  
attendance.

4.—(1) Persons other than those named in the schedule to a notice published under section three of this Act claiming unregistered rights or interests in land within an adjudication section shall present their claims within the time limited by the notice.

(2) Any person required by an officer under this Part of this Act to attend for purposes of or incidental to an adjudication, may appear or be represented by a duly authorised agent at the time and place required by such officer ; and the person appearing or so represented shall produce to, and in proper case be given, an official receipt by the adjudication officer for any document or paper affecting or relating to his claim to land within the adjudication section.

(3) The demarcation, registration or adjudication of land within an adjudication section may proceed or, if begun may continue, notwithstanding the failure by any person to attend when required under this section.

(4) If an officer is satisfied in respect of any unregistered land in an adjudication section that claims are outstanding he may, if he thinks fit, require the attendance of any person appearing to be entitled, and deal with such land as if a claim had been duly made by or on behalf of any such person.

(5) Where a deceased claimant or owner is represented by one or more heirs or, in the case of separate group interests, by one or more of a group of heirs, in respect of a claim to land or an interest therein in any adjudication section, the appearance of such heirs or groups as the case may be in person or by duly authorised agents shall, unless the adjudication officer otherwise directs, be deemed to be an appearance by all the heirs or groups.

(6) Any instrument which may be void or voidable under any other Act by reason only of the fact that it has not been registered or presented for registration within the time prescribed under any other Act, shall be deemed to create an equitable interest affecting land; and a claim may be made in respect thereof and shall have effect, and may be dealt with accordingly on any adjudication.

5.—(1) Subject to the provisions of this section, an action concerning land or rights therein in any adjudication section shall not be commenced in any court without the consent in writing of the adjudication officer.

Stay of actions.

(2) Where an action is commenced in any court before notice is given of intention to adjudicate upon claims under this Part of this Act the action shall, if it is one for the recovery of premises, be completed before the adjudication; but otherwise the action shall, subject to any direction of the court, be transferred to and be determined by the adjudication officer sitting as a court. If any action is so transferred, the fee payable in respect of the hearing before the adjudication officer shall be the fee which would have been payable to the High Court if the case had not been so transferred; and the fee shall be paid and credited accordingly.

6. Where an order is made declaring an adjudication area, the registrar of titles appointed under the Registration of Titles Act shall prepare a list of the titles registered under that Act and relating to land in the adjudication area, and shall provide the adjudication officer with such other information as the adjudication officer may from time to time require in respect of any such registered title.

List of previously registered titles to be prepared. Cap. 181.

7. Subject to any directions which may from time to time be given by the adjudication officer, it shall be the duty of a demarcation officer—

Duties of demarcation officer.

(a) to see that the boundaries of each separate parcel of privately owned land and of public roads, rights of way and water, and of graveyards, (if not already demarcated by a physical feature), are properly demarcated or indicated;

(b) to submit to the adjudication officer, boundary disputes which the demarcation officer is unable to resolve;

(c) to demarcate the boundaries of all waste or unoccupied land;

(d) to prepare in respect of every adjudication section a plan (in this Act referred to as a "demarcation plan") showing thereon every parcel of land however owned, and marked so as to identify the parcels by means of a distinguishing number for each parcel;

(c) to show on the demarcation plan by means of a distinct colour or otherwise howsoever every parcel, the title to which is registered under the Registration of Titles Act.

Cap 181.

Special powers of demarcation officer.

8.—(1) In the performance of his duties, a demarcation officer may—

(a) if the boundary between separate parcels of land is curved or irregular or, in his opinion, if the boundary is otherwise inconvenient for the use of the land, re-align the boundary, and where necessary adjust the rights of the owners of the land affected by the exchange of land or by the payment of money ;

(b) demarcate any right of way necessary to give access to a public road in favour of any parcel of land completely surrounded by other parcels ;

(c) with the agreement of the owner or owners, group together in one or more parcels, separate areas of land owned by such owner or owners, if such grouping does not adversely affect the parcel of other persons.

(2) Where a boundary is re-aligned under this section the adjudication officer shall satisfy himself that the compensation is adequate, and in any proper case shall certify it as one in respect of which the person affected may appeal to the High Court.

Duties and powers of registration officer.  
Cap. 99.

9.—(1) A registration officer shall, when appointed, examine with all convenient speed such of the records or instruments kept in the land registry under the Land Registration Act as he considers relevant to land in the adjudication area, or section thereof, as the case may be.

(2) If after such examination the registration officer is satisfied that any person has a claim to or any right or interest in unregistered land within an adjudication section, he may, in his discretion prepare for publication with the notice under section three of this Act a list of owners showing the names of all persons so far as are known to him, the parcels of land concerned, and the nature of the rights or interests to which any claims relate.

(3) After the time limited by the notice referred to in subsection (2) of this section has expired, the registration officer shall consider all claims presented in accordance with the notice or the schedule thereto and, after such investigation as he considers necessary, the registration officer shall prepare a record (in this Act referred to as "the adjudication record") in such form as the adjudication officer may approve in respect of every parcel of land shown on the demarcation plan which is not registered under the Registration of Titles Act.

Cap. 181.

(4) If there are two or more claimants to any land or right in land within an adjudication section and the registration officer is unable to effect agreement between them he shall submit the case with particulars of the claim for hearing by the adjudication officer.

(5) The registration officer shall make any registration or re-registration and shall rectify the adjudication record in accordance with any order of the adjudication officer under this Act.

(6) The registration officer in the performance of his duties under this Act shall be subject to any general or special directions of the adjudication officer.

10.—(1) An adjudication record shall consist of forms each of which shall relate to a parcel of land within the adjudication section and contain the following particulars that is to say—

Contents of  
adjudication  
record.

(a) the number of the parcel of land as shown on the demarcation plan and its approximate area ;

(b) the name and description of the owner and the limitation (other than disability) on his power of dealing with the land ;

(c) if any owner or other person is under a disability, by reason of age, unsoundness of mind or otherwise howsoever the name of his guardian ;

(d) details of any lease, right of occupation, charge or other encumbrance or interest whatsoever amounting to less than ownership affecting the land, whether by virtue of customary law or otherwise, together with the name and description of every person entitled to the benefit thereof and particulars of any restriction on his power of dealing with it ;

(e) the fact that in any particular case the land is state land ; and

(f) the date on which the form is completed.

(2) Every form shall be signed by the registration officer and by the owner of the land or of any lease or charge or by the duly authorised agent of such owner, unless the adjudication officer in his discretion dispenses with the signature of the owner or his agent.

11.—(1) If the registration officer is satisfied when preparing an adjudication record—

Principles of  
registration  
for adjudica-  
tion record.

(a) that the right or interest of any person in land is such as would entitle him to be registered under this Act as the proprietor of that land, the registration officer shall enter the name of that person accordingly : Provided that the exercise by any person of rights in or over one or more parcels of land shall not be construed as conferring upon such person rights of ownership in or over any greater extent of land than that in or over which the rights are exercised ;

(b) that no person is entitled to exercise rights of ownership over defined land or that the rights enjoyed by any person thereover would be insufficient to entitle such person to be registered under this Act as the proprietor of that land, the registration officer shall record the land as state land ;

(c) that the right or interest of any person in or over land which is privately owned or in or over state land would be insufficient to entitle such a person to be registered under this Act as the proprietor of that land, but would entitle any such person to the benefit of any other registrable interest, the registration officer shall record such right accordingly with a note of the limits within which the right may be exercised, the extent to which the benefit thereof may be dealt with, and such other particulars as may be necessary to define the nature, incidence and extent of the right.

(2) The registration officer shall, if land is owned by two or more persons, ascertain whether they hold as joint tenants or as tenants in common and, if as tenants in common and the shares are not equal, the share of each such owner.

(3) If the land is family land, the registration officer shall, subject to the next succeeding section of this Act,—

(a) register the names of all members of the family who are entitled to a share therein together with the size of the share of each such member ; or

(b) if the number of members of a family exceeds twenty or the majority of such members so requests, register the name of the family and the names of representatives of the family who jointly are to have the exclusive rights and powers and be the registered proprietors for the purpose of any dealing with the land or any part thereof or interest therein subject to this Act and to such restriction as, in any particular case, the registration officer may deem it necessary to impose.

Procedure  
for  
ascertaining  
family repre-  
sentatives.

12.—(1) Where in the case of family land not more than twenty names are submitted to the registration officer as the names of persons to represent a family, and no objection thereto is offered by any member of the family, the registration officer shall enter such names in the adjudication record as the family representatives.

(2) Where in the case of family land no names or more than twenty names are submitted, or where there is an objection to a member of the family, the registration officer shall refer the case to the adjudication officer for his opinion ; and after considering any custom prevailing within the family and the opinion of the adjudication officer, the registration officer shall appoint not more than twenty persons as family representatives.

(3) Where land is owned by a family and the adjudication officer is not satisfied that any custom exists in relation to the family land, the adjudication officer shall direct the holding of a family meeting not later than twenty-one days after delivery of the direction to the head of the family or his representative, requiring the family to elect not more than twenty persons to be the family representatives. The head of the family or his representatives shall cause all adult members of the family, so far as possible, to be notified accordingly, and when held, all adult members present at the family meeting shall be entitled to vote ; but the fact that any member of the family fails to receive notice of or to attend such meeting shall not invalidate the meeting. If the number of names of the persons elected as family representatives at the family meeting is not more than twenty, notice thereof with a list of the names with sufficient other information which the adjudication officer may reasonably require shall be forwarded by the head of the family or his representative to the adjudication officer not later than seven days after the meeting ; and if he is satisfied that the family meeting was properly held, the adjudication officer shall enter those names as the family representatives in the adjudication record.

(4) If no agreement is reached, the adjudication officer shall record the land as family land ; and when so recorded it shall have the effect of a caveat under this Act and no dealing with the land may be registered until such time as the family representatives are ascertained.

Notice of  
demarcation  
and registra-  
tion.

13. At least six clear days before demarcation is to begin, the demarcation officer shall, as directed by the adjudication officer, give notice of the intended time and place of the demarcation and of registration thereafter to persons likely to be affected thereby.

**14.—(1)** The adjudication officer shall supervise every adjudication, and shall hear and decide—

(a) any dispute as to ownership or as to boundaries of land within the adjudication are or as to any lease, charge or other encumbrance whatsoever affecting such land if the demarcation officer or the registration officer as the case may be has been unable to resolve the dispute ;

(b) any petition—

(i) in respect of an act or decision of a demarcation officer, or

(ii) to rectify an original entry in the adjudication record prepared by a registration officer under the provisions of section nine of this Act.

(2) The adjudication officer shall on the hearing of a dispute or petition under this section record the proceedings in such form as he thinks necessary ; and the procedure on the hearing of a civil suit shall, as far as practicable be followed and the fees prescribed for any such hearing shall be the fees payable.

**15.** In the course of an adjudication, the adjudication officer may—

(a) give such instructions as he thinks necessary to implement the provisions of this Part of this Act relating to the procedure to be followed when demarcating or registering land within an adjudication area ;

(b) direct the owner of land to enclose it by means of a boundary wall, fence or hedge or prescribe the demarcation of the boundaries in some other permanent manner ;

(c) where persons, whether or not heirs of a deceased owner, jointly claim land as co-owners, order a partition of the land amongst such persons in accordance with an agreement approved by the adjudication officer or, if there is no agreement, as the adjudication officer may direct ;

and any person concerned or affected shall comply with the terms of any instruction, direction, or order, as the case may be, given or made by the adjudication officer.

**16.—(1)** The adjudication officer may act on any testimony sworn or unsworn, and may receive as evidence any statement, document information or matter which in his opinion may assist him to deal effectively with the matters before him, whether the same would, apart from this section, be legally admissible evidence or not.

(2) Subject to the foregoing provisions of this section, the Evidence Act shall apply to all proceedings before an adjudication officer in the same manner as if he were a court within the meaning of that Act.

**17.** It is hereby declared that a claim under this Part of this Act based on acquisition by adverse possession or prescription may be made ; and if it is accepted by the adjudication officer, it shall be registered in like manner as if it were an ordinary claim under this Act.

**18.** The adjudication officer and the registration officer as the case may require shall retain all documents of title produced in respect of any claim :

Duties of the  
adjudication  
officer.

Special  
powers of  
adjudication  
officer.

Evidence.

Cap. 62.

Adverse  
possession  
as basis of  
claim.

Retention of  
documents.

Provided that if any document of title produced to any such officer includes unregistered land not comprised in the claim, it shall be not retained; and the adjudication officer after endorsing thereon a note of the claim shall return the document to the person producing it.

Notice of completion of adjudication record.

19. Where the adjudication record in respect of any adjudication section has been completed, the adjudication officer shall sign and date a certificate to that effect, and unless a petition on appeal is filed, shall forthwith thereafter give notice of the completion of such adjudication record and of the place at which it may be inspected during office hours.

Correction of errors.

20. The adjudication officer of his own motion may at any time correct clerical errors or errors of a minor nature in the adjudication record.

Finality of registration.

21. Subject to any appeal under this Part of this Act, registration as entered in the adjudication record shall, after the expiration of thirty days from the date of the certificate of the adjudication officer, be final; and the Registrar of Land under this Act shall thereafter compile editions of the land register from such record.

Appeals.

22.—(1) Any person aggrieved by any act or decision of a demarcation officer or by any entry in the adjudication record made by the registration officer may at any time before notice of the completion of the adjudication record has been given, petition the adjudication officer in respect of any such act, decision or entry; and the provisions of section fourteen of this Act shall have effect, and the petition may be dealt with accordingly.

(2) Any person aggrieved by any act or decision of the adjudication officer may appeal to the High Court within thirty days from the date of the certificate given on completion of the adjudication record in respect of the adjudication section concerned, or within such extended time as the High Court, if it thinks necessary in the interest of justice, may allow.

## PART II.—ORGANIZATION AND ADMINISTRATION

### *Land Registries and Officers*

Land registration districts.

23.—(1) The Minister may at any time by order in the Gazette constitute the Federal territory or any adjudication area therein a land registration district; and upon the making of the order, all land affected by a final adjudication record as well as land duly registered under the Registration of Titles Act shall be included in the appropriate land registration district and may be registered accordingly under this Act.

Cap. 181.

(2) Until the Minister constitutes a land registration district under subsection (1) of this section, the land registration district which, immediately before the coming into operation of this Act was in existence in the Federal territory, shall be deemed to be the land registration district for the purposes of this section.

(3) The boundaries of any land registration district may at any time by order of the Minister be amended for the purpose of constituting any new land registration district or of adjustment of boundaries of any existing land registration district.

24. There shall be maintained in every land registration district a Land Registry which shall form part of the High Court and in which there shall be kept in accordance with the provisions of this Act—

Land  
Registries.

- (a) a register of land to be known as the land register ;
- (b) a map to be known as the Land Registry map ;
- (c) parcel files containing the instruments, which support subsisting entries in the land register, and any filed plans and documents ;
- (d) a book in the prescribed form to be known as the presentation book in which shall be recorded all applications numbered consecutively in the order in which they are presented to the land registry ;
- (e) a record to be known as the mutation record ;
- (f) an index to be known as the Nominal Index in which shall be kept in alphabetical order a record of the names of the proprietors (other than banks, building societies and such corporations as the Registrar may from time to time direct) of land, leases and charges of any description with such information as to the parcels affected and necessary to identify ;
- (g) a power of attorney index.

25.—(1) There shall be appointed as a member of the Public Service of the Federation a fit person to be Registrar of Land and such person shall, under the general direction of the Chief Justice of Lagos have the control of and administer all Land Registries under this Act.

Appointment  
of officers.

(2) There shall also be appointed as members of such public service a deputy registrar of land and in respect of every Land Registry such assistant registrars and other officers or employees as may be necessary for carrying out the provisions of this Act.

(3) The deputy registrar shall have all the powers of the Registrar under this Act ; but unless for any reason the Registrar is unable to exercise the power, a deputy registrar shall not have the power of delegation conferred by the next succeeding subsection.

(4) The Registrar may by instrument under his hand delegate to any assistant registrar any of the powers of the Registrar under this Act other than the power to delegate, and may at any time likewise revoke or vary any such delegation ; but the fact that the Registrar has delegated any power under this subsection shall not preclude the Registrar from himself exercising the power.

(5) The person holding office at the commencement of this Act as registrar of titles shall be deemed to have been appointed Registrar of Land under subsection (1) of this section ; and all other persons who at the commencement aforesaid are officers or employees of the land registry established under the Registration of Titles Act shall, unless the Public Service Commission otherwise directs in respect of a particular office or employment, be deemed to have been appointed to the like offices or positions under this Act.

Cap. 181.

26. The Registrar, and every assistant registrar to the extent to which any powers are delegated to him shall have and may exercise the following powers additional to any other powers conferred by this Act, that is to say—

General  
powers of  
Registrar.

(a) he may in respect of any particular parcel of land or encumbrance require the proprietor or any person to produce any instrument, certificate or other document or plan relating to the land, or encumbrance and the proprietor or other person as the case may be, shall produce the same ;

(b) he may summon a proprietor or other person interested to appear and give information respecting any land, encumbrance or other instrument, certificate, document, or plan relating to the land of the proprietor or encumbrance affecting the land, and the proprietor or other person as the case may require, shall appear and give the information ;

(c) he may refuse to register any deed or document presented to him if any instrument, certificate or other document or plan or information required by him to be produced or given is withheld or anything required by him to be done under this Act is not so done.

(d) he may administer oaths or affirmations and may require that any proceedings, information or explanation affecting registration to be verified on oath or affirmation ;

(e) he may order that the costs, charges and expenses incurred by him or by any other person in connection with any investigation or hearing held by him for the purposes of registration under this Act shall be borne and paid by such persons and in such proportions as he may think fit.

(2) Where the Registrar or any assistant registrar under this section is empowered to administer oaths or affirmations any such officer may take a statutory declaration under the Oaths Act 1963 in substitution therefor, and in any case where an oath or affirmation is administered or declaration is taken no oath fee or stamp duty as the case may be, shall be payable or be paid.

1963 No. 23.

Seal of office.

27. There shall be a seal of the Land Registry showing the Coat of Arms and such reference on the surround to the Land Registry as the Chief Justice of Lagos may approve in writing. Every instrument bearing the imprint of such seal shall be received in evidence by all courts and persons ; and, unless the contrary is shown, it shall be deemed, without further proof, to have been duly sealed and issued by or under the direction of the Registrar.

### Land Registers

The land register.

28.—(1) The Registrar may divide a registration district into registration sections and open land registers for every such section ; and accordingly all land dealt with at the time of an adjudication in respect of a registration section which is included therein (whether or not also included in the adjudication record) shall be entered in the land register, and a parcel of land and every lease thereof shall together comprise editions of that part of the land register which relates thereto.

(2) The Registrar shall compile the land register in the following manner, that is to say—

(a) for every parcel of land or as the case may be any lease thereof registered under the Registration of Titles Act there shall be prepared editions showing all subsisting interests registered under that Act ;

Cap. 181.

(b) for every parcel of land included in an adjudication record under the provisions of Part I of this Act and not registered under the Registration of Titles Act—

(i) every person entitled in the adjudication record to ownership shall be registered as proprietor of the parcel recorded in his name therein subject to any limitation, restriction, or encumbrance affecting the parcel of land ;

(ii) where no owner has been found, the parcel shall be registered as state land subject to any rights or interests in respect of it shown in the adjudication record ;

(iii) in any other case, the person named in the adjudication record as entitled to the benefit of any rights or interests in any parcel shall, subject to any overriding interest under this Act affecting the right or interest, be registered accordingly.

(3) If the boundaries of a parcel of land are fixed otherwise than by a survey approved by the Federal Director of Surveys, the Registrar may in his discretion endorse and sign on the appropriate land register a note that it is issued limited as to parcels ; and where the register is so noted, the provisions of this Act as to rectification of boundaries shall have effect accordingly.

29.—(1) The Registrar shall as soon as may be after the opening of an edition of the land register under section twenty-eight of this Act, give notice in writing of the fact to all persons having registered interests in any land or lease included therein.

Notice of opening of land register to be given.

(2) On receipt of a notice under this section the owner of a title formerly registered under the Registration of Titles Act shall surrender his certificate of title to the Registrar and, if entitled, shall receive a land certificate under this Act in substitution for such certificate of title.

Cap. 181.

30. Registration of any instrument under this Act (other than of an instrument as the basis of title in respect of the bringing of land under this Act) shall on payment of the prescribed fees be effected by an entry in the appropriate edition of the land register made in such form as the Registrar may from time to time direct.

Manner of subsequent registration.

31. If the number or the nature of the entries so require or the Registrar thinks fit, the Registrar may at any time open a new edition of a land register in substitution for the existing edition. The substituted edition shall show subsisting entries ; and all other entries that have been determined or have ceased to have any effect shall be omitted.

New editions of the land register.

### *Maps, Parcels and Boundaries*

32.—(1) There shall be compiled from the demarcation plans a map to be called the Land Registry map showing the boundaries of each parcel of registered land and such other information as the Registrar may direct or require ; and such map shall be drawn to a scale and comprise as many sheets as the Registrar thinks necessary.

Land Registry map.

(2) Where the Registrar divides a registration district into registration sections, he shall cause the division to be shown on the Land Registry map and identify the sections by distinctive names. Any registration section may be further divided by the Registrar into areas to be known as blocks, which shall be shown on the said map and be given distinctive numbers or letters, or a combination of numbers and letters, as the case may require.

(3) The Registrar may, at any time, combine or divide registration sections or blocks, or vary their boundaries.

(4) The parcels of land in each registration section or block shall be numbered consecutively and the name of the registration section and the number and letter of the block (if any) and the number of the parcel shall together be a sufficient reference to any parcel.

(5) A plan may at any time be filed in respect of any parcel to augment the information available from the Land Registry map; and the filing of such plan shall be noted where directed by the Registrar.

Power of Registrar to require surveys and amend boundaries, etc.

33.—(1) The Registrar may require a survey of any land to be made for the purposes of this Act and, subject to the provisions of this section, may with the agreement in writing of any person liable to be affected thereby, alter or replace the Land Registry map or any part thereof as a result of such survey.

(2) There shall be a form to be known as a mutation form, and no alteration of any boundary shown on the Land Registry map shall be made except as directed by the Registrar by means of a mutation form, which shall thereafter be filed in the Land Registry.

(3) Where the boundary of a parcel is altered, its parcel number shall be cancelled and it shall be given a new number.

(4) The Registrar may, at any time, direct the preparation of a new edition of the Land Registry map or any part thereof; and matter which the Registrar considers obsolete, may be omitted from any such new edition.

Boundaries on Land Registry map not conclusive.

34.—(1) The Land Registry map shall not be final and conclusive evidence as to the precise position of any boundary; and where any uncertainty or dispute arises as to the position of a boundary the Registrar, on the application of any interested party, shall give all persons appearing by the land register to be affected an opportunity of being heard; and on such evidence as he considers relevant, the Registrar shall ascertain and fix the position of the uncertain or disputed boundary by survey or by description as the case may require.

(2) Where the Registrar exercises his power under subsection (1) of this section, he shall make a note to that effect on the Land Registry map and in the appropriate editions of the land register and shall file such plan or description as may be necessary to record his decision.

(3) No court shall entertain any action or other proceeding relating to a dispute as to the boundaries of registered land unless the dispute has been dealt with in the first instance by the Registrar under this section.

Maintenance of boundary marks.

35.—(1) The Registrar may at any time by order in writing direct which of adjoining proprietors shall be responsible for the care and maintenance of a boundary mark; and when so directed, the proprietor designated shall maintain in good order the boundary marks on his land.

(2) Any proprietor responsible for the maintenance of boundary marks who allows a boundary mark to fall into disrepair or be destroyed or removed shall be guilty of an offence and liable on conviction to a fine of ten pounds.

(3) Any person who defaces, removes, injures or otherwise impairs any boundary mark unless authorised to do so by the Registrar in writing, shall be guilty of an offence and liable on conviction to a fine of twenty pounds or to imprisonment for a term of three months, or to both.

(4) Any person convicted of an offence under this section shall, whether or not any penalty therefor is imposed upon him, be liable to pay the cost of restoring such boundary marks; and the cost of the restoration may in proper case be recovered as a civil debt by any person responsible under this section for the maintenance of boundary marks on the land affected.

(5) For the purposes of this section, "boundary mark" includes any fence, hedge, stone, pillar, (whether survey pillar, peg, pin or tube) or wall or other mark whatsoever which serves to demarcate the boundary of land.

36. Subject to the provisions of this Act, where—

(a) contiguous parcels of registered land are owned by the same proprietor and are subject in all respects to the same rights and obligations, the Registrar on the application of such proprietor, may combine the parcels by closing the editions relating thereto and opening new editions in respect of the parcels resulting from such combination;

(b) the proprietor of unencumbered land applies for the division of it into two or more parcels and the Registrar is satisfied that the land is free from incumbrances and is suitable for such division, the Registrar shall give effect to the application by means of a mutation record and by the closing of any relevant edition and the opening of new editions in the land register.

37. It is declared that land below high water mark at ordinary spring tides shall in the case of any seaward or tidal river boundary be deemed to be excluded from any parcel of land in the land register unless the contrary is expressly noted in the relevant edition of the land register.

38.—(1) On the application of the proprietors of contiguous parcels of registered land who are desirous of subdividing or altering the boundaries thereof, the Registrar may if satisfied that all necessary consents in writing of other persons in whose names any right or interest in such parcels is registered and of any caveator have been given and are produced, and subject to the provisions of this section, give effect to the application by means of a mutation record and cancel the relevant editions relating to such parcels and prepare new editions in accordance with the scheme of subdivision or alteration of boundaries, as the case may require.

(2) If in the opinion of the Registrar any alteration of contiguous parcels under this section would involve substantial changes of ownership which should be effected by transfer under this Act without invoking the provisions of this section, he may, in his absolute discretion, refuse to give effect to the application.

(3) Where any boundary is subdivided or altered under this section, the new parcels shall, anything to the contrary in this Act notwithstanding, vest in the persons in whose names they are registered without further authority than this section.

Combina-  
tions and  
sub-  
divisions.

Foreshore  
not included  
in title.

Alteration of  
contiguous  
parcels by  
sub-  
division, etc.

## PART III.—EFFECT OF REGISTRATION

## 39.—(1) Subject to the provisions of this Act,—

Interest to  
be conferred  
by  
registration.

(a) the registration of any person as the proprietor of any land shall not confer any right to minerals or mineral oils thereon or thereunder, but otherwise it shall vest in the person so registered the absolute ownership of that land together with all rights and privileges belonging or appurtenant thereto ;

(b) the registration of any person as the proprietor of a lease shall vest in that person the leasehold interest described in the lease together with all rights express and implied and appurtenances attached thereto and subject to all agreements express or implied and all liabilities and incidents of a lease.

Cap. 120,  
121.

(2) For the purposes of this section “mineral oils” and “minerals” have the meaning set out in the Mineral Oils Act and the Minerals Act.

Rights of  
proprietor.

40.—(1) The rights of a proprietor, whether acquired on first registration or subsequently for valuable consideration or by an order of a High Court or any superior Court shall be rights not liable to be defeated except as provided in this Act ; and such rights shall be held by the proprietor, together with all privileges and appurtenances belonging thereto, free from all other interests and claims whatsoever, including those of the state, but subject—

(a) to any encumbrances and to the conditions and restrictions, if any, shown in the land register ;

(b) unless the contrary is expressed in the land register, to such liabilities, rights and interests as affect the same and are declared by this Act not to require notification on the land register.

(2) Nothing in this section shall be construed so as to relieve a proprietor from any duty or obligation to which he is subject as a trustee or family representative under this Act.

Voluntary  
transfer.

41. Every proprietor who by transfer acquires any land or charge without valuable consideration shall hold the land or charge, as the case may be, subject to all unregistered rights and interests affecting the same to which they were subject when in the hands of his transferor, and subject also to the provisions of any law relating to bankruptcy and to the winding up provisions of the Companies Act ; but otherwise any such transfer shall, when registered, have in all respects the same effect as a transfer for valuable consideration.

Cap. 37.

Overriding  
interests.

42.—(1) All registered land shall, unless the contrary is expressed in the relevant edition of the land register be subject to such of the following overriding interests as may for the time being subsist and affect the same that is to say—

(a) rights of way, rights of water and any easement or profit a prendre subsisting at the time of first registration under this Act ;

(b) rights of entry, search and user conferred by any other Act ;

(c) leases or agreements for leases for any term less than five years where there is actual occupation under the lease or agreement ;

(d) any tax or rate for the time being declared by law to be a charge on land or buildings erected thereon ;

(e) rights acquired or in process of being acquired by virtue of any enactment relating to the limitation of actions or by prescription; and

(f) the rights of every person in possession or actual occupation of the land to which he may be entitled in right of such possession or occupation, save where enquiry is made of such person and the rights are not disclosed.

(2) The Registrar may in proper case direct registration of any of the liabilities, rights and interests referred to in subsection (1) of this subsection in such manner as he thinks fit; and to the extent to which registration is so directed, this section shall cease to have effect.

43. Every proprietor shall be deemed to have had notice of every entry in the land register relating to any land, or encumbrance acquired by him.

Entries to give actual notice.

#### PART IV.—CERTIFICATES AND SEARCHES

44.—(1) The Registrar shall, if requested by the proprietor of any land, issue to him a land certificate in the prescribed form showing all subsisting entries affecting that land. A land certificate when issued shall be prima facie evidence of the particulars set out in the relevant edition of the land register at the date of issue of such certificate, but shall not obviate the necessity for a search of the land register. Not more than one land certificate shall be issued in respect of each parcel.

Land certificate may be issued.

(2) Where there are more proprietors than one, the proprietors shall agree among themselves as to who is to receive the land certificate and, if they are unable to agree, the land certificate shall be retained in the Land Registry.

(3) If a land certificate is issued under this section the date of its issue shall be noted in the relevant edition of the land register.

45.—(1) Where a land certificate has been prepared and is not retained in the Land Registry, it shall be produced to the Registrar on the registration of any dealing with the land to which it relates, unless the Registrar for sufficient cause dispenses with its production.

Land certificate to be produced with dealings.

(2) Upon completion of the registration a note of the dealing shall be made on the land certificate, and if the Registrar thinks fit, the land certificate may be destroyed or be retained in the Land Register.

46.—(1) If a land certificate is lost or destroyed the proprietor may apply to the Registrar for the issue of a new land certificate and shall produce evidence to satisfy the Registrar of the loss or destruction of the previous land certificate.

Lost or destroyed land certificates.

(2) The Registrar may require a statutory declaration under the Oaths Act 1963 that the certificate has been lost or destroyed; and if satisfied with the evidence as to the loss or destruction of the land certificate, and after publication in such manner as he may authorise of notice of intention to do so, the Registrar may issue a new land certificate.

1963 No. 23.

47.—(1) Any person may apply in writing to the Registrar for leave to inspect any edition of the land register and any sheet of the Land Registry map or any instrument or plan filed in the Land Registry, during the hours of business, and leave may be granted on such conditions as the Registrar thinks fit.

Searches and copies.

(2) Any person may require an official search in respect of any parcel and upon prepayment of the prescribed fee shall be entitled to particulars of the subsisting entries in the edition relating thereto or to obtain a certified copy of any edition or part of the Land Registry map or of any instrument or plan filed in the Land Registry.

Registration  
as evidence  
of signatures,  
etc.

48.—(1) Judicial notice shall be taken of the signature of the Registrar, the deputy registrar and every assistant registrar by all courts and persons.

(2) Every copy or extract certified by the Registrar shall in any proceedings be received as prima facie evidence of the original entry in the land register, or of the Land Registry map or of any instrument or plan filed in the Land Registry, and of the matter and transactions therein recorded or registered.

(3) Save with the leave of a court, no process for compelling the production of any part of the land register or of the Land Registry map or of any instrument or plan filed in the Land Registry shall issue, and leave shall not be granted where a certified copy or other secondary evidence will suffice; and if a court issues any such process, the process shall show on its face that it was issued with the leave of the court.

#### PART V.—DISPOSITIONS

##### *General*

Subsequent  
dealings.

49.—(1) No land, lease or charge shall be capable of being disposed of except in accordance with the provisions of this Act and every attempt to dispose of such land, lease or charge otherwise, shall be ineffectual to create, extinguish, transfer, vary or affect any estate, right or interest, legal or equitable, in the land, lease or charge.

(2) Nothing in this section shall be construed as preventing any unregistered instrument from operating as a contract.

Protection  
of person  
dealing in  
registered  
land.

50.—(1) No person dealing or proposing to deal for valuable consideration with a proprietor shall be required or be in any way concerned—

(a) to enquire or ascertain the circumstances in or the consideration for which such proprietor or any previous proprietor was registered; or

(b) to see to the application of any consideration or any part thereof; or

(c) to search any register kept under the Land Registration Act or the Registration of Titles Act.

Cap. 99.  
Cap. 181.

(2) Where the proprietor of land or of a lease or a charge is a trustee or a family representative he shall, for the purpose of any registered dealings, be deemed to be the absolute proprietor thereof and no disposition by such trustee or family representative to a bona fide purchaser for valuable consideration shall be defeasible by reason only of the fact that such disposition amounted to a breach of trust or breach of family law or custom.

51. If an instrument is presented for registration later than two months from the date of its execution an additional fee equal to the registration fee shall be payable for each two months which have elapsed since its execution ; but in no case shall the additional fee payable exceed an amount that is more than five times the original registration fee payable.

Additional  
fee for  
delayed  
registration

52.—(1) Where the Registrar is satisfied that any person, through his own wilful default, has failed to register an instrument, the Registrar may by notice in writing order such person to present the instrument for registration under this Act ; and the registration fee shall upon receipt of the notice become due and payable whether or not the instrument is presented for registration.

Power to  
compel  
registration.

(2) Any person who, within one month of the service upon him of a notice under this section fails to comply therewith shall be guilty of an offence and liable on conviction to a fine of twenty pounds.

53.—(1) Interests appearing in an edition of the land register shall have priority according to the order in which the instruments creating them were presented for registration, irrespective of the dates of the instruments ; and no person shall be concerned to see that registration is completed on the date of presentation of the relevant instrument.

Priority of  
registered  
interests.

(2) Instruments sent by post or under cover and received during the hours of business shall be deemed to be received simultaneously immediately before the closing of the office for that day ; and those received between the time of closing and the next opening of the office for business shall be deemed to be received simultaneously immediately after such next opening.

(3) Where more instruments or applications than one and affecting or relating to the same land, lease or charge are presented on the same day or at so short an interval from each other that in the opinion of the Registrar a question of priority for registration between them arises, the Registrar may refuse registration until he has heard and determined the rights of the parties interested thereunder.

54. Nothing in or purporting to be done under this Act shall affect the provisions of any written law requiring or prescribing the consent of any authority to any dealing with or disposition of any land, lease or charge, and accordingly registration under this Act shall not validate any dealing otherwise invalid by any such written law.

Saving for  
other laws.

55.—(1) Where any person proposing to deal with registered land has, with the consent in writing of the proprietor, applied for an official search and has stated in his application the particulars of the proposed dealing, the Registrar shall make an order staying registration of any instrument affecting the land to be comprised in the proposed dealing. An order so made shall stay registration for fourteen days from the time when application for the search was made, and the Registrar shall note the land register accordingly.

Stay of  
registration

(2) If within the said period of fourteen days a properly executed instrument effecting the proposed dealing is presented for registration, such instrument shall have priority over any other instrument presented for registration after the time of application for the search; and such instrument may be registered notwithstanding any caveat or any other entry made in the land register during the said period, and the stay of registration shall lapse.

(3) Subject to the presentation of the instrument duly executed in respect of which the stay of registration was obtained and within the prescribed period, any other instrument and any caveat or application received in the Land Registry during such period, may be dealt with in the same manner, and shall have the same priority and be as effectual as if no stay of registration had been obtained.

Merger of registered interests.

56.—(1) Where on the registration of any disposition interests under this section vest in the same proprietor, the interests shall not merge before a surrender or discharge is registered or, as the case may require, the parcels are combined in one title or the titles are endorsed by the Registrar.

(2) The interests under this section are any of the following, that is to say—

- (a) lessor and lessee;
- (b) chargor and chargee;
- (c) land burdened with an easement, profit a prendre or restrictive covenant, and land which benefits therefrom.

Dispositions by family representatives.

57. Where land is family land a disposition shall not be accepted if it is signed by a number of family representatives less than that appearing in the land register unless—

- (a) it is executed by all the surviving family representatives; and
- (b) it is supported by a statutory declaration under the Oaths Act 1963 made by the surviving family representatives to the effect that they have consulted all adult members of the family in accordance with family custom and that a majority of such adult members is in favour of the disposition.

1963 No. 23.

### Leases

Term of leases.

58.—(1) Subject to the provisions of this or any other Act, the proprietor of land may lease it upon such conditions as he thinks fit to any person for a fixed or determinable term, or for a term which in itself is indefinite but may be determined by the lessor or the lessee by notice under this Act, or by mutual agreement.

(2) For the avoidance of doubt, any room or part of a building erected on land may be the subject of a lease and any such disposition shall be registrable accordingly.

Periodic tenancies.

59.—(1) Where in any lease the term is not specified and no provision is made for the giving of notice to determine the tenancy, the lease shall be deemed to create a periodic tenancy.

(2) Where the proprietor of any land permits the exclusive occupation of the land or any part thereof by any other person at a rent but without any agreement in writing, that occupation shall be deemed to create a periodic tenancy.

(3) For the purposes of this section, the term of a periodic tenancy shall be computed by reference to the date on which rent is payable, but in no case exceeding six calendar months; and accordingly a periodic tenancy may be determined by either party giving to the other notice expiring on the next succeeding day on which rent would, but for the notice, be owing and payable, and by payment of all rent due up to the expiry date of the notice.

60. A lease for a period of five years or more, or which is for a term less than five years but contains an option whereby the lessee can require the lessor to grant him either a further term or further terms which, with the original term, would exceed five years, shall be in the prescribed form. The lease shall be presented for registration in triplicate against the land as an encumbrance, and registration shall be completed by the opening of an edition of the land register in respect of the lease in the name of the lessee and by thereafter retaining one copy of the instrument in the Land Registry.

Registration  
of leases.

61. When any land is subject to a charge, no lease of such land shall be registered without the previous consent in writing of the proprietor of the charge unless the charge otherwise expressly so provides.

Lease of  
charged  
land.

62.—(1) A lease may be made for a term to begin on a future date, not being later than twenty-one years from the date of the lease, but until registered, a lease for any such term shall be of no effect.

Reversionary  
Leases.

(2) Any instrument purporting to create a lease to begin on a date more than twenty-one years after the date of the instrument shall be void.

63.—(1) Where a person, having lawfully entered into occupation of any land as a lessee, continues to occupy that land with the consent of the lessor after the determination of the lease, the person who so entered shall, in the absence of any evidence to the contrary, be deemed to be a tenant holding the land on a periodic tenancy and, subject to this or any other Act, the conditions of the determined lease, so far as they are appropriate to a periodic tenancy under this Act, shall continue to apply.

Holding  
over.

(2) For the purposes of this section, the acceptance of rent in respect of any period after the determination of the lease shall, if the former tenant is still in occupation and subject to any agreement to the contrary, be deemed to constitute evidence of consent to the continued occupation of the land.

64. Save as otherwise expressly provided in the lease, there shall be implied in every lease, agreements by the lessor with the lessee binding the lessor—

Agreements  
implied in  
leases on the  
part of the  
lessor.

(a) that so long as the lessee pays the rent and observes and performs the agreements and conditions contained or implied in the lease and on his part to be observed and performed, the lessee shall and may peaceably and quietly possess and enjoy the land during the term of the lease without any lawful interruption from or by the lessor or any person rightfully claiming through or under him;

(b) that the lessor will not use or permit to be used any adjoining or adjacent land of which he is the proprietor or lessee in any way which would render the land leased unfit or materially less fit for the purpose for which it was leased;

(c) where any flat or room is leased furnished or unfurnished, that he will keep the roof and main walls in repair ;

(d) where any dwelling-house, flat or room is leased furnished, that such dwelling house, flat or room is fit for habitation at the commencement of the tenancy.

Agreements implied in leases on the part of the lessee.

65. Save as otherwise expressly provided in the lease, there shall be implied in every lease, agreements by the lessee with the lessor binding the lessee—

(a) to pay the rent reserved by the lease at the times therein mentioned ;

(b) during the continuance of the lease, to pay all rates and taxes which may be payable in respect of the land leased not otherwise exclusively payable by the lessor under any written law ;

(c) in the case of agricultural land, to farm the same in accordance with the practice of good husbandry and to yield up the land at the end of the term in good heart ;

(d) except where a dwelling-house is leased furnished or a flat or room is leased furnished or unfurnished, to keep all buildings comprised in the lease in repair ;

(e) to permit the lessor or his agent with or without workmen or others at all convenient times and after reasonable notice to enter on the land and examine the state and condition thereof ;

(f) to repair or otherwise make good any defect or breach of agreement of which notice shall be given, within such reasonable period as may be specified in the notice.

Meaning of "in repair".

66. Where an agreement is contained or implied in any lease to keep any building in repair, the building shall be kept in the same state of repair as that in which an owner might reasonably be expected to keep his property, due allowance being made for the age, character and locality of the building at the commencement of the lease :

Provided that there shall not be implied in any such agreement an undertaking to put any building into a better state of repair than that in which it was at the commencement of the lease.

Forfeiture of lease.

67. Subject to the provisions of this Act as to relief against forfeiture and to anything to the contrary in a lease, the lessor thereof shall have the right to forfeit the lease if the lessee commits a breach of any agreement or condition express or implied in the lease ; and the right of forfeiture may be exercised—

(a) by entry upon and remaining in possession of the land affected where neither the lessee nor any person claiming through or under him is in occupation of the land ; or

(b) by action in the High Court.

Notice before forfeiture.

68. Notwithstanding anything to the contrary contained in any lease, a lessor shall not be entitled to exercise the right of forfeiture for the breach of any express or implied agreement or condition in the lease, until the lessor has served on the lessee a notice—

(a) specifying the particular breach complained of ; and

(b) if the breach is capable of remedy, requiring the lessee to remedy the breach within such reasonable period as may be specified in the notice ; and

(c) in any case, requiring the lessee to make compensation in money for the breach, and the lessee fails within a reasonable time thereafter to remedy the breach, if it is capable of remedy and, as the case may be, to make reasonable compensation in money.

69.—(1) A lessee upon whom a notice has been served under section sixty-eight of this Act or against whom the lessor is proceeding by action or re-entry to enforce his right of forfeiture, may apply to the High Court for relief, and the High Court having regard to the proceedings and conduct of the parties and the circumstances of the case may, if it thinks fit, grant or refuse relief; and relief if granted shall be upon such terms as the High Court may impose.

Relief  
against  
forfeiture.

(2) The High Court may, on application by any person claiming any interest in the property comprised in the lease or any part thereof as sublessee or chargee, make an order vesting the property or any part thereof as the case may require in such sublessee or chargee for the whole of term of the lease or any less term, upon such conditions as the High Court in the circumstances of the case may think fit.

(3) This section shall have effect notwithstanding any stipulation or agreement to the contrary in any lease, whether registered or not.

(4) For the purposes of this section a lease limited to continue as long only as the lessee abstains from committing a breach of agreement or condition shall be construed and take effect as a lease to continue for any longer term for which it could subsist, but determinable by a proviso for re-entry on such breach.

70. Unless a notice under section sixty-eight of this Act has been served on the lessee, the agreements and conditions contained or implied in any registered lease may be varied negatived or added to, and the term of any lease may from time to time be extended by a memorandum executed by the lessor and the lessee for the time being and registered before the expiration of the then current term of the lease.

Variation  
and  
extension  
of leases.

71. Where a lease is presented for registration and the Registrar is satisfied on such evidence as he may require that the lessee is the person registered as the proprietor of a prior lease in respect of the same land, he shall cancel the registration of the prior lease and register the new lease.

Substitution  
of leases.

72.—(1) Subject to the provisions of his lease, the proprietor thereof if the lease is registered under this Act may sublet for any period less than the remainder of the period of his lease by an instrument in the prescribed form; and unless otherwise expressly provided, the provisions of this Act affecting leases, and parties thereto shall apply to subleases and parties thereto with such adaptations as are necessary.

Subleases

(2) There shall be implied in every sublease in addition to those implied by this Act in leases, an agreement by the sublessor that he will, during the continuance of the sublease pay so much of the rent reserved by the head lease and observe and perform the agreements and conditions thereof as relate to the land in the sublease.

(3) Where any sublessee has paid to the head lessor of the land the rent or any part of the rent payable by his sublessor in respect of the head lease, the sublessee shall be entitled to set off any sum so paid against the rent payable by him to his sublessor in respect of his sublease.

(4) If a lease is determined by operation of law or by surrender under any law relating to bankruptcy, any sublease of the lease shall also be determined.

Surrender  
of leases.

73.—(1) A lease may be surrendered by an instrument of surrender in the prescribed form or by writing the word "Surrendered" with the date of surrender, on the original or the duplicate of other copy acceptable to the Registrar, and by the execution thereof by the lessor and the lessee. Upon presentation of such document duly executed and payment of the prescribed fee, the registration of the lease shall be cancelled and the interest of the lessee shall cease.

(2) No lease which is subject to a charge or a sublease shall be surrendered without the consent in writing of the proprietor of the charge or sublease.

Determina-  
tion of  
leases.

74.—(1) Where a registered lease has been determined—

(a) by effluxion of time ; or

(b) by the happening of an event upon which the lease is expressed to determine ; or

(c) by lawful re-entry and recovery of possession ;

the lessor may apply in writing to the Registrar to cancel the registration thereof.

(2) An application under this section shall be supported by such evidence of the happening of the event and of the lawful re-entry as the Registrar may require, and if the Registrar is satisfied, he shall cancel the registration of the lease, and the land shall thereupon cease to be subject to the lease.

### *Charges*

Form and  
effect of  
charges.

75.—(1) The proprietor of any land, lease or charge under this Act may by instrument create a charge thereover to secure the payment of a debt or other money or money's worth or the fulfilment of any condition, and the instrument creating the charge may be registered as an encumbrance ; but until registered, a charge under this Act shall not affect the interest of the proprietor in the land, lease, or charge.

(2) A charge under this section shall not operate as a transfer of the land charged, but shall have effect as a security only.

(3) There may be included in an instrument of charge securing the fulfilment of a condition or the payment of an annuity or other periodical payment not of the nature of interest on a capital sum, such provisions, not inconsistent with this Act, as the parties think fit for disposing of the money which may arise on the exercise by the chargee of his power of sale, either by investing the proceeds of sale or a part thereof to make future periodical payments, or by payment to the chargee of such proceeds or part thereof being the estimated capital value of the chargee's interest, or otherwise.

Second or  
subsequent  
charges.

76. The proprietor of land subject to a charge may create subsequent charges in the same manner as a first charge and the same provisions with all necessary changes shall apply thereto ; but a sale under any power express or implied in any such subsequent charge shall be subject to all prior subsisting charges.

77. Where a charge is created by a company which has its registered office or an established place of business in Nigeria, the charge shall not be registered under the provisions of this Act unless the Registrar is satisfied that the charge has been duly registered under the provisions of the Companies Act within the time therein prescribed or within such extended time as the High Court may allow.

Charges by companies.

Cap. 37.

78. There shall be implied in every charge, unless the contrary is expressed therein, agreements by the chargor with the chargee binding the chargor—

Agreements implied in charges.

(a) to pay the principal money on the day therein appointed and, so long as the principal money or any part thereof remains unpaid, to pay interest thereon or on so much thereof as for the time being remains unpaid at the rate and on the days and in manner therein specified ;

(b) to repair and keep in repair all buildings or other improvements upon the charged land and to permit the chargee or his agent, at all reasonable times until such charge is discharged and after reasonable notice to the chargor to enter upon the land and examine the state and condition of such buildings and improvement ;

(c) to insure and keep insured all buildings upon the charged land against loss or damage by fire in the joint names of the chargor and chargee with insurers approved by the chargee to the full insurable value thereof ;

(d) not to lease the charged land or any part thereof for any period longer than one year without the previous consent in writing of the chargee ; and

(e) in the case of a lease, to pay the rent as and when required thereunder and to perform and observe the other agreement and conditions on the part of the lessee to be performed and observed and to keep the chargee indemnified against all proceedings, expenses claims on account of the non-payment of the said rent or any part thereof or the breach or non-observance of the said agreements and conditions, or any of them.

79. The amount secured, the rate of interest or the term of the charge may be varied by the registration of a memorandum of variation executed by the parties thereto, but no such variation shall affect the rights of the proprietor of any subsequent charge unless he has consented thereto in writing on the memorandum of variation.

Variation of charges.

80.—(1) Subject to the provisions of this section, if at any time before it has been sold in exercise of the power of sale conferred by this Act, or before the making of a foreclosure order, as the case may be, a chargor pays or tenders payment of all moneys due and owing under the charge at the time of payment or tender of payment or on fulfilment of any condition secured thereby, he shall be entitled to redeem the land charged ; and any agreement or provision which purports to deprive the chargor of the right of redemption shall be void.

Right of redemption.

(2) If the chargor seeks to redeem the land charged before the date specified in the charge, he shall pay to the chargee, in addition to any other money then due or owing under the charge, interest on the principal sum secured thereby for the unexpired portion of the term of the charge.

(3) If the chargor seeks to redeem the land charged after the date specified in the charge, he shall give the chargee three months notice in writing of his intention to redeem the charge, or pay him three months interest in lieu thereof.

(4) If at any time the chargor is entitled and desires to repay the money secured by the charge but the chargee for any reason cannot be found, or the Registrar is satisfied that the charge cannot be discharged otherwise, the chargor may pay the amount due into the High Court to the credit of the chargee; and upon application in writing signed by the chargor and production of the receipt for the money paid into that court, the Registrar shall cancel the registration of the charge.

Notice in  
case of  
default.

81. If default is made in payment of the principal sum, or of any interest or other periodical payment or any part thereof, or in the performance or observance of any agreement, express or implied, in any charge and such default continues for one month thereafter, the chargee may serve on the chargor notice in writing requiring him to pay the money owing, or to perform and observe the agreement, as the case may be.

Power of  
sale under  
a charge.

82.—(1) If within three months after the service of a notice of default under this Act the chargor does not comply with it the chargee may, in good faith and having regard to the interests of the chargor, sell or concur with any other person in selling the charged land or any part thereof, together or in lots, by public auction for a sum payable in one amount or by instalments, subject to such reserve price and conditions of sale as the chargee thinks fit, with power to vary or to rescind any contract for sale and to resell by public auction without being answerable for any loss occasioned thereby.

(2) A transfer by a chargee in exercise of his power of sale shall be in the prescribed form, and the Registrar may accept it as sufficient evidence that the power has been duly exercised.

(3) Upon registration of such transfer the interest of the chargor as described therein shall vest in the transferee freed and discharged from all liability on account of such charge, or on account of any charge registered subsequently thereto.

Application  
of purchase  
money.

83. The purchase money received by a chargee who has exercised his power of sale shall, after discharge of any prior encumbrance to which the sale is not made subject, or if the chargees cannot be found, after payment into the High Court of a sum to meet any such prior encumbrances, be applied in the following order, that is to say—

(a) in payment of all costs and expenses properly incurred incidental to the sale or any attempted sale;

(b) in accordance with any express provision in the charge for disposing of such money and, in default of any such provision, in discharge of the money due to the chargee at the date of the sale;

(c) in payment of any subsequent charges in the order of their priority;

and the balance (if any) of the money received shall be paid to the person who, if the land or other interest had not been subject to any charge so paid off under this section and but for the transfer, would have been entitled as the proprietor to give a receipt for the sale.

84.—(1) If within three months after the service of a notice of default under this Act the chargor does not comply with it, the chargee may instead of exercising his power of sale, apply to the Registrar for the appointment of a receiver of the income, rents and profits of the charged property, or any part thereof; and the Registrar shall, on receipt of the application, appoint a fit person to be the receiver accordingly, and shall enter notice of the appointment in the land register.

Appoint-  
ment and  
duties, etc.  
of receiver.

(2) A receiver appointed under this section shall be deemed to be the agent of the chargor for the purposes for which he is appointed; and the chargor shall be solely responsible for the acts or defaults of the receiver, unless the instrument of charge otherwise provides.

(3) A receiver shall have power to demand and recover by action or otherwise, all the income of which he is appointed receiver, in the name of the chargor, and to give effectual receipts for the same; and where a person pays money to a receiver under this subsection he shall not be concerned to enquire into the validity of the appointment of the receiver.

(4) A receiver may be removed upon the application of the chargor or of the chargee, and a new receiver may at any time be appointed by the Registrar after giving both chargor and chargee an opportunity of being heard; and notice of every removal of and new appointment of a receiver shall be entered in the land register.

(5) A receiver shall be entitled to retain out of any money received by him all costs, charges, and expenses incurred by him as receiver and, for his remuneration, a commission at such rate, not exceeding five *per centum* on the gross amount of all moneys received, as may be specified in his appointment. If no rate is specified in the appointment the rate of commission shall be five *per centum* on the gross amount of all moneys received or such other rate as the chargor and chargee agree or, in default of agreement, such rate as the High Court, upon the application of the receiver may allow.

(6) Where insurance money is paid to a receiver, he shall apply it in making good the loss or damage to the property charged and in respect of which the money is received; and subject thereto the receiver shall apply all money received by him in the order following that is to say—

(a) in discharge of all rents, rates, taxes and outgoings whatever affecting the charged property; and

(b) in reduction of all annual sums or other payments, and the interests on all principal moneys, having priority to the charge in right whereof he is receiver; and

(c) in payment of his commission, costs, charges and expenses and of the premiums on fire insurance or other insurance (if any) properly payable under the charge or as prescribed by this Act, and the cost of executing necessary or proper repairs directed in writing by the chargee; and

(d) in payment of the interest accruing due in respect of any principal money secured by the charge; and

(e) in or towards discharge of the money secured by the charge if so directed in writing by the chargee,—

and the balance, if any, of the money received by him shall be paid to the person who, but for the possession of the receiver, would have been entitled to receive the income of which he is appointed receiver, or who is otherwise entitled to the charged property, as the case may be.

Foreclosure.

85.—(1) Where in intended exercise of power of sale, land charged has been twice offered under the provision of this Act for sale by public auction at an interval of not less than six months between the offers, and the amount of the highest bidding was not sufficient to satisfy the money secured by the charge together with the expenses of the sale, the chargee may apply to the High Court for an order for foreclosure.

(2) The High Court shall, upon receipt of an application under subsection (1) of this section, cause notice to be printed once in each of three successive weeks in at least one newspaper published in Lagos or published in Nigeria and circulating in Lagos offering such land for private sale, and appointing a time not less than one month from the date of the first of such advertisements, upon or after which if a sufficient amount has not been obtained by the sale of such land to satisfy the principal and interest secured and all expenses occasioned by such sale and the proceedings, the High Court will issue to the applicant an order for foreclosure.

(3) An order for foreclosure shall be forwarded for registration to the Registrar; and, when entered in the land register the order shall have the effect of vesting in the chargee the land mentioned therein freed and discharged from any interest of the chargor, and from any charge or encumbrance registered subsequent thereto, not being a lease or easement to which the chargee has consented in writing, and the debt secured by the charge shall be extinguished.

No right of entry into possession on default.

86. It is hereby declared that a chargee shall not be entitled to enter into possession of charged land or to receive the rents and profits thereof, by reason only of default made by the chargor in the payment of the principal money or of any interest or of any other periodical payment or of any part thereof, or in the performance or observance of any agreement, express or implied in the charge.

Discharge of charge.

87.—(1) A discharge, wholly or in part, may be made by an instrument in the prescribed form, or the word "Discharged" may be written on the instrument of charge; and when executed by the chargee a discharge may be registered under this Act.

(2) The discharge shall be completed by the cancellation in the land register of the charge, or part thereof as the case may be, and by filing the instrument in the Land Registry.

Satisfaction of charge.

88. Where in respect of any charge the Registrar is satisfied—

(a) that all money due has been paid to the chargee or to his credit, or

(b) that there has occurred the event or circumstances upon which the money secured ceases to be payable, and that no money is owing,

the Registrar shall order the charge to be cancelled in the land register; and thereupon the land, lease or charge affected shall cease to be subject to the charge.

89. Any instrument of charge may provide for a chargee to make further advances or give credit to the chargor on a current or continuing account ; but, unless such provision is noted in the land register, further advances shall not rank in priority to any subsequent charge without the consent in writing of the proprietor of the subsequent charge, and save as provided in this section, the right to tack is abolished.

Tacking and further advances.

90. A chargee shall have no right to consolidate his charge with any other charge unless such right is expressly reserved in the instruments of charge or in one of them and a note thereof is made in the land register against all the charges so consolidated.

Consolidation.

91. A land certificate may be deposited with any person with the intention of creating a lien over the land referred to therein ; but a deposit so made shall have no effect to charge the land until a caveat, in the prescribed form, has been registered.

No lien by deposit only of land certificate.

### Transfers

92.—(1) A proprietor may transfer his land or lease or charge by an instrument in the prescribed form ; and the transfer shall be completed by registration of the transferee as proprietor of the land, lease or charge, and by filing the instrument in the Land Registry.

Mode of transfer.

(2) The transferee of a charge may call upon any person who executed the charge, or any person claiming through him, to execute the transfer for the purpose of acknowledging the amount due under the charge at the date of execution of the transfer.

93. No part of the land comprised in any title in the land register shall be transferred unless the proprietor has first subdivided the land and new titles have been opened in respect of each subdivision.

Transfer of part.

94. On the transfer of a lease, unless the contrary is expressed in the transfer, there shall be implied—

Implied covenants, etc., on transfer of lease.

(a) on the part of the transferor, an agreement that the rent, agreements and conditions on the part of the lessee to be paid, performed and observed have been so paid, performed and observed up to the date specified in the transfer or, if no such date is specified, the date of the transfer, and to indemnify the transferee in respect thereof ; and

(b) on the part of the transferee, an agreement to pay the said rent as from the day following the date specified in the transfer or the date of the transfer, as the case may be, and to perform and observe the said agreements and conditions and to keep the transferor indemnified against all proceedings, claims and expenses on account of the non-payment of the said rent and the breach of any of the said agreements and conditions.

95.—(1) Upon the registration of a lease containing an agreement by the lessee that he will not transfer, sub-let, charge or part with possession of the land leased or any part thereof without the written consent of the lessors, the agreement shall be noted in the relevant edition of the land register and no dealing with the lease shall be registered until the consent of the lessor has been produced to the Registrar.

Restriction on transfer, etc., of lease if consent required.

(2) Any such agreement shall, notwithstanding any express provision to the contrary, be deemed to be subject to a proviso that the consent of the lessor shall not be arbitrarily or unreasonably withheld.

Implied covenants, etc., on transfer of charged land.

96. In every transfer of land subject to a charge, there shall be implied an agreement by the transferee with the transferor to pay the interest secured by the charge at the rate and at the times and in the manner therein specified, and to keep the transferor indemnified against the principal money secured by the charge, and from and against all liability in respect of any of the agreements therein contained or implied on the part of the transferor.

*Easements, Restrictive Covenants and Profits a Prendre*

Grants of easements.

97.—(1) The proprietor of land may, by an instrument in such form as the Registrar may approve, grant an easement thereover to the proprietor or lessee of adjoining or adjacent land for the benefit of that land.

(2) Any proprietor transferring or leasing land may, in the transfer or lease, reserve an easement for the benefit of adjoining or adjacent land retained by him.

(3) The instrument creating the easement shall indicate clearly—

(a) the nature of the easement, the period for which it is granted and any conditions, limitations and restrictions intended to affect its enjoyment ;

(b) the land burdened by the easement and, if required by the Registrar, the particular part thereof so burdened ; and

(c) the land which enjoys the benefits of the easement.

(4) The grant or reservation of the easement shall be completed by its registration in respect of both the land burdened and the land which benefits, and by filing the instrument in the Land Registry.

Restrictive covenants.

98.—(1) Any proprietor entitled to the benefit of a restrictive covenant (not being a covenant made between a lessor and lessee) with respect to the building on or other user of his land may apply to the Registrar to enter notice thereof in the land register ; and the Registrar shall enter notice thereof by reference to the instrument containing the covenant and shall file the notice in the Land Registry.

(2) Unless it is noted in the land register against the title to the land intended to be burdened, the restrictive covenant shall not be binding on the proprietor of such land or any subsequent person acquiring the land.

(3) The fact that a restrictive covenant is noted in the land register shall not operate to validate any defect, and accordingly any such restrictive covenant, if defective, shall have no greater effect than if it had not been so noted.

Profits a prendre.

99.—(1) The proprietor of land may, by an instrument in such form as the Registrar may approve, grant a profit a prendre (in this Part of this Act unless the context otherwise requires, referred to as a "profit").

(2) The instrument shall indicate clearly the nature of the profit its term, and whether it is to be enjoyed—

(a) in gross, or as appurtenant to other land ; and

(b) by the grantee exclusively, or concurrently with the grantor.

(3) The grant of a profit shall be completed by its registration as an encumbrance against the land affected and by filing the instrument in the Land Registry.

100.—(1) Upon production of a duly executed release in the prescribed form the registration of any easement, restrictive covenant or profit shall be cancelled and the easement, restrictive covenant or profit shall thereupon cease to have effect.

Release, etc.  
of easements,  
restrictive  
covenants  
and profits.

(2) On the application of any person affected thereby, the Registrar may cancel the registration of any easement, restrictive covenant or profit upon proof to his satisfaction,—

(a) that the period of time for which it was intended to subsist has expired; or

(b) that the event upon which it was intended to determine has occurred; or

(c) that it has been abandoned.

(3) A court on the application of any person interested in land affected by an easement, restrictive covenant or profit may order the extinguishment or modification in whole or in part of any such easement, restrictive covenant or profit on payment by the applicant in any proper case of compensation to persons thereby suffering loss, if the court is satisfied—

(a) that by reason of changes in the character of the property or of the neighbourhood or otherwise as the court thinks fit the easement, restrictive covenant or profit is or ought to be deemed obsolete, or that the continued existence of the easement, restrictive covenant or profit would impede the reasonable user of the land for public or private purposes without securing any real benefit to other persons or would, unless modified, so impede such user; or

(b) that the proposed discharge or modification will not adversely affect the persons or persons entitled to the benefit of the easement, restrictive covenant or profit, as the case may be.

#### *Proprietorship and Partition*

101.—(1) It is hereby declared that a sole proprietor may transfer land to himself for life with remainder to any other person, or may transfer any land, lease, or charge to himself and to any other person as joint proprietors or proprietors in common.

Registration  
and  
proprietor-  
ship.

(2) No registration shall be made in favour of two or more persons unless it shows whether they are to hold as joint proprietors or proprietors in common; and if the tenure is as proprietors in common and the shares are not equal, the share of each proprietor shall be expressed in a vulgar fraction with a denominator not greater than twenty.

(3) Where there is doubt in any instrument presented for registration, joint proprietorship shall be presumed to have been intended by the parties unless the contrary is therein expressed.

102.—(1) If land or any lease or charge is owned jointly, no proprietor thereof shall be entitled to any separate share; and unless otherwise prescribed by this Act, dispositions may be made only by all the joint proprietors.

Joint  
proprietors  
and  
severance of  
interest.

(2) On the death of a joint proprietor his interest shall vest in the surviving proprietors jointly, and upon proof, in such a manner as the Registrar may require, of the death of a joint proprietor the land register shall be amended accordingly.

(3) Joint proprietors, not being trustees, may execute an instrument in the prescribed form signifying that they agree to sever their joint proprietorship, and the severance shall be completed by registration of the joint proprietors as proprietors in common in equal shares and filing the instrument in the Land Registry.

(4) For the avoidance of doubt, it is declared that a joint proprietor of any land, lease or charge may transfer his interest therein to all the other joint proprietors, but shall not without the consent of all the other joint proprietors, transfer, lease or charge his interest to any other person.

Proprietorship in common.

103.—(1) Where land or any lease or charge is owned in common, each proprietor shall be entitled to a separate undivided share in the whole and on the death of such a proprietor his share shall be administered as part of his estate.

(2) No proprietor owning any land, lease or charge in common with any other person or persons shall deal with his undivided share otherwise than in favour of another proprietor in common of the same land, lease or charge without the consent in writing of the remaining proprietors thereof; but any consent required by this subsection shall not be arbitrarily or unreasonably withheld.

Partition.

104.—(1) An application in such form as the Registrar may approve for the partition of land owned in common may be made,—

(a) by any one or more of the proprietors; or

(b) by any person in whose favour an order for the sale of an undivided share in such land in execution of a decree has been made; and subject to the provisions of this or any other Act prescribing minimum areas or frontages or requiring the consent of any authority to a partition, the land shall be partitioned as agreed by the proprietors in common or, where there is no agreement, as the Registrar may by order direct.

(2) The partition of land shall be completed in the land register relating thereto by such entries as the Registrar may require and by filing the application together with the agreement or the order, as the case may be, in the Land Registry.

Power for Registrar to order sale.

105.—(1) Where for any reason land to be partitioned is unsuitable to be so dealt with, or the partition would adversely affect the proper use of the land, the Registrar shall, upon request in writing by any person claiming a registered interest and in default of agreement between the proprietors in common, value the land and the shares of the proprietors in common, and the Registrar may give effect to the request by ordering the sale of the land or the separation and sale of such shares by public auction or, as the case may require, may make such other order as he thinks fit.

(2) Any proprietor in common shall be entitled to purchase the land or any share or shares offered for sale under this section, either at the auction or by private treaty before the auction.

106.—(1) When land sought to be partitioned may be partitioned, but the share of any particular proprietor in common is or would be less in area than the minimum prescribed by any Act, the Registrar may add such share to the share of any other proprietor, or distribute such share amongst two or more other proprietors in such manner and in such proportions as, in default of agreement, he thinks fit.

Procedure where share is small.

(2) The Registrar shall assess the value of any share to be dealt with under the foregoing subsection, and thereafter may direct payment to the proprietor of such share by every proprietor receiving an addition to his share, of the value of such addition.

(3) An appeal to the High Court shall lie from any assessment and direction by the Registrar under this section, and subject thereto, the amount payable may by order of the Registrar, be secured by way of charge on the share of the person or persons liable to pay the value of the share affected.

#### *Testamentary Dispositions, etc.*

107. Nothing in this Act shall be construed to abridge or limit the right of any proprietor, other than a joint proprietor, under the law relating to testamentary dispositions to make a will disposing of his land, lease or charge on his death, or to affect the law of intestate succession.

Testamentary dispositions, etc., not affected.

#### PART VI.—INSTRUMENTS AND AGENTS

108.—(1) Dealings with any land, lease or charge under this Act shall be effected by instruments in the prescribed forms as printed for and issued by the Registrar or as the Registrar in any particular case may approve; and leases and charges shall when executed be presented for registration in triplicate.

Form of instruments.

(2) Every instrument shall, according to its nature, contain a true statement of the purchase price, or loan or other consideration; and the statement shall set out how much, if any of the purchase price, loan or other consideration has been paid or received, as the case may be.

109.—(1) Every instrument shall be executed by all parties thereto unless the Registrar dispenses with execution by any particular party as unnecessary in any particular case.

Execution of instruments.

(2) An instrument shall be deemed to have been executed—

(a) if signed by a natural person;

(b) if sealed with the common seal of a corporation affixed in the presence of and attested by its clerk, secretary or other permanent officer and by a member of the board of directors, council or other governing body of the corporation;

(c) in the case of a corporation not required by law to have a common seal, if signed by such persons as may be authorised in that behalf by any law or by the statute of the corporation or, in the absence of any express provision, by two or more persons duly appointed for that purpose by the corporation.

Proof of  
execution.

110.—(1) Unless the Registrar under the powers conferred by this section dispenses with verification, the parties executing an instrument shall appear before the Registrar or such other person as he may require or approve and, if they are unknown to the Registrar or other person as aforesaid they shall be accompanied by a credible witness or credible witnesses as the case may require for the purpose of establishing identity.

(2) The Registrar or other person before whom any party appears shall satisfy himself as to the identity of the party so appearing before him; and after ascertaining that such party has freely and voluntarily executed the instrument, the Registrar or such other person, as the case may be, shall prepare and sign a certificate to that effect. Any such certificate may be endorsed on or attached to the instrument to which it relates.

(3) The Registrar may dispense with verification under this section—

(a) if he considers that it cannot be obtained or can only be obtained with difficulty and he is satisfied by other sufficient evidence that the instrument has been properly executed; or

(b) if to his knowledge the instrument has been properly executed; and where the Registrar dispenses with verification he shall note on the instrument his reasons for dispensing with the appearance of the parties.

(4) No instrument executed out of Nigeria shall be registered unless it has endorsed thereon or attached thereto a certificate that it has been signed in the presence of a judge, magistrate, justice of the peace, notary public, or any consul, Nigerian or foreign, as the case may be.

Instruments  
to be  
stamped,  
Cap. 191.

111. No instrument liable for stamping shall be presented for registration or be registered unless it is duly stamped under the Stamp Duties Act or, as the case may require, it is endorsed as exempt from such duty by a commissioner under that Act.

Disposal  
of  
instruments.

112.—(1) Subject to the provisions of subsection (2) of this section, all instruments accepted by the Registrar shall be retained in the Land Registry for as long as they support a current entry in the relevant land register.

(2) Where the instrument registered is a lease or charge, particulars of the registration shall be noted on the duplicate and triplicate thereof, and they shall be returned to the person who presented them.

(3) Five years after an entry in the land register has been superseded or has ceased to have any effect, the Registrar may destroy the instrument which supported the entry.

Minors and  
registered  
land.

113. It is hereby declared that the name of a person under the age of twenty-one years may appear in the land register on first registration or as a transferee or on transmission; but the fact that the name of any such person appears in the land register shall not be construed so as to authorise or permit any dealing with the land or any interest in land by such person during his minority, and if to the knowledge of the Registrar a minor is so registered, the Registrar shall enter a caveat accordingly.

114.—(1) Save as provided in subsection (3) of this section, no instrument executed by any person as agent for any other person shall be accepted by the Registrar unless the person signing it was authorized in that behalf by a power of attorney executed and verified in the manner prescribed for instruments by this Part of this Act.

Agents for persons under disability.

(2) If an instrument is executed on behalf of some person by his attorney the original or, with the consent of the Registrar, an authenticated copy of the power of attorney shall be filed in the Land Registry.

(3) Where any person who, if not under disability, might have made any application, done any act or been party to any proceeding under this Act is a minor, a person of unsound mind or under any other disability, the guardian of such person, or, if there is no such guardian, then a person appointed in accordance with the provisions of any written law to represent such person, may make any application, do any act, and be party to any proceeding on behalf of any such person and shall generally represent any such person for the purposes of this Act.

(4) An instrument purporting to be signed on behalf of a person under disability shall not be accepted for registration unless the Registrar is satisfied that the person claiming to be the guardian is so entitled; and where he is not satisfied the Registrar may require production of sufficient evidence of the appointment of the person to act on behalf of the person under disability.

115.—(1) Where a power of attorney contains authority to deal with any land, lease or charge, the power of attorney shall be in the prescribed form and shall, upon the joint application of the donor and donee be filed in the Land Registry.

Power of Attorney.

(2) The donor of a power of attorney filed under this section may at any time give notice to the Registrar in the prescribed form of the revocation thereof; and after noting the power of attorney, the Registrar shall file the notice in the Land Registry.

(3) Any interested person may in writing notify the Registrar that a power of attorney filed under this section has been revoked by the death, bankruptcy or disability of the donor or by the death or disability for any reason of the donee; and subject to the production to the Registrar of such evidence as he may require, the Registrar shall note the power of attorney accordingly and file the notice in the Land Registry.

(4) Nothing in subsections (2) and (3) of this section shall apply to a power of attorney given for value and expressed to be irrevocable.

(5) A power of attorney, which has been filed under this section and of which no notice of revocation has been given under this section shall be deemed to be still subsisting; and no disposition in purported exercise of the powers therein contained shall be defeasible by reason only that the power has been revoked, unless the person for the time being claiming under such disposition had actual notice of such revocation.

Transmission on death.

PART VII—TRANSMISSIONS, TRUSTS AND FAMILY REPRESENTATION

116.—(1) Subject to the provision of this section where a joint proprietor of any land, lease or charge dies, the Registrar shall delete the name of the deceased proprietor from the land register ; and in the case of the death of any other proprietor his legal personal representative shall be entitled to be registered by transmission to the interest of the deceased proprietor.

(2) If the application is to delete the name of a joint proprietor, the applicant shall produce to the Registrar satisfactory evidence of such death.

(3) If the application is for registration as proprietor by transmission, the applicant shall apply on the prescribed form and produce therewith an office copy of probate of the will or letters of administration in the estate of the deceased proprietor, as the case may be ; and the Registrar if satisfied, shall register the applicant in place of the deceased and shall add thereafter the words "as executor" or "as administrator" with such reference to the will or to the estate as the case may require and may, if he thinks it necessary, enter a caveat to protect the interests of beneficiaries.

Registration by personal representatives not on land register.

117. Notwithstanding the provisions of section one hundred and sixteen of this Act the Registrar, upon production to him of probate or letters of administration and without requiring registration of the executor or administrator by transmission may, if he thinks fit,—

(a) register any transfer by the executor or administrator in pursuance of the will or by way of distribution under intestacy or in pursuance of an agreement between the persons entitled thereto or of a contract entered into by the proprietor in his lifetime ; or

(b) register any discharge of a charge of which the deceased person was the proprietor ; or

(c) register any surrender of a lease of which the deceased person was the proprietor.

Applications for registration on death of proprietor, etc.

118.—(1) If the executor or administrator of a deceased proprietor fails or neglects to transfer any land, lease, or charge to the persons entitled thereto, or if such land, lease or charge is not for any reason registered in the name of the person entitled thereto, such person or any judgment creditor of such person or any person claiming an interest in such land, lease or charge may, at any time after the expiration of one year from the date of the grant of probate or letters of administration, apply to the Registrar for registration by transmission of the land, lease or charge in the name of the person entitled thereto.

(2) If application is made to the Registrar under this section, he may, if satisfied that the executor or administrator has had notice of the application and that the estate has been fully administered, allow the application ; and the person entitled thereunder shall be registered accordingly.

Effect of transmission by death.

119. Where pursuant to a will or upon intestacy, any land, lease, or charge is registered in the name of or is acquired by the heir, beneficiary, executor, or administrator of a deceased proprietor, as the case may be, the person registered shall, for the purpose of any dealing with such land,

lease, or charge be deemed to have acquired it for valuable consideration, and the land, lease or charge may be dealt with accordingly; but until so dealt with the land, lease or charge shall be subject to all unregistered liabilities, rights, or interests affecting the title of, or created or imposed under the will of, the deceased proprietor.

120.—(1) A trustee in bankruptcy shall, upon application to the Registrar in the prescribed form accompanied by a certified copy of the order of court adjudging a proprietor bankrupt, or directing that the estate of a deceased proprietor be administered according to the law of bankruptcy, be registered as proprietor of any land, lease or charge in place of the bankrupt or deceased proprietor as the case may be and the entry to be made in the land register shall describe the trustee in bankruptcy as trustee of the property of (*name of proprietor*), a bankrupt.

Effect of transmission on bankruptcy.

(2) The provisions of section one hundred and nineteen of this Act shall apply to any trustee in bankruptcy as they apply to persons therein set out, but the doctrine of relation back shall have effect according to the laws of bankruptcy or the order of the court as the case may be, and not according to this Act.

121. Where the proprietor of any land, lease or charge is a company being wound up and the liquidator produces to the Registrar a certified copy of the resolution or order appointing him liquidator, together with an application in the prescribed form to have notice of the appointment entered in the appropriate land register the Registrar shall, if satisfied, enter notice thereof accordingly; and when so entered, the liquidator shall have the powers of disposition conferred on him by such resolution or order or by any written law in respect of any such land, lease or charge.

Effect of notice of liquidation.

122. Where the state or any person is entitled to any registered land under the provisions of any Act, or by virtue of any order or writ of execution, the Registrar shall, on the receipt of notice thereof in such form as he may require, register the state or such person as the proprietor thereof.

Registration of transmission by expropriation, etc.

123.—(1) Any person who acquires any land, lease or charge in a fiduciary capacity may be described by that capacity in the instrument of acquisition and be registered with the addition of the words "as trustee"; but otherwise particulars of any trust shall not be entered in the land register, and the fact that a person is registered as trustee shall not be construed as notice of, or require any person to enquire into particulars of, the trust.

Trust not to be entered on land register.

(2) Any instrument or certified copy thereof declaring a trust may be deposited with the Registrar for safe custody; but such instrument or copy when deposited shall not form part of the land register.

(3) Where the proprietor of land or of any lease or charge is a trustee, he shall hold the same subject to any unregistered liabilities, rights or interests to which the land, lease or charge is liable by virtue of the instrument creating the trust; but for the purpose of registration of any dealings, he shall be deemed to be the absolute proprietor thereof.

124. If two or more proprietors are entitled to be or are registered jointly as administrators or executors of a deceased person or otherwise as trustees, and the survivor of such proprietors would not be entitled to exercise alone the powers vested in them, the Registrar shall, upon request in writing or of his own motion, enter the words "no survivorship" in the appropriate land register.

Trustees with no survivorship.

Appoint-  
ment of  
family  
representa-  
tives.

125.—(1) Where the name of a family has been registered in respect of any land but no family representatives have been appointed, the family may, at any time, hold a family meeting for the purpose of appointing not more than twenty persons to represent the family ; and upon application in writing to him in that behalf accompanied by a list of names of the persons so appointed, the Registrar shall, if he is satisfied that such meeting was after due notice properly held, enter the names in the land register.

(2) If the registration of a disposition or transmission would result in the entry in the land register of more than twenty persons as proprietors of any land, lease or charge, the Registrar shall refuse the application unless partition is sought, and require the family to appoint representatives in the manner prescribed by this Act.

Removal and  
replacement  
of family  
representa-  
tives.

126.—(1) The Registrar, on proof to his satisfaction of the death of a family representative, shall delete the name of such representative from the land register.

(2) The Registrar on the application of any member of the family and after giving the remaining family representatives an opportunity of being heard, may delete from the land register the name of any family representative if he is satisfied that such family representative is by reason of mental or physical incapacity, absence or imprisonment, unable to act.

(3) If a family representative notifies the Registrar in writing that he no longer wishes to act as a family representative the Registrar shall delete his name from the land register and inform the remaining family representatives of the fact.

(4) Upon application in writing by a member of the family, the Registrar after such enquiries as he thinks fit, may amend the land register to add names to the list of family representatives but so as not to increase their number to more than twenty.

(5) The High Court, may at any time, on the application of a member of the family order the name of any family representative to be deleted from the land register, and the Registrar shall, upon receipt of a certified copy of the order, delete the name off accordingly.

(6) Notwithstanding the deletion from the land register of the names of any family representatives, while two or more family representatives remain thereon, they shall have all the powers of family representatives appointed under this Act ; but nothing in this subsection shall be construed to prohibit a sole representative when duly appointed from exercising the powers of family representative under this Act.

Effect of  
registration  
of family  
representa-  
tives.

127.—(1) Subject to any caveat entered in the land register, the family representatives shall, when registered, have the exclusive right of dealing with the family land, or with any lease or charge.

(2) Nothing in this Act shall relieve any person registered as the family representative from any duty, customary or otherwise, to consult other members of the family, and a person so registered shall be bound to exercise the powers vested in him by this Act on behalf and for the collective interest of the family ; but any person dealing with him in good faith and for valuable consideration shall not be concerned to

inquire whether the family representative has complied with this subsection, and any such failure by the family representative shall not confer any right to indemnity under this Act.

#### PART VIII.—JUDGMENTS AND WRITS OF EXECUTION

128.—(1) Where a court issues a judgment or writ of execution affecting any land, lease or charge, a certified copy of the judgment or writ, as the case may be, shall be sent by the registrar of the court to the Registrar under this Act with particulars of the land, lease or charge affected thereby for registration against such land, lease or charge ; but no judgment or writ of execution shall bind or affect the land, lease or charge, until it is registered.

Power to  
register  
judgments,  
etc.

129. While any judgment or writ of execution continues to be registered against any land, lease or charge, the Registrar shall not accept for registration any instrument in respect of such land, lease or charge, which is inconsistent therewith.

Effect of  
registration  
of judgment,  
etc.

130. Registration of a judgment or writ of execution shall be cancelled,—

Cancellation  
of registra-  
tion of  
judgment,  
etc.

(a) at the request in writing of the judgment creditor or other person for whose benefit the judgment or writ of execution was issued ; or

(b) on proof to the satisfaction of the Registrar that the judgment or writ of execution has been satisfied, or has lapsed in accordance with any Act or rules of court for the time being in force.

131.—(1) Where under the provisions of section fifty of the Sheriffs and Civil Process Act a court within the meaning of that Act has granted a certificate on absolute sale to the person declared to be the purchaser of immovable property which is subject to this Act, that section shall have effect as if there were added after the word "interest" where it secondly occurs, the words "when duly registered under the Registered Land Act 1964" ; and the said section shall, for the purposes only of this subsection, be deemed to be so amended accordingly.

Sale in  
execution.  
Cap. 189.

(2) The sheriff or other person authorised by him shall deduct from the proceeds of the sale the registration fee for the certificate to which the foregoing subsection relates ; and shall forward such registration fee together with the certificate to the Registrar. Upon receipt thereof and the payment of stamp duty (if any), the Registrar shall enter in the relative land register the name of the person described in the certificate as purchaser of the land, lease or charge, as the case may be, and thereafter the Registrar shall file the certificate.

#### PART IX.—CAVEATS, ETC.

132.—(1) Any person claiming an unregistered right or interest in, or to have presented a bankruptcy petition against the proprietor of, any registered land, lease or charge, may lodge with the Registrar a caveat in the prescribed form ; and when entered in the land register, no disposition of the land, lease or charge shall, save to the extent to which the caveat may permit or allow, be registered or any entry affecting the same made, until notice under this Act has been served on the caveator, and the caveat has lapsed or the caveator consents in writing to the registration.

Caveats  
generally.

1963, No. 23.

(2) A caveat shall set out briefly the right or interest claimed by the person lodging it ; and the Registrar may require such person to support the claim by a statutory declaration under the Oaths Act 1963. Where he thinks it unnecessary or its purpose can be effected by the registration of an instrument under this Act he may reject the caveat ; or if he is satisfied it was lodged to protect monetary advances, he may accept it if the circumstances of the case render it expedient to do so.

(3) The Registrar shall give notice in writing of any caveat to the proprietor whose land, lease or charge is affected thereby.

(4) So long as any caveat is subsisting in the land register, no registration inconsistent with the terms of the caveat shall be effected relating to the land, lease or charge affected thereby except with the consent of the caveator or by order of a court of competent jurisdiction.

(5) A caveat may be removed from the land register with the consent of the caveator or by an order of the Court, or by the Registrar under the next succeeding subsection.

(6) The Registrar may, on the application of any person interested together with the presentation of a registrable instrument, serve notice on the caveator warning him that his caveat will be removed at the expiration of the time stated in the notice ; and at the expiration of the time stated, unless the caveator objects, the caveat shall lapse and the Registrar may remove the caveat from the land register. If the caveator objects to the removal of his caveat he shall notify the Registrar in writing of his objection within the time specified in the notice and the Registrar, after giving the parties an opportunity of being heard, shall make such order as to its removal or otherwise and as to costs as he thinks fit.

(7) A caveat entered by the Registrar under the powers conferred upon him by this Act shall be removable only with his consent, or by order of a court.

(8) Where a caveat has lapsed or been withdrawn under this section, the Registrar may refuse to accept a further caveat by the same person or anyone on his behalf in relation to the same matter as that protected by the previous caveat.

Oth.r prohibitions on registration.

**133.**—(1) For the prevention of fraud or improper dealing or for other sufficient cause a court may, on the application of any interested person in its discretion prohibit or restrict the disposition of any land, lease or charge. Any order so made, may be registered against the appropriate land register and, while it continues to be registered, shall have effect according to its tenor.

(2) The Registrar on the application by any person claiming to be interested or of his own motion and after hearing any person desirous of being heard and making such enquiries as he thinks fit, may direct the entry of a caveat against the land register, or any interest therein, as the case may be.

(3) The Registrar may enter a caveat in the land register if it appears to him there is any limitation or restriction on the power of the proprietor to deal with land, or any lease or charge.

(4) Upon the entry of a caveat the Registrar shall give notice thereof to the proprietor affected thereby.

(5) So long as any caveat is subsisting in the land register, any registration against the land, lease or change therein inconsistent with the terms of the caveat shall not be made without an order of court.

(6) The Registrar at any time upon the application of any person interested or of his own motion, and after giving the parties affected thereby an opportunity of being heard, may order the removal or variation of any caveat entered by him under this section.

(7) Upon the application of any proprietor affected by a caveat under this section, and upon notice thereof to the Registrar, the High Court may order the caveat to be removed or varied, or the court make such other order, including an order as to costs, as it thinks fit.

#### PART X—ADVERSE POSSESSION AND PRESCRIPTION

134.—(1) Ownership of land may be acquired by peaceable, overt and uninterrupted adverse possession thereof—

- (a) against the state for a period of twenty years ; and
- (b) in any other case for a period of twelve years

(2) Any person claiming to have acquired land by virtue of the provisions of subsection (1) of this section may, after having advertised or given notice in such manner as the Registrar may direct, apply to the High Court for an order requiring him to be registered as the proprietor thereof.

135.—(1) Where it is shown that a person has been in possession of land or in receipt of the rents or profits thereof at a certain date, and such person is still in possession or receipt thereof, it shall be presumed that he has from that date, as to the land or the rents or profits as the case may be, been in continuous possession or receipt thereof until the contrary is shown.

(2) Possession of land or receipt of the rents or profits thereof by any person through whom a claimant derives title shall be deemed to have been possession or receipt of the rents or profits by the claimant.

(3) Where from the relationship of the parties or any other special cause it appears that the person in possession of land is or was in possession on behalf of another, his possession shall be deemed to be or to have been the possession of that other.

(4) If a person, whose possession of land is subject to conditions imposed by or on behalf of the proprietor, continues in such possession after the expiry of the term during which such conditions subsist without fulfilment or compliance with them by such person and without any exercise by the proprietor of his right to the land, such subsequent possession shall be deemed to be peaceable, overt and uninterrupted adverse possession, available for the purposes of this Act ; and in the application of this subsection—

(a) a tenancy at will shall be deemed to have determined at the expiration of a period of one year from the commencement thereof unless it has previously been determined, and

(b) a tenancy from year to year or other period shall be deemed to have determined at the expiration of the first year or other period, but where any rent is subsequently paid in respect of the tenancy, it shall be deemed to have determined at the expiration of the period for which the rent has been paid.

Acquisition  
of land by  
adverse  
possession.

Principles of  
possession.

(5) Where at any time during the period prescribed by this Part of this Act, the true owner is under any legal disability, the period of such disability shall not be counted unless a court upon application made to it by the claimant or the owner or other person interested, otherwise directs; and for the purposes of this subsection and the giving of a direction the court shall have power to hear and dispose of the case by motion of which notice has been given under rules of court.

(6) Possession of land shall be interrupted—

(a) by physical entry thereon by any person claiming it in opposition to the person in possession with the intention of causing interruption and the possessor thereby loses possession; or

(b) by the institution of legal proceedings by the proprietor to assert his right thereto; or

(c) by any acknowledgment admitting the claim made by the person in possession to any person claiming to be the proprietor thereof.

(7) A person holding land in a fiduciary capacity shall not acquire title to the land by adverse occupation against the beneficial owner thereof.

Acquisition  
of easements,  
etc., by  
prescription.

136.—(1) Subject to the provisions of the next succeeding subsection, easements and profits a prendre may be acquired without registration by peaceable, overt and uninterrupted enjoyment thereof, if the land adversely affected thereby is state land, for a period of twenty years, and in any other case by such enjoyment for a period of twelve years.

(2) An easement or profit a prendre shall not be acquired by reason of enjoyment under the foregoing subsection unless the proprietor of the land burdened by such easement or profit a prendre knows or ought to have known of the enjoyment and might have prevented it by his own act.

(3) Any person claiming to have acquired any easement or profit a prendre by prescription under this section may, after notice thereof given in such manner as the Registrar may direct, apply to the High Court for an order directing entry of a record of the easement or profit a prendre, as the case may be, in the land register.

This Part not  
to apply to  
registered  
land.

137. After land becomes subject to this Act, no title thereto by adverse possession shall be acquired, and no easement or profit a prendre thereover shall be acquired by prescription; and this Part of this Act shall cease to have effect as to any such land accordingly.

#### PART XI.—REGISTERED LAND ASSURANCE FUND AND RECTIFICATION OF LAND REGISTER

Assurance  
Fund.

138.—(1) There shall be established a fund to be called the Registered Land Assurance Fund (in this Act referred to as "the Assurance Fund") into which shall be paid all moneys collected under this Part of this Act; and subject to the provisions of this section, moneys in the fund shall be available for the payment of claims under this Act.

(2) No claim shall be admitted or allowed by the Registrar unless the claimant satisfies the Registrar that he has exhausted all rights of action against his predecessor in ownership before making a claim under this Part of this Act, and the claim is thereafter certified for payment by the Registrar and approved by the Minister. Where the amount is in dispute, a court may direct the claim to be so certified by the Registrar.

(3) Moneys in the Assurance Fund shall, for the purpose of control and management, be deemed to be part of the public funds of Nigeria, and subject to the provisions of the Finance (Control and Management) Act 1958; and accordingly that Act shall apply save that interest earned shall accrue to the Assurance Fund and not form part of the Consolidated Revenue Fund.

No. 33 of  
1958.

139.—(1) There shall be paid to the Registrar on the first registration after land is brought under the provisions of this Act, in addition to any registration fee such amount as may be prescribed, not exceeding in any case a rate of one halfpenny in the pound on the value of the land with all improvements existing thereon when so brought under this Act; and the Registrar may accept a certificate by the proprietor of the value for such purpose, or require a valuation to be made by a competent valuer.

Payment to  
Assurance  
Fund on  
first  
registration.

(2) Moneys so collected which are additional to the registration fees, shall be paid by the Registrar into the Assurance Fund.

(3) Any certificate given under this section shall be deemed to be a declaration as to value, and shall be construed and have effect accordingly.

140.—(1) The Registrar may at any time with the consent of all persons interested, rectify entries in the land register; and of his own motion may amend the land register, or correct errors or supply omissions therein where they do not materially affect the interests of the proprietor, or where they relate to matters of form only.

Rectification  
by Registrar

(2) Upon proof of the change of the name or address of any proprietor the Registrar shall, on the application in writing of the proprietor, amend the land register accordingly.

141.—(1) Subject to the provisions of subsection (2) of this section a court may in any of the following cases order cancellation or amendment of a land register—

Rectification  
by court.

(a) where by mistake two or more persons have been registered as proprietors of the same land, lease or charge;

(b) where the court is satisfied that any registration (other than registration made pursuant to an adjudication record under this Act) has been obtained, made or omitted by fraud or mistake;

(c) where it is necessary to supply any material omission;

(d) where any person appears from the record to have acquired land or an interest in land by prescription under Part X of this Act; and upon production of a certified copy of the order and payment of the prescribed fee, the Registrar shall amend the land register accordingly.

(2) An entry in the land register shall not be cancelled or amended so as to affect adversely the title of a proprietor who is in possession unless such proprietor is a party or privy to the omission, fraud or mistake in consequence of which cancellation or amendment is sought, or has caused such omission, fraud or mistake or substantially contributed thereto by his act, neglect or default.

142.—(1) Subject to the provisions of this Act, any person suffering loss by reason of—

Right to  
indemnity.

(a) any rectification of the land register under this Act other than in the case of acquisition by adverse possession or by prescription; or

(b) any mistake or omission in the land register which cannot be rectified under this Act, and the mistake or omission is one not arising in a first registration out of an adjudication record under this Act ; or

(c) any error in a copy of or extract from the land register or from any instrument or plan certified under the provisions of this Act ;

may claim against the Assurance Fund in proper case, and if there are insufficient moneys in the Assurance Fund, the Federal Minister of Finance upon application made by the Registrar and approved by the Minister may, if satisfied, authorise payment out of the Contingencies Fund subject to such conditions as he may prescribe.

Cf. 1958 No. 33.

(2) No indemnity shall be payable under this Act to any person who has himself caused or substantially contributed to the loss by his fraud or negligence, or who derives title (otherwise than under a registered disposition for value) from a person who so caused or substantially contributed to the loss.

Costs, etc.,  
on any claim.

143. The Registrar when considering any claim against the Assurance Fund may take into account any costs and expenses properly incurred.

Restriction  
on claims in  
respect of  
surveys.

144.—(1) Where the boundaries of any registered land are defined without sufficient survey or by reference only to any survey of adjacent land and the land register is noted as limited as to parcels or to the like effect, no claim shall lie against the Assurance Fund in respect of any alteration in area by reason of the survey of such land made at any time thereafter.

(2) As between the state and a proprietor, no claim to compensation shall arise and no suit shall be maintainable on account of any surplus or deficiency in the area of any land disclosed by a survey forming the basis of the title and any subsequent survey of that land.

(3) As between a proprietor and any person from or through whom he acquired the land, no claim to compensation shall be maintainable on account of any surplus or deficiency in the area thereof disclosed by a survey showing a different area from that in any other survey, or from the area shown in the land register after a period of six months from the date of registration of the instrument under which the proprietor acquired the land.

Amount of  
indemnity.

145. Where a claim is allowed against the Assurance Fund in respect of the loss of land or any interest in land and there is no rectification of the land register, the amount paid shall not exceed the value of the land or interest at the time when the mistake or omission which caused the loss was made ; and in any other case, the amount paid shall not exceed the value of the land or interest immediately before the time of rectification.

Power to  
enforce  
covenant  
where  
indemnity  
paid.

146. If indemnity is paid under this Part of this Act, the Minister may if he thinks fit, enforce any express or implied covenant or other right which the person who is indemnified would have been entitled to enforce in relation to the matter in respect of which the indemnity has been paid.

## PART XII—DECISIONS OF REGISTRAR AND APPEALS

147. If any question arises with regard to the performance of any duty or the exercise of any functions by this Act conferred or imposed on him, the Registrar may state a case for the opinion of the High Court; and when given, the opinion shall be binding upon the Registrar.

Power for Registrar to state a case.

148.—(1) Any person aggrieved by a decision or order of the Registrar, may, within one month from the date of the decision or order, give notice to the Registrar in the prescribed form of his intention to appeal to the High Court against such decision or order.

Appeal against decision of Registrar.

(2) On receipt of a notice of appeal, the Registrar shall prepare and send to the High Court and to the appellant, and any other person appearing by the land register to be affected by the appeal, a brief statement of the question in issue.

(3) The High Court after hearing all interested parties may make such order on the appeal as the circumstances may require, and any order made shall if there is no further appeal, be binding on the Registrar.

(4) An appeal shall lie from an order of the High Court to the Supreme Court and shall be made within such time as rules of court may prescribe in the case of appeals relating to land in civil cases, as nearly as may be.

(5) The costs of the appeal shall be in the discretion of the court making the order or disposing of the appeal as the case may be.

149.—(1) If an appeal to a court is pending the Registrar shall note the land register affected; and save as otherwise provided in this section, any disposition shall have effect subject to the outcome thereof.

Effect of notice of appeal on disposition.

(2) An appeal to a court shall not affect a disposition for valuable consideration registered before delivery of notice of the appeal to the Registrar.

(3) This section shall apply to an appeal from an order of a High Court to the Supreme Court as it applies to an appeal to the High Court.

150.—(1) The Chief Justice of Lagos may make rules prescribing the procedure to be followed in the conduct of appeals from decisions of the Registrar to the High Court of Lagos.

Power to make rules of court.

(2) The Chief Justice of Nigeria may, for the purposes of this Part, make rules prescribing the procedure to be followed in the conduct of appeal from the High Court.

## PART XIII.—MISCELLANEOUS AND TRANSITIONAL

151.—(1) No instrument intended for registration shall be accepted under this Act, unless it is in the prescribed form or is in such other form as the Registrar may approve.

Certification of documents.

(2) Every such instrument shall have endorsed thereon a certificate to the effect that it is correct for the purposes of the Registered Land Act, and such certificate shall be signed by the party claiming interest thereunder or by his solicitor; and no instrument shall be accepted for registration if the certificate is not so signed. The making of any false certificate for the purposes of this Act shall be an offence for which the offender shall be liable on summary conviction to a fine of fifty pounds, and the court convicting may direct the removal from the land register of the instrument, if registered.

Registration  
fees.

152.—(1) There shall be paid upon the first registration made after the bringing of land under this Act such fees in respect of the dealing therewith, additional to the contribution to the Assurance Fund under section one hundred and thirty-nine of this Act, as may be prescribed by regulations for registration of instruments under this Act.

(2) There shall be paid in respect of every instrument thereafter presented for registration or otherwise to be dealt with by the Registrar, such fees as may be prescribed by regulations under this Act.

(3) No instrument shall be accepted for registration or be deposited or filed after the preparation of the land register in respect of land subject to this Act, until the fees so prescribed for the instrument have been paid.

Addresses of  
caveators  
and others to  
be given to  
Registrar.

153. Any person who, under the provisions of this Act, submits a caveat or any instrument for registration, or appears on the land register as the proprietor of any land, lease or charge shall, if required, give to the Registrar in writing a postal address for service within the Federal territory, and shall give notice in writing to the Registrar of any subsequent change in the address.

Services of  
notices.

154. A notice under this Act shall be deemed to have been served on or given to any person—

- (a) if it is served on him personally ; or
- (b) if it is left for him at his last known address ; or
- (c) if it is sent by registered post to him at his last known address

Hearings and  
opportunity  
of being  
heard.

155.—(1) Where a thing may be done after a hearing or after giving a person an opportunity of being heard before the Registrar, it shall be sufficient for the purposes of this Act if the person concerned—

- (a) attends in person or by a legal practitioner or other agent, and is heard or states that he does not desire to be heard ; or
- (b) having received notice appointing a place and time, not less than seven days after service, at which he will be heard with reference to the matter or thing in the notice, fails to attend the hearing.

(2) Notwithstanding the provisions of subsection (1) of this section, the Registrar in his discretion and whether or not the person concerned so attends or after notice given fails to attend, may adjourn the hearing from time to time ; and any such person may thereafter be heard at any subsequent meeting so adjourned.

(3) Where by this Act persons appearing by the land register or any document in the possession of the Registrar to be interested or affected are to be given an opportunity of being heard, it shall be sufficient if all persons who, according to any subsisting entry in the land register or by such document, as the case may be, appear to be so interested or affected, are given such an opportunity.

156. No officer of the Land Registry or officer engaged for the purposes of adjudication under Part I of this Act shall be liable to any action, suit or proceeding for or in respect of any act matter or thing in good faith done or omitted to be done in exercise or purported exercise of the powers conferred upon any such officer by this Act.

Indemnity  
of officers.

157.—(1) Any person who—

Offences.

(a) knowingly misleads or deceives any person authorised under this Act to require information in respect of any land or interest in land; or

(b) fraudulently procures, assists in fraudulently procuring or is privy to the fraudulent procurement of any land certificate or instrument, or of any entry, erasure or alteration in the land register, or in any form issued by the Registrar; or

(c) fraudulently uses, assists in fraudulently using or is privy to the fraudulent using of any instrument or form purporting to be issued or authorised by the Registrar; or

(d) fraudulently removes from the Land Registry any part of a land register or any instrument filed in the Land Registry or causes any defacement, obliteration, mutilation or unauthorized entry or alteration to be made thereto,

shall be guilty of an offence, and liable on conviction on indictment to a fine of five hundred pounds or to imprisonment for a term of three years, or to both, or liable on summary conviction to a fine of one hundred pounds or to imprisonment for a term of six months, or to both.

(2) If any person fails without lawful excuse to comply with any order or direction of an adjudication officer he shall be guilty of an offence and be liable on summary conviction to a fine of one hundred pounds or to imprisonment for a term of six months, or to both.

(3) If any person after delivery to him of a summons issued under this Act, wilfully neglects or refuses to attend in pursuance of such summons, or to produce any map, plan, instrument or other document which he is required to produce for the purposes of this Act, or to answer upon oath or otherwise any question which may be lawfully put to him by the Registrar or any other officer he shall be guilty of an offence and be liable on conviction to a fine of twenty pounds.

158.—(1) The Registrar may register any instrument notwithstanding the failure for any reason to pay the prescribed fee or any part thereof; but in any such case a note of the fee or part of the fee remaining unpaid shall be entered in the land register, and the Registrar may refuse to register any further disposition of any land, lease or charge while a fee so noted is unpaid.

Additional  
powers of  
Registrar.

(2) The Registrar may, accept the amount of the consideration for the purpose of determining the registration fees payable as the value of any land under this Act; or may appoint a valuer and act on his certificate of valuation.

159. Expenses incurred by the Registrar and unpaid fees shall constitute a debt and may be recovered in legal proceedings brought by the Registrar.

Recovery of  
unpaid fees,  
etc.

160. An order for the payment of money made by the Registrar in the exercise of any power conferred upon him under this Act shall be deemed to be an order of a court and be enforceable in like manner.

Enforcement  
of Registrar's  
orders of  
payment.

Regulations. **161.** Subject to the provisions of this Act, the Minister may make regulations prescribing—

- (a) the forms for use under this Act ;
- (b) the fees to be paid under this Act or on the use of forms submitted for approval ;
- (c) any other matter or thing, necessary for any of the purposes of this Act.

Registration of instruments in special cases.

**162.** Notwithstanding the provisions of this Act as to the requirements of form for any instrument, if the Registrar is satisfied that an instrument is otherwise in order for registration and was executed before the date of the constitution of the land register intended to be affected or was executed within six months after that date, he may register the instrument on payment of the appropriate fees and certification of the instrument as prescribed by this Act.

Restricted application of other Acts.

**163.—(1)** Where by reason of the declaration of an adjudication area this Act is to apply and a land register is opened for land brought under the provisions thereof, the Acts mentioned in the Schedule to this Act shall, with reference to any such land, cease to have effect.

(2) Where any land is subject to this Act nothing herein shall, unless the contrary intention is shown, be construed as permitting any act, matter or thing otherwise prohibited by any other Act, or as dispensing with the requirement of any Act which prescribes approval by any person to any act, matter or thing.

(3) In its application to the Federal territory, the Conveyancing and Law of Property Act 1881 of the United Kingdom shall, to the extent to which other provision is made by this Act, cease to have effect ; and in particular, the provisions of sections twenty-six, twenty-seven, twenty-nine and fifty-seven and of the Third and Fourth Schedules of the said Act (which together prescribed certain forms) shall, save as to the form of marriage settlement, be repealed.

Interpretation.

**164.—(1)** In this Act unless the context otherwise requires—

“adjudication area” means any area to which this Act is applied, and “adjudication section” means any subdivision thereof made for the purposes of an adjudication under this Act ;

“adverse possession” includes the receipt of rent by a person wrongfully claiming the land in reversion ;

“Assurance Fund” means Registered Land Assurance Fund established for the purposes of claims under this Act ;

“certificate of title” means a certificate of title issued under the provisions of the Registration of Titles Act ;

“charge” means an interest in land securing the payment of money or money’s worth or the fulfilment of any condition and includes the interest in land known as mortgage, and “sub-charge” shall have the corresponding meaning ;

“chargee” means the proprietor of a charge ;

“chargor” means the proprietor of charged land or of a charged lease ;

“court” or “the court” means the High Court of Lagos and includes any court of superior jurisdiction ;

“demarcation officer” means an officer appointed under this Act to survey or otherwise mark out land within an adjudication area ;

“demarcation plan” means a plan prepared for an adjudication under this Act ;

Cap. 181.

"disposition" means any act performed *inter vivos* whereby the rights of persons in or over land or any lease or charge are affected otherwise than by an executory contract or agreement, and includes any acquisition by operation of law ;

"easement" means any right which may be the subject of a deed of grant attaching to land whereby the use by the proprietor of the land is or may be restricted, or the use without ownership or occupation of the land is or may be enjoyed by the proprietor of adjoining or adjacent land ;

"edition" with reference to the land register means the current title to land or to any lease thereof, as the case may be ;

"encumbrance" includes any lease or charge capable of being registered under this Act ;

"guardian" means any person under customary law or otherwise responsible for protecting the interest of any person under disability by reason of age, unsoundness of mind or other cause whatsoever ;

"the High Court" means the High Court of Lagos ;

"instrument" includes any deed, judgment, decree, order or other document in writing requiring or capable of registration under this Act ;

"land" includes all things growing thereon and buildings and other things permanently affixed thereto, and where land is covered with water, the land itself, but does not include water, or any mine, minerals, mineral oil or mineral gas ;

"land certificate" means a certificate as evidence of ownership and other matters issued under this Act ;

"land register" means the current edition of the register of land evidencing ownership by a proprietor under this Act, and includes a register of any lease thereof and any former register compiled for the purposes of this Act, and references to registration or entries therein shall be references to registration or entries in the relevant edition of the land register ;

"land registration district" means a district constituted for the purposes of registration of land under this Act ;

"Land Registry map" means the map compiled from a demarcation plan and kept by the Registrar for the purposes of this Act ;

"lease" includes sublease but not an agreement for a lease ;

"lessee" means the holder of a lease ;

"lessor" means the proprietor of leased land ;

"Minister" means the Federal Minister for the time being charged with responsibility for registration of land ;

"mutation record" means a record of changes in the Land Registry map kept by the Registrar under this Act ;

"parcel" means any area of land separately shown on the Land Registry map ;

"powers" when used in reference to the Registrar and his subordinates, includes duties ;

"presentation book" means the book in which are recorded all applications for registration under this Act ;

"profit a prendre" means a right to enter on the land of another and take substance therefrom either of the soil or products of the soil ;

"proprietor" means the person registered under this Act as the owner of land or of any lease or charge ;

"registered land" means land registered under this Act ;  
 "registration officer" means the person appointed for the purposes of any adjudication under this Act ;

"Registrar" means the Registrar of Land under this Act and includes a deputy registrar and, to the extent to which he may be authorised by the Registrar, an assistant registrar ;

"registration section" means a division of a land registration district made by the Registrar on the Land Registry map ;

"transfer" means the acquisition of land, or any lease or charge by act of the parties and not by operation of law, and includes the instrument by which any such acquisition is effected ;

"transmission" means the acquisition of land or of any lease or charge by operation of law, and where land may be acquired compulsorily under any Act, includes any such acquisition ;

"valuable consideration" does not include any nominal consideration in money.

Cap. 181.

(2) References to registration means references to the making of any entry, note, or record in the land register under the provisions of this Act or, as the case may require, of the Registration of Titles Act, and cognate expressions shall have such extended meaning.

(3) References to an heir,—

(a) where used in relation to registered land which before or after the commencement of this Act is affected by customary law, or to other registered land if before the commencement of this Act, the proprietor or any person beneficially entitled has died or executed any deed or instrument importing a reference to an heir, or

(b) where used in relation to unregistered land the subject of an investigation under this Act,

shall be construed and have effect as if this Act had not been passed ; and in any other case the references shall be construed to refer to the personal representatives or other persons beneficially entitled.

(4) References to marriage expressed as consideration in any instrument, shall be construed as valuable consideration for the purposes of this Act.

Short title,  
application  
and  
commence-  
ment.

165.—(1) This Act may be cited as the Registered Land Act, 1964, and shall apply to the Federal territory.

(2) This Act shall come into operation on a date to be fixed by the Minister by order in the Gazette.

## SCHEDULE

Section 163(1)

Enactments Affected		
Chapter	Short Title	Extent affected
14	Arotas (Crown Grants) Act	The whole Act
44	Crown Grants (Lagos) Act	The whole Act
45	Crown Lands Act	Sections 31 and 33
61	Epetedo Lands Act	The whole Act
75	Glover Settlement Act	The whole Act
99	Land Registration Act	The whole Act
181	Registration of Titles Act	The whole Act

L.N. 66 of 1964

MAGISTRATES' COURT (LAGOS) ACT (CAP. 113)

The Magistrates' Court (Civil Procedure)  
(Amendment) Rules, 1964

Commencement : 1st April, 1963

In exercise of the powers conferred on me by section 77 of the Magistrates' Court (Lagos) Act and of all other powers enabling me in that behalf, I hereby with the approval of the President make the following Rules—

1. The Rules may be cited as the Magistrates' Court (Civil Procedure) (Amendment) Rules, 1964 and shall be deemed to have come into effect from the 1st April, 1963.

Citation  
and  
commence-  
ment.

2. Rule 6 of Order VI of the Magistrates' Court (Civil Procedure) Rules, which relates to the person who may effect service, is amended by the addition thereto of the following proviso—

Amend-  
ment of  
Order VI  
Rule 6.

"Provided that service of any notice of determination of tenancy or of intention to recover possession under the Recovery of Premises Act, may be served by the landlord or his agent as if he were a bailiff."

MADE at Lagos this 29th day of May, 1964.

M. C. NAGEON DE LESTANG,  
*Chief Justice of Lagos*

EXPLANATORY NOTE

This amendment has the effect of enabling the landlord or his agents to effect service of notices required to be served under Section 28 of the Recovery of Premises Act, Cap. 176.

THE NATIONAL HONOURS ACT, 1964  
(1964, No. 5)

The Honours Warrant, 1964

Commencement : 1st October, 1963

ARRANGEMENT OF ARTICLES

1. Establishment, etc. of Orders of Federal Republic and Niger.
2. Eligibility for appointment to orders.
3. Mode of appointment to orders, etc.
4. Insignia.
5. Use of initials.
6. Consequences of promotion in rank.
7. Deprivation.
8. Citation and commencement.

In exercise of the powers conferred on me by the National Honours Act, 1964, and of all other powers enabling me in that behalf, I, Nnamdi Azikiwe, President of the Federal Republic, hereby make the following warrant :—

Establishment, etc. of Orders of Federal Republic and Niger.

1.—(1) There are hereby established two Orders of Dignity which shall be known respectively as the Order of the Federal Republic and the Order of the Niger (and are hereafter in this warrant referred to as "the orders").

(2) Each of the orders shall consist of four ranks of which the first and highest shall be that of Grand Commander, the second that of Commander, the third that of Officer and the fourth that of Member of the order.

(3) Subject to article 2 of this warrant, the numbers of persons appointed to the different ranks of the orders in any calendar year shall not exceed—

(a) in the case of Grand Commander, two as respects the Order of the Federal Republic and four as respect the Order of the Niger ;

(b) in the case of Commander, twenty as respects each order ;

(c) in the case of Officer, fifty as respects the Order of the Federal Republic and one hundred as respects the Order of the Niger ; and

(d) in the case of Member, one hundred as respects each order.

Eligibility for appointment to orders.

2.—(1) Subject to paragraph (2) of this article, a person shall not be eligible for appointment to any rank of an order unless he is a citizen of Nigeria.

(2) A person other than a citizen of Nigeria shall be eligible for appointment as the honorary holder of any rank of an order ; and appointments made in pursuance of this paragraph shall be disregarded for the purposes of paragraph (3) of the foregoing article.

3.—(1) The President shall by notice in the Gazette signify his intention of appointing a person to a particular rank of an order.

Mode of appointment to orders, etc.

(2) Subject to the next following paragraph, a person shall be appointed to a particular rank of an order when he receives from the President in person, at an investiture held for the purpose,—

(a) the insignia appropriate for that rank ; and

(b) an instrument under the hand of the President and the public seal of the Federation declaring him to be appointed to that rank.

(3) If in the case of any person it appears to the President expedient to dispense with the requirements of paragraph (2) of this article, he may direct that that person shall be appointed to the rank in question in such a manner as may be specified in the direction.

(4) It shall be the duty of the Secretary to the President or of such other officer as the President may determine, to establish and maintain a register in respect of each order and to enter in the register particulars of the persons appointed to different ranks of the order.

4.—(1) Subject to the following provisions of this article, the insignia Insignia. of each rank of the orders shall consist of—

(a) a medal having, on the obverse, the arms of the Federal Republic surmounting the words "For distinguished public service" and upon the reverse the initial letters of the designation of the rank in question of the relevant order and, on the reverse, a representation of the map of Nigeria surmounting the words "Federal Republic of Nigeria"; and

(b) a ribbon attached to the medal and divided laterally into three equal divisions, of which the middle division shall be white and the others green.

(2) The medal aforesaid shall be—

(a) in the case of the Order of the Federal Republic—

(i) as respects a Grand Commander, of gold, circular, and of a diameter of four inches ;

(ii) as respects a Commander, of gold, in the shape of a heart, and measuring three inches at its largest dimension ;

(iii) as respects an Officer, of silver, oval, and measuring two inches at its largest dimension ; and

(iv) as respects a Member, of bronze, in the shape of a heart, and measuring one and a half inches at its largest dimension ;

(b) in the case of the Order of the Niger—

(i) as respects a Grand Commander, of gold, circular, and of a diameter of three and a half inches ;

(ii) as respects a Commander, of silver, in the shape of a heart, and measuring two and a half inches at its largest dimension ;

(iii) as respects an Officer, of bronze, oval, and measuring two inches at its largest dimension ; and

(iv) as respects a Member, of bronze, circular, and of a diameter of one and a half inches.

(3) The ribbon aforesaid shall be of silk and shall be two inches wide in the case of a Grand Commander or Commander of each order and one inch wide in any other case.

(4) The medal shall be worn suspended by its ribbon—

(a) from the neck of its wearer in the case of a Grand Commander or Commander of each order; and

(b) from the left breast of the outer garment of its wearer in any other case;

so however that in the case of an appointment made in pursuance of paragraph (2) of article 2 of this warrant the medal may be worn in such other manner as the President may determine.

Use of initials.

5. A person appointed to any rank of an order may use after his name the letters appearing on the exergue of the medal of that rank.

Consequences of promotion in rank.

6. A person appointed to any rank of an order shall—

(a) cease to hold any lower rank of the same order to which he may previously have been appointed; and

(b) cease to be entitled to use the insignia and initials of any such lower rank; and

(c) forthwith deliver up any such insignia to, or in accordance with the directions of, the Secretary to the President.

Deprivation.

7.—(1) If it appears to the President, after such inquiry (if any) as he thinks fit, that the holder of any rank of an order has conducted himself in a manner inconsistent with the dignity of the order, the President may by notice in the Gazette deprive him of that rank.

(2) On the publication of such a notice in respect of any person—

(a) the officer charged with the duty of maintaining the register established in pursuance of this warrant in respect of the relevant order shall forthwith strike the particulars of that person from the register; and

(b) that person shall forthwith deliver up any insignia of the order received by him to, or in accordance with the directions of, the Secretary to the President.

Citation and commencement.

8. This warrant may be cited as the Honours Warrant, 1964, and shall have effect as if it had been made on the first day of October, 1963.

MADE at Lagos, this 9th day of May, 1964.

NNAMDI AZIKIWE,  
*President of the Federal Republic*

(886A)





THE MERCHANT SHIPPING  
(RADIO AND DIRECTION-FINDERS) RULES, 1964

ARRANGEMENT OF RULES

PART I—GENERAL

1. Citation and commencement.
2. Application Parts I to IV.
3. Interpretation.
4. Classification of ships.
5. Provision of radio installations.
6. Climatic and durability tests.
7. Interference with reception.
8. High voltage parts.
9. Charging of batteries.

PART II—RADIOTELEGRAPHY

10. Main and emergency equipment.
11. Radiotelegraph room.
12. Aerials.
13. Range of transmitters.
14. Supply of electrical energy.
15. Tools, etc.
16. Exemption : Class III ships.
17. Provision of radio officers.
18. Qualifications of radio officers.
19. Radio watch by radiotelegraphy.
20. Watchkeeping.
21. Use of emergency transmitter.
22. Radio log.

PART III—RADIOTELEPHONY

23. Aerial.
24. Range.
25. Supply of electrical energy.
26. Miscellaneous requirements.
27. Radiotelephone operators.
28. Radio watch by radiotelephone.
29. Watchkeeping.
30. Radiotelephone log.

PART IV—TECHNICAL REQUIREMENTS OF RADIO EQUIPMENT FOR  
LIFEBOATS

31. Motor lifeboats : fixed equipment.
32. Motor lifeboats : portable equipment.
33. Tests.

## PART V—RADIO DIRECTION-FINDERS

34. Application.
35. Provision of direction-finders.
36. Climatic and durability tests.
37. Interference.
38. High voltage parts.
39. Supply of electrical energy.
40. Charging of batteries.
41. Installation of direction-finder.
42. Means of communication.
43. Restriction on use.
44. Calibration.
45. Records of calibration and verification.
46. Wiring diagram and instructions.

FIRST SCHEDULE—Transitional provisions.

SECOND SCHEDULE—Radiotelegraph equipment.

THIRD SCHEDULE—Radiotelephone installation.

FOURTH SCHEDULE—Climatic and durability tests:

FIFTH SCHEDULE—Radiotelegraph equipment for lifeboats.

SIXTH SCHEDULE—Tools, measuring instruments, spare parts, etc.

SEVENTH SCHEDULE—Auto-alarm.

EIGHTH SCHEDULE—Table of watch hours.

NINTH SCHEDULE—Form of radiotelegraph log-book.

TENTH SCHEDULE—Form of radio telephone log-book.

ELEVENTH SCHEDULE—Direction-finder transitional provisions.

TWELFTH SCHEDULE—Direction-finding equipment.

THIRTEENTH SCHEDULE—Direction-finding equipment : Climatic and durability tests.

FOURTEENTH SCHEDULE—Certificate of calibration of direction-finder.

FIFTEENTH SCHEDULE—Record of check bearings of direction-finder.

L.N. 68<sub>a</sub> of 1964

MERCHANT SHIPPING ACT, 1962  
(1962, No. 30)

The Merchant Shipping (Radio and Direction-Finders) Rules, 1964

In exercise of the powers conferred by Sections 159 and 160 of the Merchant Shipping Act, 1962, the Federal Minister of Transport has made the following Rules—

Commencement : 11th June, 1964

PART I.—GENERAL

1. These Rules may be cited as the Merchant Shipping (Radio and Direction-Finders) Rules, 1964.

Citation and commencement.

2. Parts I to IV of these Rules shall apply to ships which are :—

Application. Parts I to IV.

- (a) sea-going Nigerian ships ; and  
(b) other sea-going ships while they are within any port in Nigeria ;  
but shall not apply to

- (i) ships not propelled by mechanical means ;  
(ii) pleasure yachts ;  
(iii) fishing boats ; or  
(iv) cargo ships of less than 300 tons.

3. In these Rules, unless the context otherwise requires, the following expressions shall have the meaning hereby respectively assigned to them, that is to say :—

Interpretation.

“The Act” means the Merchant Shipping Act, 1962.

“Cargo ship” means a ship other than a passenger ship ;

“Connected” means electrically connected ;

“Existing Installation” means :—

(a) an installation wholly installed before the date on which these Rules come into operation ; and

(b) an installation, part of which was installed before the said date, and the rest of which consists either of parts installed in replacement of identical parts, or parts which comply with the relative requirements of these Rules.

“Mile” means a nautical mile of 6,080 feet ;

“Operating Position” in relation to any equipment means the position normally occupied by a person when operating that equipment ;

“Radiotelegraph ship” means a ship, being a ship to which these Rules apply, which is provided with a radiotelegraph installation and which is not a radiotelephone ship ;

“Radiotelephone distress frequency” means, a frequency of 2182 kc/s ;

“Radiotelephone ship” means a cargo ship, being a ship to which these Rules apply, of not less than 300 tons, but of less than 1,600 tons the owner of which has given the Minister in writing (which has not been withdrawn) that the ship is provided with a radiotelephone in compliance with these Rules ;

“Radio watch” in the case of radiotelegraph ships, means listening on a frequency of 500 kc/s and in the case of radiotelephone ships means listening on the radiotelephone distress frequency ;

"Silence periods" means the periods of three minutes beginning for the purposes of radiotelegraphy at 15 minutes and at 45 minutes after each hour, and for the purposes of radiotelephony at each hour and at 30 minutes after each hour, in every case determined according to Greenwich Mean Time;

"Tons" means gross tons.

In relation to waves and signals:—  
 "Type A1" means radiotelegraphy by the keying of a continuous wave on and off;

"Type A2" means amplitude modulated radiotelegraphy by the keying of a modulating audio frequency or of an emission continuously modulated by an audio frequency; and

"Type A3" means double sideband amplitude modulated radiotelephony.

"Type B waves" means damped waves.

"Wireless operator" means a person who, holds a valid certificate of proficiency or competence in radiotelegraphy of the first or second class granted by the Postmaster-General of the United Kingdom, or by an authority empowered in that behalf by the laws of some part of the Commonwealth, and recognised by the Postmaster-General of the United Kingdom as the equivalent of such a certificate granted by him.

4. The ships to which these Rules apply shall be classified as follows—

CLASS I— Ships carrying more than 250 passengers or in respect of which there is in force a certificate issued by the Minister, or by any authority empowered on that behalf by the laws of any country other than Nigeria, to the effect that they are fit to carry more than 250 passengers, and which,  
 (a) in the case of a Nigerian ship registered in Nigeria, are at sea for more than 16 hours between two consecutive ports;

(b) in the case of other ships, arrive at a port in Nigeria having been at sea more than 16 hours since leaving the last port, or in respect of which clearance or transire is sought from a port in Nigeria for a voyage requiring more than 16 hours at sea before reaching port.

CLASS II— (a) Passenger ships other than those of Class I.

(b) Cargo ships of 1,600 tons and upwards.

CLASS III— Cargo ships of 300 tons and upwards but of less than 1,600 tons.

5.—(1) Every ship of Class I and Class II shall be provided with a radiotelegraph installation which shall include the equipment specified in the First and/or Second Schedules to these Rules.

(2) Every ship of Class III shall be provided with a radiotelephone installation which shall include the equipment specified in the Third Schedule to these Rules, or, with a radiotelegraph installation which shall include the equipment specified in the First and/or Second Schedules to these Rules. Provided that the main and emergency radiotelegraph transmitters in a ship of Class III may be combined in a single instrument, if that instrument is capable of complying with the requirements of Parts I and III of the said Second Schedule.

Classifica-  
tion of ships

Provision  
of radio  
installations.

6.—(1) All equipment the requirements for which are specified in these Rules shall be such that it will be free of mechanical defects and comply with the said requirements—

Climatic  
and  
Durability  
tests.

(a) while undergoing the vibration, dry heat, and low temperature tests specified in the Fourth Schedule to these Rules ;

(b) when subjected to the damp heat test specified in sub-paragraph (4) of paragraph 3 of the said Schedule ; and

(c) immediately after undergoing such of the other tests specified in the said Schedule as are applicable to the equipment in the circumstances.

(2) Any such equipment which is intended for use in the open or in an open boat shall be such that after undergoing the mould growth test specified in the Fourth Schedule to these Rules, no mould growth will be present on it.

7. At no time while the ship is at sea shall the interference or mechanical noise produced by the radio installation required by these Rules or by any other equipment in the ship be sufficient to prevent the efficient reception of radio signals by means of such installation.

Interference  
with  
reception.

8.—(1) All parts and wiring to which this Rule applies shall be protected from accidental access and, except in the case of a generator or convertor, shall be isolated automatically from all source of electrical energy when the means of protection are removed. Any such parts which are capacitors in a transmitter shall be capable of being discharged.

High  
Voltage  
parts.

(2) This Rule applies to all parts and wiring of the equipment specified in these Rules in which the direct and alternating voltages (other than radio frequency voltages) combine at any time to give an instantaneous voltage greater than—

(a) 50 volts in the case of equipment specified in the Fifth Schedule to these Rules ;

(b) 250 volts in the case of all other equipment.

9. Means shall be provided on board every ship to which these Rules apply for the charging from the ship's main source of electrical energy of any batteries which are provided as a source of electrical energy for any part of the equipment required by these Rules. An alternative means of charging such batteries shall also be provided if the means of charging such batteries is a rotary convertor.

Charging of  
batteries.

## PART II—RADIOTELEGRAPHY

10. Subject to the provisions of paragraph (2) of Rule 5 of these Rules, the main and emergency radiotelegraph equipments provided on board a radiotelegraph ship shall be electrically independent of each other.

Main and  
Emergency  
Equipment.

11.—(1) Every radiotelegraph installation provided on board a radiotelegraph ship shall be installed in one or more radiotelegraph rooms not used for any purpose other than the operation of radio equipment. The radiotelegraph rooms shall be in such a position that there will be no disturbance by extraneous noises or otherwise with the effective reception of radio signals.

Radio  
Telegraph  
Room.

(2) Every radiotelegraph installation provided on board a radiotelegraph ship shall be installed in such a position that it will be protected against disturbance of its effectiveness by water or by extremes of temperature.

(3) Every radiotelegraph room shall be provided with—

(a) an efficient two-way means of calling and voice communication with the bridge and any other place from which the ship is normally navigated. Such means of communication shall be a voicepipe or a telephone, or some other equally efficient means and shall be independent of the main communication system of the ship and of the ship's main source of electrical energy ;

(b) a reliable clock, equipped with a dial not less than 5 inches in diameter and a centre seconds hand, securely mounted in such a position that the entire dial can be easily and accurately observed from the radiotelegraph operating position and, if the ship is provided with an auto-alarm, from the position normally occupied by a person testing the auto-alarm ;

(c) an electric lamp, operated from the source of electrical energy required by paragraph (2) of Rule 14 of these Rules and permanently arranged so as to be capable of providing adequate illumination of the operating controls of the main and emergency radiotelegraph installations and of the clock required by this Rule, and controlled by two-way switches placed respectively near the entrance to the radiotelegraph room and at the radiotelegraph operating position ;

(d) an additional electric lamp, for use as an inspection lamp, operated from the aforesaid source of energy, and provided with a flexible lead of sufficient length to enable all parts of the radiotelegraph installation to be easily seen ;

(e) a chair capable of being fixed at the radiotelegraph operating position.

(4) A complete list of spare equipment and spare parts carried on board the ship for the maintenance of the radiotelegraph installation, shall be available in every radiotelegraph room and shall indicate where such equipment and parts are kept.

(5) A calibration table or calibration curve for each transmitter and receiver forming part of the radiotelegraph installation shall always be available in the radiotelegraph room, unless the transmitter or receiver, as the case may be, is directly calibrated.

(6) In the case of a radiotelegraph installation which is not an existing installation, a complete diagram of the wiring of such installation shall always be available in a radio-telegraph room.

Aerials.

12.—(1) Every radiotelegraph ship shall be fitted with a main aerial and an emergency aerial; provided that the Minister may exempt any ship from the requirement of an emergency aerial if he is satisfied that the fitting of such an aerial is impracticable or unreasonable in the circumstances. Any ship so exempted shall carry a spare aerial completely assembled for immediate erection.

(2) Each of the halyards used for supporting such main aerial shall be fitted with a safety loop between the masthead or other aerial support and an aerial insulator. Such safety loop shall consist of a part of the halyard not less than three feet long, the loop being closed by a link not more than one foot three inches long with a breaking load not more than one-third of the breaking load of the aerial or the halyard, whichever is the less.

(3) A rigging plan of such aerials shall be available in a radiotelegraph room, and shall show the following—

- (a) elevation and plan views of the aerials ;
- (b) the measurements of the aerials in feet and inches ; and
- (c) the height of the aerials in metres measured in the manner specified in paragraph (3) of Rule 13 of these Rules.

(4) The main aerial and the emergency aerial (if any) shall, where practicable, be so rigged that damage to the one will not affect the efficiency of the other.

(5) The main and emergency aerials shall each be capable of being connected, as circumstances may require, to

- (a) the main transmitter, either directly or with the intervention of an amplifier ;
- (b) the main receiver ; and
- (c) the emergency transmitter.

The emergency aerial shall also be capable of being connected to the emergency receiver.

13.—(1) The normal ranges of the radiotelegraph transmitters provided in accordance with the foregoing provisions of these Rules shall not be less than—

Range of transmitters.

(a) in the case of a ship of Class I, 175 miles for the main transmitter and 150 miles for the emergency transmitter ;

(b) in the case of a ship of Class II, 150 miles for the main transmitter and 100 miles for the emergency transmitter ;

(c) in the case of a ship of Class III, 100 miles for the main transmitter and 75 miles for the emergency transmitter.

(2) The range of a transmitter for the purposes of these Rules shall be determined, at the option of the owner of the ship, either by reckoning or by test.

(3) For the purposes of these Rules the normal range of a radiotelegraph transmitter when determined by reckoning, shall be calculated by ascertaining the product of the root mean square current in amperes at the base of the main aerial and the maximum height in metres of the aerial measured from the level and the maximum depth to which the ship may at any load line mark indicating the greatest depth in accordance with the Merchant Shipping time or place be submerged in accordance with the Merchant Shipping (Load Line) Rules or, if there is no such mark on the ship, from the mean level of the surface of the water in which the ship is afloat. The product so ascertained in metre-amperes shall be converted to miles in accordance with the following table—

<i>Product in Metre-amperes</i>	<i>Equivalent in miles</i>
102	175
76	150
45	100
34	75
10	25

(4) For the purposes of these Rules the normal range of a radiotelegraph transmitter, when determined by test, shall be the distance to which signals can be transmitted by such transmitter over the sea by day under normal conditions on a frequency of 500 kc/s. so as to set up at the receiver a total root mean square field strength of at least 50 microvolts per metre.

Supply of electrical energy.

14.—(1) There shall be available in every radiotelegraph ship while the ship is at sea, and at all reasonable times when the ship is in port for testing purposes, a supply of electrical energy from the ship's main source of electrical energy sufficient for the operation of the main radiotelegraph equipment in accordance with these Rules, and for the charging of any batteries which are a source of electrical energy for the radiotelegraph installation. The rated voltage of the supply of electrical energy for the main equipment shall be maintained within plus or minus 10 per cent. The supply of electrical energy shall, if it is a direct current supply, be of correct polarity. Provided that in any ship not engaged on an international voyage the aforesaid supply of electrical energy may be derived from a battery, in which case a duplicate battery shall also be provided for that purpose.

(2) The emergency equipment shall include a source of electrical energy independent of the propelling power of the ship and of the rest of the ship's electrical installation, and shall be capable of being brought into immediate operation by means of a switchboard situated in a radiotelegraph room or readily accessible therefrom. Any source of electrical energy provided in compliance with this paragraph shall be of such capacity and shall be maintained at all times when at sea in such a condition as to be able to supply continuously for a period of 6 hours, whether or not it is in use for any other purpose, a total current equal to the sum of—

(a) the current required to operate the emergency transmitter with the key up ;

(b) three-fifths of the difference between the current required to operate the emergency transmitter with the key down and the current required to operate it with the key up ;

(c) the current required to operate the emergency receiver ; and

(d) the current consumed by the electric lamp required by paragraph (3) (c) of Rule 11 of these Rules.

(3) The source of electrical energy provided under paragraph (2) of this Rule shall not be used at any time except for the operation of—

(a) the emergency transmitter and receiver ;

(b) the lamps required by paragraph (3) (c) and (d) of Rule 11 of these Rules ;

(c) the automatic keying device ;

(d) an auto-alarm ;

(e) a direction-finder.

15. Every radiotelegraph ship shall be provided with the tools, measuring instruments, spare parts and other material specified in the Sixth Schedule to these Rules.

16. The Government Inspector of Shipping may exempt any ship of Class III from any of the requirements of the foregoing provisions of this Part of these Rules, subject to such conditions as he thinks fit.

Tools, etc. Sixth Schedule.

Exemption Class III ships.

17.—(1) Every radiotelegraph ship which upon proceeding to sea is not provided with an auto-alarm complying with the requirements specified in the Seventh Schedule to these Rules shall be provided with radio officers as follows—

Provision  
of radio  
officers.  
Seventh  
Schedule.

CLASS I—three radio officers.

CLASS II—two radio officers if she is at sea for not more than 48 hours between consecutive ports, and three radio officers if she is at sea for more than 48 hours between consecutive ports.

CLASS III—one radio officer.

(2) Every radiotelegraph ship which upon proceeding to sea is provided with an auto-alarm complying with the aforesaid requirements shall be provided with radio officers as follows—

CLASS I—two radio officers.

CLASS II—one radio officer.

CLASS III—one radio officer.

18.—(1) For the purposes of these Rules no person shall be qualified to be a radio officer on board a Nigerian ship unless he holds a valid certificate of proficiency or competence in radiotelegraphy of the first or second class granted by the Postmaster-General in the United Kingdom, or its equivalent granted by a competent authority empowered to do so in any Commonwealth country. In the case of at least one of the radio officers on board a Nigerian passenger ship, such certificate shall be a certificate of the first class.

Qualifi-  
cations of  
radio officers.

(2) For the purposes of paragraph (1) of this Rule no certificate of proficiency or competence shall be deemed to be valid at any date if it was granted more than two years before that date and either

(a) the holder's periods of experience do not total three months, or

(b) the holder's last experience was more than 2 years before that date

unless the holder satisfies the issuing authority by re-examination or otherwise that he still possesses all of the qualifications described in his certificate. For the purposes of this paragraph the expression "experience" means experience at sea as a radio officer or wireless operator or experience as an operator of radiotelegraph apparatus at a radiotelegraph station maintained on land for communication with ships.

(3) At least one of the radio officers on board a Nigerian ship of Class I or Class II shall be a person who has had experience at sea as a radio officer or wireless operator for a total of not less than—

(a) two years in the case of ships of Class I ;

(b) one year in the case of ships of Class II (a) ;

(c) six months in the case of ships of Class II (b), being ships of 3,000 tons or upwards ;

(d) three months in the case of ships of Class II (b), being ships of 1,600 tons and upwards but under 3,000 tons,

(4) For the purposes of these Rules no person shall be deemed to be a radio officer on board a ship not registered in Nigeria unless he holds a valid certificate of proficiency or competence in radiotelegraphy granted by

Radio  
watch by  
radiotele-  
graph.

an authority empowered or recognised in that behalf by the laws of the country in which the ship is registered and recognised by the Minister as the equivalent of such a certificate issued by the competent authorities in the Commonwealth.

19.—(1) Subject to the provisions of paragraph (1) of Rule 20 radio watch shall be maintained at sea on board every radiotelegraph ship by a radio officer as follows—

(a) if the ship upon proceeding to sea is not provided with an auto-alarm complying with the requirements specified in the Seventh Schedule to these Rules :—

(i) in the case of a ship of Class I or Class II a continuous watch ;

(ii) in the case of a ship of Class III a watch of eight hours per day at the times specified in column 5 of the Eighth Schedule to these Rules in relation to the zone in which the ship then is ;

(b) if the ship upon proceeding to sea is provided with an auto-alarm as aforesaid :—

(i) in the case of a ship of Class I a watch of sixteen hours per day at the times specified in column 4 of the Eighth Schedule to these Rules in relation to the zone in which the ship then is ;

(ii) in the case of a ship of Class II or Class III a watch of eight hours per day at the times specified in column 5 of the Eighth Schedule to these Rules in relation to the zone in which the ship then is.

(2) Any auto-alarm provided on board a radiotelegraph ship shall be in operation at all times at which a radio watch is not maintained unless the auto-alarm has broken down since the ship last put to sea and cannot be repaired at sea so as to operate effectively.

20.—(1) Every radio officer on board a radiotelegraph ship shall keep radio watch by means of headphone reception throughout his period of duty except when another radio officer keeps radio watch by headphone reception. Provided that—

(a) radio watch may be maintained by means of loud-speaker reception, or  
(b) if loud-speaker reception is impracticable radio watch may be dispensed with except during a silence period,

for such periods as may be necessary to enable the radio officer to perform other duties in compliance with these Rules.

(2) Every radio officer on board a radiotelegraph ship provided with an auto-alarm complying with the requirements aforesaid shall, whenever radio watch ceases to be maintained during or at the end of his period of duty, connect the auto-alarm with the ship's main aerial, or with any other equally efficient aerial, and shall put the auto-alarm into operation. Every radio officer who leaves an auto-alarm in operation when he goes off duty shall before going off duty—

(a) test the efficiency of the auto-alarm ; and

(b) immediately report the result of such test to the master of the ship or to the officer in charge of the navigation of the ship.

(3) Every such radio officer who finds an auto-alarm connected to an aerial when he goes on duty shall immediately test the efficiency of the auto-alarm before making any adjustment thereto.

Watch-  
keeping.

(4) While a radiotelegraph ship is at sea, the radio officer, or if there is more than one, the first radio officer, shall cause the following tests to be made—

(a) a test once a day of the emergency radiotelegraph transmitter connected with an artificial aerial complying with the requirements specified in paragraph 13 of Part III of the Second Schedule to these Rules ;

(b) if the ship is engaged on an international voyage a test during every voyage of the emergency radiotelegraph transmitter connected with the emergency aerial, if any ;

(c) a test once a day by voltmeter and once a month by hydrometer of any batteries which are a source of energy for the radiotelegraph installation ;

(d) a test once a day of any other source of electrical energy provided for the emergency radiotelegraph equipment ; and

(e) a test once a day of the audible alarm circuits and of the bells forming part of the auto-alarm.

(5) While a radiotelegraph ship is at sea, the radio officer, or if there is more than one, the first radio officer, shall take all steps within his power to cause the equipment referred to in these Rules to be properly maintained and when necessary to be repaired and adjusted. Such officer shall cause all batteries, being a source of electrical energy for any part of the radiotelegraph installation, which are found not to be fully charged to be brought up to that condition as soon as may be.

21. The transmitter forming part of the emergency radiotelegraph equipment shall not be used to transmit messages other than those relating to the safety of life at sea, unless such transmitter complies with the requirements specified in Part I of the Second Schedule to these Rules.

Uses of  
emergency  
transmitter

22.—(1) A radiotelegraph log-book in the form specified in the Ninth Schedule hereto shall be kept in a radiotelegraph room on board every Nigerian Radiotelegraph ship, and shall be available for inspection by any person authorised in that behalf by the Minister.

Radio Log

(2) Every radio officer on board such a ship shall, when on duty, enter in such log-book—

(a) his name ;

(b) the times at which he goes on and off duty ;

(c) the identifying number of each message transmitted by him or received by him, together with the time and date of such transmission or reception, the station to which each message is transmitted by him and the station from which each message is received by him ; and

(d) a record of all incidents occurring during his period of duty which relate to the radiotelegraph installation and the operation thereof and which appear to him to be of importance to the safety of life at sea ; in particular, he shall make the following entries—

(i) the full text of all the messages transmitted by him or received by him which relate to immediate assistance required by persons in distress at sea or above the sea ;

(ii) the full text of all messages transmitted by him or received by him which are preceded by a signal in general international use as an urgency signal or a safety signal ;

(iii) a record of the radio watch maintained by him during each of the silence periods ;

(iv) a record of any incident occurring during his period of duty which affects the efficiency of the radiotelegraph installation ;

(v) a record of the tests conducted by him in accordance with paragraphs (2), (3) and (4) of Rule 20 of these Rules, and of the results of such tests ;

(vi) a record of the charging by him of any batteries used as a source of energy for the radiotelegraph installation ; and

(vii) if the ship is provided with an auto-alarm, details of any failure or repair thereof during his period of duty.

(3) The radio officer, or if there is more than one, the first radio officer, shall cause an entry to be made in such log-book at least once a day recording the time shown by the clock in each radiotelegraph room in comparison with Greenwich Mean Time, and any correction made in respect of that clock.

(4) The master of the ship and, if there is more than one radio officer, the first radio officer, shall inspect and sign such log-book once a day.

(5) Sections 134, 135 and 138 of the Act shall apply to radiotelegraph log-books as they apply to official log-books.

Aerial.

#### PART III.—RADIOTELEPHONY

23. Every radiotelephone ship shall be fitted with an aerial, and in addition shall carry a spare aerial completely assembled for immediate erection. A rigging plan of the fitted aerial shall be available on board and shall show—

(i) elevation and plan views of the aerial ;

(ii) the measurements of the aerial in feet and inches ; and

(iii) the height of the aerial in metres measured in the manner specified in paragraph (3) of Rule 24 of these Rules.

Range.

24.—(1) The normal range of the radiotelephone transmitter provided in accordance with the foregoing provisions of these Rules shall not be less than 150 miles.

(2) The range of a radiotelephone transmitter for the purposes of these Rules shall be determined at the option of the Owner of the ship either by reckoning or test.

(3) For the purposes of these Rules the normal range of a radiotelephone transmitter, when determined by reckoning on the radiotelephone distress frequency, shall be calculated by ascertaining the product of the root mean square current in amperes at the base of the aerial and the maximum height in metres of the aerial measured from the lead-out insulator. The transmitter shall be deemed to comply with the requirements of this Rule if the product so ascertained is not less than—

(a) 9.6 metre-amperes on a frequency of 1,650 kc/s. or 7.5 metre-amperes on a frequency of 2,182 kc/s. in either case if the aerial has a horizontal top-length of not less than one-half of its maximum height measured from the lead-out insulator ;

(b) 14.7 metre-amperes on a frequency of 1,650 kc/s. or 12.8 metre-amperes on a frequency of 2,182 kc/s. in the case of any other aerial.

(4) For the purposes of these Rules, the normal range of a radiotelephone transmitter, when determined by test on the radiotelephone distress frequency, shall be the distance to which signals can be transmitted by such transmitter

over the sea by day under normal conditions on that frequency so as to set up at the receiver by the unmodulated carrier a total root mean square field strength of at least 25 microvolts per metre.

25.—(1) There shall be available in every radiotelephone ship while she is at sea a supply of electrical energy sufficient to operate the radiotelephone installation in accordance with these Rules. The supply of electrical energy shall, if it is a direct current supply, be of correct polarity. In the case of a radiotelephone installation which is not an existing installation an emergency source of electrical energy shall be provided in the upper part of the ship unless the main source is so situated. Each source of energy provided in accordance with this Rule shall be of such capacity as to be able to supply continuously for a period of six hours a total current equal to the sum of—

Supply of  
Electrical  
Energy.

(a) one-half of the current required to operate the radiotelephone transmitter for the transmission of speech ;

(b) the current required to operate the radiotelephone receiver ; and

(c) the current consumed by the electrical lamp required by paragraph (d) of Rule 26 of these Rules.

(2) If a single battery is provided for the foregoing purpose means shall also be provided for either—

(a) operating the radiotelephone receiver and transmitter from the ship's main source of electrical energy ; or

(b) float-charging the battery while it is in use, in which case there shall be adequate protection against voltage rise.

Such means shall be so designed as not to require the earthing of the ship's main source of electrical energy, and a filter shall be provided to prevent main borne interference from entering the receiver.

(3) When the batteries for the radiotelephone transmitter are not in use, each battery shall be capable of being fully charged within a period of not more than 16 hours by the means for charging required by Rule 9 of these Rules.

26. The following provisions shall apply to every radiotelephone ship—

(a) An efficient two-way means of communication shall be provided between the place where the aforesaid radiotelephone installation is installed and any other place from which the ship is normally navigated.

(b) The radiotelephone installation required by these Rules shall be installed as high as practicable in the ship.

(c) A reliable clock shall be securely mounted within sight of the operating position ; and

(d) An electric lamp shall be provided and shall be operated from the emergency source of electrical energy required by Rule 25 of these Rules or, if no emergency source of electrical energy is so required, from the main source. The lamp shall be permanently arranged so as to be capable of providing adequate illumination of the operating controls of the radiotelephone installation and the clock required by sub-paragraph (c) of this Rule. The lamp shall be controlled by two-way switches placed respectively near an entrance to the room in which the radiotelephone installation is installed and at the operating position thereof in that room.

Miscellaneous  
requirements.

Radio-tele-  
phone opera-  
tors.

27.—(1) Every radiotelephone ship shall be provided with at least one radiotelephone operator.

(2) For the purposes of these Rules no person shall be qualified to be a radiotelephone operator on board a Nigerian ship unless he holds a valid certificate of proficiency or competency in radiotelephony or radiotelegraphy granted by the Postmaster-General, of the United Kingdom or by an authority empowered in that behalf by the laws of some part of the Commonwealth, and recognised by the Postmaster-General of the United Kingdom as the equivalent of such a certificate granted by him.

(3) For the purpose of these Rules no person shall be deemed to be a radiotelephone operator on board a ship registered in a country other than Nigeria unless he holds a valid certificate of proficiency or competency in radiotelephony or radiotelegraphy granted by an authority empowered or recognised in that behalf by the laws of the country in which the ship is registered and recognised by the Minister as the equivalent of such a certificate issued by the competent authorities in the Commonwealth.

28. While a radiotelephone ship is at sea radio watch shall be maintained by a radiotelephone operator for at least 8 hours a day, at the times specified in Column 5 of the Eighth Schedule of these Rules in relation to the zone in which the ship then is.

29.—(1) Every radiotelephone operator on board a radiotelephone ship shall keep radio watch during the periods of duty assigned to him by the master of the ship.

(2) While a radiotelephone ship is at sea, the radiotelephone operator, or if there is more than one, the first radiotelephone operators, shall cause any batteries which are a source of electrical energy for the radiotelephone installation to be tested once a day and brought up to the fully-charged condition as soon as may be.

30.—(1) A radiotelephone log-book in the form specified in the Tenth Schedule hereto shall be kept near the radiotelephone installation in every radiotelephone ship, and shall be available for inspection by any person authorised in that behalf by the Minister.

(2) Paragraphs (2), (3), (4) and (5) of Rule 22 shall apply to such radiotelephone log-book as they apply to a radiotelegraph log-book, and references in the said paragraphs to a radio officer, a radiotelegraph installation and a radiotelegraph room shall be construed accordingly. Provided that an entry shall be required to be made in the radiotelephone log-book only of the general sense of the messages referred to in sub-paragraph (d) of paragraph (2) of that Rule.

#### PART IV.—TECHNICAL REQUIREMENTS OF RADIO EQUIPMENT FOR LIFEBOATS

31.—(1) The radiotelegraph equipment required by Rule 29 of the Merchant Shipping (Lifesaving Appliances) Rules, 1963, shall comply with the specifications set forth in Part I of the Fifth Schedule hereto.

(2) The battery included in such equipment shall not be used for any purpose other than the operation of such equipment and of the searchlight provided in compliance with the aforesaid Rules.

32. The equipment required by paragraph (10) of Rule 6 and paragraph (10) of Rule 7 of the Merchant Shipping (Lifesaving Appliances) Rules, 1963, shall comply with the specifications set forth in Part II of the Fifth Schedule hereto.

Radio watch  
by radio-  
telephone.Watch  
keeping.Radio-  
telephone  
log.Motor  
lifeboats.  
Fixed  
equipment.Motor  
lifeboats.  
Portable  
equipment.

33.—(1) When a radiotelegraph ship provided with the equipment referred to in Rule 31 or Rule 32 of these Rules is at sea the radio officer, or if there is more than one, the first radio officer, shall at least once every 7 days cause the transmitter forming part of such installation or equipment to be tested with its artificial aerial and cause any batteries, other than self-priming batteries, which are a source of electrical energy for such installation or equipment to be tested by voltmeter and hydrometer and brought up to fully-charged condition as soon as may be.

Tests.

(2) The radio officer making the tests referred to in paragraph (1) of this Rule shall cause the results of such tests to be entered in the radiotelegraph log-book.

#### PART V.—RADIO DIRECTION-FINDERS

34. This Part of these Rules shall apply to ships which are—
- Application.
- (a) sea-going Nigerian ships of 1,600 tons and upwards ;
- (b) other sea-going ships of 1,600 tons and upwards while they are within any port in Nigeria,
- but they shall not apply to :—
- (i) ships not propelled by mechanical means ;
- (ii) pleasure yachts ;
- (iii) fishing boats, or
- (iv) any ship not engaged on an international voyage.
35. Every ship to which this Part applies shall be provided with a direction-finder, complying with the requirements specified in the Twelfth Schedule hereto.
- Provision of direction-finders.
- 36.—(1) The direction-finder required by this Part shall be such that it will be free from mechanical defects and will comply with the requirements of this Part—
- Climatic and durability tests.
- (a) while undergoing the vibration, dry heat, and low temperature tests specified in the Thirteenth Schedule to these Rules ;
- (b) when subjected to the damp heat test specified in the said Schedule ; and
- (c) immediately after undergoing the other tests specified in the said Schedule.
- (2) The loop aerial system referred to in the Twelfth Schedule to these Rules shall be such that after undergoing the mould growth tests specified in the Thirteenth Schedule to these Rules no mould growth will be present on it.
37. At no time when the ship is at sea shall interference or mechanical noise produced by the direction-finder required by this Part or by any other equipment in the ship be sufficient to prevent the efficient determination of radio bearings by means of the direction-finder.
- Interference.
38. All parts and wiring of the equipment specified in this Part in which the direct and alternating voltages (other than radio frequency voltages) combine at any time to give an instantaneous voltage greater than 250 volts shall be protected from accidental access and, except in the case of a generator or converter, shall be isolated automatically from all sources of electrical energy when the means of protection are removed.
- High voltage parts.

Supply of electrical energy.

Charging of batteries.

Installation of direction finder.

Means of communication.

Restriction on use.

Calibration.

39. There shall be available in every ship to which this Part applies, whenever she is at sea, a supply of electrical energy sufficient for the operation of the direction-finder. When the ship is in port such supply shall also be available for testing purposes at all reasonable times.

40. Equipment shall be provided on board every ship to which this Part applies for the charging of any batteries which are provided as a source of electrical energy for the direction-finder, and the ship's main source of electrical energy shall always be available for charging the batteries when the ship is at sea. The master of the ship shall cause such batteries to be tested once a day by voltmeter and once a month by hydrometer, and shall cause any battery which is found not to be fully charged to be brought up to that condition as soon as may be.

41.—(1) The direction-finder shall be installed in such a position that efficient determination of radio bearing by means of the direction-finder will not be hindered by extraneous noises.

(2) The loop aerial system referred to in the Twelfth Schedule hereto shall be mounted so that the efficient determination of radio bearing by means of the direction-finder shall be hindered as little as possible by the proximity of aerials, derricks, wire halyards and other large metal objects.

(3) Unless the feeder cables connecting the loop aerial system with the receiver forming part of the direction-finder consist of solid-dielectric screened cable, they shall be protected by metal tubes which are bonded to earth. The joints of the feeder cables shall be watertight.

42.—(1) In every ship to which this Part applies an efficient two-way means of calling and voice communication shall be provided between the receiver forming part of the direction-finder and the bridge from which the ship is normally navigated.

(2) In every such ship an efficient means of signalling shall be provided between the receiver forming part of the direction-finder and the ship's standard compass or gyro compass repeater, if any.

43. The direction-finder required by this Part shall not be used—

(a) for any purpose other than the business of the ship; or

(b) for keeping the radio watch required by Rule 19 of these Rules.

44.—(1) The Master of every ship to which this Part applies shall cause the direction-finder required by this Part to be calibrated in accordance with this Rule by two persons, the one experienced in the taking of radio bearings and the other experienced in taking visual bearings.

(2) The direction-finder shall be so calibrated as soon as may be after it has been installed in the ship and whenever any change is made in the position of the loop aerial system.

(3) The direction-finder shall be calibrated in the following manner—

(a) The calibration of the direction-finder shall be carried out by taking simultaneously visual bearings upon a calibrating transmitter and radio bearings thereon by means of the direction-finder, the ship being either,

(i) swung through a complete circle; or

(ii) circled by another ship carrying the calibrating transmitter, and in either case the bearings being taken throughout 360° at intervals of 5 degrees or as close thereto as may be. The calibrating transmitter upon

which the bearings are taken, whether it is situated on shore or on board another ship, shall be a transmitter operating on a frequency between 285 kc/s and 315 kc/s.

(b) Calibration tables and curves shall be prepared on the basis of the bearings taken in accordance with sub-paragraph (a) of this paragraph.

(4) The master of the ship shall cause the calibration tables and curves prepared in accordance with the foregoing provisions of this Rule to be verified by means of check-bearings taken in the manner therein specified.—

(a) at intervals not exceeding twelve months ; and

(b) whenever any change is made in any structure or fitting on deck which is likely to affect the accuracy.

If such verification shall show that the calibration tables or curves are materially inaccurate the master of the ship shall cause the direction-finder to be re-calibrated as soon as may be in the manner specified in the foregoing provision of this Rule.

45. The master of every ship to which this Part applies shall cause the following records to be kept on board in a place accessible to any person operating the direction-finder, and to be available for inspection at any reasonable time by a Surveyor of Ships :—

Records of  
calibration  
and  
verification.

(a) a list or diagram indicating the conditions and position, on the most recent occasion on which the direction-finder was calibrated, of—

(i) the aerials, and of

(ii) all moveable structures,

on board the ship which might affect the accuracy of the direction-finder ;

(b) the calibration tables and curves which were prepared on the most recent occasion on which the direction-finder was calibrated ;

(c) a certificate of calibration, in the form specified in the Fourteenth Schedule hereto, relating to the most recent occasion on which the direction-finder was calibrated, and signed by the persons making the calibration ; and

(d) a record, in the form specified in the Fifteenth Schedule hereto, of check-bearings taken for the verification of calibration, the bearings being numbered in the order in which they were taken.

46. A schematic wiring diagram of the direction-finder and a book containing adequate instructions as to the use of the direction-finder shall be provided and shall be available at all times for use by any person operating or testing the direction-finder.

Wiring  
diagram  
and  
instructions.

## FIRST SCHEDULE

1. As To Rule 5.—Subject to the provisions of paragraph 2 of this Schedule any ship which is provided with radiotelegraph equipment forming part of an existing installation which had been installed before 19th November, 1954, shall not be required to be provided with the equipment specified in the Second Schedule to these Rules if the radiotelegraph equipment provided in the ship complies with :—

(i) such of the requirements of the United Kingdom Merchant Shipping (Wireless Telegraphy) Rules, 1938, as would have been applicable to it if the said Rules had not been revoked, and

(ii) with the requirements set forth in the following table :—

<i>Item</i>	<i>Requirement</i>
(1) The main transmitter and main receiver.	Must together be capable of changing automatically from transmission to reception in the intervals between the morse signals of any transmission.
(2) Main and emergency transmitter.	Must each be modulated to a depth of not less than 70 per cent.
(3) Main transmitter.	Must be capable of :— (a) transmitting type A2 waves on frequencies of either, (i) 410 kc/s, 500 kc/s and 512 kc/s and on any two of the frequencies 425 kc/s, 454 kc/s, 468 kc/s and 480 kc/s ; or (ii) in any case in which the Minister so permits 410 kc/s, 500 kc/s and on one of the frequencies 425 kc/s, 454 kc/s, 480 kc/s and 512 kc/s. (b) maintaining throughout the period of 10 minutes from the commencement of transmission a frequency tolerance not exceeding plus or minus 0.3 per cent ; and (c) maintaining throughout every transmission a frequency tolerance not exceeding plus or minus 0.1 per cent.
(4) Emergency transmitter.	Must be capable of :— (a) transmitting type A2 waves on a frequency of 500 kc/s ; (b) maintaining a frequency tolerance throughout every transmission not exceeding plus or minus 0.5 per cent subject to the provisions of paragraph 15 of this Schedule.
(5) Main receiver	(a) Must be capable of :— (i) producing signals in head phones when the receiver input is as low as 100 microvolts. (ii) receiving type A1 waves on all frequencies from 15 kc/s to 20 kc/s and from 100 kc/s to 160 kc/s ; and

- (iii) receiving type A1 and A2 waves on all frequencies either :—
- (i) from 160 kc/s to 25,000 kc/s or
  - (ii) in cases in which the Minister so permits, from 160 kc/s to 4,000 kc/s.
- (b) Must be such that the radiation from the receiver does not exceed 0.1 microvolt per metre when measured at a distance of one mile from the receiver or when tested in the manner set forth in sub-paragraph (2) of paragraph 16 of Part II of the Second Schedule to these Rules.
- (6) Emergency receiver
- (a) Must be capable of :—
    - (i) producing signals by means of a loud-speaker when the receiver input is as low as 100 microvolts ;
    - (ii) receiving type A2 and type B waves on a frequency of 500 kc/s,
  - (b) Must be such that the radiation from the receiver does not exceed 0.1 microvolt per metre when measured at a distance of one mile from the receiver, or when tested in the manner set forth in sub-paragraph (2) of paragraph 15 of Part IV of the Second Schedule to these Rules.
- (1) Transmitter (a) Must be capable of :—
- (i) transmitting type A3 waves on the radiotelephone distress frequency and at least 4 other frequencies within the band 1,600 kc/s to 2,850 kc/s ;
  - (ii) maintaining throughout the period of 10 minutes from the commencement of transmission a frequency tolerance not exceeding plus or minus 0.05 per cent ; and
  - (iii) maintaining throughout every transmission a frequency tolerance not exceeding plus or minus 0.02 per cent.
- (b) Must be modulated to a depth of not less than 70 per cent at peak intensity in normal operation.
- (2) Receiver (a) Must be capable of :—
- (i) receiving type A3 waves on all frequencies from 1,600 kc/s to 2,850 kc/s.
  - (ii) producing signals both in head-phones and by means of a loud-speaker when the receiver input does not exceed 50 microvolts ; and
  - (b) Must be such that radiation from the receiver does not exceed 0.1 microvolt per metre when measured at a distance of one mile from the receiver or when tested in the manner set forth in sub-paragraph (14) (b) of paragraph 6 of the Third Schedule to these Rules.

4. AS TO RULE 6.—Nothing in Rule 6 of these Rules shall apply to equipment which is part of an existing installation, or to equipment, being equipment referred to in paragraph 1 or paragraph 4 of this Schedule, which had been installed before 19th November, 1954.

5. AS TO RULE 8.—Nothing in paragraph (1) of Rule 8 of these Rules shall require any parts or wiring in an existing installation to be isolated automatically from all sources of electrical energy when the means of protection referred to therein are removed.

6. AS TO RULE 6, RULE 17 AND RULE 19.—Nothing in Rule 6, Rule 17 or Rule 19 of these Rules shall apply to any auto-alarm which complies with such of the requirements of the United Kingdom Merchant Shipping (Wireless Telegraphy) Rules, 1938, as would have been applicable to it if the said Rule had not been revoked. Provided that the radiation from the auto-alarm receiver shall not exceed 0.1 microvolt per metre when measured at a distance of one mile from the auto-alarm, or when tested in the manner set forth in sub-paragraph (10) (a) of paragraph 2 of the Seventh Schedule to these Rules.

7. AS TO RULE 31.—

(a) Any existing radiotelegraph installation in a motor lifeboat, and

(b) Any radiotelegraph installation installed in a motor lifeboat before 19th November, 1954,

which complies with such of the requirements of the United Kingdom Merchant Shipping (Life Saving Appliances) Rules, 1948, as would have been applicable to it if the said Rules had not been revoked shall be treated as complying with the requirements specified in Part I of the Fifth Schedule to these Rules if it includes the equipment specified in the following subparagraphs:—

(1) A copper earth connection, connected by at least three independent bolted connections to the hull in the case of a metal lifeboat or to a bare copper earthplate of area at least six square feet fitted below the water line in the case of a wooden lifeboat.

(2) A transmitter which is:—

(a) modulated to a depth of not less than 70 per cent ;

(b) capable of:—

(i) transmitting either type A2 or type B waves on a frequency of 500 kc/s ;

(ii) transmitting type A2 waves on a frequency of 500 kc/s ;

(iii) maintaining throughout every transmission on that frequency a frequency tolerance not exceeding plus or minus 0.5 per cent ;

(iv) transmitting over a normal range of 25 miles determined in the manner prescribed by Rule 13 of these Rules ;

(v) transmitting the alarm signal and the distress signal by means of an automatic keying device ; and

(c) if installed on or after 19th November, 1953 is capable of:—

(i) transmitting type A2 waves on a frequency of 8,364 kc/s, and

(ii) maintaining throughout every transmission on that frequency a frequency tolerance not exceeding plus or minus 0.02 per cent.

8. AS TO RULE 32.—Any portable radiotelegraph equipment for lifeboats provided before 19th November, 1953, in a ship to which these Rules apply which complies with such of the requirements of the United Kingdom Merchant Shipping (Life-Saving Appliances) Rules, 1948, as would have been applicable to it if the said Rules had not been revoked shall be treated as complying with the requirements specified in Part II of the Fifth Schedule to these Rules if the transmitter forming part of such equipment complies with the requirements specified in the following sub-paragraphs.—

the transmitter shall :—

- (a) be modulated to a depth of not less than 70 per cent ;
- (b) have an input of at least 10 watts to the anode of the final stage ;
- (c) be capable of :—
  - (i) transmitting type A2 waves on a frequency of 500 kc/s ;
  - (ii) maintaining throughout every transmission a frequency tolerance not exceeding plus or minus 0.5 per cent and
  - (iii) transmitting the alarm signal and distress signal by means of an automatic keying device.

## SECOND SCHEDULE (Rule 5 (1) )

### RADIOTELEGRAPH EQUIPMENT

#### PART I.—MAIN RADIOTELEGRAPH TRANSMITTER

1. GENERAL.—The main radiotelegraph transmitter (in this Part of this Schedule referred to as "the transmitter") shall be provided with any equipment which may be necessary to enable it to be operated from the supply of energy referred to in paragraph (1) of Rule 14 of these Rules, and shall be capable of being quickly connected with the main and emergency aerials referred to in Rule 12 of these Rules.

2. TYPES OF WAVES AND FREQUENCY RANGE.—The transmitter shall be capable of adjustment for the transmission of both type A1 and A2 waves as may be required in the frequency range 405 kc/s to 525 kc/s.

3. TRANSMITTING FREQUENCIES.—The transmitter shall be capable of transmitting continuously but not simultaneously, radiotelegraph signals on the frequencies of 500 kc/s, 410 kc/s and 512 kc/s and on two of the following frequencies :—

425 kc/s, 454 kc/s, 468 kc/s and 480 kc/s.

4. RANGE OF LOAD IMPEDANCE.—The transmitter shall be capable of complying with all the requirements of this Part of this Schedule when connected to an artificial load, one side of which is earthed, consisting of a resistance of value R in series with a capacitance of value C in all of the combinations specified in the following table :—

C.	300	400	500	600	750	Picofarads
R.	3.6	2.8	2.2	2	1.9	ohms

4. AS TO RULE 6.—Nothing in Rule 6 of these Rules shall apply to equipment which is part of an existing installation, or to equipment, being equipment referred to in paragraph 1 or paragraph 4 of this Schedule, which had been installed before 19th November, 1954.

5. AS TO RULE 8.—Nothing in paragraph (1) of Rule 8 of these Rules shall require any parts or wiring in an existing installation to be isolated automatically from all sources of electrical energy when the means of protection referred to therein are removed.

6. AS TO RULE 6, RULE 17 AND RULE 19.—Nothing in Rule 6, Rule 17 or Rule 19 of these Rules shall apply to any auto-alarm which complies with such of the requirements of the United Kingdom Merchant Shipping (Wireless Telegraphy) Rules, 1938, as would have been applicable to it if the said Rule had not been revoked. Provided that the radiation from the auto-alarm receiver shall not exceed 0.1 microvolt per metre when measured at a distance of one mile from the auto-alarm, or when tested in the manner set forth in sub-paragraph (10) (a) of paragraph 2 of the Seventh Schedule to these Rules.

7. AS TO RULE 31.—

(a) Any existing radiotelegraph installation in a motor lifeboat, and

(b) Any radiotelegraph installation installed in a motor lifeboat before 19th November, 1954,

which complies with such of the requirements of the United Kingdom Merchant Shipping (Life Saving Appliances) Rules, 1948, as would have been applicable to it if the said Rules had not been revoked shall be treated as complying with the requirements specified in Part I of the Fifth Schedule to these Rules if it includes the equipment specified in the following subparagraphs:—

(1) A copper earth connection, connected by at least three independent bolted connections to the hull in the case of a metal lifeboat or to a bare copper earthplate of area at least six square feet fitted below the water line in the case of a wooden lifeboat.

(2) A transmitter which is:—

(a) modulated to a depth of not less than 70 per cent ;

(b) capable of:—

(i) transmitting either type A2 or type B waves on a frequency of 500 kc/s ;

(ii) transmitting type A2 waves on a frequency of 500 kc/s ;

(iii) maintaining throughout every transmission on that frequency a frequency tolerance not exceeding plus or minus 0.5 per cent ;

(iv) transmitting over a normal range of 25 miles determined in the manner prescribed by Rule 13 of these Rules ;

(v) transmitting the alarm signal and the distress signal by means of an automatic keying device ; and

(c) if installed on or after 19th November, 1953 is capable of:—

(i) transmitting type A2 waves on a frequency of 8,364 kc/s, and

(ii) maintaining throughout every transmission on that frequency a frequency tolerance not exceeding plus or minus 0.02 per cent.

8. AS TO RULE 32.—Any portable radiotelegraph equipment for lifeboats provided before 19th November, 1953, in a ship to which these Rules apply which complies with such of the requirements of the United Kingdom Merchant Shipping (Life-Saving Appliances) Rules, 1948, as would have been applicable to it if the said Rules had not been revoked shall be treated as complying with the requirements specified in Part II of the Fifth Schedule to these Rules if the transmitter forming part of such equipment complies with the requirements specified in the following sub-paragraphs.—

the transmitter shall :—

- (a) be modulated to a depth of not less than 70 per cent ;
- (b) have an input of at least 10 watts to the anode of the final stage ;
- (c) be capable of :—
  - (i) transmitting type A2 waves on a frequency of 500 kc/s ;
  - (ii) maintaining throughout every transmission a frequency tolerance not exceeding plus or minus 0.5 per cent and
  - (iii) transmitting the alarm signal and distress signal by means of an automatic keying device.

## SECOND SCHEDULE (Rule 5 (1))

### RADIOTELEGRAPH EQUIPMENT

#### PART I.—MAIN RADIOTELEGRAPH TRANSMITTER

1. GENERAL.—The main radiotelegraph transmitter (in this Part of this Schedule referred to as "the transmitter") shall be provided with any equipment which may be necessary to enable it to be operated from the supply of energy referred to in paragraph (1) of Rule 14 of these Rules, and shall be capable of being quickly connected with the main and emergency aerials referred to in Rule 12 of these Rules.

2. TYPES OF WAVES AND FREQUENCY RANGE.—The transmitter shall be capable of adjustment for the transmission of both type A1 and A2 waves as may be required in the frequency range 405 kc/s to 525 kc/s.

3. TRANSMITTING FREQUENCIES.—The transmitter shall be capable of transmitting continuously but not simultaneously, radiotelegraph signals on the frequencies of 500 kc/s, 410 kc/s and 512 kc/s and on two of the following frequencies :—

425 kc/s, 454 kc/s, 468 kc/s and 480 kc/s.

4. RANGE OF LOAD IMPEDANCE.—The transmitter shall be capable of complying with all the requirements of this Part of this Schedule when connected to an artificial load, one side of which is earthed, consisting of a resistance of value R in series with a capacitance of value C in all of the combinations specified in the following table :—

C.	300	400	500	600	750	Picofarads
R.	3.6	2.8	2.2	2	1.9	ohms

5. POWER OF TRANSMITTER.—(1) For the purposes of this paragraph the expression "the power of the transmitter" means the total power developed in the artificial load specified in paragraph 4 of this Part of this Schedule during a period when the transmitting key is depressed and does not include power dissipated in any component forming part of the transmitter.

(2) The maximum power of the transmitter shall not be less than W watts at any frequency within its range, W being determined by the formula :—

$$W = \frac{100}{1 + \frac{500}{f}}$$

where f is the frequency in kilocycles per second at which the test is made.

(3) The transmitter shall be so designed that its power can be reduced, either continuously or in steps of not more than six decibels, to a power between 2 watts and 9 watts.

(4) When adjusted to develop its maximum rated power the transmitter shall be capable of :—

(a) continuous operation for the transmission of radiotelegraph signals at any speed up to the maximum specified in paragraph 8 of this Part of this Schedule ; and

(b) operation under steady marking or spacing conditions for a period of not less than fifteen minutes.

6. DEPTH OF MODULATION.—The depth of modulation when the transmitter is transmitting type A2 waves shall be :—

(1) not less than 80 and not more than 95 per cent when the power of the transmitter is 25 watts or more.

(2) not less than 70 and not more than 95 per cent when the power of the transmitter is less than 25 watts.

7. NOTE FREQUENCY.—The note frequency of the transmitter shall not be less than 500 and not more than 1,200 c/s.

8. SPEED OF TRANSMISSION.—The transmitter shall be capable of transmitting telegraph signals at all speeds up to 30 bauds without critical relay adjustment.

9. FREQUENCY STABILITY.—The transmitter shall be capable of maintaining a frequency tolerance of plus or minus 0.1 per cent throughout every transmission without adjustment of controls, notwithstanding variations of the impedance of the aerial or any other load to which it is connected, or variations of supply voltage within plus or minus 10 per cent.

10. SPURIOUS AND HARMONIC COMPONENTS IN THE OUTPUT SIGNAL.—

(1) The radio-frequency output of the transmitter shall be entirely free from frequency components due to spurious oscillations in any part of the transmitter.

(2) The maximum power output of the transmitter at any harmonic of the radio frequency shall not exceed 20 milliwatts, whether type A1 or type A2 waves are being transmitted.

(3) When the transmitter is transmitting dots at a speed of 30 bauds, 95 per cent of the total power radiated from the transmitter shall be radiated within plus or minus 100 c/s of the steady state carrier frequency for type A2 waves.

11. OPERATING FACILITIES.—(1) The transmitter shall be so arranged that the adjustments necessary to change it from operation on any one of the frequencies required by paragraph 3 of this Part of this Schedule to operation on any other of such frequencies can be made by one operator in a period not exceeding 10 seconds.

(2) The transmitter shall be capable of being operated on full power within 60 seconds after any part of the transmitter has been first switched on.

(3) If the transmitter is so designed and constructed that it is necessary to delay the application of certain voltages for a period after it has been switched on, the delay shall be automatically provided for by a delay switch.

(4) The transmitter shall be provided with a device which, when the transmitting key is not depressed, automatically brings into operation the main radiotelegraph receiver in conjunction with which the transmitter is operated. Means shall be provided for suppressing interference with reception caused by the transmitter.

(5) The transmitter shall be capable of being used in conjunction with an automatic keying device.

12. PROTECTIVE ARRANGEMENTS.—The transmitter shall be so designed and constructed that when the transmitting key is depressed the aerial can be disconnected or the output can be short-circuted without damage being caused to any part of the transmitter. Means shall be provided for protecting the transmitter from damage caused by excessive current or voltage.

13. CRYSTAL HOLDERS.—If the transmitter is designed for use with piezo-electric crystals it shall be suitable for use with a crystal holder complying with one of the following specifications :—

(a) a holder in the form of a rectangular parallelepiped surmounted by two projecting pins, such pins being :—

(i) situated symmetrically with respect to the width and depth of the rectangular parallelepiped ;

(ii) 0.125 inches in diameter, subject to a tolerance of plus or minus 0.002 inches ;

(iii) spaced 0.75 inches apart, subject to a tolerance of plus or minus 0.005 inches.

(iv) 0.56 inches in length, subject to a tolerance of plus or minus 0.005 inches ; and

(v) rounded at the ends.

Such parallelepiped shall be :—

1.81 inches in height, subject to a tolerance of plus 0.005 inches, or minus 0.015 inches.

- 1.6 inches in width, subject to a tolerance of minus 0.01 inches, and 0.75 inches in depth, subject to a tolerance of minus 0.01 inches, or
- (b) a holder in the form of a rectangular parallelepiped surmounted by two projecting pins, such pins being :—
- (i) situated symmetrically with respect to the width and depth of the rectangular parallelepiped ;
- (ii) 0.125 inches in diameter, subject to a tolerance of plus or minus 0.002 inches.
- (iii) spaced 0.5 inches apart subject to a tolerance of plus or minus 0.002 inches.
- (iv) 0.56 inches in length, subject to a tolerance of plus or minus 0.005 inches ; and
- (v) rounded at the ends.

Such parallelepiped shall be :—

1.34 inches in height, subject to a tolerance of plus 0.005 inches, or minus 0.015 inches.

1.18 inches in width, subject to a tolerance of minus 0.1 inches.

0.455 inches in depth, subject to a tolerance of minus 0.1 inches.

14. ARTIFICIAL AERIAL.—An artificial aerial shall be provided which shall include an indicator or lamp to indicate the passage of radio-frequency currents, and shall be suitable for testing the transmitter on full power.

15. METER.—The transmitter shall be provided with an aerial ammeter.

PART II.—MAIN RADIOTELEGRAPH RECEIVER

1. GENERAL.—The main radiotelegraph receiver (in this Part of this Schedule referred to as "the receiver") may consist of a single unit or of separate units, each of which is capable of reception on one or more of sections of the frequency range specified in paragraph 2 of this Part of this Schedule, and shall be capable of being quickly connected with the main and emergency aerials referred to in Rule 12 of these Rules.

(2) Each unit of the receiver shall bear a plate stating the frequency range it is intended to cover.

(3) The receiver shall not be constructed for operation in whole or in part from energy supplied by dry batteries.

2. FREQUENCY RANGE AND TYPES OF WAVES.—The receiver shall be capable of receiving signals within the frequency ranges and of the types specified in the following table :—

Frequency range	Type of wave
15 to 20 kc/s (inclusive)	A1
100 to 160 kc/s "	A1
160 to 1,500 kc/s "	A1, A2, B
1.5 to 4 Mc/s "	A1, A2, A3
4 to 25 Mc/s .. "	A1, A2, A3

3. RECEPTION FACILITIES.—The receiver shall be capable of headphone reception throughout the frequency ranges specified in Paragraph 2 of this Part of this Schedule.

4. CONTROLS.—The receiver shall be provided with :—

- (1) separate radio-frequency and audio-frequency gain controls ;
- (2) a means for reducing the receiver gain when the transmitting key of the transmitter is depressed, so that signals may be heard without inconvenience to the operator or damage to the receiver when the transmitter is keyed at signalling speeds up to 30 words per minute ;
- (3) a switch for disconnecting the device, if any, for reducing the effect of impulsive noise signals ;
- (4) tuning controls which permit :
  - (a) rapid tuning throughout the frequency range ; and
  - (b) fine tuning by bandspread or other method, controlled by a knob of at least two inches diameter, the backlash of which shall not exceed one degree, and which shall be so geared that, after any backlash has been taken up, a rotation of one degree will not change the frequency of tune by more than the amount indicated in the following table :—

<i>Frequency range</i>	<i>Change of frequency per degree : Parts in 10<sup>4</sup></i>
15 kc/s to 1.5 Mc/s	3
1.5 Mc/s to 25 Mc/s	1

(5) accurate means of resetting tune ; if a logging scale is provided for that purpose one inch on the scale shall correspond to a frequency change of not more than one per cent ;

(6) a scale for use with the means of rapid tuning referred to in subparagraph (4) (a) of this paragraph ; the scale shall be calibrated directly in frequency unless calibration charts are provided for use therewith.

5. GENERAL METHOD OF TESTING.—The receiver shall comply with the requirements of paragraphs 6 to 17, inclusive, of this Schedule, when tested in the following manner, except where another manner of testing is specified in the said paragraphs :—

(1) An artificial aerial shall be used for the test and shall consist of a 75 ohm non-inductive resistor if the test is conducted at frequencies above 4 Mc/s, and a 10 ohm resistor in series with a capacitor having any value between 200 and 600 picofarads if the test is conducted at frequencies below 4 Mc/s.

(2) Type A2 signals used in the test shall be modulated to a depth of 30 per cent and shall have a note frequency of 400 c/s.

(3) The frequency of the interfering or unwanted signals applied shall not be restricted to the frequency range of the receiver.

(4) The standard audio-frequency output level of the receiver for headphone reception (hereafter in this Part of this Schedule referred to as "the standard output") shall be one milliwatt into a resistance substantially equal to the modulus of the impedance of the telephone receivers at 1000 c/s.

6. SELECTIVITY.—(1) Subject to the provisions of sub-paragraph (3) of this paragraph the selectivity preceding the final detector of the receiver shall be variable, either continuously or in steps and shall satisfy the following requirements throughout the frequency ranges specified :—

Bandwidth setting .. .. .	Wide	Inter- mediate	Narrow	Very narrow
Frequency range .. .. .	1.5 Mc/s to 25 Mc/s	160 kc/s to 25 Mc/s	15 kc/s to 25 Mc/s	15 kc/s to 160 kc/s
Discrimination of not more than 6 decibels to be obtained at frequencies removed from tune by .. .. .	4 kc/s	1.5 kc/s	0.5 kc/s (does not apply below 100 kc/s)	—
Discrimination of at least 30 decibels to be obtained at all frequencies removed from tune by .. .. .	12 kc/s	6 kc/s	2.5 kc/s	0.75 kc/s
Discrimination of at least 60 decibels to be obtained at all frequencies removed from tune by .. .. .	24 kc/s	12 kc/s	5 kc/s	5 kc/s
Discrimination of at least 90 decibels to be obtained at all frequencies removed from tune by .. .. .	50 kc/s	35 kc/s	25 kc/s	25 kc/s
Provided that the discrimination against an interfering signal of frequency greater than 1.5 Mc/s need not exceed 60 decibels.				

(2) If the receiver is a superheterodyne receiver :—

(a) the image response ratios thereof shall not be less than the following :

Frequency of wanted signals	Image response ratio
15 to 1,000 kc/s .. .. .	80 decibels
1 to 1.5 Mc/s .. .. .	70 decibels
1.5 to 7 Mc/s .. .. .	60 decibels
7 to 15 Mc/s .. .. .	40 decibels
above 15 Mc/s .. .. .	25 decibels

(b) the intermediate frequency response ratios thereof shall not be less than the following :—

Intermediate frequency	Intermediate frequency response ratio
Between 140 and 1,600 kc/s .. .. .	90 decibels
Outside the above limits .. .. .	60 decibels

(3) Notwithstanding the provisions of sub-paragraph (1) of this paragraph the very narrow bandwidth setting of the receiver may be provided by an audio-frequency note filter which shall have :—

(a) a midband frequency of one kilocycle per second,

(b) a discrimination of at least 20 decibels at all frequencies outside a band 700 c/s wide,

and shall be capable of being switched in or out of circuit at will.

7. SENSITIVITY.—The standard output of the receiver shall be obtained at all bandwidth settings, and with the automatic gain control both on and off, with an input not exceeding the following levels :—

<i>Frequency</i>	<i>Maximum input for type A1 waves</i>	<i>Maximum input type A2 waves</i>
15—160 kc/s .. .. .	30 decibels above one microvolt.	Does not apply.
160—1,500 kc/s. . . . .	20 decibels above one microvolt.	30 decibels above one microvolt.
1.5—10 Mc/s .. .. .	10 decibels above one microvolt.	20 decibels above one microvolt.
10—25 Mc/s .. .. .	20 decibels above one microvolt.	30 decibels above one microvolt.

8. SIGNAL/NOISE RATIO.—(1) The signal/noise ratio of the receiver shall not be less than the ratio specified in the following table, when receiving any signal being either a type A1 signal or a type A2 signal, of the maximum input specified in paragraph 7 of this Part of this Schedule when the receiver gain is adjusted to give the standard output and the note filter, if any, is switched out of circuit :—

<i>Frequency</i>	<i>Bandwidth setting</i>	<i>Signal/noise ratio</i>
15-160 kc/s .. .. .	Narrow .. .. .	10 decibels
160-1,500 kc/s .. .. .	Intermediate .. .. .	10 decibels
1.5-4 Mc/s .. .. .	Wide .. .. .	10 decibels
4-10 Mc/s .. .. .	Wide .. .. .	20 decibels
10-25 Mc/s .. .. .	Wide .. .. .	25 decibels

(2) For the purposes of this paragraph spurious whistles shall be regarded as noise.

9. AUTOMATIC GAIN CONTROL.—(1) The receiver shall be provided with an automatic gain control, capable of operating efficiently on types A1, A2 and A3 waves of all frequencies between 1,500 kc/s and 25 Mc/s, and which can be switched out of circuit.

(2) When the receiver is adjusted to give the standard output with a type A2 input signal 10 decibels above the appropriate maximum input specified in paragraph 7 of this Part of this Schedule on any frequency between 1.5 and 25 Mc/s :—

(a) an increase in input of 20 decibels shall result in an improvement in the signal/noise ratio of at least 15 decibels, and

(b) an increase in input of 60 decibels shall not increase the output by more than 10 decibels.

(3) The charge time constant of the automatic gain control system shall be between .05 and .2 seconds and the discharge time constant thereof shall be between 0.5 and 2 seconds.

10. OUTPUT LIMITING.—An increase in the input to the receiver by 60 decibels when :—

- (1) the automatic gain control is switched off, and
  - (2) the receiver is adjusted to give the standard output with a type A1 input signal 20 decibels above the appropriate maximum input specified in paragraph 7 of this Part of this Schedule,
- shall not increase the output by more than 10 decibels.

11. BLOCKING.—The change in the output of the receiver shall not exceed 3 decibels when :—

- (a)—(i) the bandwidth is set at “intermediate”,
- (ii) the automatic gain control is in operation,
- (iii) the receiver is adjusted to give the standard output with an input wanted signal of type A2 at a level of 60 decibels above one microvolt and of any frequency between 160 kc/s and 25 Mc/s, and
- (iv) a type A1 input signal at a level of 100 decibels above one microvolt and at a frequency 10 kc/s above or below the wanted frequency is then simultaneously applied ; or
- (b)—(i) the bandwidth is set at “narrow”,
- (ii) the automatic gain control is switched off,
- (iii) the receiver is adjusted to give the standard output with an input wanted signal of type A1 at a level 30 decibels above one microvolt and of any frequency between 15 and 160 kc/s, and
- (iv) a type A1 input signal of a level of 70 decibels above one microvolt and at a frequency 5 kc/s above or below that of the wanted frequency is then simultaneously applied.

12. CROSS MODULATION.—The receiver shall not produce an output of level higher than 30 decibels below the standard output when :—

- (1) the bandwidth is set at “intermediate”,
- (2) the automatic gain control is in operation,
- (3) the receiver is adjusted to give the standard output with an input wanted signal of type A2 at a level of 60 decibels above one microvolt and of any frequency between 160 kc/s and 25 Mc/s.
- (4) the modulation of the signal is switched off, and
- (5) a type A2 input signal of level 90 decibels above one microvolt and frequency 10 kc/s above or below the wanted frequency is then simultaneously applied.

13. INTERMODULATION AND HARMONIC PRODUCTION.—An output exceeding the standard output shall not be produced by the receiver when :—

- (a)—(i) the bandwidth is set at “intermediate”,
- (ii) the automatic gain control is switched off,

- (iii) the receiver is adjusted to give the standard output with an input wanted signal of type A2 at a level 30 decibels above one microvolt and at any frequency between 160 kc/s and 550 kc/s,
- (iv) the input wanted signal has been removed, and
- (v) any two interfering signals one of type A1 and the other of type A2 each of a level 110 decibels above one microvolt and of such frequency as to give no appreciable output when applied alone and of which the frequency difference or frequency sum is the same as the frequency of the wanted signal, are then simultaneously applied ; or
- (b)—(i) the bandwidth is set at "intermediate",
- (ii) the automatic gain control is switched off,
- (iii) the receiver is adjusted to give the standard output with an input wanted signal of type A2 at a level 30 decibels above one microvolt and at any frequency between 280 kc/s and 550 kc/s,
- (iv) the input wanted signal has been removed, and
- (v) a type A2 signal, the frequency of which is half that of the wanted signal and at a level 116 decibels above one microvolt is applied.

14. FIDELITY.—The maximum change in level of the output of the receiver shall be less than eight decibels while the modulation frequency of an input signal of constant level and modulation depth is varied continuously from 300 c/s to 2,500 c/s when the bandwidth is set at "wide" for the reception of type A3 waves having a frequency above 1,500 kc/s. The receiver shall comply with the foregoing requirements when the level and modulation depth of the input signal are such that the output of the receiver does not exceed the standard output.

15. NON-LINEAR DISTORTION.—With the automatic gain control switched on, the total harmonic content of the audio-frequency output of the receiver at any output not exceeding the standard output shall not exceed :—

(1) 5 per cent with an input signal of a frequency of one megacycle per second at any level between 30 decibels and 80 decibels above one microvolt and sinusoidally modulated to a depth of 30 per cent at 400 c/s.

(2) 15 per cent with such input signal modulated to a depth of 80 per cent at 400 c/s.

16. TUNING DRIFT AND STABILITY.—The tuning drift and stability of the receiver shall comply with the following requirements :—

(a) After the receiver has been switched on for 5 minutes the changes of tune frequency during any period of 5 minutes shall not exceed the value shown in the second column of the following table within the frequency ranges shown in the first column thereof :—

Frequency ranges	Maximum change (parts in $10^4$ )
15 kc/s to 1.5 Mc/s .. .. .	3
1.5 Mc/s to 25 Mc/s .. .. .	1

(b) A change of 5 per cent in any one of the supply voltages to the receiver shall not produce a maximum change of tune frequency exceeding the value shown in the second column of the following table within the frequency ranges shown in the first column thereof :—

<i>Frequency ranges</i>	<i>Maximum change (parts in 10<sup>4</sup>)</i>
15 kc/s to 1.5 Mc/s	3
1.5 Mc/s to 25 Mc/s	1

(c) A change in ambient temperature of 5°C. within the range of 0° to 50°C. applied after the receiver has been switched on for one hour shall not produce a maximum change of tune frequency exceeding the value shown in the second column of the following table within the frequency ranges shown in the first column thereof :—

<i>Frequency ranges</i>	<i>Maximum change (parts in 10<sup>4</sup>)</i>
15 kc/s to 1.5 Mc/s	10
1.5 Mc/s to 25 Mc/s ..	3

17. HETERODYNE NOTE STABILITY.—The heterodyne note stability of the receiver shall be such that :—

(1) the frequency, of a heterodyne note which is initially one kilocycle per second shall not vary by more than 100 c/s when the appropriate input level specified in sub-paragraph (2) of paragraph 10 of this Part of this Schedule is increased by not more than 60 decibels,

(2) it is possible at all input levels within the range specified in sub-paragraph (1) of this paragraph, to obtain a beat note of 200 c/s when tuning either towards or away from zero beat.

18. RADIATION.—(1) The receiver when in use shall not produce a field exceeding 0.1 microvolt per metre, when measured at a distance of one mile from the receiver.

(2) The receiver shall be deemed to comply with the requirement of sub-paragraph (1) of this paragraph if, when :—

(a) the receiver is placed centrally in a screened earthed enclosure of dimensions at least six feet cube,

(b) the earth terminal of the receiver is connected to the inside of the screen,

(c) the aerial terminal is connected through an unscreened four-turn rectangular search coil situated within the said enclosure and of dimensions one foot square and an unscreened lead to a resistive measuring instrument and mounted outside the enclosure and having its other terminal earthed, and

(d) the receiver is then energised and unscreened headphones are connected thereto, the power measured by the measuring instrument does not exceed  $4 \times 10^{-10}$  watts whatever the resistance of the measuring instrument or the adjustments of the receiver, notwithstanding that the search coil be short circuited or moved in any way, provided that it does not approach within six inches of the receiver case.

## PART III.—EMERGENCY RADIOTELEGRAPH TRANSMITTER

1. GENERAL.—The emergency radiotelegraph transmitter (in this Part of this Schedule referred to as "the transmitter"), shall be provided with all equipment necessary to enable it to operate from the emergency source of energy referred to in paragraph (2) of Rule 14 of these Rules, and shall be capable of being quickly connected with the main and emergency aerials referred to in Rule 12 of these Rules.

2. TYPES OF WAVES AND FREQUENCY RANGE.—The transmitter shall be capable of transmitting continuously type A2 waves on the frequency of 500 kc/s.

3. SOURCE OF ENERGY.—(1) The transmitter shall be capable of operation from the emergency source of energy referred to in paragraph (2) of Rule 12 of these Rules.

(2) If a vibrator power unit is employed, a standby vibrator, arranged in such manner that it may be immediately switched into circuit, shall be provided.

4. RANGE OF LOAD IMPEDANCE.—When connected to an artificial load, one side of which is earthed, consisting of a resistance of value R in series with a capacitance of value C, the transmitter shall meet the requirements of this Part of this Schedule with all the combinations of R and C specified in the following table :—

C	250	300	400	500	600	750	Picofarads
R	4	3.6	2.8	2.2	2	1.9	Ohms

5. POWER OF TRANSMITTER.—(1) For the purposes of this paragraph the power of the transmitter shall be taken to be the mean power developed in the artificial load during a period when the transmitting key is depressed, and shall not include power dissipated in any component forming part of the transmitter.

(2) The power of the transmitter shall not be less than 15 watts when the source of energy is developing 90 per cent of its rated voltage.

(3) When adjusted to develop its maximum power, the transmitter shall be capable of :—

(a) continuous operation for the transmission of telegraph signals at any speed up to the maximum specified in paragraph 8 of this Part of this Schedule ;

(b) operation under steady marking or steady spacing conditions for a period of not less than 15 minutes.

6. MODULATION.—(1) The carrier wave shall be modulated to a depth of not less than 75 per cent and not more than 100 per cent.

(2) The harmonic content of the modulating envelope shall not exceed 30 per cent.

7. NOTE FREQUENCY.—The note frequency of the transmitter shall not be less than 500 c/s or more than 1,200 c/s.

8. SPEED OF TRANSMISSION.—The transmitter shall be capable of transmitting telegraph signals at all speeds up to 25 bauds without critical adjustment of relays.

9. FREQUENCY STABILITY.—The transmitter shall be capable of maintaining a frequency tolerance of plus or minus 0.5 per cent throughout every transmission without adjustment of controls notwithstanding variations of the impedance of the aerial or of any other load to which it is connected, or variation of supply voltage within plus or minus 10 per cent.

10. OPERATING FACILITIES.—(1) The transmitter shall be capable of being operated on full power within six seconds after it has been switched on.

(2) The transmitter shall be capable of being used in conjunction with the automatic keying device specified in Part V of this Schedule.

11. PROTECTIVE ARRANGEMENTS.—The transmitter shall be so designed and constructed that when the transmitter is adjusted to develop its maximum power and when the transmitting key is depressed the aerial can be disconnected or the output can be short-circuited without damage being caused to any part of the transmitter.

12. CRYSTAL HOLDERS.—If the transmitter is designed for use with piezo-electric crystals it shall be suitable for use with a crystal holder specified in paragraph 13 of Part 1 of this Schedule.

13. ARTIFICIAL AERIAL.—An artificial aerial shall be provided which shall include an indicator or lamp to indicate the passage of radio-frequency currents and shall be suitable for testing the transmitter on full power.

14. METER.—The transmitter shall be provided with an aerial ammeter.

15. USE FOR NORMAL COMMUNICATIONS.—If the transmitter is used otherwise than in an emergency or for the test required by paragraph (4) (b) of Rule 20, paragraphs 3, 6, 8, 9, 10 and 11 of Part 1 of this Schedule shall apply in relation to it as they apply in relation to the main transmitter.

#### PART IV.—EMERGENCY RADIOTELEGRAPH RECEIVER

1. GENERAL.—The emergency radiotelegraph receiver (in this Part of this Schedule referred to as "the receiver"), unless it is a receiver forming part of an auto-alarm which complies with paragraph 7 of the Seventh Schedule to these Rules, shall be capable of being rapidly connected to the emergency aerial referred to in Rule 12 of these Rules.

2. FREQUENCY RANGE AND TYPES OF WAVES.—Subject to the provisions of paragraph 3 of this Part of this Schedule, the receiver shall be capable of receiving type A2 waves and type B waves in each case throughout the frequency range 488 kc/s to 513 kc/s, and for that purpose a wide band-pass shall be provided.

3. RECEPTION FACILITIES.—The receiver shall be capable of headphone reception and loud-speaker reception throughout the frequency range specified in paragraph 2 of this Part of this Schedule, unless two emergency receivers are provided, one of which is capable of headphone reception, with or without tuning, throughout the said range and the other of which is capable of loud-speaker reception throughout the said range without tuning.

4. SOURCE OF ENERGY.—(1) The receiver shall be capable of operation both from the main source of electrical energy required by paragraph (1) of Rule 14 of these Rules and the emergency source of electrical energy required by paragraph (2) of that Rule. Provided that if the ship is equipped with two emergency receivers as aforesaid, the receiver capable of loud-speaker reception shall be required to be capable of operation only from the said main source of electrical energy.

(2) The receiver shall comply with the requirements of paragraphs 7 to 15 inclusive of this Part of this Schedule notwithstanding variations in the supply voltage within the range :—

(i) plus 5 per cent and minus 10 per cent of the nominal voltage when operated from the emergency source of electrical energy required by paragraph (2) of Rule 14 of these Rules and

(ii) plus and minus 10 per cent of the nominal voltage when operated from the main source of electrical energy required by paragraph (1) of Rule 14 of these Rules.

5. CONTROLS.—The receiver shall be provided with :—

(1) a manual gain control ;

(2) if only a single emergency receiver is provided, a switch for changing the receiver from operation from the main source of electrical energy referred to in paragraph (i) of Rule 14 of these Rules to the emergency source of electrical energy referred to in paragraph (2) of that Rule ; and

(3) if the receiver is designed to tune to frequencies additional to the frequency range specified in paragraph 2 of this Part of this Schedule, a switch for changing reception to the frequency range referred to in that paragraph.

6. METHOD OF TESTING.—The receiver shall comply with paragraphs 7 to 15 inclusive of this Part of this Schedule when tested in the following manner except where another manner of testing is specified in the said paragraphs :—

(1) An artificial aerial shall be used for the test and shall consist of a 10 ohm resistor in series with a capacitor having any value between 200 and 600 picofarads.

(2) Type A2 signals used in the test shall be modulated to a depth of 30 per cent and shall have a note frequency of 400 c/s.

(3) The standard audio-frequency output level (hereafter in this Part of this Schedule referred to as "the standard output") of the receiver shall be :—

(a) for headphone reception 10 decibels below one milliwatt into a resistance substantially equal to the modulus of the impedance of the telephone receivers at 1,000 c/s, and

(b) for loud-speaker reception 17 decibels above one milliwatt into a resistance that loads the output valve with the load appropriate to the valve.

7. SELECTIVITY—(1) Subject to the provisions of sub-paragraph (2) of this paragraph, the selectivity preceding the final detector of the receiver shall, if it is provided with a wide band-pass, satisfy the following requirements at the relative frequencies specified :—

(a) not more than 4 decibels discrimination relative to the maximum response at frequencies between 488 and 513 kc/s inclusive ;

- (b) at least 30 decibels discrimination relative to the maximum response at frequencies below 475 kc/s and above 525 kc/s ;
- (c) at least 60 decibels discrimination relative to the maximum response at frequencies below 450 kc/s and above 550 kc/s and
- (d) at least 90 decibels discrimination relative to the maximum response at frequencies below 400 kc/s and above 600 kc/s.
- (2) If the receiver is a superheterodyne receiver the intermediate frequency response ratio shall not be less than 60 decibels provided that the intermediate frequency is outside the limits 140 kc/s and above 1,600 kc/s.
- (3) If any emergency receiver, being a receiver capable of headphone reception is tunable over the frequency range specified in paragraph 2 of this Part of this Schedule, the selectivity preceding the final detector at all frequencies within the said range shall satisfy the requirements set forth in the following table :—

Discrimination	Corresponding Bandwidth
10 decibels	Not less than 4 kc/s
30 decibels	No greater than 50 kc/s
60 decibels	No greater than 100 kc/s
Greater than 60 decibels	Greater than 100 kc/s

8. SENSITIVITY.—The standard output shall be obtained with an input signal of type A2 not exceeding 40 decibels above one microvolt.

9. Signal/Noise Ratio.—The signal/noise ratio, with an input signal of type A2 of 40 decibels above one microvolt and when the manual gain control is adjusted to give the standard output, shall not be less than 20 decibels.

10. BLOCKING.—If the receiver is intended for loudspeaker reception the change in the output of the receiver shall not exceed 3 decibels when :—

- (1) the receiver is adjusted to give the standard output with an input wanted signal of type A2 at a level of 60 decibels above one microvolt and of a frequency of 500 kc/s and
- (2) a type A1 input signal at a level of 100 decibels above one microvolt and of a frequency of 440 kc/s or 560 kc/s is then simultaneously applied.

11. CROSS MODULATION.—If the receiver is intended for loudspeaker reception, the receiver shall not produce an output of level higher than 30 decibels below the standard output when :—

- (1) the receiver is adjusted to give the standard output with an input wanted signal of type A2 at a level of 60 decibels above one microvolt and of a frequency of 500 kc/s.
- (2) the modulation of the signal is switched off, and
- (3) a type A2 at a level of 90 decibels above one microvolt and of a frequency of 425 kc/s or 575 kc/s is then simultaneously applied.

12. INTERMODULATION AND HARMONIC PRODUCTION.—If the receiver is intended for loudspeaker reception an output exceeding the standard output shall not be produced by the receiver when :—

- (1) the receiver is adjusted to give the standard output with an input wanted signal of type A2 at a level of 40 decibels above one microvolt and of a frequency of 500 kc/s.

(2) the input wanted signal has been removed, and

(3) (a) any two interfering signals, one of type A1 and the other of type A2, each at a level of 110 decibels above one microvolt and of such frequency as to give no appreciable output when applied alone, and of which the frequency sum or difference is 500 kc/s, are then simultaneously applied or

(b) a signal of type A2 at a level of 116 decibels above one microvolt and of a frequency of 250 kc/s is applied.

13. **OUTPUT LIMITING.**—If the receiver is intended for loudspeaker reception the receiver shall be provided with an efficient and automatic means of reducing the gain during the reception of strong signals.

14. **TUNING DRIFT AND STABILITY.**—The tuning drift and the stability of the receiver shall be such that within five minutes of the receiver being switched on the requirements of paragraph 7 of this Part of this Schedule shall be met.

15. **FIDELITY.**—The fidelity of the receiver shall be such that a change in the audio-frequency output shall be less than 8 decibels when the modulation frequency of the input signal is varied continuously from 400 c/s to 1,400 c/s for the level and modulation depth of the input signal being kept constant. For the purposes of this paragraph the input signal may have any level and depth of modulation provided the output of the receiver does not exceed the standard output.

16. **RADIATION.**—(1) The receiver when in use shall not produce a field exceeding 0.1 microvolt per metre when measured at a distance of one mile from the receiver.

(2) The receiver shall be deemed to comply with the requirement of sub-paragraph (1) of this paragraph if, when :—

(a) the receiver is placed centrally in a screened earthed enclosure of dimensions at least six feet cube,

(b) the earth terminal of the receiver is connected to the inside of the screen,

(c) the aerial terminal is connected through an unscreened four-turn rectangular search coil situated within the said enclosure and of dimensions one foot square and an unscreened lead to a resistive measuring instrument mounted outside the enclosure and having its other terminal earthed, and

(d) the receiver is then energised and unscreened headphones are connected thereto, the power measured by the measuring instrument does not exceed  $4 \times 10^{-10}$  watts whatever the resistance of the measuring instrument or the adjustment of the receiver, and notwithstanding that the search coil is short-circuited or moved in any way, without approaching within six inches of the receiver case.

#### PART V AUTOMATIC KEYING DEVICE

1. The automatic keying device (in this Part of this Schedule referred to as "the device") shall be capable of :—

(1) being connected in place of the manual transmitting key by a jack or other efficient means, to

(a) the main radiotelegraph transmitter,

(b) the emergency radiotelegraph transmitter, and  
 (c) the auto-alarm test signal generator referred to in paragraph 1 of the Seventh Schedule to these Rules ;

(2) when connected to any of the aforesaid equipment,

(a) keying automatically the alarm signal specified in paragraph 3 of this Part of this Schedule and immediately thereafter stopping and opening the keying circuit unless re-set or re-wound ; and

(b) keying automatically the distress call specified in paragraph 4 of this Part of this Schedule in such manner that if the device is used without attention the automatic keying of the distress call will be repeated once every twelve minutes.

The device shall not be capable of keying any signals other than those specified in paragraphs 3 and 4 of this Part of this Schedule.

2. When switched out of circuit after transmission of the distress call, the device shall be capable of being re-set by automatic or manual means so that after the device has again been switched into circuit keying shall commence within ten seconds at the beginning of the distress call.

If the re-setting is by manual means the device shall include a means for indicating when re-setting is necessary.

3. The alarm signal referred to in sub-paragraph (2) of paragraph 1 of this Part of this Schedule shall consist of twelve four second dashes separated by one second spaces, the length of the dashes and spaces being maintained within a tolerance of plus or minus 0.2 second.

4.—(1) The distress call referred to in the said sub-paragraph shall consist of the following signals in the following order :—

(a) the distress signal . . . - - - . . . , repeated three times ;

(b) the morse characters for the word DE ; and

(c) a long dash.

Provided that the morse characters for the word DE may be omitted.

The characters of the distress signal shall be keyed at a speed of not more than 16 words per minute and the duration of the long dash shall not be less than 20 seconds.

The total length of the distress call shall not exceed 90 seconds.

(2) The mechanism for keying the distress call specified in sub-paragraph (1) of this paragraph shall be such that it can be readily adapted so as to enable the device to key, within a period of 90 seconds, a distress call consisting of the following signals in the following order :—

(a) the distress signal . . . - - - . . . , repeated three times ;

(b) the morse characters for the word DE ;

(c) the morse characters for the ship's call sign three times ; and

(d) a long dash having a duration of at least 20 seconds.

5. If the device is electrically operated, the source of electrical energy by which it is operated shall be the emergency source of electrical energy referred to in paragraph (2) of Rule 14 of these Rules.

## THIRD SCHEDULE

## RADIOTELEPHONE INSTALLATION

(Rule 5 (2))

1. DEFINITION.—In this Schedule the expression "the equipment" includes a radiotelephone transmitter and receiver, and all other equipment necessary for the operation of the installation, but does not include an aerial.

2. TYPES OF WAVE AND FREQUENCY RANGE.—(1) The equipment shall be capable of adjustment for the transmission and reception of both type A2 and type A3 waves on any frequency within the frequency range 1,600 kc/s to 3,800 kc/s.

(2) The facilities for the transmission of type A2 waves shall be so designed that they can be rendered incapable of operation by internal disconnection.

3. OPERATING FREQUENCIES.—The equipment shall be capable of transmitting and receiving type A2 and type A3 waves, and shall be capable of being set for both transmission and reception on the radiotelephone distress frequency and on at least the number of spot frequencies specified in the following table, and selected at any points within the relative frequency limits therein specified. The transmitter shall not be capable of being operated otherwise than on spot frequencies.

Number of spot frequencies		Frequency Limits
Transmitting	Receiving	
4 and 2 and 1	4 and 2 and 1	1,600 to 2,850 kc/s 3,500 to 3,800 kc/s 1,600 to 3,800 kc/s

4. POWER SUPPLY.—The equipment shall be capable of being operated from the supply of electrical energy required by Rule 25 of these Rules.

5. TRANSMITTER.—(1) Selection of any of the transmitter frequencies referred to in paragraph 3 of this Schedule shall be by a single switch or push button.

(2) The transmitter shall comply with the requirements specified in this Schedule when connected to each of the artificial aerials specified in the following table :—

Frequency range	Artificial aerials (all elements in series)		
	Resistance Ohms	Capacitance Picofarads	Inductance Microhenrys
Below 3 Mc/s .. ..	6	250	—
Above 3 Mc/s .. ..	10	250	—
	40	250	8

(3) The total carrier power delivered by the transmitter to the aforesaid artificial load (not including power dissipated in an aerial tuning inductor or any other component forming part of the transmitter) shall on any frequency between 1,600 kc/s and 3,800 kc/s be not less than 15 watts and not more than 100 watts and means shall be provided for reducing such power to a power between 5 watts and 10 watts.

(4) A peak limiter shall be provided to prevent over-modulation of the transmitter.

(5) The speech modulation of the transmitter shall be such that :—

(a) the frequency response of the microphone and transmitter together shall not vary by more than 7.5 decibels from a value which rises at the rate of 6 decibels per octave from 250 c/s to 2,500 c/s.

(b) the response relative to the peak response shall not be higher than :—

(i) minus 20 decibels at all frequencies above 5,000 c/s,  
5,000 c/s and.

(ii) minus 40 decibels at all frequencies above 5,000 c/s.

(6) The modulating system shall be such that the peak modulation of the transmitter lies between 80 and 95 per cent for any sound pressure the root mean square value of which, measured in the plane of the microphone mouthpiece with a pure wave of 1,000 c/s., lies between 25 dynes and 100 dynes per square centimetre.

(7) With the transmitter operating at its rated power or below and modulated to a depth of 90 per cent by a sinusoidal wave of frequency 400 c/s applied to the microphone terminals, and with the peak limiter rendered inoperative, the harmonic contents of the modulated output voltage shall not exceed 10 per cent.

(8) The transmitter shall be capable of maintaining a frequency tolerance of plus or minus 0.02 per cent throughout every transmission without adjustment of any control and notwithstanding variations of the impedance of the aerial or other load to which it is connected, or variations of supply voltage within plus or minus 10 per cent.

(9)—(a) The radio-frequency output of the transmitter shall be free from frequency components due to spurious oscillations in any part of the equipment.

(b) The output power at any harmonic of the radio-frequency shall not exceed 0.1 watt.

(c) With the microphone open or short-circuited :—

(i) the total noise and hum power in the output wave shall be at least 20 decibels below the carrier power ;

(ii) the total noise and hum power contained in the sidebands corresponding to audio-frequencies between the limits of 250 c/s and 3,000 c/s shall be at least 40 decibels below the carrier power.

(10) The transmitter shall be such that :—

(a) in not more than 10 seconds one operator can carry out all such adjustments as are necessary to change the transmitter from operation on any one of the frequencies referred to in paragraph 3 of this Schedule to operation on any other of such frequencies ;

(b) if the transmitter is so designed and constructed that it is necessary to delay the application of certain voltages for a period after it has been switched on, the delay shall be automatically provided by a delay switch ;

(c) an indicator shall show when the transmitter is ready for operation ;  
and

(d) a skilled person can make alterations in the spot frequencies within the limits specified in paragraph 3 of this Schedule without removing the installation from the ship.

(11) If the transmitter is adjusted for the transmission of type A2 waves :—

(a) the depth of modulation shall not be less than 70 per cent and not more than 100 per cent ;

(b) the note frequency shall not be less than 500 c/s and not more than 1,200 c/s ; and

(c) the transmitter shall be capable of transmitting telegraph signals at all speeds up to 30 bauds.

(12) The transmitter shall be so designed and constructed that when it is adjusted for maximum power the aerial may be disconnected or the output short-circuited without damage being caused to any part of the installation. Means shall be provided for protecting the transmitter from damage caused by excessive current or voltage.

6. RECEIVER.—(1) Means shall be provided to enable each of the receiver spot frequencies referred to in paragraph 3 of this Schedule to be selected by a single operation.

(2) The receiver shall be capable of both telephone and loudspeaker reception.

(3) The receiver shall be provided with :—

(a) a manual audio-frequency gain control ; and

(b) an automatic gain control capable of efficient operation on type A2 and type A3 waves.

(4) Any peak limiter or other device included in the detector or output circuits of the receiver for the purpose of reducing the effect of impulsive noise signals shall be capable of being disconnected by means of a switch.

(5) The receiver shall comply with the requirements of sub-paragraphs (6) to (14) inclusive, of this paragraph when tested in the following manner, except where another manner of testing is specified in the said sub-paragraphs :—

(a) artificial aerials with the characteristics specified in the table set forth in sub-paragraph (2) of paragraph 5 of this Schedule shall be used for the test ;

(b) type A2 signals used for the test shall be modulated to a depth of 30 per cent with a note frequency of 400 c/s ;

(c) the standard audio-frequency output of the receiver (in this paragraph referred to as the "standard output") shall be :—

(i) for telephone receiver reception, one milliwatt into a resistance which is substantially equal to the modulus of the impedance of the telephone at 1,000 c/s ;

(ii) for loud-speaker reception, 50 milliwatts into a resistance which loads the output valve with the load appropriate to the valve.

(6)—(a) The selectivity of the receiver measured at a point immediately preceding the final detector shall satisfy the following requirements at the relative frequencies specified :—

Discrimination of not more than 6 decibels to be obtained at frequencies removed from tune by .. .. .	3 kc/s
Discrimination of at least 30 decibels to be obtained at frequencies removed from tune by .. .. .	7.5 kc/s
Discrimination of at least 60 decibels to be obtained at frequencies removed from tune by .. .. .	15 kc/s
Discrimination of at least 80 decibels to be obtained at frequencies removed from tune by .. .. .	30 kc/s

(b) If the receiver is a superheterodyne receiver :—

(i) the image discrimination shall not be less than 35 decibels at frequencies above 3 Mc/s and not be less than 40 decibels at frequencies below 3 Mc/s and

(ii) the intermediate frequency response ratios shall not be less than the following :—

<i>Intermediate frequency</i>	<i>Intermediate frequency response ratio</i>
Between 140 and 1,600 kc/s .. .. .	80 decibels
Outside the above limits .. .. .	60 decibels

(7) The signals/noise ratio of the output of the receiver shall be at least 20 decibels when the receiver is adjusted to give the standard output with an input signal of type A2 a level of 30 decibels above one microvolt.

(8) The automatic gain control shall be such that when the receiver is adjusted to give the standard output with an input signal of type A2 at a level of 30 decibels above one microvolt :—

(a) an increase in input of 20 decibels will result in an improvement in the signal/noise ratio of at least 15 decibels ; and

(b) an increase in input of 50 decibels will not increase the output by more than 10 decibels.

(9) The change in output of the receiver shall not exceed 3 decibels when the receiver is adjusted to give the standard output with an input wanted signal of type A2 at a level of 60 decibels above one microvolt and a type A1 input signal is simultaneously applied at a level of 100 decibels above one microvolt and at a frequency of 20 kc/s above or below the wanted frequency.

(10) An output of level higher than 30 decibels below the standard output shall not be produced when the receiver is adjusted to give the standard output with an input wanted signal of type A2 at a level of 60 decibels above one microvolt the modulation of the signal generator has been switched off, and a type A2 input signal is simultaneously applied at a level 90 decibels above one microvolt and at a frequency of 20 kc/s above or below the wanted frequency.

(11) An output exceeding the standard output shall not be produced when the receiver is adjusted to give the standard output with an input signal of type A2 at a level of 30 decibels above one microvolt, the wanted

signal has been removed, and two interfering signals are simultaneously applied, one of type A1 and one of type A2, each of level 100 decibels above one microvolt, of which the frequency sum or difference is the same as the frequency of the wanted signal, but neither of which will give an appreciable output when modulated and applied alone.

(12) The maximum change in level of the audio-frequency output shall be less than 8 decibels when the modulation frequency of the input signal is varied continuously from 250 c/s to 3,000 c/s, the input signal remaining constant in level and depth of modulation. When the modulation frequency is increased above 3,000 c/s the output shall fall rapidly. The input signal may have any level and depth of modulation provided the output of the receiver does not exceed the standard output.

(13) The total harmonic content of the audio-frequency output voltage of the receiver at any output not exceeding the standard output shall not exceed :—

(a) 5 per cent with an input signal at any level between 40 and 80 decibels above one microvolt and sinusoidally modulated to a depth of 30 per cent, at 400 c/s,

(b) 15 per cent with an input signal as prescribed in (a) but modulated to a depth of 80 per cent at 400 c/s.

(14) Each frequency of tune referred to in paragraph 3 of this Schedule shall be maintained within one kilocycle per second of its nominal value notwithstanding variation in the supply voltage of plus or minus 10 per cent and notwithstanding ambient temperature changes from minus 10°C to plus 40°C.

(15)—(a) The receiver shall not in normal service produce a field exceeding 0.1 microvolt per metre when measured at a distance of one mile from the receiver.

(b) The receiver shall be deemed to comply with the requirement of sub-paragraph (a) of this paragraph if, when :—

(i) the receiver is placed centrally in a screened earthed enclosure of dimensions at least six feet cube,

(ii) the earth terminal of the receiver is connected to the inside of the screen,

(iii) the aerial terminal is connected through an unscreened four-turn rectangular search coil situated within the said enclosure and of dimensions one foot square and an unscreened lead to a resistive measuring instrument mounted outside the enclosure and having its other terminal earthed, and

(iv) the receiver is then energised and unscreened headphones are connected thereto, the power measured by the measuring instrument does not exceed  $4 \times 10^{-10}$  watts whatever the resistance of the measuring instrument or the adjustment of the receiver, and notwithstanding that the search coil is short-circuited or moved in any way without approaching within six inches of the receiver case.

7. FACILITIES FOR TWO-WAY COMMUNICATION.—(1) The equipment shall be capable of changing instantaneously from transmitting to receiver and vice versa by means of a pressel or other single switch, aerial change-over relays, and such other devices as are necessary for that purpose. If, in addition, a voice-operated device is provided for that purpose the operating lag shall not exceed 10 milli-seconds, and the release lag shall not be less than 150 milli-seconds and not more than 200 milli-seconds.

(2) Means shall be provided for protecting the receiver from damage when the equipment is transmitting.

(3) Means shall be provided to assure automatically that at all times when the microphone is in use the loud-speaker is disconnected.

8. SIZE OF CONTROLS.—All controls on the receiver shall be of such size as to permit normal adjustments being performed by a person wearing thick gloves.

9. CRYSTAL HOLDERS.—If the installation is designed for use with piezo-electric crystals, it shall be suitable for use with a crystal holder specified in paragraph 13 of Part I of the Second Schedule to these Rules.

(Rules 4, 36)

**FOURTH SCHEDULE**  
**CLIMATIC AND DURABILITY TESTS**

1. In this Schedule :—

(1) references to Class B equipment shall be construed as references to equipment appropriated for use only below deck or in a deckhouse or other similar compartment ; and

(2) references to Class X equipment shall be construed as references to equipment appropriated for use or storage in the open or in an open boat.

2.—(1) Class B equipment shall be subjected to the tests named opposite the letter B in the table given in sub-paragraph (4) of this paragraph, and Class X equipment shall be subjected to the tests named opposite the letter X in that table.

(2) All such tests shall be conducted in the order in which they appear in the aforesaid table.

(3) At any time when the equipment is required by the provisions of paragraph 3 of this Schedule to be kept working for the purposes of such tests, power shall be supplied thereto at the voltage at which such equipment is designed to be operated.

**TABLE**

(4) Nature of Test	Classes of equipment to which the test shall be applied
(1) Vibration test .. .. .	B and X
(2) Bump test .. .. .	B and X
(3) Dry heat test .. .. .	B and X
(4) Damp heat test .. .. .	B and X
(5) Low temperature test .. .. .	B and X
(6) Rain Test .. .. .	X
(7) Immersion test .. .. .	X
(8) Corrosion test—salt water .. .. .	B and X
(9) Corrosion test—acid fumes (if a battery is included in the equipment) .. .. .	B and X
(10) Mould growth test .. .. .	X

3. The tests referred to in paragraph 2 of this Schedule shall be conducted respectively as follows :—

(1) **VIBRATION TEST.**—The equipment, complete with its chassis covers and shock absorbers (if any) shall, in its normal operating position, be clamped to a vibration table. The table shall be vibrated at all frequencies between 0 and  $12\frac{1}{2}$  cycles per second at an amplitude of plus or minus 0.16 cm. during which period the equipment shall be kept working continuously. The table shall be so vibrated for three periods each of which shall be of eight minutes duration. Throughout each such period the direction of the vibrations shall be perpendicular to the direction of the vibrations during the other two periods.

(2) **BUMP TEST.**—The equipment shall be subject to not less than 500 bumps at a constant rate of between one and four bumps per second with a free drop of at least 2.5 cm.

(3) **DRY HEAT TEST :—**

(a) Class B equipment shall be placed in a chamber which is maintained for a period of two hours at a constant temperature of 55°C within a tolerance of plus or minus 1°C, during which period the equipment shall be kept working continuously.

(b) Class X equipment shall be placed in a chamber which is maintained for a period of ten hours at a constant temperature of 70°C within a tolerance of plus or minus 1°C, during which period the equipment shall not be worked or tested. The said chamber shall then be cooled to a constant temperature of 55°C within a tolerance of plus or minus 1°C and the equipment shall be kept working continuously at that temperature for a period of two hours.

(4) **DAMP HEAT TEST.**—The equipment shall be prepared for the damp heat test in the following manner :—

(a) The equipment shall be placed in a chamber which within a period not exceeding two hours shall be heated from room temperature to 40°C and shall be brought to a relative humidity of not less than 95 per cent.

(b) The chamber shall be kept at a temperature of 40°C within a tolerance of plus or minus 1°C for a period of 12 hours, and at a relative humidity of not less than 95 per cent.

(c) At the beginning of the last 60 minutes of such period, all accessible surfaces and components shall be wiped dry and any fans or drying lamps provided in the equipment shall be switched on. After the fans or drying lamps have been in operation for 30 minutes and while the temperature of the chamber is still 40°C, subject to the aforesaid tolerance, the equipment shall be tested.

After the equipment has been tested the temperature of the chamber shall, in preparation for the low temperature test, be allowed to fall below 25°C the equipment remaining in the chamber.

(5) **LOW TEMPERATURE TEST.**—(a) Class B equipment shall be exposed to a temperature of minus 15°C at normal atmospheric pressure for a period of not less than twelve hours.

(b) Class X equipment shall be exposed to a temperature of minus 25°C at normal atmospheric pressure for a period of not less than twelve hours.

(6) RAIN TEST.—The equipment shall be placed in a chamber fitted with eight shower heads, the discharge end of which shall consist of a flat, non-rustable metal plate, 0.16 cm. thick, having thirty-six holes each of 0.1 cm. diameter evenly spaced in concentric circles in the following manner:—

- 16 holes on the periphery of circles of 5.1 cm. diameter.
- 8 holes on the periphery of a circle of 3.8 cm. diameter.
- 8 holes on the periphery of a circle of 2.5 cm. diameter.
- 4 holes on the periphery of a circle of 1.3 cm. diameter.

The said shower heads shall be arranged at a distance of not less than 50 cm. and not more than 80 cm. from the equipment in such a manner that spray from four of such shower heads is directed downwards at an angle of 45° at each of the four uppermost corners of the equipment, and the spray from the other four shower heads is directed horizontally at the centre of each area of the four sides of the equipment. Fresh water at room temperature and at a static pressure of not less than 15 or more than 25 pounds per square inch shall be sprayed on to the equipment from the aforesaid shower heads for a period of one hour with equipment in the position in which it is normally operated. Throughout the test the equipment shall be rotated at between 12 and 20 revolutions per minute about a vertical axis passing through the centre of the equipment.

(7) IMMERSION TEST.—The equipment in the condition in which it will normally be kept on board ship shall be immersed in water the surface of which is at least 10 cm. above the highest point of the equipment, and shall remain for a period of one hour. Upon its removal from the water the equipment shall be drained of water.

(8) CORROSION TEST (SALT WATER).—The equipment shall be placed in a chamber fitted with apparatus capable of spraying in the form of a fine mist either natural sea water or tap water containing the following salts in solution:—

Sodium Chloride	..	..	..	..	..	2.7 per cent
Magnesium Chloride	..	..	..	..	..	0.6 per cent
Calcium Chloride	..	..	..	..	..	0.1 per cent
Potassium Chloride	..	..	..	..	..	0.07 per cent

The quantity of each salt shall be subject to a tolerance of plus or minus 10 per cent.

Such spraying apparatus shall be such that the products of corrosion cannot mix with the sea water or solution contained in the spray reservoir. The equipment shall be sprayed simultaneously on all its external surfaces with the sea water or solution for a period of one hour and shall be kept working continuously for the last thirty minutes thereof. The equipment shall immediately thereafter be stored for a period of seven days at a temperature of 40°C within a tolerance of plus or minus 1°C at a relative humidity of not less than 60 per cent, and not more than 80 per cent. The equipment shall be sprayed and stored as aforesaid on four separate occasions.

(9) CORROSION TEST (ACID FUMES).—Any battery included in the equipment shall be fully charged and shall then be fitted into the equipment. If the arrangements are such that the battery can be charged without being removed from the equipment, the battery shall continue to be charged at the maximum rate appropriate to it for a period of twenty-four hours. The

equipment shall immediately thereafter be stored for a period of four weeks at a temperature of 40°C within a tolerance of plus or minus 1°C at a relative humidity of not less than 60 per cent and not more than 80 per cent.

(10) MOULD GROWTH TEST.—The equipment shall be inoculated by spraying with an aqueous suspension of mould spores containing all the cultures named in column A or all the cultures named in column B of the following table :—

<i>A</i>	<i>B</i>
Aspergillus niger ;	Aspergillus niger ;
Aspergillus amstelodami ;	Aspergillus amstelodami ;
Paecilomyces varioti ;	Aspergillus versicolor ;
Stachybotrys atra ;	Stachybotrys atra ;
Penicillium brevi-compactum ;	Penicillium brevi-compactum ;
Pencillium cyclopium ;	Cladosporum herbasum.
Chaetomium globosum.	

Immediately after it has been so sprayed the equipment shall be placed in a chamber, the temperature of which shall be maintained at any fixed value within the range 31°C to 33°C inclusive and controlled to within a tolerance of plus or minus 1°C at a relative humidity of not less than 95 per cent. The equipment shall remain in the said chamber for a period of twenty-eight days.

#### FIFTH SCHEDULE

(Rules 31 and 32)

### RADIOTELEGRAPH EQUIPMENT FOR LIFEBOATS

#### PART I

#### FIXED EQUIPMENT

1. GENERAL.—(1) The radiotelegraph equipment for lifeboats (in this Part of this Schedule referred to as "the equipment") shall include a radiotelegraph transmitter and receiver, an aerial and earth system, a source of energy and all other equipment necessary for the operation of the installation.

(2) The equipment shall be so designed that an unskilled person can readily cause it to transmit the signals referred to in paragraph 5 of this Part of this Schedule.

(3) The purpose of all controls not required for transmitting the said signals shall be clearly and permanently indicated.

(4) Simple instructions for the operation of the equipment on the frequencies specified in sub-paragraph (1) of paragraph 4 and sub-paragraph (1) of paragraph 6 of this Part of this Schedule shall be affixed in clear and permanent form to or near the equipment.

(5) All controls shall be of such size as will permit normal adjustments to be made by a person wearing thick gloves, and in particular all tuning knobs shall not be less than 2 inches in diameter.

(6) The change-over from transmitting to receiving and vice versa, including automatic change of aerial connections, shall be made by means of one switch.

(7) The equipment shall be readily removable from the lifeboat.

(8) An electric lamp of power between 3 watts and 15 watts, with a water-proof casing, shall be provided to illuminate the control panels and the aforesaid instructions.

(9) An electrical heater, connected to the ship's mains shall be provided and shall be capable of maintaining the interior of the case in which the equipment is installed at a temperature at least  $10^{\circ}\text{C}$  above the ambient temperature. The heater shall be so mounted that it will reduce the risk of the controls or cover of the equipment becoming frozen into position but will not cause any part of the installation to become overheated.

(10) All parts other than the aerial and its terminal which are not at earth potential shall be enclosed. The aerial terminal shall be guarded against accidental contact.

(11) The equipment shall be capable of complying with the performance requirements specified in this Part of this Schedule while the lifeboat engine is running, and whether or not the battery is being charged.

2. AERIAL AND EARTH SYSTEM.—(1) The equipment shall include :—  
 (a) a single-wire aerial of high conductivity stranded or braided wire capable of being supported by the lifeboat mast without the use of top-masts at a maximum height of not less than 22 feet above the waterline; and

(b) an earth system which shall be of the same material throughout and shall consist of at least three independent bolted connections :—

- (i) to the hull in the case of a metal lifeboat, or
- (ii) to a bare copper plate of area at least six square feet fixed to the hull below the waterline in the case of a wooden lifeboat.

(2) The aerial system shall be mechanically robust.

(3) All practicable steps shall be taken to reduce aerial losses to a minimum.

(4) All parts of the aerial which may come in contact with the occupants of the lifeboat when the equipment is in use shall be insulated.

3. SOURCE OF ENERGY.—(1) The equipment shall include one 24 volt battery composed of secondary cells and of a capacity sufficient to operate the receiver for four hours and immediately thereafter to run the transmitter under full-power marking conditions for two hours.

(2) If it is intended to operate a searchlight from the battery, the capacity thereof shall be at least 30 ampere hours in excess of that referred to in subparagraph (1) of this paragraph.

(3) The battery shall be capable of being completely recharged :—

(a) in not more than 20 hours from a dynamo working in conjunction with and throughout the normal range of speeds of the lifeboat engine if the battery is not in use at the same time; and

(b) from the ship's main source of electrical energy without being removed from the lifeboat.

(4) The battery shall not spill when tilted to an angle of  $60^{\circ}$  from its normal position in any direction.

(5) The battery shall be electrically isolated from the rest of the equipment when the transmitter and receiver are switched off.

(6) If a vibrator power unit is employed, a reserve vibrator shall be provided and so controlled by a change-over switch that it can be put into circuit immediately.

4. TRANSMITTER.—(1) The equipment shall include a transmitter capable of :

(a) sending continuously but not simultaneously radiotelegraph signals of type A2 waves on the frequencies of 500 kc/s and 8,364 kc/s :—

(i) by manual operation at all speeds up to at least 25 bauds without critical relay adjustment ; and

(ii) by means of an automatic keying device complying with the requirements of paragraph 5 of this Part of the Schedule ; and

(b) maintaining without adjustment of any control, a frequency tolerance throughout every transmission of :—

(i) plus or minus 0.5 per cent on a frequency of 500 kc/s ; and

(ii) plus or minus 0.02 per cent on a frequency of 8,364 kc/s.

(c) operation on full power within 30 seconds of being switched on.

(2) The carrier wave shall be modulated to a depth of 100 per cent by a wave of rectangular character so that the carrier is switched on for not less than 30 per cent and not more than 50 per cent of a modulation cycle.

(3) The note frequency shall not be less than 500 c/s and not more than 1,200 c/s.

(4) The power of the transmitter :—

(a) shall not be less than 15 metre-amperes on a frequency of 500 kc/s when determined in the manner prescribed by paragraph (3) of Rule 13 of these Rules ;

(b) shall not be less than 50 watts on a frequency of 500 kc/s, when measured into an artificial aerial consisting of a 30 ohm resistor in series with a capacitor of every value between 350 and 450 picofarads ; and

(c) shall not be less than 15 watts on a frequency of 8,364 kc/s when, measured into an artificial aerial simulating the impedance of the aerial specified in paragraph 2 of this Part of this Schedule.

(5) The transmitter shall be so designed and constructed that when it is adjusted for maximum power and the transmitting key is depressed the aerial may be disconnected or the output short-circuited without damage being caused to any part of the installation.

(6) There shall be provided :—

(a) an artificial aerial for testing the transmitter on full power, which shall include an indicator or lamp to indicate the passage of radio-frequency currents ; and

(b) an aerial ammeter, and a visual indicator to indicate the passage of radio frequency current, the failure of either of which shall not disconnect the aerial circuit.

5. AUTOMATIC TRANSMISSION.—(1) A device for automatic keying shall be provided as part of the radiotelegraph installation for lifeboats which when switched into circuit with the transmitter, shall be capable of automatically :—

(a) sending the alarm signal specified in sub-paragraph (2) of this paragraph immediately thereafter stopping and opening the keying circuit unless reset or re-wound ; and

(b)—(i) sending the distress call specified in sub-paragraph (3) of this paragraph in such manner that if the device is used without attention the transmission will be repeated once every twelve minutes until the source of electrical energy is exhausted ; and

- (ii) switching off the electrical energy to the transmitter in the silent interval between such transmissions and, so far as is necessary for the protection of the transmitter, automatically delaying the application of electrical energy after the device has been switched on.
- (2) The alarm signal shall consist of twelve four second dashes separated by one second spaces, the length of the dashes and spaces being maintained within a tolerance of plus or minus 0.2 second.
- (3) The distress call shall consist of the distress signal . . . — — — . . . repeated three times followed by a long dash, the characters of the distress signal being transmitted at a speed between 8 and 16 words inclusive per minute, and the duration of the long dash shall not be less than 20 seconds. The total length of the call shall not exceed 90 seconds.
- (4) Means shall be provided to ensure that, when the distress signal is sent, the transmission begins at the commencement of the signal within 40 seconds after the device for automatic keying has been switched into circuit.
- (5) The mechanism for keying the distress call specified in sub-paragraph (3) of this paragraph shall be such that it can be readily adapted to send a distress call consisting of the following signals in the following order :—
- the distress signal . . . — — — . . . three times ;
  - the morse characters for the word DE ;
  - the morse characters for the lifeboat's call sign three times ; and
  - a long dash having a duration of at least 20 seconds.
- The duration of the distress call shall not in that case be more than 90 seconds.
6. RECEIVER.—(1) The equipment shall include a receiver capable of :—
- receiving type A2 and type B waves ; and
  - being tuned over the frequency range 488 kc/s to 513 kc/s.
- (2) High frequency reception, if provided, shall be capable of receiving type A1 and type A2 waves on any frequency within the frequency band 8,266 kc/s to 8,745 kc/s.
- (3) The receiver shall be fitted with a manual gain control.
- (4) Headphones shall be provided and shall be shrouded to exclude noise.
- (5) The receiver shall comply with the requirements of sub-paragraph (6) to (9) inclusive, of this paragraph when tested in the following manner :—
- an artificial aerial shall be used and shall consist of a 40 ohm resistance in series with a two microhenry inductance and 100 picofarad capacitance ;
  - a type A2 signal shall, unless otherwise specified, be modulated to a depth of 30 per cent at 400 c/s ; and
  - the standard audio-frequency output shall be one milliwatt into a resistance substantially equal to the modulus of the impedance of the telephone receivers at 1,000 c/s.
- (6)—(a) The selectivity preceding the final detector of the receiver shall comply with the following requirements over the frequency range 488 kc/s to 513 kc/s :—
- not more than 6 decibels discrimination shall be obtained at frequency removed from tune by 1 kc/s ;
  - at least 6 decibels discrimination shall be obtained at frequencies removed from tune by 4 kc/s ;

(iii) at least 30 decibels discrimination shall be obtained at frequencies removed from tune by 20 kc/s ;

(iv) at least 60 decibels discrimination shall be obtained at frequencies removed from tune by 50 kc/s.

(b) In the case of a superheterodyne receiver, the image response ratio shall be at least 20 decibels.

(7) The sensitivity of the receiver shall be such that the standard audio-frequency output is obtained with an input not exceeding the following levels :

<i>Frequencies</i>	<i>Maximum input for type A1 waves</i>	<i>Maximum input for type A2 waves</i>
500 kc/s . . . .	does not apply	40 decibels above 1 microvolt.
8,364 kc/s (if provided)	30 decibels above 1 microvolt.	40 decibels above 1 microvolt.

(8) The signal/noise ratio shall, with the inputs and waves respectively specified in sub-paragraph (7) of this paragraph and with the rotary converter or vibrator running be not less than ;

(a) 15 decibels on a frequency of 500

(b) 25 decibels on a frequency of 8,364 kc/s (if provided.)

(9) The fidelity of the receiver shall be such that the change in level of the audio-frequency output shall be less than 8 decibels as the modulation frequency of the input signal is varied continuously from 300 c/s to 1,500 c/s for the level and modulation depth of the input signal being kept constant. For this purpose the input signal may have any level and depth of modulation provided the output of the receiver does not exceed the standard audio-frequency output.

7. CONNECTIONS WITH SHIP'S MAINS.—Any connections of the equipment with the ship's main source of energy shall be so provided as not to interfere with the launching of the lifeboat.

#### PART II.—PORTABLE EQUIPMENT

1. GENERAL.—(1) The portable radiotelegraph equipment for lifeboats (in this Part of this Schedule referred to as "the equipment") shall include a hand generator, a transmitter, a receiver and all other apparatus necessary for the operation of the equipment.

(2) Simple instructions for the operation of the equipment on the frequencies specified in sub-paragraph (1) of paragraph 5 of this Part of this Schedule shall be affixed in clear and permanent form, to the equipment.

(3) The equipment shall bear a removable plate on which shall be indicated in clear and permanent form the call sign of the lifeboat in letters and morse characters.

(4) For the purposes of the Fourth Schedule to these Rules the equipment shall be deemed to be Class X equipment. The immersion test specified in sub-paragraph (7) of paragraph 3 of the said Schedule shall be applied to the equipment when packed in the manner in which it will be stored on board ship.

2. DESIGN AND CONSTRUCTION.—The equipment shall be so designed and constructed that :—

(1) the entire equipment is contained in a single unit, provided that the mast referred to in sub-paragraph (2) of paragraph 3 of this Part of this Schedule may be attached to the single unit ;

(2) an unskilled person can erect the aerial system, and without difficulty and by simple operation and automatic means, can transmit the radiotelegraph signals specified in sub-paragraph (4) (a) of paragraph 5 of this Part of this Schedule ;

(3) the equipment is provided with handles and is readily portable by one person ;

(4) it is watertight and capable of floating in water ;

(5) it may be dropped from a height of 30 feet into water without damage ;

(6) it may be lowered into the sea or lifeboat from the boat deck ;

(7) it may be clamped to a lifeboat ;

(8) the number of manual controls are kept to the minimum required to meet the requirements of this Part of this Schedule, but include :—

(a) send/receive switching ;

(b) a switch for changing transmission from 500 kc/s to 8,364 kc/s and vice versa ;

(c) a switch position so that the transmitter valve filaments can be energised continuously whilst the receiver is energised ;

(d) a single control of receiver gain ;

(9) all manual controls are of such size as to permit normal adjustments to be made by a person wearing thick gloves ; and

(10) the operation of manual controls is not impeded by, and does not impede, the hand generation of electrical energy.

3. AERIAL AND EARTH SYSTEM.—The equipment shall include :—

(1) a single-wire aerial consisting of not less than 30 feet of high conductivity stranded or braided wire so fitted as to be capable of being supported from the lifeboat mast without the use of top-masts at the maximum practicable height ;

(2) a collapsible stayed mast capable of being easily and quickly stalled in a lifeboat and of supporting the aerial at a height of at least 16 feet above the sea when the base of the mast is resting on the bottom of any lifeboat in which it is intended to be used ; and

(3) an earth wire of high conductivity firmly connected to the equipment and loaded in such manner that the wire will sink when placed overboard.

4. HAND GENERATOR.—(1) The hand generator shall be of such design and construction that when the handle of the generator is rotated at any speed within the normal range of handle speeds :—

(a) sufficient electrical energy will be generated :—

(i) to enable the transmitter to comply with the requirements of sub-paragraph (4) (e) of paragraph 5 of this Part of this Schedule ; and

(ii) to enable the receiver to comply with the requirements of paragraph 6 of this Part of this Schedule ;

(b) the transmitter will comply with the requirements of sub-paragraph (4) (e) of paragraph 5 of this Part of this Schedule with a torque-speed at the handle of not more than 400 expressed in pounds-feet multiplied by revolutions per minute; and

(c) an indicator lamp will be lit, but will not be lit at any speed not within the normal range of handle speeds.

In this Part of this Schedule the expression "normal range of handle speeds" in relation to a generator means the range of speeds extending from the minimum speed at which the generator will enable the transmitter forming part of the same equipment to comply with the requirements of sub-paragraph (4) (e) of paragraph 5 of this Part of this Schedule to a speed at least 40 per cent greater than that speed.

(2) The hand generator shall be of such design and construction that:—

(a) it can be operated by:—

(i) one person; and

(ii) two persons simultaneously;

(b) the handles cannot be rotated in the wrong direction.

TRANSMITTER.—(1) The transmitter shall be capable of:—

(a) sending continuously, but not simultaneously, type A2 waves on the frequencies of 500 kc/s and 8,364 kc/s:—

(i) by manual operation at all speeds up to 16 bauds; and

(ii) by automatic means at the speeds specified in sub-paragraph (4) (a) of this paragraph;

(b) maintaining over the normal range of handle speeds throughout every transmission a frequency tolerance:—

(i) of plus or minus 0.5 per cent on a frequency of 500 kc/s

(ii) of plus or minus 0.02 per cent on a frequency of 8,364 kc/s; without adjustment of any control, and notwithstanding any variations of the impedance of the aerial or artificial aerial to which it is connected; and

(c) operating on full power, when the aerial system or artificial aerial has been connected and the necessary controls have been adjusted, within 30 seconds after the generation of electrical energy has commenced.

(2) The carrier wave shall be modulated to a depth of 100 per cent by a wave of rectangular character so that the carrier wave is switched on for not less than 30 per cent and not more than 50 per cent of a modulation cycle.

(3) The note frequency shall not be less than 450 c/s or more than 1,350 c/s.

(4) (a) The signal to be sent by the automatic means referred to in sub-paragraph (1) (a) of this paragraph:—

(i) when the transmission is on a frequency of 500 kc/s shall consist of the alarm signal of twelve four-second dashes separated by one-second spaces followed by the distress signal . . . — — — . . . repeated three times, and a long dash; and

(ii) when the transmission is on a frequency of 8,364 kc/s shall include the distress signal . . . — — — . . . repeated three times followed by a long dash of not less than 30 seconds duration.

- (b) Over the normal range of handle speeds :—
- (i) the speed of the automatic transmission of the distress signal shall be not less than 8 and not more than 15 words a minute ;
  - (ii) the tolerance in the timing of the dashes of the alarm signal shall not be more than plus or minus 0.2 seconds.
- (c) The automatic transmission shall cease and open the keying circuit after one complete transmission unless the mechanism is re-set or re-wound.
- (d) Means shall be provided :—
- (i) to ensure that the transmission begins at the commencement of the signal ;
  - (ii) to indicate to the operator that the mechanism should be re-set or re-wound.
- (e) The mean power developed by the transmitter in the load during a marking period, shall :—
- (i) on a frequency of 500 kc/s be not less than  $[(3.8 \log_{10} C) - 5.5]$  watts, C being the capacitance of the artificial aerial in picofarads, when measured with an artificial aerial consisting of a 15 ohm resistor in series with a capacitor having any value between the minimum capacitance of the aerial referred to in sub-paragraph (1) of paragraph 3 of this Part of this Schedule and 150 picofarads, and not less than 3.5 watts when measured with an artificial aerial consisting of a 30 ohm resistor in series with a capacitor having any value between 350 and 450 picofarads ;
  - (ii) on a frequency of 8,364 kc/s be not less than 3 watts when measured with an artificial aerial consisting of a 40 ohm resistor in series with any inductive or capacitated reactance in the range plus or minus 60 ohms.
- (f) The aerial circuit shall include :—
- (i) a tuning control suitable for use with all types of aerial provided, and
  - (ii) a tuning indicator, the failure of which shall not disconnect the aerial circuit,
- (g) There shall be provided :—
- (i) an artificial aerial within the equipment suitable for testing the transmitter on full power ;
  - (ii) means for testing the facilities for automatic transmission without the generation of radio-frequency energy.
- (5) The transmitter shall be so designed and constructed that when it is transmitting and adjusted for maximum power the aerial may be disconnected or the output short-circuited in either case without damage being caused to any part of the equipment.
6. Receiver.—(1) The receiver shall be a fixed tune receiver which shall be capable of receiving type A2 waves over the frequency band 490 to 510 kc/s when used with headphones.

(2) Headphones which are shrouded to exclude external noises shall be provided and shall be permanently attached to the receiver.

(3) The receiver shall comply with the requirements of sub-paragraph (4) of this paragraph when tested in the following manner :—

(a) artificial aerials shall be used and shall consist of either :—

(i) a 15 ohms resistor in series with a capacitor having any value between the minimum capacitance of the aerial referred to in sub-paragraph (1) of paragraph 3 of this Part of this Schedule and 150 picofarads, or

(ii) a 30 ohms resistor in series with a capacitor of any value within the range 350 to 450 picofarads ;

(b) the signals used shall be type A2 signals modulated to a depth of 30 per cent at 400 c/s.

(4) Over the normal range of handle speeds :—

(a) the standard audio-frequency output of the receiver into a resistance substantially equal to the modulus of the impedance of the telephone receivers at 1,000 c/s shall be one milliwatt ;

(b) the selectivity preceding the final detector of the receiver shall comply with the following table :—

Frequency	Requirement
490 to 510 kc/s .. .. .	Response to be uniform to within 6 decibels over the range. At least 40 decibels discrimination relative to the response at 500 kc/s to be obtained at all frequencies.
Below 460 kc/s .. .. .	
Above 540 kc/s .. .. .	

(c) the audio-frequency response of the receiver shall be uniform to within 6 decibels over the range of modulation frequencies 400 to 1,400 c/s and shall substantially fall for frequencies outside this range ;

(d) the standard output specified in sub-paragraph (a) shall be obtained with a test signal input not exceeding 40 decibels above one microvolt on a frequency of 500 kc/s ;

(e) with the test signal specified in sub-paragraph (d) the signal/noise ratio shall be at least 15 decibels.

## SIXTH SCHEDULE

(Rule 15)

### TOOLS, MEASURING INSTRUMENTS, SPARE PARTS, ETC.

#### PART I—TOOLS

- 1 contact burnisher ;
- 1 6 in. smooth file ;
- 1 jointing knife ;
- 1 pair 7 in. wireman's insulated pliers ;
- 1 pair 6 in. long nose pliers with side cutters ;
- 1 insulated screwdriver, not less than 8 in. in length, with  $\frac{1}{4}$  in. blade ;

- 1 insulated grub screwdriver with  $\frac{1}{8}$  in. blade ;
- 1 watch screwdriver with  $\frac{1}{16}$  in. blade ;
- 1 set of spanners, sizes 0, 2, 4, and 6B.A. ;
- 1 spanner adjustable to 1 in. nuts ;
- 1  $\frac{1}{4}$  in. hand drill ;
- 1 set of high-speed twist drills, sizes  $\frac{3}{16}$  in., 26, 34 and 44 ;
- 1 clamp vice ;
- 1 electric soldering iron to suit ship's voltage with a power consumption of not less than 40 watts or more than 70 watts ;
- 1 dusting brush ;
- 1  $\frac{1}{2}$  lb. ball-pane hammer ;
- A tool box or compartment for containing the foregoing tools and capable of being locked.

#### PART II.—MEASURING INSTRUMENTS

- 1 hydrometer ;
- 1 dipping fahrenheit thermometer ;
- An ammeter capable of measuring direct current from 1 milliampere to 500 milliamperes ; a voltmeter capable of measuring current voltage from 75 millivolts to 500 volts and alternating capable of measuring from 150 millivolts to 500 volts ; and an ohm-meter capable of measuring resistance from 10 ohms to 20,000 ohms ; provided that a measuring instrument in which the requirements for an ammeter, a voltmeter and an ohm-meter specified above are combined may be substituted for the said instruments.

#### PART III.—SPARE PARTS AND SPARE EQUIPMENT

- 1 set of brushes for each machine installed ;
- 2 cartridges for each cartridge fuse in use ;
- 1 set of key contacts for each type of key in use ;
- 1 main aerial made up (wire only) ;
- 50 per cent of the number of insulators in use (excluding leading insulators) ;
- 100 per cent of the number of shackles and thimbles in use ;
- 12 bulldog grips to suit the aerial wire ;
- 1 set of telephones and leads (with plugs if used) for each type of telephone lead in use ;
- 1 valve for each two of the first six of each type of valve in use and then 1 valve for each additional 3 valves or part of 3 valves of that type in use
- 3 vibrators for each type of vibrator in use ;
- 1 indicator lamp for each indicator lamp in use ;
- 6 mica discs for spark gap } If used in the radiotelegraph installation ;
- 1 pressure disc
- 1 emergency lamp ;
- 1 charging mat if a mat-type charging unit is in use ;
- 2 charging lamps for each type of charging lamp in use ;
- 1 rectifier if a rectifier-type charging unit is in use.

#### PART IV.—MISCELLANEOUS ITEMS

- 4 ozs. petroleum jelly ;
- 3 sheets glass paper ;
- 8 ozs. resin-cored solder ;
- 4 ozs. insulating tape ;

- $\frac{1}{2}$  pint lubricating oil ;
- $\frac{1}{2}$  lb. grease suitable for machine in use ;
- $\frac{1}{4}$  ozs assorted fuse wire, 1 ampere, 5 ampere and 15 ampere ;
- 1 length of aerial wire equal to the length of the emergency aerial plus 10 feet (uncut) ;
- 6 yards flexible wire (5 amperes) for adjustable connections ;
- 4 ozs, copper binding wire ;
- 4 ozs. trichloroethylene.

\* These items need not be provided in ships other than those engaged on international voyages.

## SEVENTH SCHEDULE

(Rule. 17)

### AUTO-ALARM

1. GENERAL.—(1) The auto-alarm shall :—
- (a) include a receiver, a selector, a test signal generator and an audible alarm system ;
  - (b) be capable of giving audible warning of the receipt of an alarm signal consisting of a series of 12 consecutive dashes, each with a duration of 4 seconds and separated by intervals of one second in each case subject to the tolerances specified in paragraph 3 of this Schedule ;
  - (c) be capable of being rapidly connected with the main aerial referred to in Rule 12 of these Rules or to an equally efficient aerial ;
  - (d) comply with the requirements of this Schedule notwithstanding variations of the supply voltage of :—
    - (i) plus 5 per cent or minus 10 per cent if the equipment is operated from the emergency source of electrical energy required by paragraph (2) of Rule 14 of these Rules or from batteries ; or
    - (ii) plus or minus 10 per cent if the equipment is operated from the main source of electrical energy required by paragraph (1) of the said Rule.
- (2) The receiver, selector and test signal generator shall be installed in a radiotelegraph room.
- (3) The auto-alarm shall be provided with a switch or system of switches by which it may be connected to the ship's main aerial or to an equally efficient aerial ; or
- (4) The auto-alarm shall include a manual re-setting device to enable the selector to be re-set after the audible alarm system has been actuated.
2. RECEIVER.—(1) The receiver forming part of the auto-alarm shall be capable of receiving type A2 waves and type B waves in each case on all note frequencies between 400 c/s and 1,400 c/s and on all carrier waves of a frequency between 492 kc/s to 508 kc/s.
- (2) All tuning controls and gain controls which affect the operation of the receiver as part of the auto-alarm shall be pre-set and shall not be capable of operation from the outside of the auto-alarm.

(3) The receiver shall comply with the requirements of sub-paragraphs (4) to (7), inclusive, of this paragraph when tested in the following manner, except where another method of testing is specified in the said sub-paragraphs :—

(a) an artificial aerial shall be used for the test and shall consist of a 10 ohm resistor in series with a capacitor having any value between 300 and 750 picofarads ;

(b) type A2 signals used in the test shall be modulated to a depth of 70 per cent and shall have a note frequency of 400 c/s ;

(4) The selectivity of the receiver shall be such that :—

(a) the radio-frequency response is uniform to within 3 decibels in a frequency range 492 to 508 kc/s ;

(b) the total variation of audio-frequency response is not more than 3 decibels in the case of note frequencies in the range 400 to 1,400 c/s ;

(c) the audio-frequency response falls rapidly in the case of note frequencies below 400 c/s and above 1,400 c/s ; and

(d) the auto-alarm gives response to an alarm signal of a frequency of 500 kc/s and an input level of 40 decibels above one microvolt, in the presence of another signal having the following characteristics ;

Type of wave	Modulation frequency	Depth of modulation	Carrier frequency	Input Level (decibels about one microvolt)
Continuously modulated	All audio-frequencies in the range 50 c/s to 1,400 c/s	70 per cent	Below 470 kc/s and above 530 kc/s	80
			Below 450 kc/s and above 550 kc/s	120

(5)—(a) The sensitivity of the receiver shall for the purposes of this paragraph, be taken to be the minimum input level of the test alarm signal injected at a frequency of 500 kc/s which will operate the selector. The sensitivity of the receiver shall be such that the selector will operate by the injection of an alarm signal from the test signal generator forming part of the auto-alarm.

(b) The receiver shall be provided with an automatic gain control which shall :—

(i) during periods when the selector is continuously in operation, steadily reduce the sensitivity of the receiver at a rate within the range 7.5 to 15 decibels per minute in the case of a range of sensitivity of 40 to 80 decibels above one microvolt notwithstanding that the input level of an injected signal is at any level above the minimum necessary to operate the selector ;

(ii) during periods when the selector is not continuously in operation steadily increase the sensitivity of the receiver to a maximum level of between 35 and 40 decibels above one microvolt at a range of sensitivity of 40 to 80 decibels above one microvolt notwithstanding that the input level of an injected signal is at any level below the level corresponding to the threshold of selector release.

(6) The automatic gain control when morse interference is simulated by continuous keying of a test signal of a frequency of 500 kc/s and an input level of 100 decibels above one microvolt with a mark-to-space ratio of 19 to 1, and variation of frequency of interruption is obtained by varying the speed of transmission, shall be such that :—

(a) when such test signal produces three interruptions per second, the sensitivity of the receiver is not reduced below that necessary for the reception of a signal of an input level of 40 decibels above one microvolt ; and

(b) when the speed of such test signal is arranged so that there are three interruptions per period of 2 seconds the sensitivity of the receiver is so reduced after operating for a period of 15 minutes that a signal of at least 70 decibels above one microvolt is required to operate the selector.

(7) If, in addition to the automatic gain control, a pre-set manual control of receiver gain is provided the range of sensitivity variations provided by that control shall be not more than 10 decibels.

(8) The receiver shall be such that the auto-alarm will respond to a test alarm signal transmitted on any frequency in the range 492 kc/s to 508 kc/s and at an input level of 50 decibels above one microvolt in the presence of an interfering signal with the following characteristics :—

Type of signal	Depth of modulation	Modulation frequency	Input level	Speed of transmission
Type A2. .	70 per cent	400 c/s- 1,400 c/s	120 decibels above one microvolt	15-40 words transmission

(9) The receiver shall be such that it will not operate the selector upon the simultaneous injection of any two continuous carrier waves of which the frequency difference or sum falls within the range 492 kc/s, being waves with the following characteristics :—

Frequency	Input level	Modulation
Outside the range 450 kc/s to 550 kc/s	120 decibels above one mi- crovolt	One unmodulated and the other modulated to a depth of 70 per cent at any audio-fre- quency in the range 400 c/s to 1,400 c/s.

(10)—(a) The receiver shall not in normal service produce a field exceeding 0.1 microvolt per metre when measured at a distance of one mile from the receiver, unless the test signal generator is in operation.

(b) The receiver shall be deemed to comply with the requirements of sub-paragraph (a) of this paragraph if, when :—

(i) the receiver is placed centrally in a screened earthed enclosure of dimensions at least 6 feet cube ;

(ii) the earth terminal of the receiver is connected to the inside of the screen ;

(iii) the aerial terminal of the receiver is connected through an un-screened search coil situated within the said enclosure and of dimensions one foot square and an un-screened lead to a resistive measuring instrument mounted outside the enclosure and having its other terminal earthed ; and

(iv) the receiver is energised,

the power measured by the measuring instrument does not exceed  $4 \times 10^{-10}$  watts whatever the resistance of the measuring instrument or the adjustment of the receiver, and notwithstanding that the search coil is short-circuited or moved in any way without approaching within 6 inches of the receiver case.

3. SELECTOR—(1) The selector, in conjunction with the receiver shall be capable of :—

(a) accepting :—

(i) dashes of a duration within the tolerances 3.5 to 6.0 seconds

(ii) spaces between dashes being spaces of a duration within the tolerances 0.01 to 1.5 seconds ; and

(b) rejecting :—

(i) dashes of a duration of less than 3.4 seconds ;

(ii) dashes of a duration of more than 6.2 seconds ; and

(iii) spaces between dashes, being spaces of a duration of more than 1.6 seconds.

(2) The selector, after accepting three or four consecutive dashes of the alarm signal, shall actuate the audible alarm system.

(3) Any timing controls provided as part of the selector shall be pre-set and shall not be capable of being operated from the outside of the equipment.

4. TEST SIGNAL GENERATOR.—(1) The test signal generator shall be capable of :—

(a) generating, for purposes of test, a signal with the following characteristics :—

(i) Frequency—500 kc/s ;

(ii) Type of wave—A2.

(iii) Depth of modulation—within the range 70 to 100 per cent.

(iv) Modulation frequency—within the range 400 to 1,400 c/s ;

(v) Input level—equivalent to a voltage modulated to a depth of 70 per cent within the range 37 to 43 decibels above one microvolt in series with the artificial aerial ; and

(b) injecting into the receiver the alarm signal specified in paragraph 1 (b) of this Schedule within the tolerances specified in sub-paragraph (1) (a) of paragraph 3 of this Schedule and the characteristics specified in the foregoing provisions of this paragraph, both by means of:—

- (i) a manual key of a non-locking type, and
- (ii) the automatic keying device specified in Part V of the Second Schedule to these Rules.

(2) The method of injection shall be such that the test alarm signal will not operate the audible alarm system when the aerial is disconnected.

(3) The test signal generator shall be so designed and constructed that the input level of the signal specified in sub-paragraph (1) (a) of this paragraph can be increased by approximately 20 decibels by means of a non-locking switch.

5. AUDIBLE ALARM SYSTEM.—(1) The audible alarm system shall consist of three alarm bells installed respectively in a radiotelegraph room, on the bridge and in the sleeping room of a radio officer. The bells shall be operated from the source of electrical energy required by paragraph (2) of Rule 14 of these Rules by means of a power circuit taken from an unfused circuit, and so fused that the efficiency of the audible alarm system will not be affected by the rupture of any fuse other than a fuse forming part of that system. The power circuit shall be controlled by a locking switch situated on or near to the receiver forming part of the auto-alarm, and clearly and permanently marked to indicate its purpose.

(2) Subject to the provisions of sub-paragraph (3) of this paragraph the alarm bells shall, whenever the auto-alarm is in operation as such, give an alarm:—

(a) when actuated by the selector; and

(b) within 15 seconds after any failure for 9 seconds (subject to tolerance plus or minus 6 seconds) of:—

(i) the direct-current voltage feeding the anode of any valve of the receiver forming part of the auto-alarm, if the receiver is not provided with a vibrator;

(ii) any vibrator forming part of the receiver;

(iii) a circuit of a filament of any directly-heated valve forming part of the receiver if it is operated from the main source of electrical energy required by paragraph (1) of Rule 14 of these Rules; and

(iv) any continuously rotating mechanism forming part of a selector operated from the said main source of electrical energy;

(c) within 15 seconds after any failure of:—

(i) a circuit of a filament of a directly-heated valve forming part of the receiver if it is operated from batteries;

(ii) any continuously rotating mechanism forming part of a selector operated from batteries.

(3) A device shall be provided which will enable the bells situated on the bridge to be disconnected from the aforesaid power circuit. The device may include means for so disconnecting the bell situated in the radio officer's sleeping room. The device shall be non-locking, and shall not be capable of disconnecting the bell in the radiotelegraph room. The device shall be clearly and permanently marked to indicate its purpose.

6. FIELD TEST.—If the auto-alarm is in operation for a period of 28 days in connection with an aerial having an effective height of not less than 10 metres and situated at any point within 3 miles of the coast of Nigeria the auto-alarm shall not be actuated during that period by signals other than :—

- (a) signals locally generated to test the auto-alarm ; and
- (b) signals within the tolerances specified in sub-paragraph (1) (a) of paragraph 3 of this Schedule.

7. AUTO-ALARM USED AS AN EMERGENCY RADIOTELEGRAPH RECEIVER.—If the auto-alarm is intended to be used as an emergency radiotelegraph receiver it shall, in addition to complying with the foregoing requirements of this Schedule, comply with the following requirements :—

(1) The receiver forming part of an auto-alarm shall be capable of :—

- (a) headphone reception and loudspeaker reception of the waves specified in sub-paragraph (1) of paragraph 2 of this Schedule ;
- (b) operation from :—
  - (i) the main source of electrical energy required by paragraph (1) of Rule 14 of these Rules ; and
  - (ii) the emergency source of electrical energy required by paragraph (2) of Rule 14 of these Rules ;

(2) The receiver shall be provided with :—

- (a) a built-in switch for changing operation of the receiver from the main source of electrical energy to the emergency source of electrical energy ; and
- (b) a manual gain control so arranged that the performance of the auto-alarm as such is not impaired at any setting of the control.

(3) The standard audio-frequency output level of the receiver shall be :—

- (a) for headphone reception, 10 decibels below one milliwatt into a resistance substantially equal to the modulus of the impedance of the telephone receivers at 1,00 c/s ; and
- (b) for loud-speaker reception, 17 decibels above one milliwatt into a resistance which loads the output valve with the load appropriate to the valve.

(4) The sensitivity of the receiver shall be such that when measured with a signal interrupted in the manner specified in sub-paragraph (6) (a) of paragraph 2 of this Schedule and modulated to a depth of 30 per cent the standard audio-frequency output level shall be obtained with a signal input not exceeding 40 decibels above one microvolt.

(5) When the manual gain control is adjusted to give the standard audio-frequency output of the receiver with the signal input specified in sub-paragraph (4) of this paragraph, the signal/noise ratio shall be at least 20 decibels.

(6) The receiver shall comply with sub-paragraph (10) of paragraph 2 of this Schedule when used with unscreened headphones.

## EIGHTH SCHEDULE

(Rules 19 &amp; 28)

## TABLE OF WATCH HOURS

Zones (1)	Western Limits (2)	Eastern Limits (3)	Hours of Watch (Greenwich Mean Time)	
			16 hours (4)	8 hours (5)
A.—Eastern Atlantic Ocean	Meridian of 30°W., Coast of Greenland.	Meridian of 30° E., to the South of the Coast of Africa, Eastern limits of the Mediter- ranean, of the Baltic, 30°E. to the North of Norway.	<i>From To</i> 0h. 6h. 8h. 14h. 16h. 18h. 20h. 22h.	<i>From To</i> 8h. 10h. 12h. 14h. 16h. 18h. 20h. 22h.
B.—Western Indian Ocean Eastern Arctic Sea	Eastern Limit of Zone A.	Meridian of 80° E., West Coast of Ceylon to Adams Bridge thence west- ward round the coast of India	0h. 2h. 4h. 10h. 12h. 14h. 16h. 18h. 20h. 24h.	4h. 6h. 8h. 10h. 12h. 14h. 16h. 18h.
C.—Eastern Indian Ocean, China Sea, Western Pacific Ocean	Eastern Limit of Zone B.	Meridian of 160° E.	0h. 6h. 8h. 10h. 12h. 14h. 16h. 22h.	0h. 2h. 4h. 6h. 8h. 10h. 12h. 14h.
D.—Central Pacific Ocean	Eastern Limit of Zone C.	Meridian of 140° W.	0h. 2h. 4h. 6h. 8h. 10h. 12h. 18h. 20h. 24h.	0h. 2h. 4h. 6h. 8h. 10h. 20h. 22h.
E.—Eastern Pacific Ocean	Eastern Limit Zone D.	Meridian of 90° W. as far as the Coast of Central America then the West Coast of Central America and North America.	0h. 2h. 4h. 6h. 8h. 10h. 16h. 22h.	0h. 2h. 4h. 6h. 16h. 18h. 20h. 22h.
F.—Western Atlantic Ocean and Gulf of Mexico	Meridian of 90° W., Gulf of Mexico, East Coast of North America.	Meridian of 30° W., Coast of Greenland	0h. 2h. 4h. 10h. 12h. 18h. 20h. 22h.	0h. 2h. 12h. 14h. 16h. 18h. 20h. 22h.

**NINTH SCHEDULE**  
**FORM OF RADIOTELEGRAPH LOG-BOOK**  
**RADIOTELEGRAPH LOG**  
**PART I**

Name of Ship	Official Number and International Call Sign	Port of Registry	Gross Tonnage

Name of Company operating the Radio Service.....

Port at which and date when voyage commenced	Nature of the voyage or employment	Port at which and date when voyage terminated
Date ..... Port .....		Date ..... Port .....

Delivered to the Superintendent of the Mercantile Marine Office at the  
 Port of ..... on the ..... day,  
 ..... 19..... together with Radiotelegraph  
 Log Part II, serial numbers ..... to.....  
 ..... Countersigned ..... Master  
 ..... Superintendent ..... Address

**SECTION A—PARTICULARS OF RADIO STAFF**

Name	Home Address	Certificate Number and class

## SECTION B—PARTICULARS OF BATTERIES ON BOARD

Battery Number	Number of	Type	Date Supplied	Voltage and Ampere-hour	Purpose for which used

## SECTION C—DAILY EXAMINATION OF BATTERIES

Date	Battery Number	Voltage off Load	Voltage on Load	Remarks

## SECTION D—MONTHLY REPORT OF BATTERIES

Date	Battery Number and Cell Number	Specific Gravity as measured		Remarks	Date	Battery Number and Cell Number	Specific Gravity as measured		Remarks
		Before charge	After charge				before charge	after charge	

RADIOTELEGRAPH LOG  
PART II

Name of Ship	Official Number and International Call Sign	Port of Registry	Gross Tonnage

Serial Number ..... from ..... to .....

Name of Company operating the Radio Service .....

S.S. ....  
M.V. ....

## DIARY OF THE RADIOTELEGRAPH SERVICE

<i>Date and Time (G.M.T.)</i>	<i>Station From</i>	<i>Station To</i>	<i>Full Details of Calls, Signals and Distress Working as prescribed by Rule 22</i>	<i>Frequency</i>

(Rule 30)

## TENTH SCHEDULE

FORM OF RADIOTELEPHONE LOG BOOK  
RADIOTELEPHONE LOG

<i>Name of Ship</i>	<i>Official Number</i>	<i>Port of Registry</i>	<i>Gross Tonnage</i>

Name of Company operating the Radio Service.....

period covered by Log—From ..... To.....  
Delivered to the Superintendent of the Mercantile Marine Office at the

Port of ..... on the ..... day of.....

..... 19.....  
Countersigned ..... Master

..... Superintendent ..... Address

## SECTION A—PARTICULARS OF RADIOTELEPHONE OPERATORS

<i>Name</i>	<i>Home Address</i>	<i>Certificate Number and Class</i>

S.S. ....  
M.V. ....

## SECTION B—DIARY OF THE RADIOTELEPHONE SERVICE

<i>Date and Time (G.M.T.)</i>	<i>Station From</i>	<i>Station To</i>	<i>Frequency Used</i>	<i>Record of Working, as prescribed by Rule 30</i>

## ELEVENTH SCHEDULE (Rule 1 (5))

## DIRECTION-FINDER

## TRANSITIONAL PROVISIONS

1. Any ship which is provided with a direction-finder which was installed in the ship before 19th November, 1954 shall not be required to comply with the requirements of Rules 35 and 36 of these Rules if the direction finder—

(a) complies with such of the requirements of the United Kingdom Merchant Shipping (Wireless Telegraphy) Rules, 1938, as would have been applicable to it had the said Rules not been revoked, and

(b) is capable of

(i) receiving type A1, A2 and B waves on all frequencies from 255 kc/s to 525 kc/s; and

(ii) taking radio bearings when the field strength at the loop aerial system is as low as 50 microvolts per metre.

## TWELFTH SCHEDULE (Rule 3)

## DIRECTION-FINDER EQUIPMENT

1. GENERAL.—The direction-finder shall include a receiver and a loop aerial system. For the purposes of this Schedule (except paragraph 10 (2) thereof) any goniometer forming part of the direction-finder shall be deemed to be part of the loop aerial system. The loop aerial system other than ball bearings, hose clips, set screws and other similar small parts, shall consist of non-magnetic material.

2. CAPABILITY.—The direction-finder shall be capable of headphone reception of waves of type A1, type A2 and type B of any frequency within the range of 255 kc/s to 525 kc/s so as to enable the radio bearing and sense of the signal to be determined by reference to the minimum strength thereof.

3. CONTROLS.—The receiver shall be provided with

(1) a radio-frequency gain control;

(2) a tuning control;

(3) a tuning scale in which, at no point in the running range, an interval of  $\frac{1}{8}$  inch corresponds to a frequency change of more than 8 kc/s.

4. GENERAL METHOD OF TESTING.—The receiver shall comply with the requirements of paragraphs 5 to 12 inclusive, and 16 of this Schedule when tested in the following manner on any frequency within the range 255 kc/s to 525 kc/s :—

(1) Signals (in this Schedule referred to as "locally generated signals") shall be obtained from one or more signal generators.

(2) Locally generated signals shall be injected through a network in such manner that the signal generator or generators, as the case may be, and the network are together equivalent to a constant voltage generator in series with an impedance substantially equal to the impedance of the loop aerial system at the test frequency, when

(a) the loop aerial system is adjusted for the determination of radio bearings;

- (b) the sense-finder is not in operation ; and  
 (c) the impedance is measured between the two terminals to which the receiver is normally connected.
- (3) The effective height ( $h_e$ ) in metres of the loop aerial system shall be the ratio  $E/e$ , where  $E$  is the voltage produced by a vertically polarised field of strength  $e$  volts per metre, when
- (a) the loop aerial system is adjusted for the determination of bearings and for maximum pick-up ;  
 (b) the sense-finder is not in operation ;  
 (c) the receiver is not connected to the loop aerial system and  
 (d) the voltage is measured between the terminals of the loop aerial system to which the receiver is normally connected.
- (4) The standard input level shall be the input level obtained when the electromotive force of the equivalent signal generator referred to in sub-paragraph (2) of this paragraph is 50  $h_e$  microvolts root mean square.
- (5) The standard output level shall be an audio-frequency output of one milliwatt into a resistance substantially equal to the modulus of the impedance of the telephone receivers at 1,000 c/s.
- (6) The signal-noise ratio of the direction-finder shall be determined either

(a) by using vertically polarised waves for transmission of the input signals, and with the loop aerial system arranged for the determination of bearings and adjusted for maximum pick-up without the sense-finder in operation or

(b) by using locally generated signals applied to the receiver only in the manner specified in sub-paragraph (2) of this paragraph.

5. SIGNAL AND INTERMEDIATE FREQUENCY SELECTIVITY.—The signal frequency selectivity of the receiver, or in the case of a superheterodyne receiver the signal and intermediate frequency selectivity shall satisfy the following requirements :—

(a) The minimum bandwidth for 6 decibels discrimination shall be as 2 kc/s.

(b) The maximum bandwidth in relation to discrimination shall be as follows :—

Discrimination	30 decibels	60 decibels	90 decibels
Bandwidth	8 kc/s	16 kc/s	35 kc/s

At any frequency outside the bandwidth of 35kc/s specified in (b) the discrimination shall not be less than 90 decibels except in the case of superheterodyne receivers, where at the image frequency the discrimination shall not be less than 80 decibels.

## 6. GAIN.—When

(a) the input terminals of the receiver are closed solely through an external impedance substantially equal to that of the loop aerial system at the test frequency,

(b) the sense-finder is not in operation and

(c) impedance is measured between the two terminals of the loop aerial system to which the receiver is normally connected,

the gain of the receiver shall be such that receiver noise can produce an output level of minus 10 decibels relative to the standard output level at any frequency within the range of frequencies specified in paragraph 2 of this Schedule.

## 7. SIGNAL/NOISE RATIO.—

## (1) When

(a) the note filter (if any) is switched out of circuit,

(b) a type A1 signal is injected at the standard input level and

(c) the receiver gain is manually adjusted to give the standard output level, the signal/noise ratio shall not be less than 20 decibels.

## (2) When

(a) the note filter (if any) is switched out of circuit,

(b) a type A2 signal modulated to a depth of 30 per cent., with a note frequency of 400 c/s is injected at the standard input level, and

(c) the receiver gain is manually adjusted to give the standard output level, the signal/noise ratio shall not be less than 10 decibels.

(3) For the purposes of this paragraph spurious whistles shall be regarded as noise.

8. BLOCKING.—The change in output of the receiver shall not exceed 3 decibels at any frequency within the range of frequencies specified in paragraph 2 of this Schedule, and at all levels of wanted signal up to 50 decibels above the standard input level, whether of type A1 or type A2, when locally generated signals of type A1 or type A2 at a level of 40 decibels above the level of the wanted signal and spaced 10 kc/s from the carrier of the wanted signal are applied.

9. INTERMODULATION.—The input level of two unwanted signals shall not be less than plus 75 decibels relative to the standard input level when

(a) the receiver is adjusted to give standard output level with a locally generated wanted signal of standard output level modulated to a depth of 30 per cent., with a note frequency of 400 c/s at any frequency within the range of frequencies specified in paragraph 2 of this Schedule ;

(b) the input wanted signal has been removed ; and

(c) two unwanted locally generated signals each of any frequency which is not less than 50 kc/s from the frequency of the wanted signal but whose frequency sum or frequency difference is equal to the frequency of the wanted signals, one signal being modulated to a depth of 30 per cent. with a note frequency of 400 c/s and the other signal being unmodulated, are simultaneously applied at equal input levels so as to give an output equal to that previously obtained with the wanted signals.

10. RADIATION.—(1) The direction-finder shall not in normal service produce a field exceeding 0.1 microvolt per metre when measured at a distance of one mile from the receiver.

(2) The receiver, including the goniometer, if any, shall be deemed to comply with the requirement of sub-paragraph (1) of this paragraph if, when

(a) the receiver without the aerial system is placed centrally in a screened earthed enclosure of dimensions at least six feet cube,

(b) the earth terminal is connected to the inside of the screen,

(c) each aerial terminal in turn is connected through an unscreened four-turn rectangular search coil situated within the said enclosure and of dimensions one foot square and an unscreened lead to a resistive measuring instrument mounted outside the enclosure, having its other terminal earthed;

(d) the aerial terminal or terminals of the receiver, other than the terminal connected to the aforesaid measuring instrument, are earthed one at a time or in any combination or remain unearthed or are interconnected in any combination and

(e) the receiver is energised and unscreened headphones are connected thereto,

the power measured by the said measuring instrument when connected in the manner specified in (c) of this paragraph, does not exceed  $4 \times 10^{-10}$  watts whatever the resistance of the measuring instrument or the adjustment of the receiver notwithstanding that the search coil be short-circuited or moved in any way provided that it does not approach within 6 inches of the receiver case.

11. TUNING DRIFT AND STABILITY.—(1) After the receiver has been switched on for 5 minutes and tuned to any frequency within the frequency range specified in paragraph 2 of this Schedule the tune frequency shall not change by more than one part in one thousand in any period of 5 minutes.

(2) a change of 5 per cent in any one of the supply voltages to the receiver, or to a power unit associated therewith, shall not cause the tune frequency to change by more than three parts in ten thousand; and

(3) a change of ambient temperature of  $5^{\circ}\text{C}$  within the range of  $0^{\circ}\text{C}$  to  $50^{\circ}\text{C}$  applied after the receiver has been switched on for one hour shall not cause the tune frequency to change by more than one in one thousand.

12. HETERODYNE NOTE STABILITY.—The heterodyne note stability of the receiver shall be such that

(1) the frequency of a heterodyne note which is initially one kilocycle per second shall not vary by more than 100 c/s when an input signal is increased over the range of levels from 0 to 60 decibels above the standard input; and

(2) at all input levels within the range specified in sub-paragraph (1) of this paragraph a beat note of 200 c/s can be obtained by tuning either towards or away from zero beat.

13. ACCURACY OF BEARINGS.—When the direction-finder is tested using type A2 waves modulated to a depth of from 80 per cent to 100 per cent and with a vertically polarised field having a level of 40 decibels relative to one

microvolt per metre, the bearings indicated by the scale of the direction-finder shall, at all frequencies in the range of frequencies specified in paragraph 2 of this Schedule, throughout the whole 360 degrees of azimuth and after due allowance has been made for any site errors, be correct within plus or minus one degree of the true bearing.

14. QUALITY OF MINIMA.—When the direction-finder is arranged for the taking of bearings and is tested under the conditions specified in paragraph 13 of this Schedule, but with a field strength sufficient to give a signal/noise ratio of at least 50 decibels with the loop aerial system adjusted for maximum output, changes in the setting of the bearing indicator 5 degrees and 90 degrees in either directions from the position or positions of minimum output shall, at all frequencies in the range of frequencies specified in paragraph 2 of this Schedule, cause the audio-frequency output to increase by not less than 18 decibels and not less than 35 decibels respectively.

15. EFFICIENCY OF SENSE-FINDER. When

(a) the equipment is adjusted for the determination of sense and is tested under the conditions specified in paragraph 13 of this Schedule but with a field strength sufficient to give a signal noise ratio of at least 50 decibels with the loop aerial system adjusted for maximum output, and

(b) the sense indicator is adjusted to indicate any bearing within plus or minus 10 degrees of the true bearing,  
the audio-frequency output level of the receiver due to the wanted signal shall be at least 20 decibels below the output level that is obtained when the sense indicator is adjusted to indicate any bearing within  $180 \pm 10$  degrees of the true bearing.

16. FIDELITY.—The maximum change in level of the output of the receiver shall be less than 8 decibels when the modulation frequency of an input signal of constant level and modulation depth is varied continuously from 300 c/s to 1,500 c/s. For the purposes of this paragraph the output of the receiver shall not exceed the standard output level and the input signal shall be applied at any level in the range from the standard input level to 50 decibels above that level.

### THIRTEENTH SCHEDULE

(Rule 4)

#### DIRECTION-FINDING EQUIPMENT CLIMATIC AND DURABILITY TESTS

1. In this Schedule :

(1) References to Class B equipment shall be construed as references to each part of the direction-finder other than the loop aerial system.

(2) References to Class X equipment shall be construed as references to the loop aerial system.

2. The tests referred to in paragraphs 2 to 10 inclusive of the fourth Schedule to these Rules shall apply to direction-finding equipment.

TABLE

Nature of Test							Class of Equipment
(1) Vibration test .. .. .	..	..	..	..	..	..	B X
(2) Bump test .. .. .	..	..	..	..	..	..	B X
(3) Dry heat test .. .. .	..	..	..	..	..	..	B X
(4) Damp heat test .. .. .	..	..	..	..	..	..	B X
(5) Low temperature test .. .. .	..	..	..	..	..	..	B X
(6) Rain test .. .. .	..	..	..	..	..	..	X
(7) Immersion test .. .. .	..	..	..	..	..	..	X
(8) Corrosion test—salt water .. .. .	..	..	..	..	..	..	B X
(9) Corrosion test—acid fumes (if a battery is included in the equipment) .. .. .	..	..	..	..	..	..	B X
(10) Mould growth test .. .. .	..	..	..	..	..	..	X

FOURTEENTH SCHEDULE (Rule 13 (c))

CERTIFICATE OF CALIBRATION OF DIRECTION-FINDER

We, the undersigned, hereby certify that we have this day  
 (a) calibrated in accordance with the Merchant Shipping (Direction-

Finders) Rules, 1964 the direction-finder installed in the s.s./M.v.....

(b) handed to the Master of that ship tables of calibration corrections.

(c) adjusted the said direction-finder so that the readings taken thereby, when corrected with such tables differed from the correct bearings by no more than plus or minus two degrees.

We hereby further certify that the Master of the said ship has been furnished with a list or diagram indicating the conditions, and position, at the time of such calibration, of the aerials and of all moveable structures on board the ship which might effect the accuracy of the direction-finder.

.....Radio Observer

.....Visual Observer

.....Date

## FIFTEENTH SCHEDULE

## RECORD OF CHECK-BEARINGS TAKEN BY MEANS OF THE DIRECTION-FINDER

(Rule 13 (d))

(1)	Serial Number of Bearings	
(2)	Date	
(3)	Times (G.M.T.)	
(4)	Latitude	Ship's Approximate Position
	Longitude	
(9)	Distance from Transmitter	
(7)	Direction-Finder Bearing of (Name)	
(8)	Direction-Finder relative Bearing Corrected for Q.E.	
(6)	Ship's Head by Compass 0/360°	
(10)	Total Compass Error	
(11)	‡ Conveygency Applied	
(12)	Ship's Head Corrected (True)	
(13)	True Bearing by Direction-Finder [Col. (8) and Col. (12) ]	
(14)	True Bearing by Calculation or by Visual check (whether calculated or Visual to be indicated)	
(15)	Correction required to make Col. (13) equal Col. (14) (indicating whether - or +)	
(16)	Signature of Observer or Observers	

B 194

MADE at Lagos this 11th day of June, 1964.

R. A. NJOKU,  
*Minister of Transport*

#### EXPLANATORY NOTE

These Rules arrange sea-going ships into classes and regulate the radio and radio direction-finding installations to be provided in each class of ship. The Rules include such requirements as appear to the Minister to implement the provisions of the International Convention for the Safety of Life at Sea, 1948, relating to radiotelegraphy, radiotelephony and direction-finders.

THE MERCHANT SHIPPING (CREW ACCOMMODATION)  
REGULATIONS, 1964

B 195

ARRANGEMENT OF REGULATIONS

1. Short title and application.
2. Interpretation.
3. Structures.
4. Plans.
5. Position of crew accommodation.
6. Height of crew accommodation.
7. Construction of bulkheads and panelling.
8. Overhead decks.
9. Flooring.
10. Protection from weather, etc.
11. Heating.
12. Lighting.
13. Ventilation.
14. Drainage.
15. Painting, etc.
16. Marking.
17. Sleeping rooms.
18. Beds.
19. Furniture and fittings in sleeping rooms.
20. Mess rooms.
21. Furniture and fittings in mess rooms.
22. Recreation spaces and studies.
23. Office accommodation.
24. Washing accommodation.
25. Supply of water to washing accommodation.
26. Supply of drinking water.
27. Laundry facilities, etc.
28. Water closets.
29. Galleys.
30. Dry provision store rooms.
31. Cold store rooms and refrigerating equipment.

32. Hospitals.
33. Medical cabinet.
34. Protection from mosquitoes.
35. Maintenance and inspection of crew accommodation.
36. Inspection by a surveyor of ships.
37. Fees.
38. Accommodation shared with passengers.
39. Additional exemptions.
40. Non-deductible spaces.

FIRST SCHEDULE—Trunked mechanical ventilation.

SECOND SCHEDULE—Deck sheathings.

THIRD SCHEDULE—Insulating material for the underside of decks.

FOURTH SCHEDULE—Marking.

## MERCHANT SHIPPING ACT, 1962

The Merchant Shipping (Crew Accommodation)  
Regulations, 1964*Commencement : 25th June, 1964*

In exercise of the powers conferred by sections 101 and 427 of the Merchant Shipping Act, 1962, the Federal Minister of Transport hereby makes the following Regulations—

1. These Regulations may be cited as the Merchant Shipping (Crew Accommodation) Regulations, 1964, and shall apply to all Nigerian sea-going ships except fishing boats and pleasure yachts. Short title and application.
2. In these regulations, unless the context otherwise requires— Interpretation.
  - “apprentice” includes a Cadet and a Midshipman ;
  - “Chief Officer” includes a first Mate and an only Mate ;
  - “crew” means seamen and apprentices ;
  - “sanitary accommodation” means washing accommodation and accommodation containing water closets or urinals ;
  - “trunked mechanical ventilation system” means a system of ventilation complying with the specifications set forth in the First Schedule to these regulations ;
  - “washing accommodation” does not include—
    - (a) any sleeping room or hospital ward whether or not provided with a wash-basin, bath or shower ; and
    - (b) any room appropriated for use only as a laundry.
  - “whale catcher” includes a ship engaged in towing whales ;
  - “whaling” includes the taking and treatment of seals and walruses, and references to whales shall be construed accordingly.
3. No structure shall be deemed to be watertight, gastight or oiltight for the purposes of these regulations unless all openings in that structure, other than ventilation openings necessary for the admission of air from passageways to sanitary accommodation, laundries, drying rooms or galleys, are provided with means of closure which will enable such openings to be made watertight, gastight or oiltight, as the case may be. Structure.
- 4.—(1) Every person to whose order a ship to which these regulations apply is being constructed shall cause a plan of the ship, on a scale not smaller than 1 in 100, to be submitted to a surveyor of ships on a day not later than the day on which the keel of the ship is laid, showing clearly the proposed arrangement of the crew accommodation in the ship and its proposed position in relation to other spaces therein. Plans.
- (2) Every such person shall cause the following plans to be submitted to a surveyor of ships on a day not later than the day on which the construction of any part of the crew accommodation is begun—
  - (a) plans of the proposed crew accommodation, on a scale not smaller than 1 in 50 in the case of a ship under 500 feet in length and not smaller than 1 in 100 in the case of any other ship, showing clearly the purpose for which each space therein is to be appropriated and the proposed disposition of the furnishings, fittings and obstructions therein ; and

(b) plans showing clearly the proposed arrangements for supplying water to the crew accommodation and for heating, lighting and ventilating the accommodation.

(3) The owner of every ship to which these regulations apply shall submit or cause to be submitted to a surveyor of ships before any alteration or reconstruction is carried out in the crew accommodation thereof plans on the scales and showing the information, referred to in paragraphs (1) and (2) of this regulation, and relating to the crew accommodation as altered or reconstructed, as the case may be: Provided that if the crew accommodation in any ship is altered or reconstructed at a place outside Nigeria in consequence of an emergency or an accident to the ship, such plans shall be submitted to a surveyor of ships as soon as may be.

Position of crew accommodation.

5.—(1) In every ship to which these regulations apply the crew accommodation, other than store rooms, shall be wholly situated above the summer load line, if any, marked on the ship in accordance with section 201 of the Act. The Government Inspector of Shipping may exempt from the requirements of this paragraph—

- (a) any ship of under 200 tons ;
- (b) any passenger ship ;
- (c) any whale catcher ;
- (d) any tug ;
- (e) any cable ship ;
- (f) any salvage ship ;
- (g) any crane ship ;
- (h) any dredger and any ship engaged in the conveyance of the spoil of dredging ; and

(i) any other ship not being a ship engaged in the carriage of cargo, if he is satisfied that compliance therewith is unreasonable or impracticable by reason of the size or intended service of the ship.

(2) In every ship to which these regulations apply the crew accommodation other than store rooms, shall be situated amid-ships or aft. The Government Inspector of Shipping may exempt any ship from the requirements of this paragraph to the extent to which he is satisfied that compliance therewith is unreasonable or impracticable by reason of the size or intended service of the ship ; provided that in ships of 500 tons or over no part of the crew accommodation, other than store rooms, shall be forward of the collision bulkhead.

(3) Sleeping rooms forming part of the crew accommodation of a passenger ship to which these regulations apply shall not be situated immediately beneath a working passageway.

Height of crew accommodation.

6.—(1) In every ship to which these regulations apply the height of the crew accommodation measured from the top of the floor beams to the top of the crown beams shall not be less than the following—

- In ships of under 1,600 tons . . . . . 7 feet ; and
- In ship of 1,600 tons or over . . . . . 7 feet 6 inches

The Government Inspector of Shipping may exempt from the requirements of this paragraph—

- (a) any ship, in respect of store rooms and sanitary accommodation ; and
- (b) any sea-going ship which is for the greater part of her commission employed on inland waters, to the extent to which he is satisfied that compliance therewith is unreasonable or impracticable in the circumstances.

(2) Every sleeping room forming part of the crew accommodation in a ship to which these regulations apply shall be so constructed as to provide a clear headroom of at least 6 feet 3 inches at every point in the room which is available for free movement. The Government Inspector of Shipping may exempt any ship of under 500 tons from the requirements of this paragraph to the extent he is satisfied that compliance therewith is unreasonable or impracticable in the circumstances.

7.—(1) In every ship to which these regulations apply all bulkheads enclosing or within any part of the crew accommodation shall be properly constructed of steel or other suitable material. If the bulkheads are exposed to the weather they shall be of watertight and gastight construction, and means of closure shall be provided for all openings in such bulkheads so as to enable them to be made weathertight.

Construction of bulkheads and panelling.

(2) Any bulkhead which separates any part of the crew accommodation (other than a recreation deck space) from a space used as—

- (a) a permanent coal bunker ;
- (b) an oil fuel bunker ;
- (c) a cargo or machinery space ;
- (d) a lamp room or paint room ;
- (e) a store room not forming part of the crew accommodation (other than a dry provision store room) ;
- (f) a chain locker ; or
- (g) a cofferdam

shall be gastight, and shall be watertight where necessary to protect the crew accommodation.

(3) Any bulkhead which separates any part of the crew accommodation from a dry provision store room (whether or not such store room forms part of the crew accommodation) shall be gastight.

(4) Subject to the provisions of paragraph (5) of regulation 28 of these regulations any bulkhead which separates any part of the crew accommodation from sanitary accommodation or from a laundry or drying room, galley or cold store room (whether or not such sanitary accommodation, laundry, drying room, galley or cold store room forms part of the crew accommodation) shall be gastight, and shall be watertight to such height as is necessary to prevent the passage of water into the adjoining space. In particular any bulkhead separating sanitary accommodation from any other part of the crew accommodation shall, except in a doorway, be watertight to a height of at least 9 inches above the floor of the sanitary accommodation. Provided that the requirements of this paragraph shall not apply to bulkheads separating—

- (a) sanitary accommodation from other sanitary accommodation ;
- (b) a laundry or drying room from another laundry or drying room ;
- (c) a galley from another galley or a pantry ;
- (d) a cold store room from another cold store room ; or
- (e) sanitary accommodation appropriated for the sole use of one person from a sleeping room which it may be directly entered.

(5) Any inside panelling in the crew accommodation shall be constructed of plywood or other suitable material with a surface which can be easily kept clean. Neither bulkheads nor inside panelling shall be constructed with tongued and grooved boarding or in a manner likely to harbour vermin.

8.—(1) In every ship to which these regulations apply, being a ship constructed of steel or other metal, every deck which forms the crown of any part of the crew accommodation (in this regulation referred to as the "overhead deck"), and is exposed to the weather, shall be constructed of steel or other metal. The Government Inspector of Shipping may exempt any ship from the requirements of this paragraph to the extent to which he is satisfied that it is necessary to do so by reason of the intended service of the ship.

(2) The upper side of every such deck shall be sheathed with wood or with a material which complies with the requirements specified in the Second Schedule to these regulations. Such sheathing shall be properly laid and, if it consists of wood, shall be properly caulked. The Government Inspector of Shipping may exempt any ship from the undersides of the overhead decks to the extent to which he is satisfied that the undersides of the overhead decks are insulated with a material (other than wood) which complies with the requirements specified in the Third Schedule to these regulations, and which is so fitted as to avoid as far as possible absorption of water, condensation, transmission of noise and harbouring of dirt and vermin.

(3) Every wooden overhead deck shall be at least  $2\frac{1}{4}$  inches thick and every wooden sheathing shall be at least  $2\frac{1}{4}$  inches thick. The Government Inspector of Shipping may exempt any ship from either of the requirements of this paragraph to the extent that he is satisfied that compliance therewith is unreasonable or impracticable in the circumstances.

Flooring.

9.—(1) In every ship to which these regulations apply the decks which form the floors in the crew accommodation shall be properly constructed and shall have a surface which provides a good foothold and is capable of being easily kept clean. The floor covering shall be impervious to water and, if the deck is situated on top of an oil tank, impervious to oil.

(2) Wooden decks which form the floors in the crew accommodation shall be at least  $2\frac{1}{4}$  inches thick and shall be properly laid and caulked. The Government Inspector of Shipping may exempt any ship from the requirements of this paragraph to the extent to which he is satisfied that the compliance therewith is unreasonable or impracticable in the circumstances.

(3) The surface of metal decks which form the floors of the crew accommodation, not being floors in sanitary accommodation, galleys, store rooms or laundries, shall be covered with linoleum or wooden planking, or with a material which complies with the requirements specified in the Second Schedule to these regulations. The joinings of such material with the side walls shall be rounded in a manner which will avoid crevices. Such linoleum, planking or material shall be properly laid and shall provide a good foothold. The joinings of the floors with the side walls shall be rounded in a manner which will avoid crevices.

Protection  
from  
weather, etc.

10.—(1) In every ship to which these regulations apply the crew accommodation and the means of access thereto and egress therefrom shall be so arranged and constructed and situated in such a position as to ensure—

- (a) the protection of the crew against injury to the greatest practicable extent ;
- (b) the protection of the crew accommodation against the weather and the sea ;
- (c) the insulation of the crew accommodation from heat and cold ;
- (d) the protection of the crew accommodation against moisture due to condensation ;

(e) the exclusion from the crew accommodation of effluvia originating in other spaces in the ship ; and

(f) the exclusion from the crew accommodation, to the greatest practicable extent, of noise originating in other spaces in the ship.

(2) Without prejudice to the generality of the foregoing paragraph—

(a) Every opening from an open deck into the crew accommodation shall be protected against the weather and the sea.

(b) The crew accommodation shall be accessible at all times from the open deck.

(c) Access to sleeping rooms, mess rooms, recreation rooms and studies which form part of the crew accommodation shall be obtained from a passageway which shall be provided with a hinged door at any entrances to the open deck. The Government Inspector of Shipping may exempt any ship from the requirements of this sub-paragraph to the extent to which he is satisfied that compliance therewith is unreasonable or impracticable by reason of the size or intended service of the ship.

(d) Bow hawse pipes shall not be situated in the crew accommodation. The Government Inspector of Shipping may exempt any ship of under 400 tons from the requirements of this sub-paragraph.

(e) Steam supply and exhaust pipes for steering gear, winches and similar equipment shall not pass through the crew accommodation. Provided that, if in the case of any ship of 500 tons or over the Government Inspector of Shipping is satisfied that alternative arrangements are unreasonable or impracticable in the circumstances, he may permit such pipes, if properly encased, to pass through passageways forming part of the crew accommodation subject, in the case of supply pipes, to the following conditions—

(i) the pipes shall be constructed of solid drawn steel or other suitable material ;

(ii) the pipes shall be of a scantling sufficient to withstand the maximum pressure from the ship's boiler system ;

(iii) all connections in the pipes shall be by faced flanges properly jointed ; and

(iv) the pipes shall be fitted with adequate drainage arrangement. The Government Inspector of Shipping may exempt any ship of under 500 tons from the requirements of this sub-paragraph if he is satisfied that adequate arrangements have been made to ensure the safety of the crew.

(f) All steam pipes, hot water pipes and calorifiers in or serving the crew accommodation shall be efficiently lagged wherever lagging is necessary for the conservation of heat or the protection of the crew against injury or discomfort. All cold water pipes in the crew accommodation shall be efficiently lagged wherever lagging is necessary for the prevention of condensation.

(g) Chain pipes, and ventilator trunks to cargo spaces or tanks, shall be made of steel or other suitable material and shall be gastight where they pass through any part of the crew accommodation.

(h) Batteries for the operation of the ship's radio installation, if any, shall not be placed in any sleeping room provided for the crew, and precautions shall be taken which will ensure that fumes from such batteries cannot discharge into any part of the crew accommodation.

(i) The bulkheads and the parts of the ship's side which enclose the crew accommodation, shall be insulated in a manner which will prevent overheating of the accommodation, and shall be covered with protective covering which will prevent the condensation of moisture. The Government Inspector of Shipping may exempt any ship from the requirements of this sub-paragraph to the extent to which he is satisfied that the crew accommodation is adequately protected by its position and ventilation against overheating and condensation.

(j) Every bulkhead, casing and deck separating the crew accommodation from other spaces in the ship in which heat or cold may be generated shall be insulated in a manner which will prevent the crew accommodation being so affected by such heat or cold or by condensation as to prejudice the health or comfort of the crew.

(k) Every ship for the time being regularly engaged on voyages to, within or through the Tropics or the Persian Gulf shall be provided with awnings which will cover—

(i) all exposed decks and house-tops situated immediately above any part of the crew accommodation ;

(ii) all exposed sides of galleys situated on an open deck ;

(iii) such portions of the deck spaces provided for the recreation of the crew in compliance with paragraph (6) of Regulation 22 of these regulations as will provide a shaded area adequate in extent having regard to the number of persons in the crew and to any shade provided for such spaces by overhanging decks.

The awnings shall be supported by stanchions or by other suitable means.

(l) There shall be no direct opening between the crew accommodation (other than recreation deck spaces) and any space used as a store room for engine room stores or deck department stores. The Government Inspector of Shipping may exempt—

(i) any ship of under 500 tons ; and

(ii) any whale catcher from the requirements of this sub-paragraph to the extent to which he is satisfied that compliance therewith is impracticable in the circumstances.

(m) There shall be no direct opening between the crew accommodation (other than recreation deck spaces) and spaces used as—

(i) permanent coal bunkers ;

(ii) oil fuel bunkers ;

(iii) cargo or machinery spaces ;

(iv) lamp rooms or paint rooms ;

(v) store rooms not forming part of the crew accommodation (other than store rooms for engine room or deck department stores) ;

(vi) chain lockers ; or

(vii) cofferdams.

Provided that there may be a direct opening between machinery spaces and sanitary accommodation and changing rooms provided for the sole use of officers and ratings of the engine room department. The Government Inspector of Shipping may exempt any ship from the requirements of this sub-paragraph in so far as it relates to a direct opening between any passageway forming part of the crew accommodation and any of the aforesaid spaces. The Government Inspector of Shipping may further

exempt any whale catcher from such requirement in so far as it relates to a direct opening between any machinery space and any part of the crew accommodation.

(n) Subject to the provisions of paragraph (3) of regulation 24, paragraph (6) of regulation 28 and paragraph (16) of regulation 32 of these regulations there shall be no direct opening between the crew accommodation (other than recreation deck spaces or passageways) and any sanitary accommodation, laundry or drying room (whether or not such sanitary accommodation, laundry or drying room forms part of the crew accommodation). Provided that nothing in this sub-paragraph shall prohibit direct openings between spaces forming part of the sanitary accommodation, or between spaces appropriated for use as laundries or drying rooms.

(o) Any part of the crew accommodation which is adjacent to any part (other than the crown) of a tank in which oil may be carried in bulk, shall be separated therefrom by a gastight division additional to the division which retains the oil. The Government Inspector of Shipping may exempt any ship from the requirement of this sub-paragraph if he is satisfied that the division which retains the oil is likely to remain oiltight under service conditions.

(p) If any part of the crew accommodation is situated on a deck which forms the crown of a space in which oil may be carried in bulk, such deck shall be oiltight. No manholes or other openings to the oil tanks shall be situated in the crew accommodation. The Government Inspector of Shipping may exempt any ship used in treating whales or for the carriage of persons employed in catching or treating whales from the requirements of this sub-paragraph in so far as they relate to manholes or other openings in the oil tanks.

(q) If any part of the crew accommodation is situated on a deck forming the crown of a permanent coal bunker, such deck shall be gastight.

(r) The means of access to and egress from every part of the crew accommodation shall be so situated that in the event of fire in any lamp room or paint room in the ship, access to and egress from the crew accommodation will not be impeded.

11.—(1) In every ship to which these regulations apply, other than a ship employed solely within the Tropics or the Persian Gulf, all sleeping rooms, mess rooms, recreation rooms, sanitary accommodation, offices, studies and hospitals forming part of the crew accommodation shall be provided with a heating system which shall be permanently installed and capable of ensuring that when the ventilation system provided for such rooms or accommodation in compliance with these regulations is working so as to furnish at least 15 cubic feet of fresh air per minute for each person whom the room or accommodation is designed to accommodate at one time and the temperature of the open air is 30° F. the temperature therein can be maintained at 67° F. Provided that the temperature within a water closet shall not be required to be maintained at more than 10° F. above the ambient temperature in the open air. If the temperature within any water closet is capable of being so maintained by heat derived from an adjoining compartment, a heating system shall not be required to be provided in that water closet. The Government Inspector of Shipping may exempt from the requirements of this paragraph—

- (i) any ship of under 500 tons, and  
 (ii) any ship intended to be engaged solely on voyages in the Tropics or the Persian Gulf if he is satisfied that the crew accommodation is fitted with stoves which are properly installed and adequately guarded, or with other suitable means of heating.

Heating.

(2) The permanent heating system required by the foregoing paragraph shall be operated by steam, hot water or electricity, or shall be a system supplying warm air.

(3) The heating equipment shall be so constructed, installed and, if necessary, shielded as to avoid the risk of fire and not to constitute a source of danger or discomfort to the crew. In particular, means shall be provided, unless the provision thereof is unreasonable or impracticable in the circumstances, by which, without the use of a tool or key, the heat emitted by the radiator or other heating device fitted in any space can be turned off and on and varied. The heating equipment shall be so constructed that its operation is not affected by the use or non-use of any steering gear, deck machinery, calorifiers or cooking appliances in the ship.

(4) The heating system shall be in operation at all times when any members of the crew are living or working on board the ship and circumstances require its use. Provided that while the ship is in port the heating system shall not be required to be in operation if efficient temporary means of heating are provided for such parts of the crew accommodation as are in use.

#### Lighting.

12.—(1) In every ship to which these regulations apply every part of the crew accommodation, other than pantries, laundries, drying rooms, lockers and store rooms shall be properly lighted by natural light. Provided that if in any space in a passenger ship or in a ship engaged in the whaling industry it is impracticable to provide proper natural lighting, such lighting shall not be required if adequate electric lighting is always available in that space. The Government Inspector of Shipping may exempt any ship from the requirement of this paragraph in relation to sanitary accommodation and passageways to the extent to which he is satisfied that compliance therewith is unreasonable or impracticable in the circumstances.

(2) The natural lighting of a sleeping room, mess room, recreation room or hospital ward shall be deemed to be proper for the purposes of this regulation if it is sufficient to enable an ordinary newspaper to be read by a person of normal vision at any point in the room, being a point available for free movement, during day time and in clear weather.

(3) Every side scuttle in a sleeping room, mess room, smoking room or recreation room in the crew accommodation shall be capable of being opened. Provided that this paragraph shall not apply to a side scuttle which is required to be of the non-opening type by the provisions of the Merchant Shipping (Passenger Ship Construction) Rules.

(4) In every ship of 3,000 tons or over every such side scuttle shall be at least 12 inches in diameter. The Government Inspector of Shipping may exempt any ship from the requirement of this paragraph to the extent to which he is satisfied that compliance therewith is unreasonable or impracticable in the circumstances.

(5) In every ship to which these regulations apply an electrical system shall be installed which is capable of providing adequate lighting in every part of the crew accommodation. The electric lights shall be so arranged as to give the maximum benefit to the crew, and in particular an electric reading light shall be fitted at the head of each bed and shall be capable of being switched on and off from the bed. A lamp emitting at least 200 lumens shall be fitted in every such reading light in a sleeping room, and a lamp emitting at least 400 lumens shall be fitted in every such light in a hospital ward. An efficient alternative

system of lighting or source of electric power shall always be available for lighting the crew accommodation. The Government Inspector of Shipping may exempt any ship of under 500 tons from the requirement of this paragraph if he is satisfied that compliance therewith is unreasonable or impracticable in the circumstances and that other suitable artificial lighting is provided in the crew accommodation.

(6)—(a) In addition to any other lights required by these regulations the spaces referred to in sub-paragraphs (d) to (n) inclusive of this paragraph shall be provided with the lighting therein specified.

(b) The electric lighting of the spaces referred to in sub-paragraphs (d) to (n) inclusive of this paragraph shall be deemed to be adequate for the purposes of these Regulations if, when the lamps and paintwork are new, the illumination in the horizontal plane, when measured at the points and in the manner prescribed in sub-paragraph (c) of this paragraph is steady and subject to a tolerance of 10 per cent. is maintained at a value of not less than that prescribed for every such space.

(c) The points at which illumination shall be measured shall be as follows—

(i) Where general measurement points are prescribed for the illumination of a space, then measurements shall be taken at every point midway between every two adjacent lamps and at every point midway between every lamp and any position on any boundary of the space.

Provided always that where within any space a part of that space (being a part of that space available for free movement) is shaded from the direct rays of a lamp by a re-entrant angle formed in the boundary of the space, then the central point of the part of the space so shaded shall also be a general measurement point ; and

(ii) Where particular measurement points are also prescribed for a space, then measurements shall in addition be taken at every such point.

In all cases measurements shall be taken at a height of 2 feet 9 inches above the floor, except that in the case of passageways, companionways, and covered recreation deck spaces, measurements may be taken either at a height of 2 feet 9 inches above the floor or at floor level, provided that in the latter case the reflection factor of the floor surface shall not be less than 40 per cent. Illumination of provision store rooms shall be measured when the rooms are empty.

(d) *Sleeping Rooms and Day Rooms*—

2 foot-candles immediately in front of any drawer, bookcase, clothes locker, wardrobe and toilet mirror.

5 foot-candles at any wash-basin.

6 foot-candles at any seat at a writing desk or table, and at not less than half the remaining seats in a sleeping room provided for the use of more than one person.

For the purposes of this sub-paragraph reading lights at the heads of beds shall not be taken into account in determining the illumination of a space except in the case of a sleeping room provided for the use of one person only.

(e) *Mess Rooms*—

2 foot-candles at general measuring points.

5 foot-candles at any table and sink.

(f) *Recreation and Smoking Rooms*—

2 foot-candles at general measuring points.

5 foot-candles at the recreation tables.

6 foot-candles at any seat at a writing position at a desk or table and at not less than half the remaining seats.

(g) *Hospital Wards*—

2 foot-candles at general measuring points.

5 foot-candles at any wash-basin.

In addition to the electric reading lamp required to be provided at the head of each bed in accordance with paragraph (5) of this regulation, the portable electric lamp least one fixed lamp shall be installed. The portable electric lamp required to be provided by paragraph (10) of regulation 32 of these regulations shall emit at least 600 lumens.

For the purposes of this sub-paragraph reading lights at the head of beds shall not be taken into account in determining illumination except in the case of a hospital ward provided for the use of one person only.

(h) *Offices and Studies*—

2 foot-candles immediately in front of any drawer and any bookcase.

8 foot-candles at every writing position at a desk or table.

(i) *Sanitary Accommodation* (including such accommodation in Hospitals)—

Water Closets—3 foot-candles in way of the pan.

Wash Rooms and Bathrooms—3 foot-candles at all general measurement points.

5 foot-candles at any wash-basin or washing trough and at or near the head of any bath.

(j) *Laundries*—

3 foot-candles at general measuring points.

5 foot-candles at any washing trough.

(k) *Drying Rooms*—

2 foot-candles in the centre of the space.

(l) *Galleys (including Bakeries and Pantries)*—

6 foot-candles at working positions.

The lamps shall be so disposed as to ensure that the food preparation tables, the range top, the serving tables and the washing up sinks receive the maximum amount of light.

(m) *Provision Store Rooms*—*Dry Store Rooms*

2 foot-candles at general measurement points.

2 foot-candles immediately in front of shelving and any cupboard.

*Cold Store Rooms*

Half the standard prescribed for a Dry Store Room.

(n) *Passageways, Companionways and Covered Recreation Deck Spaces.*

2 foot-candles at general measurement points.

A lamp shall be placed at or near the head of each stairway or ladder or hatchway and at or near doors of any lockers provided for oilskins or working clothes.

## Ventilations.

13.—(1) In every ship to which these regulations apply the enclosed parts of the crew accommodation shall be ventilated by a system which will maintain the air therein in a state of purity adequate for the health and comfort of the crew. Such system shall be capable of being so controlled as to ensure a sufficiency of air movement under all conditions of weather and climate to which the ship is likely to be subjected during the voyages on which she is intended to be engaged, and shall be additional to any side scuttles, skylights, companions, doors or other apertures not intended solely for ventilation.

(2) (a) Every such enclosed space, being a space not ventilated by a trunked mechanical ventilation system, shall be provided with a natural system of inlet and exhaust ventilation. Every inlet ventilator forming part of such system, being a ventilator situated in the open air, shall be of a cowl or other equally efficient type and shall be so situated that, as far as is practicable, it is not screened from the wind in any direction. No such ventilator shall be situated directly over a doorway, stairway or exhaust opening.

(b) The sectional area of every part of the inlet and exhaust system (other than a part serving only a drying room or locker) shall be at least six square inches for each person for whose use at any one time the space is appropriated, and shall be not less than 19 square inches in all at any point in the system. The effective area of the inlet and exhaust system serving each space shall be capable of being adjusted from fully open down to a minimum of 3 square inches for each person likely to use the space at any one time.

(3) Every such enclosed space, other than a cold store room, forming part of the crew accommodation of a ship to which these regulations apply, of 500 tons or over, shall be provided with a trunked mechanical ventilation system complying with the requirements specified in the First Schedule to these regulations. Provided that such a system shall not be required in any galley, which is situated on an open deck and exposed to the weather on the fore end and the port and starboard sides. The Government Inspector of Shipping may exempt any ship from the requirement of this paragraph, in so far as it relates to the ventilation of a store room for the storage of dry provisions, if he is satisfied that compliance with that requirement is unnecessary by reason of the position of the store room.

(4) In the crew accommodation of every ship to which these regulations apply, being a ship not provided with trunked mechanical ventilation and not being a ship for the time being regularly engaged only on voyages north of 53° North latitude or south of 45° South latitude, an electric fan shall be fitted in every sleeping room, mess room, recreation room, study, office, galley and pantry. The Government Inspector of Shipping may exempt any ship of under 500 tons from the requirement of this paragraph.

(5) Power for the operation of the trunked mechanical ventilation system or fans, as the case may be, required by the foregoing paragraphs of this regulation shall be available at all times when any members of the crew are on board the ship and circumstances require such system or fans to be used.

(6) The following spare gear shall be provided for each size of electric motor employed to operate a trunked mechanical ventilation system in the crew accommodation of a ship to which these regulations apply—

For direct Current Motors—

- 1 Armature
- 1 Field coil
- 1 Set of bearings
- 1 Set of carbon brushes
- 1 Brush holder

For Alternating Current Motors—

- 1 Set of stator windings, complete with insulation pieces.
- 1 Set of bearings.

The spare gear shall be properly packed for storage.

Drainage.

14.—(1) In every ship to which these regulations apply efficient drainage by pipes or channels shall be provided for every part of the crew accommodation situated on an open deck wherever such drainage is necessary for clearing water shipped from the sea.

(2) There shall be no drainage from any source (not being sanitary accommodation) into the sanitary accommodation forming part of the crew accommodation.

(3) Every space appropriated for use as sanitary accommodation shall be served by one or more scuppers which do not serve any space other than sanitary accommodation. The scuppers shall be at least 2 inches in diameter and shall be situated wherever water is likely to collect on the floor of the space. Provided that no scupper shall be required in washing accommodation appropriated for the sole use of one person.

Painting,  
etc.

15.—(1) In every ship to which these regulations apply the interior sides and ceilings of every part of the crew accommodation shall be covered with enamel, paint or other suitable material. The paint, enamel or other material shall be of good quality and white or light in colour.

(2) Lime wash or paint containing nitro-cellulose shall not be applied in the crew accommodation.

(3) The wooden parts of the furniture and fittings in the crew accommodation shall be finished externally with paint, varnish, polish or by other suitable means.

(4) All paint, varnish, polish and other finishes in the crew accommodation shall be capable of being easily kept clean and shall be maintained in good condition.

Marking.

16.—(1) Every sleeping room forming part of the crew accommodation of a ship to which these regulations apply shall be marked inside the room with whichever of the markings specified in Part I of the Fourth Schedule to these regulations is appropriate in the circumstances.

(2) Every space, other than a sleeping room or an open deck, forming part of the crew accommodation of such a ship shall be marked either inside the space or on or over the door to such space with whichever of the markings specified in Part II of the Fourth Schedule to these regulations is appropriate in the circumstances.

(3) All markings required by the foregoing provisions of this regulation shall be in clear characters and in a readily visible position on the ship's structure. The markings shall be cut into the structure or otherwise marked in an equally permanent manner.

(4) No space forming part of the crew accommodation of a ship to which these regulations apply shall be marked, whether inside or outside the space, with any marking which may be taken to indicate that the space is appropriated for use by persons differing in number or description from the persons for whose use the space has been certified by a surveyor of ships.

Sleeping  
Rooms.

17.—(1) In every ship to which these regulations apply, unless the circumstances are such that no members of the crew are required to sleep on board, sleeping rooms shall be provided for the crew in accordance with the following provisions of this regulation. Separate and appropriate sleeping rooms shall be provided wherever required by the widely different national habits and customs of groups of persons in the crew.

(2) (a) Each of the following classes of persons shall be provided with sleeping rooms separated from those provided for the other classes :—

- (i) Officers.
  - (ii) Petty Officers.
  - (iii) Apprentices.
  - (iv) Ratings of the deck department, other than petty officers.
  - (v) Ratings of the engine room department, other than petty officers.
  - (vi) Ratings of the catering department, other than petty officers.
- (b) Every watch of ratings shall be provided with sleeping rooms separate from those of other watches. Day-men shall be provided with sleeping rooms separate from those of watch-keepers.

The Government Inspector of Shipping may exempt from the requirements of this paragraph—

- (i) any whale catcher ; and
- (ii) any other ship to the extent that he is satisfied that compliance with the said requirement is unreasonable or impracticable by reason of the size of the ship.

The Government Inspector of Shipping may further exempt any ship engaged in the whaling industry from the requirements of sub-paragraph (b) of this paragraph.

(3) The maximum number of persons accommodated in sleeping rooms shall be as follows—

- (a) Officers in charge of a department, navigating and engineer officers in charge of a watch, and First or only Radio Officers :—1 person per room.
- (b) Other officers :—wherever practicable 1 person per room and in no event more than 2 persons per room.
- (c) Apprentices :—wherever practicable not more than 3 persons per room, and in no event more than 4 persons per room.
- (d) Chief or only steward and chief or only cook, in either case in a ship of 3,000 tons or over regularly employed otherwise than as a home trade ship :—1 person per room.
- (e) Petty officers not being persons referred to in sub-paragraph (d) :—wherever practicable 1 person per room, and in no event more than 2 persons per room.
- (f) Other ratings :—wherever practicable 2 or 3 persons per room, and in no event more than 4 persons per room ; provided that in any passenger ship the Government Inspector of Shipping may permit more than 4, but not more than 10, such ratings to be accommodated in one room if he is satisfied, after consultation with the owner of the ship or with such organisation or organisations as appear to him to be representative of the ratings concerned, that the comfort of these ratings will thereby be increased.

The Government Inspector of Shipping may exempt any ship used in treating whales or for the carriage of persons employed in catching or treating whales, from the requirements of this paragraph in so far as they relate to sleeping accommodation for persons not engaged to work the ship. The Government Inspector of Shipping may exempt also any whale catcher from the requirements of sub-paragraph (a) of this paragraph and any ship of under 400 tons from the requirements of sub-paragraphs (a) and (d) of this paragraph.

(4) Subject to the provisions of sub-paragraphs (b) and (c) of this paragraph, the minimum floor area provided for each person in a sleeping room forming part of the crew accommodation of a ship to which these regulations apply shall be as follows—

	<i>Square Feet</i>
(a)	15
In ships of under 400 tons	20
In ships of 400 tons or over but under 800 tons	25
In ships of 800 tons or over but under 3,000 tons	30
In ships of 3,000 tons or over	

(b) Subject to the provisions of sub-paragraph (c) of this paragraph the minimum floor area provided in a sleeping room in a passenger ship shall be 24 square feet per person if more than 4 ratings are accommodated in that room.

(c) Subject to the provisions of this sub-paragraph the minimum floor area provided for each person in a sleeping room for such ratings as are referred to in paragraph (2) of regulation 39 of these regulations (in this sub-paragraph referred to as "special ratings") shall be as follows—

	<i>Square Feet</i>
	14
In ships of under 400 tons	18
In ships of 400 tons or over but under 3,000 tons	20
In ships of 3,000 tons or over	

The total floor area of the sleeping rooms provided in the ship for special ratings shall not be less than would be required by sub-paragraph (a) of this paragraph to be provided for such number of ratings as would be necessary in substitution for the special ratings if the special ratings were replaced by other ratings.

(d) In determining the floor area of a room for the purpose of this paragraph spaces occupied by berths, lockers, seats or chests of drawers shall be taken into account and spaces which by reason of their small size or irregular shape cannot accommodate furniture and do not contribute to the area available for free movement shall not be taken into account.

18. (1) Every sleeping room in the crew accommodation of a ship to which these regulations apply shall be fitted with a bed for each person accommodated in the room.

Bed.

(2) The framework of each bed, and the lee-boards or lee-rails thereof, if any, shall be constructed of metal or other material which is hard smooth and unlikely to become corroded. The framework shall be so made as not to be likely to harbour vermin. In particular, if the bed is constructed with tubular frames, the frames shall be completely sealed and without perforations.

(3) There shall be unobstructed access to at least one side of each bed and, in particular, if the adjacent sides of two beds in the same room are parallel to each other or, when projected, make an angle of less than 90° with each other, the distance between those sides at any point shall not be less than 2 feet 6 inches if both beds are in single tier or 3 feet in any other case.

(4) Where beds abutt upon each other they shall be separated by screens made of wood or other suitable material.

(5) No bed shall be placed—

(a) within 4 inches of a ventilation trunk which may be used for circulating hot air, or

(b) within 2 inches of a bulkhead or the ship's side, unless the bed is so supported and the room so constructed as to avoid harbouring dirt and vermin in or near the bed, to enable the bedding to be kept clean and dry, and to minimise the soiling of paint work in way of the bed.

(6) Beds shall not be arranged in tiers of more than two.

(7) Beds placed along the ship's side shall be in single tier, except in a room in which there is no side scuttle. The Government Inspector of Shipping may exempt any ship from the requirement of this paragraph to the extent to which he is satisfied that the beds in the sleeping room are clear of side scuttles, and that the comfort of the crew will thereby be increased.

(8) No bed shall—

(a) be less than 1 foot from the floor of the room measured from the bottom of the mattress referred to in paragraph (10) of this regulation ; and

(b) if the upper bed in a double tier, be at least 2 feet 6 inches below the lower side of the deck head beams or other obstructions measured from the bottom of the mattress. The bottom of the mattress in the lower bed shall be at least 3 feet below the bottom of the mattress in the upper bed if the height of the sleeping room is 7 feet 6 inches or more, and at least 2 feet 9 inches below the bottom of the mattress in the upper bed if the height of the sleeping room is less than 7 feet 6 inches. For the purposes of this sub-paragraph the height of the room shall be measured from the top of the floor beams to the top of the crown beams.

The Government Inspector of Shipping may exempt—

(i) any ship of under 500 tons from any of the requirements of this paragraph ; and

(ii) any ship from the requirements of sub-paragraph (b) of this paragraph to the extent to which he is satisfied that it is unreasonable or impracticable in the circumstances to remove obstructions above the beds in the crew accommodation of that ship.

(9) The size of the beds provided for the crew shall—

(a) subject to the provisions of sub-paragraph (b) of this paragraph, be at least 6 feet 3 inches by 2 feet 3 inches, the measurements being taken inside the lee-boards or lee-rails, if any, and at right angles to each other ;

(b) in a ship of 3,000 tons or over for the Chief Officer and for the Chief and Second Engineers, be at least 6 feet 3 inches by 2 feet 9 inches in a passenger ship and at least 6 feet 3 inches by 3 feet 6 inches in any other ship, the measurements in each case being taken as aforesaid.

(10) Every bed provided for a member of the crew shall be fitted with a spring bottom or spring under-mattress, and with a mattress made of material which will resist damp and is unlikely to harbour vermin. A bottom of wood, canvas or other dust-proof material shall be fitted to every bed which is fitted above another bed.

19.—(1) In every ship to which these regulations apply every sleeping room for ratings other than petty officers shall be provided with the following equipment—

(a) For each person accommodated in the room—

(i) one drawer having a capacity of at least 2 cubic feet ; and

Furniture and fittings in sleeping rooms.

(ii) one clothes locker or wardrobe, in either case at least 5 feet 6 inches in height and 315 square inches in internal sectional area; the locker or wardrobe shall be fitted with a shelf not less than 9 inches and not more than 15 inches below its top and with fittings on which clothes may be hung;

(iii) at least one coat hook in addition to any coat hooks fitted in a locker or wardrobe;

(b) A table of fixed or drop-leaf type, or a desk, or a sliding leaf or top fitted to a chest of drawers;

(c) Comfortable seats sufficient to accommodate a tone time all the persons accommodated in the room. Such seats shall be provided in addition to the beds in the room. The Government Inspector of Shipping may exempt any passenger ship or ship engaged in the whaling industry from the requirements of this sub-paragraph to the extent to which he is satisfied that a lesser number of seats is adequate in the circumstances;

(d) A mirror suitable for toilet purposes;

(e) A cabinet suitable for containing toilet requisites;

(f) A book rack;

(g) A runner of jute, coir or other suitable material at one side of each bed or tier of beds, as the case may be;

(h) A curtain fitted to each bed, unless the room accommodates only one person; and

(i) A curtain fitted to each side scuttle, unless the side scuttle is fitted with blinds or jalousies.

The Government Inspector of Shipping may exempt any whale catcher from any of the requirements of sub-paragraphs (g), (h) and (i) of this paragraph.

(2) Paragraph (1) of this regulation shall apply to sleeping rooms for petty officers as it applies to sleeping rooms for other ratings, subject to the following modifications and additions:—

(a) For each person accommodated in the room a second drawer having a capacity of at least 2 cubic feet shall be provided in addition to the drawer referred to in sub-paragraph (a) of paragraph (1) of this regulation.

(b) The clothes lockers or wardrobes provided shall be made of hard-wood.

(c) Each room shall be provided with—

(i) a rack for holding one drinking-water bottle and one tumbler for each person accommodated in the room. The rack may be fitted inside the cabinet for toilet requisites. Provided that a rack for holding a drinking-water bottle shall not be required in any room in which a supply of drinking-water is laid on;

(ii) a wash basin, of vitreous china or other equally hygienic and durable material, which shall be fitted with an efficient and hygienic discharge overside or to an enclosed tank with a suction pipe served by a mechanically operated pump; provided that a wash-basin shall not be required to be fitted in a sleeping room for petty officers if washing accommodation is readily accessible from the sleeping room.

(3) In every sleeping room in which more than one petty officer or other rating is accommodated, every drawer, locker and wardrobe shall be fitted with a secure lock or hasp for a padlock. In every sleeping room in which only one petty officer or other rating is accommodated the locker or wardrobe shall be fitted with such a lock or hasp.

(4) Subject to the provisions of paragraph 5 of this regulation every sleeping room for officers shall be provided with the following equipment:—

(a) For each officer accommodated in the room—

(i) at least three drawers with a total capacity of 10 cubic feet or as near thereto as is practicable in the circumstances;

(ii) a wardrobe at least 5 feet 6 inches in height and 460 square inches in internal sectional area;

(iii) at least two coat hooks, in addition to any coat hooks fitted in the wardrobe;

(b) A writing desk fitted, if practicable, with drawers additional to the aforesaid drawers;

(c) A chair with arm rests;

(d) A settee at least 6 feet in length or as near thereto as is practicable in the circumstances; provided that the Government Inspector of Shipping may permit the settee to be dispensed with—

(i) if he is satisfied that a settee of adequate dimensions cannot be placed in the room without interfering with the comfort of the officers; or

(ii) in the case of a room which only accommodates one officer, if the Government Inspector of Shipping has consulted with such organisation as appears to him to be representative of the class of officer concerned and is satisfied that a fully upholstered easy chair with closed arms is provided in the room.

(e) A mirror suitable for toilet purpose;

(f) A cabinet suitable for containing toilet requisites;

(g) A rack suitable for holding—

(i) one drinking-water bottle, and

(ii) one tumbler for each officer accommodated in the room. The rack may be fitted inside the cabinet for toilet requisites. Provided that a rack for holding a drinking-water bottle shall not be required in any room in which a supply of drinking-water is laid on.

(h) A wash-basin of vitreous china or other equally hygienic and durable material, which shall be fitted with an efficient and hygienic discharge overside or to an enclosed tank with a suction pipe served by a mechanically operated pump. Provided that a wash-basin shall not be required to be fitted in a sleeping room if washing accommodation is readily accessible therefrom.

(i) A splash plate or other means of protection for the wall above the wash-basin, if any;

(j) A carpet runner of wool or similar material;

(k) Curtains fitted to each bed, unless the room accommodates only one officer;

(l) Curtains fitted to each side scuttle, unless the side scuttle is fitted with blinds or jalousies;

(m) A book case in any room which accommodates a Chief Officer, Chief Engineer or Second Engineer, or in the case of a passenger ship a First Radio Officer; and

(n) A book case or book rack in rooms which accommodate other Officers.

The Government Inspector of Shipping may exempt any ship of under 400 tons from any of the requirements of sub-paragraphs (a), (b) and sub-paragraphs (k) to (n) inclusive, of this paragraph to the extent to which he is satisfied that compliance therewith is unreasonable or impracticable in the circumstances.

(5) Any of the equipment referred to in sub-paragraphs (b), (c), (d), (m) and (n) of paragraph (4) of this regulation may be provided in a day room available for the sole use of the officers concerned, instead of their sleeping room. Any of the equipment referred to in sub-paragraphs (e) to (i) inclusive of the said paragraph may be provided in washing accommodation approved for the exclusive use of one officer instead of in the sleeping room of that officer.

(6) Sleeping rooms for apprentices shall so far as is reasonable and practicable in the circumstances be provided with the equipment (other than a book case) referred to in paragraph (4) of this regulation. Provided that any of the equipment referred to in sub-paragraphs (b), (c), and (d) of the said paragraph may be provided in a study for the sole use of the apprentices instead of in their sleeping rooms.

(7) Subject to the foregoing provisions of this regulation, all lockers, wardrobes, tables, desks, the un-upholstered parts of chairs and settees and similar furnishings provided in compliance with this regulation shall be made of polished hardwood, rustproof metal or other smooth and impervious material not likely to crack, warp or become corroded. All furniture provided in sleeping rooms shall be so made as not to be likely to harbour vermin.

Mess  
Rooms.

20.—(1) In every ship to which these regulations apply, unless the circumstances are such that no members of the crew are required to mess on board, mess rooms shall be provided for the crew and shall be of such dimensions as will be sufficient to accommodate the greatest number of persons likely to use them at any one time. Separate and appropriate mess rooms shall be provided wherever required by the widely different national habits and customs of groups of persons in the crew.

(2) No mess room shall be combined with a sleeping room. The Government Inspector of Shipping may exempt any ship of under 300 tons from the provision of this paragraph if he is satisfied that compliance therewith is unreasonable or impracticable in the circumstances.

(3) In every ship of 500 tons or over the mess rooms provided for ratings shall be separate from those provided for the Master of the ship or for officers.

(4) In every ship of 1,000 tons or over a single mess room shall be provided for all officers in the ship. Provided that the officers may be accommodated in separate mess rooms if their sleeping rooms are in widely separated portions of the ship.

(5) In every ship of 1,000 tons or over each of the following classes of ratings shall be provided with mess rooms separate from those provided for the other classes :—

- (a) petty officers of the deck department ;
- (b) petty officers of the engine room department ;
- (c) other ratings of the deck department ;
- (d) other ratings of the engine room department.

Subject to the provisions of paragraph (1) of this regulation the Government Inspector of Shipping may permit the provision in any ship of combined mess rooms as follows—

- (i) for petty officers of the deck and engine room departments ;
- (ii) for petty officers and other ratings of the same department ;
- (iii) for all ratings (other than petty officers) of the deck and engine room departments.

Subject as aforesaid the Government Inspector of Shipping may further permit the provision in any ship of a single mess room for all petty officers and other ratings of all departments, if he is satisfied that such an arrangement is preferred either by the owner of the ship or by an organisation which appears to the Government Inspector of Shipping to be representative of owners of Nigerian ships, and by an organisation which appears to him to be representative of the seamen concerned.

(6) In every ship of 3,000 tons or over, being either—

- (a) a ship other than a home trade ship, or
  - (b) a home trade ship with a catering department of more than 5 persons,
- mess rooms shall be provided for ratings of the catering department which shall be separate from those provided for ratings of other departments, unless the Government Inspector permits a combined mess room for petty officers and other ratings of all departments in accordance with the provisions of paragraph (5) of this regulation.

If in any other ship, a separate mess room is not provided for ratings of the catering department, messing accommodation shall be provided for them in mess rooms provided for other ratings.

(7) Apprentices shall be provided with a separate mess room or with messing accommodation in the officers' mess room.

(8) The Government Inspector of Shipping may exempt—

- (a) any passenger ship ; and
- (b) any ship engaged in the whaling industry

from the requirements of this regulation to the extent to which is satisfied that compliance therewith is unreasonable or impracticable in the circumstances.

21.—(1) Every mess room forming part of the crew accommodation in a ship to which these regulations apply shall be provided with sufficient tables to allow a space of at least 20 inches measured along the edge of a table for each person likely to use the room at any one time. Each table shall be at least 24 inches wide if seats are provided on both sides of the table, and at least 15 inches wide if seats are provided only on one side of the table. The table shall be of such a size and so situated as to be readily accessible.

Furniture  
and fittings  
in Mess  
Rooms.

(2) Single chairs shall be provided in the mess room for each person using the room at any one time. Such chairs shall be fitted with arm rests unless chairs with arm rests are available in a recreation room for the persons using the mess room. Provided that settees may be substituted for chairs adjacent to a bulkhead or the ship's side. Such settees shall be at least 15 inches wide and shall be fitted with upholstered or padded seats covered with material impervious to dirt and moisture, and shall be provided with comfortably shaped backs. If the mess room is appropriated for use by officers or petty officers, whether or not together with other ratings, the backs of the settees shall also be padded or upholstered and shall be covered with material impervious to dirt and moisture.

(3) Every mess room provided for persons who do not provide their own food shall be fitted with either—

(a) a storage locker or rack in either case capable of holding sufficient mess utensils for those persons, or

(b) a storage locker at least 15 inches by 15 inches by 12 inches in size for each of those persons.

Every mess room provided for persons who provide their own food shall be fitted with a storage locker for each person which shall be of sufficient size to be capable of containing his mess utensils together with a supply of food sufficient for him for at least 7 days. All storage lockers provided in compliance with this paragraph shall be adequately ventilated, and all storage lockers provided for one person shall be fitted with a lock or hasp for a padlock, and shall be so fixed as to clear the floor by at least 1 foot.

Provided that the lockers or racks may be fitted in a pantry, store room or other suitable place outside a mess room, and readily accessible therefrom. No lockers or racks, being lockers or racks intended to contain food, shall be fitted in a sleeping room, not being a sleeping room combined with a mess room.

(4) A dresser, hot-press, sink and boiler or other means from which boiling drinking water shall always be available shall be fitted in each mess room, unless such equipment is fitted in a pantry readily accessible from the mess room or, in the case of a ship of under 1,000 tons, in a galley. Such equipment shall be adequate in size for the number of persons likely to use the room at any one time. If in the case of a mess room provided for officers or petty officers the dresser is fitted in a pantry a sideboard shall be provided in the mess room. A supply of fresh water shall be laid on to the sink and boiler. The Government Inspector of Shipping may exempt—

(a) any ship of under 1,000 tons from the requirement of a hot-press ;

(b) any ship of under 500 tons from any of the requirements of this paragraph.

(5) All tables, lockers, dressers and the un-upholstered parts of chairs and settees in the mess room shall be made of polished hardwood, rustproof metal or other smooth and impervious material not likely to crack, warp or become corroded. All furniture provided in the mess room shall be so made as not to be likely to harbour vermin.

(6) The Government Inspector of Shipping may exempt—

(a) any passenger ship ;

(b) any ship engaged in the whaling industry

from the requirements of this regulation to the extent to which is satisfied that compliance therewith is unreasonable or impracticable in the circumstances.

Recreation  
spaces and  
Studies.

22.—(1) In every ship to which these regulations apply, being a ship of 3,000 tons or over employed otherwise than as a home trade ship, a smoking room shall be provided for the recreation of the officers, and shall not be combined with a mess room. The smoking room shall be provided with tables each having a top approximately 4 square feet in area and with tub chairs or easy chairs sufficient to accommodate at one time at least one-third of the number of officers for whose use the room is provided, and a bookcase.

(2) In every ship to which these regulations apply, being a home trade ship of 300 tons or over, or a ship of under 3,000 tons regularly employed otherwise than as a home trade ship, the mess room provided for the officers shall be available and furnished for use as a smoking room, unless a separate smoking room is provided for their use.

(3) In every ship to which these regulations apply recreation accommodation shall be provided in a mess room or elsewhere for ratings and shall be conveniently situated and appropriately furnished. Where such accommodation is provided elsewhere than in a mess room the seating provided shall be sufficient to accommodate at one time at least one-third of the number of ratings for whom that accommodation is provided. The Government Inspector of Shipping may exempt any whale catcher from the requirements of this paragraph.

(4) If more than two apprentices are accommodated in one sleeping room in a ship to which these regulations apply, a separate room shall be provided in the ship for their use as a study, unless another suitable place is available to them for purposes of study.

(5) In every ship to which these regulations apply, being a ship of 500 tons or over, a bookcase shall be provided for, and shall be accessible to, all members of the crew. The Government Inspector of Shipping may exempt any whale catcher from the requirements of this paragraph.

(6) In every ship to which these regulations apply space shall be provided on an open deck for the use of the crew for recreational purposes. The space shall be adequate in area (in so far as the size of the ship allows) having regard to the number of persons in the crew.

(7) Separate and appropriate recreation rooms shall be provided wherever required by the widely different national habits and customs of groups or persons in the crew.

23. In every ship to which these regulations apply, being a ship of 3,000 tons or over, and not being a ship used in treating whales or engaged in the carriage of persons employed in catching or treating whales, two separate rooms shall be provided for use as offices and shall be appropriately furnished for that purpose. One of such rooms shall be appropriated for use by the Chief Officer or the officers of the deck department, and the other for use by the Chief Engineer or for the officers of the engine room department. The office accommodation shall be in a room not used for any other purpose except study. Provided that an office appropriated solely for use by an individual officer may be combined with the day room of that officer.

Office  
Accom-  
modation.

24.—(1) In every class of ship to which these regulations apply each of the following classes of persons shall be provided with washing accommodation separate from that provided for the other classes—

Washing  
Accom-  
modation.

- (a) officers and apprentices ;
- (b) petty officers ;
- (c) ratings other than petty officers

Provided that the Government Inspector of Shipping may, in relation to any ship, permit any combination of the foregoing classes to be treated as one class for the purposes of these regulations, if he is satisfied that the circumstances so require.

(2) The washing accommodation shall be situated close to the sleeping accommodation of the persons for whose use it is appropriated. Provided that part of the washing accommodation for ratings of the engine room

department may be adjacent to the engine room and stokehold. The Government Inspector of Shipping may exempt any whale catcher from the requirements of this paragraph.

(3) Access to washing accommodation shall not be directly obtained from a mess room or a sleeping room and shall wherever reasonable and practicable in the circumstances be obtained from a passageway. Provided that access to washing accommodation may be obtained directly from not more than 2 sleeping rooms accommodating not more than 4 persons in all, if the washing accommodation is appropriated for use solely by the person or persons accommodated in those sleeping rooms.

(4) The following equipment shall be provided in the washing accommodation for each class of persons referred to in paragraph (1) of this regulation—

- one bath or shower for every 8 persons ;
- one wash-basin for every 6 persons ; and
- one mirror suitable for toilet purposes for every 6 persons.

and each of such classes shall be provided with at least one bath or shower and at least one wash-basin. One additional bath or shower exceeds by 4 or for any of such classes in which the total number of persons exceeds by 4 or more a multiple of 8, and one additional wash-basin shall be provided for any of such classes in which the number of persons exceeds by 3 or more a multiple of 6.

For the purposes of this paragraph—

- (a) a bath and shower combined shall be deemed to be only a bath
- (b) no account shall be taken, in determining the number of baths and showers required, of—
  - (i) any private bath or shower ; or
  - (ii) the persons for whose use a private bath or shower is appropriated ;
- (c) no account shall be taken, in determining the number of wash-basins required, of—
  - (i) any private wash-basin ; or
  - (ii) the persons for whose use a private wash-basin is appropriated ;
- (d) a bath, shower or wash-basin shall be deemed to be private if it is appropriated for the exclusive use of not more than four persons.

The Government Inspector of Shipping may exempt from any of the requirements of this paragraph—

- (i) any ship in which the crew number more than 100 ;
- (ii) any passenger ship engaged solely on voyages which are normally of less than 4 hours duration.

(5) The wash-basins shall be made of vitreous china or other material having a smooth and impervious surface not likely to crack, flake or become corroded. Every wash-basin provided in a passenger ship, being a basin fitted with hot and cold fresh-water taps, shall have a capacity of at least 1 gallon. Every other wash-basin provided in compliance with these regulations shall have a capacity of at least  $1\frac{1}{2}$  gallons. The capacity of wash-basins shall be measured for the purposes of this paragraph to a level at least  $1\frac{1}{2}$  inches below the rim of the bowl.

(6) Every bath shall be at least 4 feet 5 inches in internal length unless it is combined with a shower. Every bath shall be made of vitreous enamelled iron, or other material having a smooth and impervious surface not likely to crack, flake or become corroded. The floor area of every shower space shall be at least  $6\frac{1}{2}$  square feet, and each side of the space shall be at least 2 feet 6 inches long.

(7) Baths and showers provided for any class of persons shall be situated in or adjacent to a room containing wash-basins and provided for that class of person. Screening shall be provided to ensure privacy for any bath or shower which is in the same room as any wash-basin and any other bath or shower, unless the room is appropriated for the sole use of one person. The screening shall be made of robust and opaque material, and shall be rigid on at least three sides of every bath and shower space. The screening shall, wherever reasonable and practicable in the circumstances, enclose sufficient space to permit a person to dress and undress in comfort therein.

(8) Every wash-basin, bath and shower shall be fitted with an efficient and hygienic discharge system and, in particular, the waste pipes shall be fitted in a manner which will minimise the risk of obstruction and facilitate cleaning. Every shower space shall be fitted with a handrail, a kerb and individual drainage. Every bath and shower space shall be provided with a grating or mat.

(9) Spring-loaded draw-off taps for hot and cold fresh water shall be fitted on a bulkhead or partition in every wash room provided for ratings, unless taps for hot and cold fresh water are fitted to each wash-basin in that room. Draw-off taps for cold salt water shall be fitted in every such wash room unless there are other adequate means of washing down the room. The Government Inspector of Shipping may exempt—

(a) any ship of under 500 tons ; and

(b) any whale catcher

from the requirements of this paragraph relating to hot water taps to the extent to which he is satisfied that compliance therewith is unreasonable or impracticable in the circumstances.

(10) Nothing in this regulation shall apply to the washing accommodation forming part of a permanent hospital, and for the purposes of paragraph (4) thereof no account shall be taken of any wash-basin, bath or shower fitted in a permanent hospital.

25.—(1) In every ship to which these regulations apply there shall be available a supply of fresh water sufficient for the wash-basins, baths and showers fitted in compliance with these regulations. The supply shall be provided from tanks of a capacity of at least 10 gallons for each member of the crew for each day likely to elapse between successive replenishments of the water or by other equally efficient means. If service tanks are fitted for that purpose they shall be directly connected with the ship's main washing water or drinking water storage tanks. In ships of 1,000 tons or over any pumping necessary for the supply of fresh water shall be by mechanical power.

Supply of  
water to  
Washing  
Accommo-  
dation.

(2) Hot and cold water shall be laid on to all wash-basins, baths and showers fitted in compliance with these regulations. Provided that—

(a) in the case of a bath and shower combined, hot and cold fresh water shall be required to be laid on only to the bath or the shower ; and

(b) hot and cold fresh water shall not be required to be laid on to wash-basins provided for the sole use of ratings if it is laid on to spring-loaded draw-off taps in the same room in accordance with paragraph (9) of regulation 24 of these regulations.

Cold fresh water shall be laid on to any wash-basins which are additional to those required by these regulations and are fitted in sleeping rooms.

(3) The hot fresh water shall be at a constant temperature of at least 150° F. and shall be supplied by thermostatically controlled calorifiers or by other equally safe and efficient means. Every shower bath shall be provided with an anti-scalding mixture valve which shall be adjusted so that the temperature of the shower-water (whether salt or fresh) can be varied by the person using a shower over the range of temperatures between the ambient temperature and a temperature of between 95° F. and 105° F.

(4) The Government inspector of Shipping may exempt—

(a) any ship of under 500 tons ; and

(b) any whale catcher

from the requirement of this regulation relating to the supply of hot water to the extent to which he is satisfied that compliance therewith is unreasonable or impracticable in the circumstances.

Supply of  
Drinking  
Water.

26.—(1) In every ship to which these regulations apply a supply of drinking water shall be provided in the crew accommodation from tanks of an adequate capacity for the purpose having regard to the number of persons in the crew and the time likely to elapse between successive replenishment of the water, or by other equally efficient means. If service tanks are fitted for that purpose they shall be directly connected to the ship's main drinking water storage tanks. In ships of 3,000 tons or over any pumping necessary for the supply of drinking water in crew accommodation shall be by mechanical power.

(2) Cold drinking water shall be laid on to taps in the galleys and pantries, and in the mess rooms provided for those members of the crew for whose use service pantries are not provided.

(3) In every ship to which these regulations apply, being a ship of 1,000 tons or over employed otherwise than as a home trade ship, means shall be provided whereby the crew shall obtain access to drinking water which has been cooled by passing it through a cooling-tank or by other suitable means.

Laundry  
Facilities, etc.

27.—(1) In every ship to which these regulations apply, being a ship of 500 tons or over, washing troughs or other suitable facilities shall be provided to enable the crew to wash their clothes, and shall be adequate in size and sufficient in number for that purpose. Such troughs shall be made of or coated with hygienic and durable material having a smooth and impervious surface not likely to crack, flake or become corroded. The troughs or other facilities shall be situated in a room appropriated for use only as a laundry. Provided that the troughs or other facilities may be situated in the crew's washing accommodation if the provision of a separate laundry is unreasonable or impracticable in the circumstances. The troughs or other facilities shall be provided with an adequate supply of hot and cold fresh water, and shall be so arranged as to discharge overboard or into an enclosed tank served by a mechanically operated suction pump. The Government Inspector of Shipping may exempt any whale catcher from the requirements of this paragraph if he is satisfied that the wash-basins provided therein in compliance with regulation 24 of these regulations are suitable for washing clothes.

(2) In every ship to which these regulations apply, rooms for drying the crew's clothes shall be provided and shall be separate from sleeping rooms, mess rooms, recreation rooms, offices, store rooms, galleys, pantries and hospitals and shall be fitted with racks or rods with sufficient space having regard to the number of persons in the crew and the duration of the voyages on which the ship is intended to be engaged. The heating of such rooms shall

be capable of being controlled independently of the heating of any other space in the ship. The exhaust ventilation of such rooms shall be independent of all other spaces in the ship unless it is provided by a trunked mechanical ventilation system. Provided that in ships of under 500 tons drying cabinets or other suitable facilities may be substituted for a drying room.

(3) In every ship to which these regulations apply adequately ventilated compartments or lockers shall be provided for hanging oilskins and working clothes used by the crew. Separate compartments or lockers shall be provided for officers and ratings. The compartments or lockers shall be situated outside the sleeping rooms of the crew and in a position readily accessible therefrom. The Government Inspector of Shipping may exempt any ship of under 500 tons from any of the requirements of this paragraph.

28.—(1) In every ship to which these regulations apply each of the following classes of persons shall be provided with water closets separate from those provided for the other classes—

Water  
Closets.

- (a) officers and apprentices ;
- (b) petty officers ;
- (c) ratings other than petty officers.

Provided that the Government Inspector of Shipping may, in relation to any ship, permit any combination of the foregoing classes to be treated as one class for the purposes of this regulation if he is satisfied that the circumstances so require.

(2) Water closets shall be provided as follows—

(a) One for every 8 persons in each of the classes as aforesaid and each of such classes shall be provided with at least one water closet. One additional water closet shall be provided for any of such classes in which the total number of persons exceeds by 4 or more a multiple of 8.

Provided that—

(i) in determining the number of water closets required by this sub-paragraph no account shall be taken of—

- (a) any private water closet ; or
- (b) the persons for whose use a private water closet is appropriated ;

(ii) if the number of persons in any class exceeds 100, the number of water closets provided for that class shall be the greater of the following—

(a) 13, or

(b) 10, together with 4 per cent of the number of persons in excess of 100, calculated to the next following whole number.

For the purpose of this sub-paragraph a water closet shall be deemed to be private if it is appropriated for the sole use of not more than 4 persons. The Government Inspector of Shipping may exempt from the requirements of this sub-paragraph any passenger ship engaged solely in voyages the normal duration of which does not exceed 4 hours.

(b) In addition to the water closets required by sub-paragraph (a), there shall be provided such number of water closets, if any, as is required to increase the total number of water closets provided for the crew to the following—

In ships of 500 tons but under 800 tons	..	..	..	3
In ships of 800 tons but under 3,000 tons	..	..	..	4
In ships of 3,000 tons or over	..	..	..	6

- (c) In determining the number of water closets required by this paragraph no account shall be taken of any water closet forming part of a permanent hospital.
- (3) The water closets shall be situated close to the sleeping rooms of the persons for whom they are provided and in particular, a water closet shall be situated close to the sleeping rooms of any radio officers in the crew if such sleeping rooms are in a position remote from other sleeping rooms.
- (4) If the entrance to a water closet is from an open deck, the entrance shall, if practicable, be properly screened.
- (5) If the means of entry into water closets forming part of the crew accommodation is from a passageway leading to other parts of the crew accommodation, a lobby shall be provided at the entrance of the water closet or, where a lobby is not practicable, a self-closing door. Any doors between a water closet and a passageway shall be close fitting and without apertures. The Government Inspector of Shipping may exempt any ship from the requirement that the doors shall be close fitting and without apertures to the extent to which he is satisfied that the exhaust ventilation arrangements from the water closet render compliance therewith unnecessary.
- (6) Access to water closets shall not be obtained directly from a mess room or sleeping room. Provided that access to a water closet may be obtained directly from not more than two sleeping rooms altogether accommodating not more than four persons. If the persons so accommodated are three or four in number, the water closet pedestal shall be so screened as to ensure privacy.
- (7) Every water closet shall be completely enclosed by bulkheads and shall be provided with exhaust ventilation directly to the open air. Provided that a water closet may be separated by a partition consisting of steel or other opaque and rigid material open at the top and bottom from—
- (a) another water closet,
  - (b) a urinal, or
  - (c) washing accommodation if the water closet is served by a trunked mechanical ventilation system which effectively removes odours therefrom.
- (8) Every water closet shall be so constructed as to facilitate cleaning and not to harbour dirt or vermin.
- (9) Subject to the provisions of paragraph (10) of this regulation every water closet shall be provided with the following—
- (a) a water closet pedestal of single type with—
    - (i) a pan of white vitreous china or other suitable material ;
    - (ii) a seat of polished hardwood or other suitable material, with an opening of 4 inches at the front ;
    - (iii) a trap with a metal inspection plate ; and
    - (iv) an efficient ventilator connected to the outlet.
  - (b) An adequate flush of water, which shall be always available and supplied through self-closing non-concussive supply valves with a portable seating in metal which is not likely to become corroded.
  - (c) A soil pipe not less than 4 inches in diameter, so constructed as to facilitate cleaning and minimise the risk of obstruction ; the pipe shall have a direct overboard outfall fitted with a storm-valve, unless it is connected with a main sewage outfall by an efficient and hygienic system.
  - (d) A device for holding toilet paper.
  - (e) A handrail or grip.

(10) Every water closet provided for the exclusive use of such ratings as are referred to in paragraph (2) of regulation 39 of these regulations shall be designed and equipped in a manner suited to the national habits and customs of those ratings and in particular, shall be provided with—

- (a) a water closet pedestal of single type with a trapped pan of white vitreous china or other suitable material;
- (b) an arrangement which automatically flushes the pan at intervals not exceeding 5 minutes and provides a continuous trickle of water; and
- (c) a soil pipe such as is referred to in sub-paragraph (c) of paragraph (9) of this regulation; the pipe shall be fitted with a metal inspection plate and efficient ventilation.

The Government Inspector of Shipping may exempt any ship from the requirements of this paragraph if he is satisfied that the water closets provided for the aforesaid ratings comply with the requirements of paragraph (9) of this regulation and have been properly adapted so as to be suited to the national habits and customs of those ratings.

(11) The provisions of this regulation shall not apply to water closets forming part of a permanent hospital.

29.—(1) Every ship to which these regulations apply shall be provided with a galley for the preparation of food for the crew, unless the circumstances are such that no members of the crew are required to mess on board.

Galleys.

(2) The galley shall be situated as near as may be to the mess rooms provided for the crew and any necessary equipment shall be provided to enable food to be served hot in the mess rooms under all weather conditions.

(3) The galley shall be situated in a position which will prevent, as far as is practicable, the entry into the galley of coal dust from coal chutes or bunker hatchways.

(4) There shall be no direct opening between the galley and any sleeping room. The Government Inspector of Shipping may exempt any ship of under 500 tons from the requirements of this paragraph.

(5) Any galley situated on an open deck shall be provided with weather doors which are horizontally divided into halves, so that the upper half can be opened independently of the lower half, if such a division is necessary for the lighting, ventilation or privacy of the galley or for the service of food therefrom.

(6) Every galley shall, so far as is reasonable and practicable, be lighted by natural lighting from all the sides and from overhead.

(7) Every galley shall be provided with at least three fixed points for artificial lighting, one of which shall be situated close to a cooking range required by this regulation. The Government Inspector of Shipping may exempt any ship of under 1,000 tons from the requirements of this paragraph.

(8) If the galley is situated on an open deck, openings shall be cut in the sides and ends of the galley for ventilation purposes and shall be fitted with dust-tight shutters made of steel or other suitable material and permanently attached to the structure of the galley. The Government Inspector of Shipping may exempt any ship from the requirements of this paragraph if he is satisfied that compliance therewith is unreasonable or impracticable in the circumstances.

(9) Every galley shall be provided with exhaust fans which discharge the fumes into the open air. The Government Inspector of Shipping may exempt from the requirement of this paragraph—

(a) any ship of under 1,000 tons ;

(b) any other ship, if he is satisfied that the galley is so situated that the fumes therefrom can discharge only into the open air.

(10) The floor of the galley shall be provided with gutters and with scuppers which shall be led overboard or to an enclosed tank served by a mechanically operated suction pump. The position and number of the gutters shall be such as will ensure the efficient drainage of the floor.

(11) The cooking appliances in the galley shall be arranged in a manner which will facilitate the cleaning of the galley.

(12) All cupboards and dressers in the galley shall be made of material which is impervious to dirt and moisture and can easily be kept clean. All metal parts of the cupboards and dressers shall be rustproof. The cupboards and dressers shall be so made as not to be likely to harbour dirt or vermin. The bottoms of all cupboards and dressers shall either be flush with the deck or shall be so fitted as to enable the deck space beneath them to be readily accessible for cleaning.

(13) Every galley shall be provided with such equipment as will enable food in sufficient quantity to be properly and readily prepared for the persons whom the galley is intended to serve, and the cooking utensils to be hygienically cleaned.

(14) Without prejudice to the generality of the preceding paragraph—

(a) Every galley shall be provided with one or more cooking appliances with—

(i) a total oven capacity, suitable for roasting and baking, of at least  $\frac{1}{4}$  cubic foot, and

(ii) an area of range top-plate or boiling table, amounting to at least  $\frac{1}{8}$  square foot.

for each person whom the galley is intended to serve. The Government Inspector of Shipping may exempt any ship from any of the requirements of this sub-paragraph in so far as they relate to cooking appliances in galleys intended to serve more than 60 persons, or to the area of any top-plate or boiling table in which electricity or heat-storage is employed, or to the area of any appliance which the Government Inspector of Shipping is satisfied is of unusual design ;

(b) Every galley shall be provided with at least the number of ovens and fire-grates specified in the following table—

<i>Number of persons whom the galley is intended to serve</i>	<i>Number of Ovens</i>	<i>Number of Fire-Grates</i>
Not more than 20 .. .. .	1	1
More than 20, but not more than 30 .. .. .	2	1
More than 30, but not more than 60 .. .. .	2	2
More than 60 .. .. .	3	2

Provided that no fire-grate shall be required in a galley fitted only with electric or gas cooking appliances. The Government Inspector of Shipping may exempt any ship from the requirement of a second fire-grate if he is

satisfied that adequate heat is readily available from one fire-grate and that adequate provision of spare parts is made for such grate and for any equipment necessary for its proper operation.

(c) The top-plate of every cooking range shall be at a height which will enable it to be conveniently used by a person of normal height standing on the floor of the galley, unless a separate boiling table is provided at such a height. The Government Inspector of Shipping may exempt any ship from the requirements of this paragraph, if he is satisfied that compliance therewith is unnecessary by reason of the voyages on which the ship is intended to be engaged or the national habits and customs of the persons whom the galley is intended to serve.

(15) Salt water taps shall not be fitted over a sink in any galley or other place in which food may be prepared for the crew. Hot and cold fresh water shall be laid on to a sink in the galley for washing-up purposes. A connection shall be provided on a water pipe in the galley, and shall be suitable for the connection of a hose with which the floor may be scoured.

30.—(1) In every ship to which these regulations apply, not being a ship in which each member of the crew provides his own food, one or more store rooms shall be provided for the storage of dry provisions for the crew. Such rooms shall be fitted with sufficient shelves, cupboards and bins having regard to the maximum period likely to elapse between successive replenishments of stores and to the maximum number of persons for whom food is to be served.

Dry  
Provision  
store rooms.

(2) Every dry provision store room shall be enclosed by bulkheads constructed of steel or other suitable material.

(3) Access to every dry provision store room shall be obtained from a passageway, galley, pantry or another store room, or from a position on an open deck which, in so far as is reasonable and practicable in the circumstances, shall be a protected position.

(4) Every dry provision store room shall be so situated, constructed and ventilated as to avoid deterioration of the stores through heat, draught, condensation or infestation by insects or vermin.

(5) Without prejudice to the generality of the foregoing paragraph, no dry provision store room shall be situated over a boiler room or any other space in which heat is generated or shall adjoin a galley or machinery casing. The Government Inspector of Shipping may exempt any ship from the requirements of this paragraph if he is satisfied that compliance therewith is unreasonable or impracticable in the circumstances and that the dry provision store room is adequately insulated.

(6) No part of a dry provision store room shall be used for the storage of bedding or textiles.

31.—(1) In every ship to which these regulations apply, refrigerating equipment and cold store rooms shall be provided and shall be, having regard to the period likely to elapse between successive replenishments of stores, adequate for the storage of perishable provisions for the crew. The Government Inspector of Shipping may exempt any ship of under 1,000 tons from the requirements of this paragraph if he is satisfied that the ship is provided with adequate alternative equipment for the storage of perishable provisions.

Cold Store  
Rooms and  
Refrigerating  
Equipment.

(2) Access to every cold store room shall be obtained from a passageway, galley or pantry or from another store room.

32.—(1) Every ship to which these regulations apply, being a ship (other than a whale catcher or a tug) which is intended to be at sea on any occasion for a continuous period of more than three days with a crew of 15 or more persons, shall be provided with a space appropriated for use as a permanent hospital for the crew. The space so appropriated shall not at any time be used for any purpose other than for the treatment of sick persons. The Government Inspector of Shipping may exempt from the requirement of this paragraph any ship engaged only on voyages or excursions wholly between ports within Nigeria.

(2) In every other ship to which these regulations apply a room shall be appropriated for use, when necessary, as a temporary hospital. When such room is in use as a hospital it shall not be used for any purpose other than the treatment of sick persons. The Government Inspector of Shipping may exempt any ship from the requirement of this paragraph if he is satisfied that compliance therewith is unnecessary in the circumstances.

(3) Every hospital, whether permanent or temporary, shall be situated in a position which will ensure the greatest possible quiet and comfort for the patients. The hospital shall be readily accessible and, in the case of a ship not carrying a duly qualified medical practitioner or duly qualified nurse exclusively employed as a member of the crew, shall be so situated as to be readily accessible from the sleeping accommodation of the Master of the ship or of a person appointed by the Master to take charge of the patients. The hospital shall be so situated as to facilitate the proper treatment of patients in all weathers.

(4) The minimum width of the entrance to every permanent hospital shall be 30 inches or as near thereto as is practicable in the circumstances. The hospital shall be so arranged that a stretcher can easily be carried into the hospital and placed alongside at least one single-tier bed therein.

(5) The floor covering in every permanent hospital shall, as far as is practicable be free from joints.

(6) Every permanent hospital shall include a hospital ward fitted on at least two sides with side scuttles at least 12 inches in diameter. The side scuttles shall be capable of being opened. Provided that, if it is not practicable to fit a side scuttle on two sides of the hospital ward, a skylight, capable of being opened and of as large a size as is practicable, may be substituted for a side scuttle on one side of the ward. All side scuttles in the hospital, and any skylight therein which is exposed to the direct rays of the sun, shall be provided with curtains, blinds or jalousies. The Government Inspector of Shipping may exempt from the requirements of this paragraph—

(a) any ship of under 1,000 tons ; and

(b) any other ship, if he is satisfied that the permanent hospital therein is fully air-conditioned or served by a trunked mechanical ventilation system.

(7) In addition to any mechanical ventilation required by regulation 13 of these regulations, every permanent hospital shall be provided with adequate natural supply and exhaust ventilation to the open air by means of ventilators, independent of the ventilators provided for any other space in the ship. The Government Inspector of Shipping may exempt any ship from the requirement of this regulation if he is satisfied that compliance therewith is unreasonable or impracticable in the circumstances.

(8) Every permanent hospital shall be provided with an electric fan, unless it is served by a trunked mechanical ventilation system.

(9) Any radiators in a permanent hospital shall be installed as far away as is practicable from the heads of beds.

(10) In addition to the lighting required by regulation 12 of these regulations, every permanent hospital shall be provided with a portable electric lamp and with such accessories as are necessary for its use.

(11) In every ship which is required by this regulation to be provided with a permanent hospital at least one bed shall be provided in a hospital ward for every 50, or fraction of 50, members of the crew. The Government Inspector of Shipping may exempt from the requirement of this paragraph any ship carrying more than 300 persons, to the extent to which he is satisfied that compliance therewith is unreasonable or impracticable in the circumstances.

(12) At least one single-tier bed shall be provided in a ward in every permanent hospital. The bed shall, if practicable, be so arranged as to be accessible from both sides and from the foot. If any beds in the ward are arranged in double tiers, the upper tier shall be hinged or shall be removable. Subject to the foregoing provisions of this paragraph, the provisions of paragraphs (2) to (9) (a) inclusive and paragraph (10) of regulation 18 of these regulations shall apply to hospital beds as they apply to beds in a sleeping room.

(13) In every ward in a permanent hospital one of each of the following items of equipment shall be provided for each bed in the hospital ward and shall be within reach of that bed—

- (a) a locker approximately 1 foot square by 2 feet high, and fitted with a flat top and a shelf;
- (b) a water bottle; and
- (c) a tumbler.

(14) In every ward in a permanent hospital the following items of equipment shall be provided—

- (a) seats adequate in number, having regard to the number of beds in the ward;
- (b) a clothes locker additional to that required by paragraph (13) of this regulation, and complying with the specifications set forth in sub-paragraph (a) (ii) of paragraph (1) of regulation 19 of these regulations;
- (c) a box cover which will conceal a bed-pan; and
- (d) electric bell-pushes so arranged as to be within reach of each bed and communicating with the sleeping room of the person in charge of the patients.

(15) A wash-basin having a capacity of at least  $1\frac{1}{2}$  gallons shall be fitted in every permanent hospital. In ships of 5,000 tons or over a bath at least 4 feet 5 inches in internal length shall be fitted in washing accommodation forming part of the hospital and adjacent to the hospital ward. The wash-basin and bath shall be made of or coated with hygienic and durable material having a smooth and impervious surface not likely to crack, flake or become corroded. They shall be fitted with an efficient and hygienic discharge system separate, if practicable, from any other discharge system in the ship and in particular the waste pipes shall be fitted in a manner which will

facilitate cleaning. A scupper at least 2 inches in diameter shall be fitted in the lowest part of any room (other than a ward) which contains such wash-basin or bath. The Government Inspector of Shipping may exempt any ship from the requirement of a bath in a permanent hospital, if he is satisfied that compliance therewith is unreasonable or impracticable in the circumstances.

(16) A water closet pedestal shall be fitted as part of every permanent hospital and it shall comply with the following specifications—

(a) it shall be fitted either in a water closet or in washing accommodation forming part of the hospital ;

(b) access to the water closet pedestal (or washing accommodation, as the case may be) shall be obtained directly from the hospital ward or from a lobby forming part of the hospital. The Government Inspector of Shipping may exempt any ship from the requirement of this sub-paragraph if he is satisfied that compliance therewith is impracticable in the circumstances, and that the water closet forming part of the hospital is situated sufficiently near to the ward ;

(c) the room in which the water closet is installed shall be provided with a gas-tight, self-closing door unless it is served by a mechanical system of exhaust ventilation, and shall be so constructed as to facilitate cleaning and not to harbour dirt or vermin ;

(d) such room shall be ventilated in the manner specified in paragraph (7) of regulation 28 of these regulations and shall comply with the requirements of paragraph (9) or (10) of the said regulation whichever shall be applicable in the circumstances.

(17) In all ships engaged whether temporarily or permanently on voyages to the Persian Gulf area between the months of May and October inclusive, consideration shall, wherever practicable, be given to the provision in every hospital in every such ship for a means of airconditioning of sufficient capacity to maintain 84° fahrenheit (dry bulb) with 52% relative humidity when the ambient conditions are 90° fahrenheit (dry bulb) and 78% relative humidity. This may be by independent unit.

(18) The Government Inspector of Shipping may exempt any ship of under 500 tons from any of the requirements of this regulation.

33.—(1) In every ship to which these regulations apply a medical cabinet shall be provided in a position adjacent to the permanent hospital, if any, required by regulation 32 of these regulations or near to the sleeping room of the person in charge of sick persons on board. The medical cabinet shall be fitted in a position which is remote from all sources of heat, and will remain dry.

(2) The medical cabinet shall be of a size, design and construction suitable for storing the medicines, medical stores and the book of instruction provided in the ship for the benefit of the seamen on board. In particular, the medical cabinet shall be provided with the following—

(a) an outer door fitted with an efficient lock ;

(b) an inner cupboard fitted with a door and a lock which shall be incapable of being opened by the key to the lock referred to in sub-paragraph (a) of this paragraph ; such inner cupboard shall be used solely for the storage of poisonous drugs ;

(c) shelves so constructed as to facilitate the identification of medicines stored thereon ;

(d) a dispensing counter or dispensing table, in either case with a surface which can easily be kept clean ;

(e) at least two drawers suitable for the storage of medical stores and used solely for that purpose ;

(f) fittings which will enable hot water bottles to be carried in a hanging position ;

(g) a rack suitable for holding devices for measuring medicines ;

(h) a book containing readily understandable instructions for the use of medicines and medical stores provided for the crew, unless the ship carries a duly qualified medical practitioner as a member of the crew.

The Government Inspector of Shipping may exempt any ship from the requirements of this paragraph to the extent to which he is satisfied that compliance therewith is impracticable having regard to the size or intended service of the ship.

(3) The medical cabinet shall be lighted by an electric light which shall be inside or immediately outside the cabinet, and which will enable all the contents of the cabinet to be clearly seen in the absence of light from any other source.

(4) The medical cabinet and the place in which it is fitted shall be so ventilated as to avoid deterioration of the contents of the cabinet.

(5) The Government Inspector of Shipping may exempt from any of the requirements of this regulation any ship of under 500 tons, being a ship wholly engaged on voyages or excursions between ports in Nigeria only, if he is satisfied that compliance therewith is unreasonable or impracticable in the circumstances.

34.—(1) In every ship to which these regulations apply, being a ship regularly engaged on voyages to any port to which this regulation relates, the crew accommodation, other than galleys, store rooms and recreation spaces on the open deck shall be provided with protection against the admission of mosquitoes. Such protection shall be provided by means of screens of rust-proof wire or other suitable material which shall be fitted to all side scuttles, natural ventilators, skylights, and doors leading to the open deck.

Protection  
from  
Mosquitoes.

(2) Any door to which such screens are fitted, being a door at the entrance to a permanent or temporary hospital, shall be of a self-closing type.

(3) The ports to which this regulation relates are the following :—

(a) Ports between 20° North Latitude and 20° South Latitude on the coasts of—

(i) Asia, including the East Indian Archipelago and the Philippine Islands, but excluding Aden, Bombay, Madras, Vizagapatam, Colombo, Trincomalee, Singapore, Penang and Port Swettenham ;

(ii) Africa, excluding Port Sudan and Massawa ;

(iii) New Guinea, New Britain, New Ireland, New Hebrides and the Solomon Islands ;

(b) Ports on the coasts of Madagascar.

(4) Any ship the crew accommodation of which is fully air conditioned may not be required to comply with all of the requirements of sub-paragraph (1) of this regulation provided that special locking arrangements are incorporated for all side scuttles and windows. Openings which are required by these Rules as means of escape or those forming permanent openings to the open deck, must however, at all times, be adequately fitted with screens.

crew accommodation in every ship to which these regulations shall be maintained in a clean and habitable condition, and all installations required by these regulations shall be maintained in good order. Every part of the crew accommodation (not being for the use of persons from whom that part of the accommodation is appropriated, and in particular no cargo shall be kept in any part of the accommodation.)

The Master of the ship or an officer appointed by him for the purpose shall be accompanied on the inspection by one or more members of the crew. The Master of the ship shall cause to be entered in the special log book a record of—

1. The time and date of the inspection ;  
2. The names and ranks of the persons making the inspection ;  
3. The particulars of any respects in which the crew accommodation or any part thereof was found by any of the persons making the inspection to not comply with these regulations.

Crew accommodation in every ship to which these regulations apply shall be inspected by a surveyor of ships whenever—

1. The ship is registered or re-registered in Nigeria ;  
2. Any part of the crew accommodation in the ship undergoes substantial repairs ;  
3. The number of persons accommodated in any sleeping room is more than above that marked in accordance with paragraph (1) of regulation 10 of these regulations ;

4. In the opinion of a surveyor there is reason to believe (whether or not as a consequence of a complaint) that any of the provisions of these regulations has been contravened in respect of that ship, or that any other person subject to which the Government Inspector of Shipping has jurisdiction is in the ship from a requirement of these regulations has not been complied with.

5. A request for an inspection of the crew accommodation has been made to the Government Inspector of Shipping or to a surveyor of ships by the owner or on behalf of the owner of the ship or of any organisation which is recognised by the Government Inspector of Shipping to be representative of the owners of Nigerian ships or the seamen concerned ; or

6. A complaint has been lodged with a surveyor of ships or with a surveyor of shipping master, which complies with the following conditions—

(a) The complaint shall be in writing, signed by one member of the crew in the case of a ship of under 1,000 tons, and by three members of the crew in the case of any other ship ;

(b) The complaint shall specify the respects in which it is alleged that the crew accommodation in the ship does not comply with these regulations ;

(c) The complaint shall be lodged without undue delay ;

(d) The complaint shall be lodged at least 24 hours before the ship is due to sail, unless the ship is in port for less than 24 hours.

37. In respect of any inspection of a ship carried out for the purposes of sub-paragraphs (b), (c), (d), (e), or (f) of regulation 36 of these regulations, the following fee shall be paid—

Fees.

For each visit to the ship .. .. .	£	s	d
Maximum total fee in each case .. .. .	3	15	0
	15	0	0

Provided that no fee shall be payable in respect of an inspection made in pursuance of the aforesaid sub-paragraph (f) if the Government Inspector of Shipping is satisfied that the inspection was made in consequence of an unjustified complaint.

38.—(1) No accommodation provided in compliance with these regulations shall be used, or appropriated for use, by passengers. No galley or store room provided in compliance with these regulations shall be used, or appropriated for use, for the preparation or storage of food for passengers.

Accommodation shared with passengers.

(2) The Government Inspector of Shipping may exempt any ship from the requirements of these regulations, not being requirements relating to sleeping rooms, or office accommodation, to the extent to which he is satisfied that accommodation equal or superior in standard to the accommodation required by these regulations is available for the use of service of the crew in common with passengers.

39.—(1) The Government Inspector of Shipping may exempt—

- (a) any ship while under construction ;
- (b) any ship while undergoing trials ;
- (c) any ship of under 200 tons ;
- (d) any tug ;
- (e) any ship which, in his opinion, is primarily employed in a harbour, river, estuary, lake or canal ;
- (f) any passenger steamer in respect of which there is in force a passenger certificate of Class III or IV ; and
- (g) any ship engaged in the whaling industry ;

Additional Exemptions.

from the requirements of these regulations to the extent to which he is satisfied that compliance therewith is unreasonable or impracticable in the circumstances.

(2) The Government Inspector of Shipping may exempt from the requirements of these Regulations any ship in which by reason of the type of ratings employed, it is necessary to employ a substantially greater number of ratings than would normally be required, if he is satisfied that the ship is provided with crew accommodation for such ratings that is suited to their distinctive national habits and customs and, in the case of mess room, sanitary accommodation and hospitals, is equal or comparable in standard to the crew accommodation required by these regulations.

(3) The Government Inspector of Shipping may, after consultation with the owners of the ship, or such organisation or organisations as appear to him to be representative of owners of Nigerian ships, and with such organisation or organisations as appear to him to be representative of seamen employed in Nigerian ships, exempt any ship from any of the requirements of these regulations if he is satisfied that corresponding advantages are provided in the ship so that the crew accommodation, considered as a whole is equivalent or superior in standard to that required by these regulations.

40. In the measurement of a ship to which these regulations apply for the purpose of ascertaining her registered tonnage no deduction shall be allowed for—

- (a) any space appropriated for the storage of fresh water for the use of the crew;
- (b) any excess in volume of the space appropriated for the storage of provisions (other than fresh water) for the crew over 15 per cent of the total volume of the other spaces provided in the ship as crew accommodation and accommodation for the Master of the ship; and
- (c) any space forming part of the crew accommodation which has not been first included in the measurement of the ship's tonnage.

*Regulations 3 and 13 (3)*

## FIRST SCHEDULE

### TRUNKED MECHANICAL VENTILATION SYSTEM

1. The trunked mechanical ventilation system referred to in Regulation 3 and paragraph (3) of Regulation 13 of these Regulations (in this Schedule referred to as "the system") shall, in relation to the spaces specified in the second column of Table I annexed hereto, be capable of the respective standards of performance specified in the third or fourth column of that Table, whichever standard shall be the higher in the circumstances. Provided that nothing in Table I shall be taken to relate to a space specified in the second column of Table II annexed hereto.
2. The system shall, in relation to the spaces specified in the second column of Table II, be capable of the respective standards of performance specified in third and fourth columns of that Table.
3. If any store room is served by a fan which provides warmed air for any other space, the store room shall be provided with ventilation trunking separate from that serving such other space.
4. The clear area of the exhaust openings provided in conjunction with the system shall be sufficient to ensure that the velocity of air at each exhaust opening does not exceed 1,000 feet per minute when the system is in operation.
5. The speed of every supply fan forming part of the system shall be capable of being varied, where direct current motors are used.
6. The system shall be quiet in operation.
7. All trunking forming part of the system shall be provided with non-return flaps where such flaps are necessary for the exclusion of effluvia and the preservation of the health of the crew.
8. If the system is designed to circulate heated air as the sole means of heating the crew accommodation, the system shall be sub-divided into sections which can be separately controlled to the extent necessary to enable a comfortable temperature to be maintained in all parts of the crew accommodation.

TABLE 1

1 Category	2 Space	3 Fresh air changes per hour	4 Volume of fresh air, in cubic feet per minute, for each person likely to use the room at any one time
A	Rooms (other than rooms in Category C) in deck houses above the upper or shelter deck :— (1) outside rooms (other than rooms adjoining machinery casing) (2) inside rooms and rooms adjoining machinery casing ..	10 15	50 50
B	Rooms (other than rooms in Category C) in side-to-side superstructures above the upper or shelter deck :— (1) outside rooms (other than rooms adjoining machinery casing) (2) inside rooms and rooms adjoining machinery casing ..	12 15	50 50
C	Mess rooms, smoking rooms and recreation rooms (in each case above the upper or shelter deck) :— (1) not adjoining machinery casing .. .. . (2) adjoining machinery casing	15 18	25 (a) 25 (a)
D	Passageways adjoining machinery casings .. .. .	4	—
E	Rooms in between decks (including shelter between decks) of ships propelled by internal combustion machinery :— (1) Rooms clear of machinery casing .. .. . (2) Rooms abreast of but not adjoining machinery casing .. (3) Rooms adjoining machinery casing (other than mess rooms, smoking rooms and recreation rooms) .. .. . (4) Mess rooms, smoking rooms and recreation rooms (in each case adjoining machinery casing) ..	12 12 15 18	50 50 60 25
F	Rooms in between decks (including shelter between decks) of steamships :— (1) Rooms clear of machinery casing .. .. . (2) Rooms abreast of, but not adjoining machinery casing .. (3) Rooms immediately above machinery casing or abreast of and adjoining machinery casing (other than mess rooms, smoking rooms and recreation rooms) .. .. . (4) Mess rooms, smoking rooms and recreation rooms (in each case adjoining machinery casing) ..	12 15 18 20	50 60 60 30 (b)

(a) Whatever the number of persons likely to use the room at any one time, the total volume of fresh air per minute shall not be required to be such as would result in more than 20 fresh changes per hour.

(b) Whatever the number of persons likely to use the room at any one time, the total volume of fresh air per minute shall not be required to be such as would result more than 25 fresh air changes per hour.

TABLE II

1 Cate- gory	2 Space	3 Fresh air changes per hour	
		Supply	Exhaust
		20 (c) (d)	40 (d)
G	Galleys .. .. .		
H	Sanitary accommodation, drying rooms and pantries .. .. .	10	—
J	Wards in permanent hospitals ..	12 or such greater number as would result in the supply of not less than 50 cubic feet of fresh air per minute for each bed in the room.	—
K	Dry provision store rooms .. .. .	Not less than 10 (e) and not more than 20.	—

(c) 15, if at least two sides of the galley are exposed to the weather.

(d) The Government Inspector of Shipping may exempt any ship from these requirements to the extent that he is satisfied that compliance therewith is unnecessary by reason of the insulation of the equipment in the galley, or by reason of the size of the galley.

(e) Subject to the provisions of Regulation 30 (4).

SECOND SCHEDULE

Regulations 8 (2)  
and 9 (3)

B 235

DECK SHEATHINGS

1. The material referred to in paragraph (2) of Regulation 8 and paragraph (3) of Regulation 9 of these Regulations (in this Schedule referred to as "the material") shall comply with the following requirements:—

(a) **Foothold.** The material, whether wet or dry, shall provide a good foothold.

(b) **Thermal Insulation.**

(i) If the material covers a deck exposed to the weather, it shall provide thermal insulation not less than that provided by a wooden deck  $2\frac{1}{4}$  inches thick.

(ii) If the material covers any other deck, it shall provide a warm and comfortable surface.

(c) **Fire Resistance.** The material shall be such as will not readily ignite in the position in which it is laid.

(d) **Water Absorption.** The material shall be such that, after being immersed in water for a period of 48 hours, the moisture content of the material will not exceed 7 per cent of its dry weight. The Government Inspector of Shipping may exempt any ship from the requirement of this sub-paragraph.

(e) **Adhesion.** The material shall be so laid as to adhere closely under all conditions of service to the surface on which it is laid.

(f) **Non-corrosion.** The material shall not contain any substance which may cause corrosion of the deck on which it is laid, unless the deck is effectively protected from corrosion by a coating applied for that purpose.

(g) **Danger to persons.** The material shall be such as will not produce any injurious effect upon persons who may come in contact with it.

(h) **Resistance to wear and weather.** The material shall be sufficiently hard and strong to withstand all conditions of service and shall be sufficiently flexible to prevent cracking under those conditions.

2. If the material is laid in a permanent hospital, it shall be material not likely to be damaged by surgical spirit or other liquids which may be used in the hospital.

3. If the material is laid on the crown of an oil fuel tank, the material shall be such that if it is immersed in fuel oil for a period of 24 hours at a temperature of 150°F. the weight of the material will not increase by more than 1 per cent and the material will not be penetrated by the oil.

## THIRD SCHEDULE

Regulation 8 (2)

## INSULATING MATERIAL FOR THE UNDERSIDE OF DECKS

The insulating material referred to in paragraph (2) of Regulation 8 of these Regulations (in this Schedule referred to as "the material") shall comply with the following requirements :—

- (a) Thermal Insulation. The material shall provide thermal insulation not less than that provided by a wooden deck  $2\frac{1}{4}$  in. thick.
- (b) Fire Resistance. The material shall be such as will not readily ignite in the position in which it is laid.
- (c) Adhesion. The material shall be so laid as to adhere closely under all conditions of service to the deck under which it is laid.
- (a) Non-corrosion. The material shall not contain any substance which may cause corrosion of the deck under which it is laid, unless the deck is effectively protected from corrosion by a coating applied for that purpose.

## FOURTH SCHEDULE

Regulation 16

## MARKING

## PART I

## MARKINGS FOR SLEEPING ROOMS

- Certified for (a)\* seamen.
- Certified for (b)\* seamen.
- Certified for (a)\* seamen or (b)\* seamen.

## PART II

## MARKINGS FOR SPACES OTHER THAN SLEEPING ROOMS

- Certified for Chief Officer (c)\*
- Certified for Officers.
- Certified for Petty Officers.
- Certified for Apprentices.
- Certified for Crew.

(a)\* There shall here be inserted the maximum number of seamen who may be accommodated in the room in accordance with these Regulations when it is not appropriated for use solely by such ratings as are referred to in Regulation 39 (2).

(b)\* There shall here be inserted the maximum number of seamen who may be accommodated in the room in accordance with these Regulations when it is appropriated for use solely by such ratings as are referred to in Regulation 39 (2).

(c)\* In the case of a room intended for the sole use of any other Officer the rank of that Officer shall here be substituted.

MADE at Lagos this 11th day of June, 1964.

R. A. NJOKU,  
*Federal Minister of Transport*

#### EXPLANATORY NOTE

These regulations govern the crew accommodation to be provided in sea-going ships registered in Nigeria (other than fishing boats, and, pleasure yachts) and implement in this respect Convention No. 68 concerning Food and Catering for Crews on Board Ship adopted by the International Labour Conference at Seattle in 1946 and Convention No. 92 concerning Crew Accommodation on Board Ship adopted by the International Labour Conference at Geneva in 1949.



MERCHANT SHIPPING ACT, 1962  
Merchant Shipping (Accepted Load Line Convention  
Certificates) Order, 1964

Commencement : 2nd July, 1964

In exercise of the powers conferred by section 216 of the Merchant Shipping Act, 1962, the Minister hereby makes the following Order—

1. This Order may be cited as the Merchant Shipping (Accepted Load Line Convention Certificates) Order, 1964.
2. Every Load Line Convention Certificate in respect of a Load Line Convention ship, not being a Nigerian ship, which complies with such of the requirements of this Order as apply to it in the circumstances shall be accepted as having the same force as the corresponding certificate issued by the Minister under the Act.
3. Subject to the provisions of this Order, a Load Line Convention Certificate shall be in the form set forth in the First Schedule hereto, or as adapted to suit the needs of special classes of ships by the Government Inspector of Shipping.
4. Every Load Line Convention Certificate shall be by its terms applicable to the voyage in respect of which a clearance or transire is demanded and to the trade in which the ship is for the time being engaged.
5. Every Load Line Convention Certificate shall show by its terms that it was issued by or under the authority of the Government of the country in which the ship is registered or to which she belongs or that it was issued at the request of that Government by the Minister or by or under the authority of the Government of any other country to which the certificate was issued at applies. The certificate shall be in English if issued by the authority of any other case in the official language of the country of the Minister and in any other case in the official language of the country of the Minister and in whether by handwriting, typescript or otherwise in the blank spaces inserted, for that purpose shall be in Roman characters and Arabic figures.
6. Every Load Line Convention Certificate shall show the date on which it was issued and the period of its validity, which shall not exceed five years from the date of issue, subject to annual inspections to ensure that the terms are being complied with. Such certificates may thereafter be extended for a further period of five years if the ship passes a full load line survey :  
Provided that if a duly authorised officer of the country in which the ship is registered or to which she belongs has extended the period of validity of any certificate by a period not exceeding either five months for the specific purpose of enabling the ship to return to that country, or one month for any other purpose, such certificate shall be accepted during the period of any such extension if the ship complies with any other requirements of this Order which apply to it in the circumstances.
7. It is hereby declared that the countries listed in the Second Schedule hereto are recognised as having accepted the provisions of the International Load Line Convention.

Citation

Certificates accepted.

Form of Certificate. First Schedule.

Certificates to be applicable to current voyage.

Certificate to show by whom issued, etc.

Certificate to show date and period of validity, etc.

Countries which have accepted convention.

FIRST SCHEDULE

INTERNATIONAL LOAD LINE CERTIFICATE

Issued under the authority of the Government of .....  
under the provisions of the International Load Line Convention, 1930.

Ship ..... Distinctive  
Port of Registry ..... Number or  
Gross Tonnage ..... Letters .....

Freeboard from Deck Line

Load Line

Tropical ..... (a) ..... above (b)

Summer ..... (b) Upper edge of line through  
centre of disc.

Winter ..... (c) .....below (b)

Winter in North Atlantic..... (d) .....below (b)

Allowance for Fresh Water for all freeboards .....  
The upper edge of the deck line from which these freeboards are measured  
is .....inches above the top of the.....deck  
at side.



THIS IS TO CERTIFY that this ship has been surveyed and the freeboards and  
load lines shown above have been assigned in accordance with the Convention.

This certificate remains in force until .....

Issued at ..... on the.....  
day of .....

Here follow the signature or seal and the description of the authority  
issuing the certificate.

*Note* :—Where sea-going steamers navigate a river or inland water, deeper loading is  
permitted corresponding to the weight of fuel, etc., required for consumption between  
the point of departure and the open sea.

FIRST SCHEDULE—*continued*

B 241

The provisions of the Convention being fully complied with by this ship,  
this certificate is renewed until .....

Place ..... Date .....

Signature or seal and description of authority.

The provisions of the Convention being fully complied with by this ship,  
this certificate is renewed until .....

Place ..... Date .....

Signature or seal and description of authority.

The provisions of the Convention being fully complied with by this ship,  
this certificate is renewed until .....

Place ..... Date .....

Signature or seal and description of authority.

SECOND SCHEDULE

List of Governments which are parties to the International Convention  
Respecting Loadlines, 1930, and of the Territories to which the Convention  
has been applied.

<i>Government</i>	<i>Effective Date</i>
Argentina .. .. .	19th January, 1936
Australia .. .. .	17th May, 1936
Belgium .. .. .	29th August, 1935
Brazil .. .. .	31st March, 1938
Bulgaria .. .. .	4th December, 1933
Burma .. .. .	1st January, 1935
Cambodia .. .. .	15th January, 1939
Cameroun .. .. .	28th February, 1956
Canada .. .. .	1st January, 1933
Chile .. .. .	24th August, 1933
China .. .. .	19th November, 1935
Congo (Brazzaville) .. .. .	28th February, 1956
Costa Rica .. .. .	1st October, 1953

SECOND SCHEDULE—*continued*

<i>Government</i>	<i>Effective Date</i>
Cuba .. .. .	9th March, 1933
Czechoslovakia .. .. .	18th September, 1955
Dahomey .. .. .	28th February, 1956
Denmark .. .. .	1st January, 1933
Dominican Republic .. .. .	28th January, 1948
Ecuador .. .. .	28th May, 1950
Federation of Malaya .. .. .	10th April, 1954
Finland .. .. .	1st January, 1933
France .. .. .	1st January, 1933
Comoro Archipelago .. .. .	} 28th February, 1956
French Polynesia .. .. .	
French Somaliland .. .. .	
French Southern and Antarctic Territories .. .. .	
New Caledonia and Dependencies .. .. .	
St. Pierre and Miquelon .. .. .	
Wallis and Futuna Islands .. .. .	
Germany .. .. .	6th December, 1933
Ghana .. .. .	22nd February, 1958
Greece .. .. .	4th March, 1935
Haiti .. .. .	2nd March, 1961
Honduras .. .. .	10th September, 1948
Hungary .. .. .	16th April, 1933
Iceland .. .. .	26th February, 1933
India .. .. .	1st January, 1935
Indonesia .. .. .	27th April, 1933
Irish Republic .. .. .	8th May, 1934
Israel .. .. .	15th October, 1949
Italy .. .. .	1st January, 1933
Ivory Coast .. .. .	28th February, 1956
Japan .. .. .	11th September, 1935
Korea, Republic of .. .. .	11th September, 1954
Kuwait .. .. .	12th April, 1959
Liberia .. .. .	25th June, 1949
Malagasy Republic .. .. .	28th February, 1956

SECOND SCHEDULE—continued

B 243

<i>Government</i>	<i>Effective Date</i>
Mauritania .. .. .	28th February, 1956
Mexico .. .. .	6th September, 1934
Netherlands .. .. .	1st January, 1933
Curacao .. .. .	} 27th April, 1933
Netherlands New Guinea .. .. .	
New Zealand .. .. .	1st January, 1933
Nicaragua .. .. .	19th May, 1954
Niger .. .. .	28th February, 1956
Norway .. .. .	1st January, 1933
Pakistan .. .. .	1st January, 1935
Panama .. .. .	13th October, 1936
Peru .. .. .	30th June, 1933
Philippine Republic .. .. .	30th December, 1949
Poland .. .. .	6th December, 1933
Portugal .. .. .	1st January, 1933
Roumania .. .. .	1st April, 1933
South Africa .. .. .	24th <sup>r</sup> May, 1947
Spain .. .. .	1st January, 1933
Sweden .. .. .	1st January, 1933
Switzerland .. .. .	19th August, 1954
Thailand .. .. .	11th October, 1933
Turkey .. .. .	20th <sup>r</sup> August, 1955
Union of Soviet Socialist Republics .. .. .	1st January, 1933
United Arab Republic .. .. .	24th <sup>r</sup> October, 1936
United Kingdom .. .. .	1st January, 1933
Hong Kong .. .. .	1st September, 1938
United States of America .. .. .	1st January, 1933
Uruguay .. .. .	8th May, 1939

SECOND SCHEDULE—*continued*

<i>Government</i>	<i>Effective Date</i>
Venezuela .. .. .	30th March, 1955
Viet Nam .. .. .	15th January, 1939
Yugoslavia .. .. .	26th March, 1934

MADE at Lagos this 2nd day of July, 1964.

R. A. NJOKU,  
*Minister of Transport*

## EXPLANATORY NOTE

This order recognises the Load Line Certificates of all the other countries which are parties to the International Convention Respecting Load Lines 1930.

**Open General Import Licence (Hong Kong) No. 1 of 1963  
(Amendment) 1964***Commencement : 9th April, 1964*

In exercise of the powers conferred by section 4 of the Imports Prohibition Order, 1959, the Import Licensing Authority has amended the Schedule to the Open General Import Licence (Hong Kong) No. 1 of 1963 by the addition of the following items—

	<i>Import List No.</i>
	<i>Group      Item</i>
" 9. Tin ore .. .. .	283      60
10. Zirconium .. .. .	689      50
11. Slag resulting from the processing of Tin ..	698      90
12. Blanket (cotton) .. .. .	656      62
13. Enamelware (household) .. .. .	697      24
14. Meat, fresh, chilled or frozen .. .. .	011      00
15. Bacon and ham .. .. .	012      10
16. Other meat, dried, salted or smoked, not canned .. .. .	012      90
17. Corned Beef .. .. .	013      01
18. Other meat canned and meat preparation canned and not canned .. .. .	013      09
19. Butter .. .. .	023      00
20. Grapefruit, Fresh .. .. .	051      90
21. Grapefruit, Juice .. .. .	053      50
22. Lemons .. .. .	063      50"

J. B. ELUMEZE,  
*Import Licensing Authority,*  
*Federal Ministry of Commerce and Industry*

Lagos, 20th June, 1964.

## EXPLANATORY NOTE

The effect of this amendment is that specific import licence is now required for the importation into Nigeria from Hong Kong of any of the goods listed in the above Legal Notice.

L.N. 72 of 1964

**CUSTOMS AND EXCISE MANAGEMENT ACT, 1958**  
(1958, No. 55)

**Open General Import Licence (Netherlands) No. 2 of 1964**  
**(Amendment) 1964**

*Commencement : 9th April, 1964*

In exercise of the powers conferred by section 4 of the Imports Prohibition Order, 1959, the Import Licensing Authority has amended the Schedule to the Open General Import Licence (Netherlands) No. 2 of 1964 by the addition of the following items—

			<i>Import List No.</i>	
			<i>Group</i>	<i>Item</i>
"16. Meat, fresh, chilled or frozen	.. ..	011	011	00
17. Bacon and ham	.. ..	012	012	10
18. Other meat, dried, salted or smoked not canned	.. ..	012	012	90
19. Corned Beef	.. ..	013	013	01
20. Other meat canned and meat preparation canned and not canned	.. ..	013	013	09"
and deletion of item—				
"10. Sugar (beat and cane refined)	.. ..	061	061	020"

J. B. ELUMEZE,

*Import Licensing Authority,*

*Federal Ministry of Commerce and Industry*

Lagos, 20th June, 1964.

EXPLANATORY NOTE

The effect of this amendment is that specific import licence is now required for the importation into Nigeria from Netherlands of any of the goods listed in the above Legal Notice.

L.N. 73 of 1964

**CUSTOMS AND EXCISE MANAGEMENT ACT, 1958**  
(1958, No. 55)

**Open General Import Licence (Japan) No. 3 of 1959**  
**(Amendment), 1964**

*Commencement : 9th April, 1964*

L.N. 238 of 1959.

In exercise of the powers conferred by section 4 of the Imports Prohibition Order, 1959, the Import Licensing Authority has amended the Schedule to the Open General Import Licence (Japan) No. 3 of 1959 by the addition of the following items—

			<i>Import List No.</i>	
			<i>Group</i>	<i>Item</i>
"10. Tin ore	.. ..	283	283	60
11. Zirconium	.. ..	689	689	50
12. Slag resulting from the processing of Tin	.. ..	698	698	90
13. Blanket (cotton)	.. ..	656	656	62
14. Enamelware (household)	.. ..	697	697	24
15. Meat, fresh, chilled or frozen	.. ..	011	011	00
16. Bacon and ham	.. ..	012	012	10
17. Other meat, dried, salted or smoked not canned	.. ..	012	012	90

18. Corned Beef .. .. .	Import List No.	
19. Other meat canned and canned and not canned	Group	Item
20. Butter .. .. .	013	01
21. Grapefruit, fresh .. .. .	013	09
22. Grapefruit, juice .. .. .	023	00
23. Lemons .. .. .	051	90
	051	50
	053	50"

Lagos, 20th June, 1964.

J. B. ELUMEZE,  
Import Licensing Authority,  
Federal Ministry of Commerce and Industry

## EXPLANATORY NOTE

The effect of this amendment is that specific import licence is now required for the importation into Nigeria from Japan of any of the goods listed in the above Legal Notice.

CS411

L.N. 74 of 1964

CUSTOMS AND EXCISE MANAGEMENT ACT, 1958  
(1958, No. 55)

Open General Import Licence (Dollar Area) No. 4 of 1959  
(Amendment) 1964

Commencement : 9th April, 1964

In exercise of the powers conferred by section 4 of the Imports Prohibition Order, 1959, the Import Licensing Authority has amended the Schedule to the Open General Import Licence (Dollar Area) No. 4 of 1959 by the addition of the following items—

L.N. 239 of 1959.

	Import List No.	
"22. Tin ore .. .. .	Group	Item
23. Zirconium .. .. .	283	60
24. Slag resulting from processing of Tin .. .. .	689	50
25. Blanket (cotton) .. .. .	698	90
26. Enamelware (household) .. .. .	656	62
27. Meat, fresh, chilled or frozen .. .. .	697	24
28. Bacon and ham .. .. .	011	00
29. Other meat, dried, salted or smoked, not canned .. .. .	012	10
30. Corned Beef .. .. .	012	90
31. Other meat canned and canned and not canned	013	01
32. Butter .. .. .	013	09
33. Grapefruit, fresh .. .. .	023	00
34. Grapefruit, juice .. .. .	051	90
35. Lemons .. .. .	053	50
	053	50"

J. B. ELUMEZE,  
Import Licensing Authority,  
Federal Ministry of Commerce and Industry

Lagos, 20th June, 1964.

## EXPLANATORY NOTE

The effect of this amendment is that specific import licence is now required for the importation into Nigeria from Dollar Area of any of the goods listed in the above Legal Notice.

L.N. 75 of 1964

PERSONAL INCOME TAX (LAGOS) ACT, 1961  
(1961, No. 23)

**Personal Income Tax (Lagos) (Income Rate) (Amendment)  
Regulations, 1964**

In exercise of the powers conferred by subsection (5) of section twelve of the Personal Income Tax (Lagos) Act, 1961, and of all other powers enabling me in that behalf, I, with the approval of the Council of Ministers, hereby make the following regulations :—

Citation,  
Commence-  
ment and  
application.

1.—(1) These Regulations may be cited as the Personal Income Tax (Lagos) (Income Rate) (Amendment) Regulations, 1964, and shall come into effect on the 1st day of April, 1964.

(2) These Regulations shall apply to Lagos.

Amendment  
of L.N. 153  
of 1961.

2. The Personal Income Tax (Lagos) (Income Rate) Regulations, 1961, is hereby amended :—

(a) by the addition, after Regulation 8, of the following new Regulations :—

“(8A) Where an employer has deducted income rate from the wages, salary or other emoluments of his employees under or in accordance with the provisions of Regulations 4 and 5, the employer shall within thirty days of making such deductions prepare and deliver to the Board a return in the form and manner set out in the Schedule, giving the names and residential addresses of those employees and stating in each case the amount of the income rate so deducted for the year specified on the return :

Provided that a separate return shall be made in respect of deductions for each year of assessment.

(8B) Without prejudice to the provision of subsection (1) of section fifty-four of the Act, any employer who without reasonable excuse makes an incorrect return by omitting or understating the amount of income rate which he has deducted from the wages, salary or other emoluments of his employees or makes an incorrect return in any other material respect shall be guilty of an offence” ;

(b) by the deletion of Regulation 9 and the substitution therefor of the following :—

“(9) Subject to the provision of Regulation 8B any employer or any person who fails to comply with any of the requirements of these Regulations shall be guilty of an offence.”

(c) by the addition after Regulation 9 of the following Schedule—

"SCHEDULE  
*Personal Income Tax (Lagos) Act, 1961*  
 PARTICULARS OF INCOME RATE DEDUCTION  
 YEAR OF ASSESSMENT 19.....\*

(Reg. 8A)

No.	Name of Employee	Residential Address of Employee	Estimated Annual Income of Employee During the Current Year	Amount of Income Rate Deducted	Income Rate Receipt Number	Date on which Deduction made
1.						
2.						
3.						
4.						
5.						
6.						
7.						
8.						
9.						
10.						

Total Deduction in respect of which the return is made £.....

**DECLARATION**

I hereby declare that to the best of my knowledge and belief the above return forwarded to you contains the name and residential address of every employee under me in respect of whom a return under Regulation 8A of the Personal Income Tax (Lagos) (Income Rate) Regulations, 1961, is required together with the amount of income rate deducted from the salary, wages, or other emoluments of each such employee.

GIVEN under my hand this ..... day of ..... 196.....

Signed.....

Status.....

Name of Employer.....

Address.....

\*Insert the year of assessment to which the income rate deduction relates."

MADE at Lagos this 23rd day of June, 1964.

F. S. OKOTIE-EBOH,  
*Federal Minister of Finance*

## EXPLANATORY NOTE

The purpose of these Regulations is to provide for an employer to prepare and deliver to the Board a return, in the prescribed form, giving the names and residential addresses of his employees from whose wages, salary or other emoluments, income rate has been deducted and stating in each case the amount of the income rate so deducted. An employer who fails to prepare and deliver such a return commits an offence and is liable to a penalty.

HQS. 5076/Vol. 2

L.N. 76 of 1964

THE SEA FISHERIES (LAGOS) ACT 1961  
(1961 No. 30)

**The Sea Fisheries (Licensing) Regulations 1964**

*Commencement : 2nd July, 1964*

In exercise of the powers conferred by section 14 of the Sea Fisheries (Lagos) Act 1961 and of all other powers enabling him in that behalf, the President has made the following regulations—

- Citation and application. 1. These Regulations may be cited as the Sea Fisheries (Licensing) Regulations 1964, and shall apply to the Federal Territory of Lagos only.
- Licensing officers. 2. The Director of Fisheries is hereby appointed licensing officer for the purpose of the Act, and any receipt for fees or any licence may be given or issued by him or in his name by any person authorised by him.
- Fees and Licence. 3.—(1) Subject to the provisions of these Regulations, there shall be paid to the Licensing Officer, licence fees in accordance with the provisions of subsection (3) of section 5 of the Act in respect of motor fishing boats at the respective rates prescribed in the First Schedule.
- (2) The licence to be issued under these Regulations shall be in the form prescribed in the Second Schedule.
- Exemption. 4. Nothing in these Regulations shall apply to any fishing canoe, whether or not fitted with engines.

FIRST SCHEDULE

*Regulation 3*

<i>Gross Tonnage of Fishing Vessel</i>	<i>Annual Licence Fees</i>
1,000 tons and above .. .. .	£200
200 tons—1,000 tons .. .. .	£100
20 tons—200 tons .. .. .	£50
Under 20 tons .. .. .	£20

SECOND SCHEDULE

Regulation 3

Serial Number :

The motor fishing boat known as .....  
 registered number ..... and owned by .....  
 of ..... is hereby licensed to be  
 operated or navigated within the territorial waters of the Federal territory  
 of Lagos from the ..... day of .....  
 19..... to the ..... day of ..... 19.....  
 both dates inclusive.

2. This licence is issued subject to the following conditions :

.....  
 .....  
 .....

Issued at ..... this ..... day of ..... 19.....

Fee paid £ : : d

Licensing Officer

DATED at Lagos this 26th day of June, 1964.

I. A. WEMAMBU,  
 Acting Deputy Secretary to the  
 Council of Ministers

EXPLANATORY NOTE

These regulations provide for the fees payable for and the form of the  
 licence to be issued in respect of any motor fishing boat to be operated or  
 navigated within the territorial waters of the Federal Territory of Lagos.

L.N. 77 of 1964

CENTRAL BANK OF NIGERIA ACT (CHAPTER 30)

Central Bank of Nigeria (Amendment) Bye-Laws, 1964

Commencement : 29th May, 1964

In exercise of the powers conferred by section 48 of the Central Bank of  
 Nigeria Act, the Board of Directors of the Central Bank of Nigeria, with the  
 approval of the Minister of Finance of the Federation, hereby makes the  
 following bye-laws—

1. These bye-laws may be cited as the Central Bank of Nigeria (Amend- Short title.  
 ment) Bye-Laws, 1964.

Amendment  
of bye-law  
14. (LN 96  
of 1959).

2. For bye-law 14 of the Central Bank of Nigeria Bye-Laws, 1959, there shall be substituted the following—

“Prohibition  
from  
employment  
on other  
duties.

14. (a) “No official or other employee of the Bank shall occupy any other office or employment whether remunerated or not except with the approval of the Board embodied in a resolution and only in the following capacities, that is to say—

(i) as member of any economic research institution or of any commission established by the Federal Government to enquire into any matter affecting currency or banking in Nigeria or into such other subject as may be relative to the functions of the Bank ;

(ii) as director or member of the Board, by whatever name called, of any international bank, international monetary authority or economic institution to which the Federal Government shall have adhered or given support or approval ;

(iii) as director or alternate director of any corporation in Nigeria in which the Bank may participate under subsection (1) of section 29 of the Central Bank of Nigeria Act, as amended by the Central Bank of Nigeria (Amendment) Act, 1962.

(b) Any remuneration to which any official or other employee of the Bank is entitled in respect of any appointment made by virtue of the provisions of this bye-law shall be paid direct to the Bank.

(c) This bye-law shall not prevent the Bank from employing, at the Board’s discretion and subject to such terms and conditions as shall be laid down by the Board, part-time advisers for particular purposes and for specific periods of time”.

MADE at a meeting of the Board held on the 29th day of May, 1964 and sealed on the 29th day of May, 1964 in the presence of :—

A. N. ABAI,  
*Deputy Governor*

CHUBA IKPEAZU,  
*Director*

E. A. IYANDA,  
*Director*

F. A. IJEWERE,  
*Secretary*

APPROVED this 18th day of June, 1964.

UNIVERSITY COLLEGE HOSPITAL ACT  
(CHAPTER 205)

University College Hospital (Hospital Fees) Regulations, 1964  
Commencement : 1st August, 1964

In exercise of the powers conferred by Section 15 of the University College Hospital Act, and of all other powers enabling it in that behalf, the University College Hospital Board of Management, with the approval of the Federal Minister of Health, has made the following Regulations—

1. These Regulations may be cited as the University College Hospital (Hospital Fees) Regulations, 1964, and shall apply throughout the Federation.
2. The fees, charges and exemptions set out in the Schedules hereto shall apply to all persons attending at the University College Hospital as patients.
3. The University College Hospital (Hospital Fees) Regulations, 1961, as amended are hereby revoked.

Citation and application.

Hospital fees, charges and Exemptions.

Revocation of L.N. 112 of 1961, L.N. 12 of 1963.

FIRST SCHEDULE

PART I—IN-PATIENTS

A. *Exemptions from all Charges.*—No charges shall be levied for accommodation, maintenance or medical or nursing attention on the following :—

- (a) Members of the staff (both established and unestablished) employed in the University College Hospital, and their wives and children.
- (b) Persons certified as paupers.

(c) Persons receiving treatment or advice for pulmonary tuberculosis and other notifiable infectious disease, or incurable malignant disease.

(d) Persons who, on the certification of the Doctor in charge of the case, are admitted in hospital solely for the purposes of teaching and/or research.

B.1. *Charges for Maintenance and Accommodation only.*—Charges for maintenance and accommodation only shall be levied on the persons listed below :—

(a) Members of the Medical, Dental and Nursing professions and hospital auxiliaries and their wives and children.

(b) All other members of the Medical Department of the Governments of the Federation.

(c) A member of the Board of Management of University College Hospital, his wife and children.

(d) All children under the age of 16 years (with the exception of charges made for spectacles and dentures).

(e) The servants of officers holding senior appointments in the University College Hospital.

(f) The holder of a post on the permanent establishment of the University of Ibadan.

Charges for accommodation and maintenance of persons referred to above shall be at the following daily rates :—

	s	d
Patients—(i) whose incomes exceed £1,500 p.a. .. ..	20	0
(ii) whose incomes exceed £1,000 p.a. but do not exceed £1,500 p.a. .. ..	15	0
(iii) whose incomes exceed £750 p.a. but do not exceed £1,000 p.a. .. ..	10	0
(iv) whose incomes exceed £500 p.a. but do not exceed £750 p.a. .. ..	7	6
(v) whose incomes exceed £300 p.a. but do not exceed £500 p.a. .. ..	5	0
(vi) whose incomes are less than £300 p.a. .. ..	2	0

Provided that (i) children under sixteen years of age, school children and others undergoing full-time education, shall be charged at half the rates applicable to their parents as listed above.

B.II. *Charges for Treatment, Accommodation and Maintenance*—Inclusive charges for medical and nursing attention, accommodation and maintenance, shall be levied on all other persons at the following daily rates :—

Patients—(i) whose incomes exceed £1,500 p.a. .. ..	40	0
(ii) whose incomes exceed £1,000 p.a. but do not exceed £1,500 p.a. .. ..	30	0
(iii) whose incomes exceed £750 p.a. but do not exceed £1,000 p.a. .. ..	20	0
(iv) whose incomes exceed £500 p.a. but do not exceed £750 p.a. .. ..	15	0
(v) whose incomes exceed £300 p.a. but do not exceed £500 p.a. .. ..	10	0
(vi) whose incomes are less than £300 p.a. .. ..	4	0

B.III. *Amenity Beds*—Inclusive charges for medical and nursing attention, accommodation and maintenance shall be levied on all persons admitted to Private Wards at their own request (and irrespective of whether they are included in any of the categories in Sections A and B above) at the rate of £3 per day.

B.IV. *Charges for Surgical and Maternity Cases*—The following additional charges shall be levied on in-patients whether or not occupying an amenity bed, but not on in-patients under Sections A or B.(I.) (a) and (d) of Part I of these Regulations :—

(i) For each maternity patient delivered in hospital :		
(a) whose incomes exceed £1,500 p.a. .. ..	£25	
(b) whose incomes exceed £1,000 p.a. but do not exceed £1,500 p.a. .. ..	£15	
(c) whose incomes exceed £750 p.a. but do not exceed £1,000 p.a. .. ..	£10	
(d) whose incomes exceed £500 p.a. but do not exceed £750 p.a. .. ..	£6	
(e) whose incomes exceed £300 p.a. but do not exceed £500 p.a. .. ..	£4	
(f) whose incomes are less than £300 per annum .. ..	£2	

(ii) For each patient operated on in hospital (excluding biopsies) but including operations for the implantation of radium or radon seeds:—

	Major Operations			Other Operations		
	£	s	d	£	s	d
(a) whose incomes exceed £1,500 per annum	25	0	0	12	10	0
(b) whose incomes exceed £1,000 per annum but do not exceed £1,500 per annum ..	15	0	0	7	10	0
(c) whose incomes exceed £750 per annum but do not exceed £1,000 per annum ..	10	0	0	5	0	0
(d) whose incomes exceed £500 per annum but do not exceed £750 per annum ..	6	0	0	4	0	0
(e) whose incomes exceed £300 per annum but do not exceed £500 per annum ..	4	0	0	3	0	0
(f) whose incomes are less than £300 per annum .. .. .	2	0	0	2	0	0

For the purpose of this regulation "Major" and "Other" operations are the operations respectively so described in the second Schedule to these regulations and any other kind of operation which the House Governor may from time to time classify as falling under one of these headings.

**B.V. Charges for Patients from Outside Nigeria.**—Inclusive charges for medical and Nursing attention, accommodation and maintenance shall be levied on all persons (not being citizens of, or employed in, the Federal Republic of Nigeria) admitted into hospital irrespective of whether they are included in Section A (b) and (d) above. The rate of Charge shall be the average daily cost per in-patient.

**B.VI. Charges for Special Appliances.**—Charges for all appliances including artificial limbs supplied to any patient by the hospital shall be at cost price.

**B.VII. Charges for Non-Standard Diet.**—An additional charge of 10s per day shall be levied on all in-patients who elect to have wholly or in part a non-standard diet. This additional charge shall be made regardless of the income of patients and whether or not occupying an amenity bed and irrespective of whether they are included in any of the Categories in Section A or B above.

## PART II—OUT-PATIENTS

**A. Exemptions.**—No charges for out-patients treatment of any kind will be levied on the persons listed in Sections A and B.I. of part I of these regulations.

**B. Charges will be levied on all other persons as follows:—**

(i) **General Out-Patients.**—On first attendance a fee of 5s will be charged to cover all treatment for one week from the date of payment. A further charge of 5s will be made for each subsequent period of one week or part thereof.

(ii) *Casualty Department.*—Medical Attendance :

- (a) Between 7 a.m. and 7 p.m. 5s on first attendance.
- (b) Between 7 p.m. and 7 a.m. 10s on first attendance provided that the Medical Officer on duty shall have power to authorise payment of the normal charge of 5s in cases of trauma and medical emergencies.
- (c) For non emergency cases on Sundays and Public Holidays—10s on first attendance.

The payment of the prescribed fee will be valid for treatment for a period of one week or part thereof in either the Casualty or the General Out-Patient Department.

(iii) *Patients referred to Consultant Clinics* (including those referred direct from outside hospitals or medical practitioners)

With incomes under £500 per annum 5s on first attendance	} This Charge to cover attendance at Consultant Clinic for the first month
With incomes of £500-750 per annum £1 on first attendance	
With incomes of £751-1,000 per annum £2 on first attendance	
With incomes of £1,001-1,500 per annum £3 on first attendance	
With incomes of £1,501-2,000 per annum £4 on first attendance	
With incomes of £2,001-3,500 per annum £5 on first attendance	
With incomes of over £3,500 per annum £10 on first attendance	

Patients continuing to attend Consultant Clinics after a month to pay half the above charges for each attendance except those with incomes of under £500 who will pay the same as General Out-Patients, *i.e.*, 5s for each attendance.

*Note.*—A patient attending the General Out-Patient Department and referred to a Consultant Clinic within the same week will not be expected to pay an additional 5s in the Consultant Clinic if his income is under £500 per annum.

(iv) The payments stated in paragraphs (i) and (ii) may be deferred at the discretion of the Doctor or Sister in charge at the time of attendance of a seriously ill patient. In such a case, the charge becomes payable at the time of the next visit.

(v) *Ante-Natal Clinic.*—A fee of 10s will be payable at the time of booking to cover all attendances during pregnancy and attendance at the post-natal clinic until discharged. The fee charged will not include maintenance or delivery in hospital, for which the charges laid down in Section B of Part I of these Regulations will be applicable.

(vi) The following additional charges shall be levied on all Out-Patients (irrespective of the attendance fees they may have paid under Sections B (i)-(iii) above) for services outlined at (a)-(d) below :—

(a) <i>Radiological Services</i>		
(i) For each X-ray .. .. .	£	s d
(ii) For each Special examination .. .. .	0	5 0
(iii) X-ray examination and report for outside agencies .. .. .	0	10 0
(b) <i>Physiotherapy Services</i>		
(i) For Physiotherapy treatment for one week or part thereof .. .. .	0	5 0
provided that a complete course of treatment shall not exceed .. .. .	5	0 0
(c) <i>Pharmaceutical Services</i>		
(i) For each prescription dispensed in the hospital .. .. .	0	1 0
(ii) For each course of treatment by injection administered in hospital .. .. .	0	2 0
(d) <i>Pathological Services</i>		
(i) Pathological examination and report for outside agencies :		
For each single or simple examination involving less than 1 hour bench work .. .. .	0	5 0
(ii) For multiple or more complicated examinations .. .. .	0	10 0

PART III—GENERAL

*General*

1. Fees payable by an In-Patient shall be assessed on the basis of the income of such patient ; a married woman shall be charged at the rate applicable to her husband or according to her own income, whichever may be higher.

2. All sums due are payable on discharge from the Hospital to the Hospital Authority, but an In-Patient may be asked to deposit at intervals an amount as may be determined by the Hospital Authority towards the cost of his final hospital bill. Where such monies are not so paid, the House Governor may sue for and recover the same with full cost of suit.

3. In any such proceedings a statement signed by the House Governor setting forth the amount claimed from the defendant shall be admitted in evidence without proof of the signature, and shall be prima facie evidence of the amount due.

4. All sums received by the Hospital Authority shall be paid into the account of the Hospital and shown in the annual Financial Accounts of the Hospital.

5. Any person who considers that his income has been assessed at an excessive figure shall have the right to appeal to the House Governor against such assessment.

6. If any person for the purpose of evading the payment of any charge under these Regulations or of reducing the amount of any such charge :—

(a) knowingly makes any false statement and false representation ; or

(b) produces or furnishes or causes or knowingly allows to be produced or furnished, any document or information which he knows to be false in a material particular ;

he shall be guilty of an offence and on conviction to a fine of Five pounds in addition to paying for the medicine, surgical appliance, attendance or treatment at the highest rate prescribed by or under these Regulations.

7. Notwithstanding anything contained in Parts I, II and III of these Regulations, the House Governor may waive or reduce the fees chargeable if he is satisfied that in all the circumstances of the case the financial position of the person warrants such a waiver or reduction.

8. A senior appointment, for the purpose of these Regulations, is one carrying an initial basic salary of £594 per annum or more.

9. A pauper certificate must be signed by one of the following :—

(a) A Minister of Religion or Imam

(b) A registered Medical Practitioner

(c) The Chairman of the Local Government Council in the area in which the patient resides

(d) Magistrate or Alkali

If a pauper cannot produce such a certificate, the Almoner shall have authority to issue the certificate, if she is satisfied that the patient is in fact a pauper.

## SECOND SCHEDULE

### SURGICAL OPERATIONS

### MAJOR

Abscess of brain  
 Acute appendicitis  
 Adenoma of thyroid  
 Amputation of hip  
 Amputation of limbs, except fingers and toes (other) and thigh shoulder and hip (major)  
 Amputation of penis (total)  
 Amputation of shoulder  
 Amputation through thigh  
 Any operation involving intestinal suture  
 Appendicitis (non-acute)  
 Biliary fistula

Carcinoma of the colon  
 Cholecystectomy  
 Cholecystenterostomy  
 Closure of faecal fistula or artificial anus  
 Complete prolapse of rectum involving laparotomy, colostomy or intestinal  
 anastomosis  
 Complicated fistula  
 Craniotomy  
 Cystectomy  
 Depressed fracture  
 Diverticulitis  
 Double inguinal hernia  
 Drainage of bile ducts  
 Drainage of gall bladder  
 Empyema  
 Enterotomy, colotomy, colostomy  
 Epithelioma of the anus  
 Epithelioma of lip with excision of glands  
 Epithelioma of the tongue with radical operation upon the glands  
 Excision of cysts or tuberculous glands of neck (deep to deep fascia)  
 Excision of larger joints  
 Excision of rectum  
 Gastrectomy  
 Gastro-enterostomy  
 Gastrostomy  
 Gastrotomy  
 Hernia (strangulated or irreducible)  
 Haemorrhoidectomy  
 Hydatid of lung or liver  
 Implantation of radium or radon seeds in the cranium, chest, abdomen  
 or bladder  
 Intestinal obstruction (including Intussusception)  
 Laminectomy  
 Hernia—inguinal, femoral umbilical or ventral (simple)  
 Imperforate anus  
 Litholapaxy  
 Meningeal haemorrhage  
 Nephrectomy  
 Perforated ulcer of the alimentary tract  
 Peritonitis (tuberculous, pneumococcal)  
 Prefrontal leucotomy  
 Prostatectomy  
 Pyelo-or nephro-lithotomy  
 Radical removal of breast

SECOND SCHEDULE—*continued*

Rammstedt's operation  
 Radical operation for anal fissure  
 Removal of stone from ureter  
 Rupture of bladder  
 Rupture of urethra  
 Splenectomy  
 Sacro-coccygeal dermoid sinus  
 Subphrenic abscess requiring trans-thoracic or trans-peritoneal access  
 Suprapubic cystostomy  
 Sympathectomy  
 Thyroidectomy  
 Transplantation of ureters  
 Tumour of the brain

## OTHER

Abscess of prostate  
 Abscess  
 Amputation of fingers or toes  
 Amputation of penis (Partial)  
 Any condition treated by surgical diathermy under general anaesthesia,  
 other than mouth, or tongue, or bladder  
 Blood transfusion (grouping and expenses of doner extra)  
 Castration  
 Cystoscopy  
 Dilaton of anus for fissure  
 Dilaton of rectal stricture  
 Dilaton of urethra  
 Diathermy to growths of bladder  
 Division of fibrous anus  
 Examination under anaesthetic  
 Fistula-in-ano  
 Hydrocele (injection)

## OTHER

Hydrocele (radical)  
 Implantation of radium or rondon seeds for treatment of skin tumour  
 Implantation of radium or rondon seeds except where included under  
 "Major"  
 Induction of pneumothorax  
 Injection of Gasserian ganglia  
 Injection for pruritus ani  
 Prolapse of rectum  
 Rectal polypi  
 Simple removal of whole breast  
 Ischiorectal abscess  
 Lupus  
 Pyelography (not including services of radiologist)  
 Removal of anal warts and anal papillae  
 Removal of needles from hand or foot or elsewhere  
 Rodent ulcer not involving bone or eye  
 Sebaceous cysts  
 Tuberculous caseous glands of neck (curetting)  
 Varicocele

*Vulvo-Vaginal :*

MAJOR

- Anterior and posterior colporrhaphy with amputation of the cervix (Manchester operation)
- Anterior and posterior colporrhaphy with vaginal hysterectomy (Manchester operation)
- Any vaginal operation when combined with coeliotomy, viz., colpo-perineoplasty with ventrofixation
- Radical excision of vulva and glands
- Repair of vaginal fistulae
- Vaginal hysterectomy
- Relief of atresia vaginae

*Uterus and Adnexa*

- Cyst of the broad ligament
- Hysterectomy
- Myomectomy
- Salpingectomy (acute inflammation, complicated pyo- or hydro-salpinx, extra-uterine gestation)
- Ovariectomy
- Salpingectomy or Salpingostomy

OTHER

*Vulvo-Vaginal*

- Anterior and posterior colporrhaphy
- Colporrhaphy and/or perineorrhaphy
- Cauterisation
- Cysts or simple tumours of the vulva and vagina
- Removal of caruncle
- Urethral prolapse
- Colpotomy

*Uterus and Adnexa :*

- Dilatation with intra-urine operations
- Evacuation of retained products

*Cervix :*

- Dilatation
- Insufflation
- Removal of polypi

NOTE :—EVA, Biopsy of Cervix, Diagnostic Curettage are excluded, as they count as *Biopsies* and are therefore free.

EAR, NOSE AND THROAT OPERATIONS

MAJOR

- Extensive operative treatment of malignant disease
- Open, *i.e.*, external operation on the larynx and pharynx (exclusive of laryngotomy)
- Open operations on the nasal accessory sinuses
- Operations on the temporal bone exclusive of simple mastoidectomy
- Simple tracheotomy
- Mastoidectomy
- Reduction of long standing facial bones
- Operative treatment of malignant disease involving skin of face only

SECOND SCHEDULE—*continued*

## OTHER

Diagnostic peroral endoscopy  
 Opening of quinsies  
 Mastoidectomy—Drainage of mastoid abscess  
 Myringotomy  
 Reduction of fractured nose  
 Operative peroral endoscopy (*i.e.* bronchoscopy, oesophagoscopy and laryngoscopy)  
 Intra-nasal operations  
 Removal of tonsils or adenoids  
 Simple removal of nasal polypi

## OPHTHALMIC OPERATIONS

## MAJOR

Corneal grafting  
 Conical cornea  
 Corneal abscision or tattooing  
 Corneal wound  
 Detachment of retina  
 Epicanthus  
 Exenteration of lachrymal sac, all methods  
 Exenteration of orbit  
 Excision of rodent ulcer  
 Excision of evisceration of eyeball  
 Exploration of orbit  
 Extraction of senile cataract  
 Claucoma, acute or chronic  
 Iridectomy  
 Kronlein's operation  
 Operation for dislocated lens  
 Ptosis  
 Reconstruction of eyelids  
 Needling capsule after senile cataract  
 Needling juvenile cataract  
 Orbital abscess  
 Randon applications for neoplasm  
 Removal of intraocular foreign body  
 Removal of intraorbital tumours  
 Strabismus

## OTHER

Canaliculus and lachrymal duct exploration  
 Cauterisation of corneal ulcer  
 Chalazion  
 Ectropion  
 Entropion  
 Excision of pterygium  
 Lachrymal abscess  
 Paracentesis  
 Trichiasis  
 Peritomy  
 Removal of superficial dermoid  
 Removal of foreign body embedded in cornea  
 Suturing lid wounds

MAJOR

- Amputation through thigh
- Amputation of limbs, except fingers and toes (other) and thigh shoulder and hip (major)
- Closed reduction and fixation of fractures involving joints or shafts of larger bones
- Congenital club foot
- Congenital dislocation of the hip
- Disarticulation of the hip and shoulder
- Emergency operations for acute osteomyelitis and acute suppurative arthritis
- Excision of cervical rib
- Excision of larger joints
- Internal derangement of the knee and other joints
- Laminectomy
- Open reduction of fractures
- Operative treatment of compound fractures
- Radical Operations for bone tumours
- Reconstructive operations on bones and joints :—
  - arthrodesis
  - arthroplasty
  - bone grafts
- Repair of intricate tendon injuries
- Secondary nerve sutures
- Severe congenital and acquired deformities requiring open correction
- Spina bifida
- Tendon transplantation
- Other orthopaedic operations requiring an equivalent degree of surgical skill

OTHER

- Excision of bursae communicating with larger joints
  - Manipulation of larger joints
  - Open correction of simpler deformities :
    - Hallux valgus
    - Hallux rigidus
    - Pes cavus
    - Torticollis
- } unilateral
- Primary nerve and tendon repairs
  - Amputations of toes and fingers
  - Application of plaster-of-paris casts with or without anaesthesia
  - Hammer toe
  - Manipulation of smaller joints
  - Removal of exostoses
  - Removal of small bursae
  - Simple manipulation of tenotomy and plasters

SECOND SCHEDULE—*continued*

## PLASTIC SURGERY OPERATIONS

## MAJOR

- Re* Repair of hare-lip and/or cleft palate  
 Repair of syndactyly  
 Repair of hypospadias  
 Excision of maxilla  
 Excision of mandible  
 Osteotomy of maxilla or mandible  
 Tube pedicle repairs  
 Flap repairs  
 Major skin grafting operations  
 Skin grafting of major burns  
 Excision of burns  
 Excision of malignant lesions with plastic repair  
 Macillo-facial injuries, needing plastic repair  
 Major cosmetic work : *e.g.* on breast, nose, ears, etc.  
 Major reconstructive work following cancrum oris, leprosy infections  
 Vaginal reconstruction

## OTHER

- Scar excision  
 Excision of keloids  
 Dressings under anaesthesia  
 Dental extractions  
 Eyelet wiring  
 Z-plastics and minor flap repairs  
 Excision of sloughs  
 Excision of benign lesions with plastic repair  
 Minor skin grafts

MADE by the University College Hospital Board of Management this 22nd day of June, 1964.

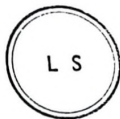

K. A. ABAYOMI,  
*Chairman*

GERARD PARKER,  
*Secretary*

## EXPLANATORY NOTE

The Regulations prescribe the fees and other Charges which are to be paid by all persons attending as patients at the University College Hospital and set out the persons who are exempted from all or part only of its provisions.

2. The Regulations replace those published as Legal Notice 112 in *Gazette* No. 66 of 14th September, 1961.

MH1188/S. 33

L.N. 79 of 1964

THE SEA FISHERIES (LAGOS) ACT, 1961  
(No. 30 OF 1961)

**Appointed Day Notice, 1964**

In exercise of the powers conferred on me by subsection (1) of section one Sea Fisheries (Lagos) Act, 1961, I hereby appoint the first day of July, 1964 as the which the above Act shall come into operation.

DATED at Lagos this 19th day of June, 1964.

WAZIRI IBRAHIM,  
*Federal Minister of Econo-  
Development*

RF6/354



L.N. 79 of 1965

EXCISE (CONTROL OF DISTILLATION) ACT 1964  
(1964, No. 22)

Manufacture of Spirits Regulations 1965

Commencement : 1st June 1965

In exercise of the powers conferred by section 3 (1) of the Excise (Control of Distillation) Act 1964, and of other powers enabling me in that behalf, I hereby make the following regulations—

A.—GENERAL

1. These regulations may be cited as the Manufacture of Spirits Regulations 1965, and shall apply throughout the Federation. Citation.
2. In these regulations unless the context otherwise requires— Definition.
  - “written notice” means a written notice in the form approved by the Board ;
  - “feints” means spirits conveyed into a feints receiver ;
  - “locked” means locked with a revenue lock or otherwise secured by an officer ;
  - “low wines” means spirits of the first extraction conveyed into a low wines receiver ;
  - “approved” means approved by the Board ;
  - “still” includes any part of a still ;
  - “wort” means any material which, by a process of fermentation, produces alcohol ;
  - “wash” means wort to which yeast has been added ;
  - “bub” means a preparation of concentrated and actively working yeast for addition to wort ;
  - “period” means the period prescribed for the purpose of taking account of feints and spirits produced ;
  - “distiller’s warehouse” means a place of security for the time being approved and licensed by the Board.

B.—APPLICATION FOR LICENCE, ENTRY AND SECURITY OF PREMISES AND VESSELS

- 3.—(1) An application for a licence to manufacture spirits shall be made in writing to the Board in the form prescribed in the First Schedule and shall include a description of the processes and of all vessels, utensils, pipes and fittings intended to be used in the manufacture of spirits, together with a drawing distinctly showing the course, construction and use of all fixed pipes to be used and of every branch thereof and cock thereon and every place, vessel or utensil with which any pipe connects. Licence to manufacture spirits.
- (2) The Board may approve such processes, vessels, utensils, pipes and fittings and may issue a licence in the form prescribed in the Second Schedule subject to the acceptance of a bond security and such other conditions as it may specify.

(3) The Board may refuse to grant a licence—

(a) in respect of premises on which from their situation in relation to other premises used by a rectifier, blender, methylator or brewer, it deems it inexpedient to allow the manufacture of spirits ;

(b) where a licence is sought for the manufacture of spirits by distillation of a fermented liquor in respect of a still which has less than four hundred gallons capacity, or subject to such conditions as it deems fit ;

(c) for any other reasons whatsoever.

4.—(1) No person shall begin to manufacture spirits until he has made entry, in accordance with the provisions of the excise laws of all rooms, plants, equipment and places in which any part of his trade is carried on or any spirits are to be kept and of all vessels, utensils, pipes, and fittings therein.

(2) Every entry shall be accompanied by—

(a) a plan in quadruplicate of each building, room or place to which the entry relates and of the situation of such building, room or place in relation to other buildings, rooms or places in the vicinity ; and

(b) specifications and particulars, in quadruplicate, of each item of plant to be used in the manufacture, preparation for sale or storage of materials or spirits.

(3) A distiller shall not, save as permitted by the Board—

(a) make entry of a room or place for more than one purpose ; or

(b) withdraw his entry whilst there remains in any place mentioned therein any still, or in any place, vessel or utensil mentioned therein any materials prepared or fit for distillation, or any spirits liable to duty.

5. Every distiller shall affix and maintain to the satisfaction of the Board in a conspicuous position outside his distillery a signboard showing the name, or if that name is different from the business name, the business name of the distiller, and a statement that he is the holder of a distiller's licence.

6.—(1) A distiller may provide in association with his distillery a place of security for the deposit of spirits manufactured at that distillery and, if that place is approved and licensed by the Board and entry is made thereof by the distiller, may deposit therein without payment of duty any spirits as manufactured. Provided that if the place of security provided under this regulation is outside the distillery premises, the Board may attach to its approval such conditions as it sees fit, and if the distiller fails to comply with any of such conditions, that place shall be deemed not to have been approved by the Board.

(2) A distiller shall not, after the approval and licensing of a distiller's warehouse provided by him, make without the previous consent of the Board, any alteration or addition thereto.

(3) The Board may specify conditions—

(a) for warehousing of spirits in a distiller's warehouse ;

(b) for securing the duty on spirits so warehoused.

(4) The Board may at any time for reasonable cause revoke or vary the terms of its approval and licensing of a distiller's warehouse.

7.—(1) A distiller shall, to the satisfaction of the Board—

(a) place and keep each vessel and utensil on his premises in a convenient situation, easy of access for official examination and account, and fixed so as to admit of the contents being accurately gauged ;

try of  
mises.

Signboard.

Distiller's  
Warehouse.

Vessels,  
pipes,  
fittings,  
etc.



(4) Before removing any sugar, molasses or other materials for the purpose mentioned in paragraph 3 of this regulation, the distiller shall give the proper officer written notice, specifying the time of the intended removal and the quantity to be so removed.

(5) At the time so specified, the distiller shall convey the specified sugar, molasses or other materials immediately from the sugar store, molasses store or other materials store to the mash tun, sugar cane crusher or other entered vessels or utensil to be immediately used there in the manufacture of spirits.

(6) The distiller shall forthwith deposit again in the sugar store, molasses store or other materials store, all sugar, molasses or other materials so removed and not so used, and shall immediately give the proper officer written advice of the quantity so deposited.

Notice to commence or re-commence brewing.

11. A distiller shall, at least six days before commencing to brew wort or, if he has discontinued brewing wort for more than a month, before recommencing to brew wort, give to the proper officer a written notice specifying the day on which he intends to begin brewing or re-commence brewing.

Period of manufacturing operation.

12.—(1) For the purpose of the charge of duty on spirits made in the distillery, a distiller shall conduct his manufacturing operations in periods which shall terminate at intervals not exceeding a month from the date of commencement of brewing or from the date of termination of the last preceding period whichever is the later.

(2) A distiller shall give to the proper officer written notice of his intention to terminate a period, with a declaration on the approved form specifying the such wort or wash shall thereupon be distilled and the stills shall be worked off and notice given to the proper officer to take account of the feints and spirits produced.

(3) A period shall be deemed to terminate when all the wort or wash specified in the distiller's declaration has been distilled and the feints and spirits produced therefrom conveyed into the respective receivers.

Notice to mash or brew.

13. A distiller shall, before he mashes any materials, or brews for making wort, give to the proper officer twenty-four hours written notice specifying the day and hour when the mashing or brewing is to be commenced.

Declaration of worts collected.

14. Immediately the collection of wort in any fermenting vessel is completed, the distiller shall deliver to the proper officer a written declaration in the approved form specifying—

(a) the number of the vessel in which the wort is contained ;

(b) the true original gravity of the wort ; and

(c) the quantity thereof as measured by the number of dry inches and tenths of one inch, that is to say, by the number of inches and tenths of one inch between the dipping plate of the vessel and the surface of the wort contained therein ;

and after the declaration has been delivered the quantity or gravity shall not be increased except as provided for in these regulations.

Addition of Yeast, etc.

15. No yeast or other matter capable of causing fermentation shall be added to wort or wash in any vessel other than a fermenting vessel except with the consent of the Board and subject to such conditions as it may impose.

16. A distiller shall, before beginning to make bub or any other composition for promoting the fermentation of wort or wash, give to the proper officer twenty-four hours written notice specifying the time when, and the vessel in which, the composition is to be made, the fermenting vessel into which it is to be put, and the quantity to be put into such vessel.

Notice to make bub, etc.

17.—(1) A distiller shall not remove any wash from a fermenting vessel unless immediately prior to such removal he has given to the proper officer a declaration in an approved form specifying—

Declaration before removing wash from fermenting vessel.

- (a) the vessel from and to which wash is to be removed ;
- (b) the day and hour of commencing removal ; and
- (c) the gravity of the wash at that time.

(2) If in any instance a distiller has removed wash to a wash charger other than for immediate distillation, he shall immediately before commencing to remove such wash for distillation, give to the proper officer a further declaration specifying the like particulars as required by this regulation.

18.—(1) A distiller shall not mix wort or wash, other than wash removed for immediate distillation, unless—

Mixing of wort, etc. Declaration after mixing.

- (a) he has previously delivered the declaration required by regulation 14 ;
- (b) the mixing takes place in a fermenting vessel or wash charger ; and
- (c) he has delivered to the proper officer written notice of his intention to mix the wort or wash specifying the vessels which will be affected.

(2) Immediately after the mixing has been completed, the distiller shall deliver to the proper officer a declaration specifying as regards each vessel affected, the dip and original gravity immediately before the operation and the dip and gravity immediately after the operation.

19.—(1) A distiller shall not dispose of wash removed from a fermenting vessel for the recovery of yeast except in such manner as may be approved by the Board.

Removal and declaration of wash removed.

(2) A distiller shall give written notice to the proper officer specifying the quantity and original gravity of the wash so removed and the vessel from which it has been removed.

20.—(1) The gravity of the wort or wash shall be ascertained by the approved saccharometer.

Ascertainment of gravity.

(2) When fermentation has commenced in any wort or wash so that the original gravity of the worts from which the wort or wash is made cannot be ascertained by the approved saccharometer, such gravity may be determined by such means as the Board may approve.

21. A distiller shall not have in his possession any wort or wash the original gravity of which, as ascertained from any sample thereof taken from a fermenting vessel or wash charger, differs by more than two degrees from the original gravity thereof as declared by him.

Difference in original gravity wort, etc.

#### D.—ASCERTAINMENT OF STRENGTH, PRODUCT AND ATTENUATION CHARGE

22.—(1) (a) The strength of spirits shall be ascertained by means of Tralles' Alcoholometer and its associated table as deposited by the Board with the Federal Government Chemist ;

Ascertainment of strength of spirits.

(b) The strength of spirits shall be taken to be the percentage by volume of pure alcohol contained in those spirits determined at a temperature of fifteen point five six degrees Centigrade or sixty degrees Fahrenheit ;

(c) Where the indicated strength at any given temperature on the Tralles' Alcoholometer falls between two consecutive numbers appearing in the table, a proportionate adjustment shall be added to the lesser of the two numbers and the amount so determined shall be deemed to be the strength of the spirits.

(2) Where the spirits contain any substance other than ethyl alcohol and water, the Board may, if it sees fit, either—

(a) cause to be removed from the spirits any such substance to the extent which it considers necessary by distillation or such other process as it may direct and may, after the addition of water to replace the quantity so removed, ascertain the strength of the spirits by means authorised by this regulation ; or

(b) treat the spirits as though they contain ethyl alcohol and water only.

Ascertain-  
ment of  
product.

23. In the event of any difference between the calculated product from materials used and the actual product, the higher figure shall be used in respect of calculation of excise duty. Duty charge shall be deemed to be payable at the time the spirit is finally collected unless the spirits are :—

(a) transferred immediately to an approved bonded warehouse ; or

(b) removed for an approved use or purpose without payment of duty ; or

(c) subjected to a denaturing process approved by the Board.

Calculation  
of attenua-  
tion charge.

24. Where spirits are manufactured by distillation of a fermented liquor, the product deemed to be manufactured from materials shall be calculated in respect of each distillation period in accordance with the following provisions of this regulation—

(a) there shall be calculated the quantity of spirits of the strength of fifty per centum by volume of pure alcohol capable of being produced from any wort and wash made at the distillery on the assumption that from every one hundred gallons of wort and wash, one gallon of spirits at the strength of fifty per centum by volume of pure alcohol will be produced for every five degrees of difference between the highest gravity of the wash before distillation, and so in proportion for any less number of gallons of wort and wash and any less number of degrees of attenuation ;

(b) the gravity of wort or wash for the purposes of paragraph (a) of this regulation shall be taken as that declared by the distiller ; provided that if either gravity is found by the proper officer before distillation and if gravity so found is, in the case of wort, higher or, in the case of wash, lower than that declared by the distiller, the gravity to be taken shall be that so found by the proper officer ;

(c) there shall be ascertained the quantity of spirits and feints computed at the strength of fifty per centum by volume of pure alcohol produced at the distillery after deducting the feints remaining at the end of the last preceding distillation period ;

(d) if the quantity calculated under paragraph (a) of this regulation exceeds the quantity ascertained under paragraph (c) of this regulation, the excise duty on spirits shall be charged and become payable immediately on that excess.

Provided that the Board may make such allowance as in its opinion is reasonable from any charge under this regulation on proof to its satisfaction that the charge arises wholly or in part on account of the removal of wort or the separation of yeast or on account of the loss or destruction of wort or wash by unavoidable accident.

25.—(1) Subject to the provisions of paragraph 2 of this regulation as to feints remaining from a previous distillation, or as may be approved in any case, a distiller shall keep all the produce of a period unmixed with any other matter and separate from all other produce until account has been taken by the proper officer.

Disposal  
of feints.

(2) Any feints produced by and remaining from a previous distillation may be mixed with the low wines or feints produced by a subsequent distillation and the process of re-distilling feints may be repeated as often as the distiller thinks fit.

26. Not less than four hours before the removal of any low wines or feints from a receiver, a distiller shall give to the proper officer written notice specifying the date and hour of intended removal, and immediately after the officer has taken account of the contents of the receiver they shall be removed forthwith into the proper charger.

Notice to  
remove  
feints.

Provided that where the distiller has secured his low wines and feints pumps to the satisfaction of the Board, he may at any time without notice, remove low wines and feints from the receiver to a charger and redistil them.

27. At the end of each period the distiller shall sign and deliver to the proper officer a return, in duplicate, in an approved form specifying—

Return of  
materials  
and spirits  
produced.

(a) the quantity of each description of material used in the making of wort or wash during the period ;

(b) the quantity of wort or wash decreased or distilled during the period ;

(c) the quantity of spirits computed at the strength of fifty per centum of pure alcohol as ascertained by Tralles' alcoholometer produced during the period ;

(d) the quantity of feints remaining at the end of the period.

28. At any time when distillation is not in progress, the distiller shall, if so required by the proper officer, draw off water from the worm tubs or refrigerators, and these vessels shall remain empty until the officer completes his examination of the spirit pipes therein.

Drawing  
off water  
from  
worm, etc.

#### E.—WAREHOUSING OF SPIRITS

29.—(1) (a) Not less than four hours before he intends to warehouse any spirits a distiller shall give a written notice to the proper officer to take account of such spirits, specifying the day and hour of intended warehousing and the vessel in which the spirits are contained ;

Warehousing  
of  
spirits.

(b) When such spirits are contained in a spirit receiver which is not also entered as a warehouse vat, the distiller shall remove them to the distiller's warehouse immediately after the account has been taken by the officer ;

(c) When such spirits are contained in a receiver which is also entered as a warehouse vat, they shall be deemed to be warehoused immediately the account has been taken by the officer ;

(d) The quantity found in the spirit receiver shall in all cases be deemed to be the quantity warehoused.

(2) All the spirits produced in a period shall be warehoused within ten days from the end of that period.

30. Save as permitted by the Board, and subject to such conditions as from time to time it sees fit to impose, a distiller shall not deposit any spirits in his distiller's warehouse other than spirits manufactured in the distillery to which the warehouse is attached.

31. A distiller's warehouse shall not be opened except during such hours as the Board shall approve and such hours may be varied at any time at the discretion of the Board.

32. With the consent of the Board and subject to such conditions it may impose, a distiller may keep receivers or vats in the distiller's warehouse or in a room on his entered premises for the storage of spirits and while such spirits are stored in such receiver or vat they shall be deemed to be in a distiller's warehouse.

33. The Board may specify—

(a) the type and description of vessels and other containers which may be used in a distiller's warehouse ;

(b) such conditions as it may consider necessary to ensure proper excise control in respect of operations in a distiller's warehouse ;

(c) conditions for, and limitations in respect of, the dilution of spirits.

34. In connection with the first racking of spirits from vat, the distiller shall comply with the following provisions—

(a) he shall before spirits are racked give notice thereof in writing to the officer in charge of the warehouse ;

(b) he shall not, except with the consent of the Board, reduce spirits with water unless the reduction takes place prior to or at the time of—

(i) their removal from the warehouse vat for immediate delivery ; or

(ii) their first racking into cask ;

(c) he shall not warehouse casks or drums whether full or on ullage, which contain less than nine gallons, provided that a vat remnant of any quantity not exceeding one hundred and fifty gallons may be temporarily warehoused in one ullage cask or drum for inclusion in a subsequent racking ;

(d) (i) he shall cause to be legibly cut, branded or painted with oil paint on the outside of each end of every cask or drum the following particulars—

(a) the name of the distiller ;

(b) the name of the distillery or place ;

(c) the mark and number of the cask or drum ;

(d) the number of gallons the cask or drum is capable of containing, and if that number is less than eighty, the quarter or quarters of a gallon of capacity above the number of entire gallons ; and

(e) the year in which it is warehoused ;

(ii) he shall cause to be consecutively numbered all the casks or drums warehoused in any one year, beginning with number one in each year ;

(iii) he shall arrange casks or drums in warehouse so that the marks thereon are at all times easily visible.

Spirits which may be deposited in a distiller's warehouse.

Hours of opening distiller's warehouse.

Vats, etc. in distiller's warehouse.

Approval, vessels, etc., and operations in distiller's warehouse.

Racking of spirits, marking of casks, drums, etc.

35. Subject to the approval of the Board, a distiller may bottle absolute alcohol in an approved compartment of his warehouse and pack the bottles into cases and may warehouse the bottles so packed in accordance with the following provisions—

(a) the minimum quantity of absolute alcohol which may be warehoused at any one time must not be less than nine bulk gallons ;

(b) absolute alcohol may be warehoused in approved vessels each containing not less than four and one half bulk gallons, or in bottles of a uniform size of a capacity not less than one reputed quart, packed in cases each containing not less than one point seven eight nor more than two liquid gallons ;

(c) cases and vessels shall, if so required by the Board, be secured and marked by the distiller in such manner as the Board may direct.

36. A distiller shall provide a stock book in the form and manner approved by the Board and shall— Stock Book.

(a) each day enter therein the particulars of all spirits manufactured and received into stock and of all spirits sent out of stock and such other particulars as the Board may require ;

(b) keep the stock book in such part of the entered premises as the Board may require, available at all times for inspection by an officer and permit an officer at any time to inspect it and make extracts therefrom ;

(c) send to the proper officer on or before the seventh day of each month a transcript in duplicate of the stock book showing all transactions entered therein during the previous month.

#### F.—DELIVERIES

37.—(1) Spirits shall not be delivered from the distillery in which they were distilled, whether from the distiller's warehouse or direct from the receivers or vats provided in accordance with regulation 32 except— Delivery of  
spirits from  
warehouse.

(a) on payment of duty for home use in accordance with the provisions of the Excise Tariff Act 1958 ; or

(b) for exportation or loading as aircraft or ships stores ; or

(c) for removal under bond for re-warehousing in an approved bonded warehouse ; or

(d) for removal for approved use in accordance with the provisions of customs and excise laws without payment of duty ;

(2) Except as permitted by the Board, all spirits delivered in accordance with the provisions of paragraph (1) of this regulation shall be accompanied by an approved removal permit and shall be subject to such limitations and conditions as may be specified in such permit.

(3) The distiller shall give written notice in the approved form to the proper officer before any spirits are delivered in accordance with this regulation and shall attach to such notice any removal permit or other document which may be required by these regulations to cover such delivery.

(4) Deliveries under this regulation shall only be made in casks, containers, or by other means approved by the Board and secured to the satisfaction of the Board.

(5) The Board may limit the hours during which deliveries may be made under this regulation.

38. Except with the permission of the Board, upon its being satisfied as to the necessity, and subject to such conditions as it may impose, a distiller shall not remove spirits from his distiller's warehouse to another distillery.

39.—(1) Except with the permission of the Board and in accordance with any conditions which it may impose, no spirits delivered in accordance with regulation 37 shall be returned to the distillery in which they were manufactured or to any other distillery.

(2) Except as provided in paragraph (1) of this regulation, a distiller shall not have on, bring to, or store in his entered distillery premises or distiller's warehouse any spirits which he has not himself distilled or on which duties of customs and excise have been paid.

(3) Spirits for home use on which excise duty has been paid or secured shall forthwith be removed from the entered distillery premises or distiller's warehouse.

40. Any person or distiller contravening or failing to comply with any of these regulations shall in respect of any particular offence against the regulations be liable to a fine of not less than one hundred pounds or more than five hundred pounds, or to imprisonment for a term of two years, or to both, and anything in respect of which such an offence is committed shall be liable to forfeiture or to disposal as the Board may direct.

41. These regulations shall apply only to the manufacture of spirits by distillation of a fermented liquor.

MADE this 31st day of May 1965.

F. S. OKOTIE-EBOH,  
Minister of Finance

Spirits not to be removed to another distillery. Spirits not to be returned to warehouse.

Offences and Penalties.

Application of regulations.

FIRST SCHEDULE  
CUSTOMS AND EXCISE (NIGERIA)  
APPLICATION FOR DISTILLER'S LICENCE

Reg. 3 (1)

Form Sale 39

Date..... 19.....

The Secretary,  
Board of Customs and Excise,  
Mosaic House, Lagos.

Thro' Chief Collector,  
Custom House,

..... whose \*registered/head  
\*I/We.....  
office is at.....

(Office address—Post Office Box or Mail Bag No. NOT acceptable)  
hereby apply for a Distiller's Licence to enable \*me/us carry on business  
as a distiller at.....

(address of premises)

2. The correct description of the premises and all vessels, utensils, pipes,  
fittings and equipments intended to be used in the manufacture of spirits  
and the processes of manufacture are as follows :

- (a) Premises.....  
.....  
.....  
.....  
.....
- (b) Vessels, equipments, etc. ....  
.....  
.....  
.....  
.....
- (c) Processes of Manufacture.....  
.....  
.....  
.....  
.....

\*I/We annex hereto, in quadruplicate, the plans and drawings distinctly showing the premises and the construction, course, description and use of all equipment, and fixed pipes to be used together with the branches, connections, fitments, utensils and vessels thereon :

- Annex A—\*Plan/Drawing No. ....
- Annex B—.....
- Annex C—.....
- etc. ....

\*I/We undertake to make entry of the premises and to comply with the provisions of the excise laws relating to the distillery industry and the manufacture of spirits.

Office  
Date  
Stamp

.....  
*Applicant*

- \*(a) Application approved,  
Distiller's Licence to be issued under the following conditions :
- \*(b) Application rejected for the following reasons :

.....  
.....  
.....

Office  
Date  
Stamp

.....  
*for the Board*

Distiller's Licence No. ....of.....issued.

Office  
Date  
Stamp

.....  
*for Chief Collector*

.....  
*Area*

\* Delete where inapplicable.  
(206/0/147)

TO BE COMPLETED IN DUPLICATE

(Reg. 3 (2))

SECOND SCHEDULE  
 CUSTOMS AND EXCISE, (NIGERIA)  
 DISTILLER'S LICENCE

Form Ex. 2

No. ....19.....

Pursuant to Section 1 of the Excise (Control of Distillation) Act 1964,  
 and the Regulations made thereunder,

.....  
 (Name of Distiller)

whose \*Registered/Head Office is at .....

\*is/are hereby licensed as a Maker or Distiller of Spirits on \*his/their  
 premises at .....

under Excise Factory No. ...., subject to the following  
 conditions :

- (1) The licensee shall comply with the provisions of the excise laws relating to the making or distillation of spirits and any conditions prescribed by the Board under those laws.
- (2) The licensee shall display this license in a conspicuous place at \*his/their licensed premises.
- (3) This licence is not transferable.
- (4) This licence expires on 31st December, 19..... but may at any time be revoked in accordance with the provisions of the excise laws.
- (5) Special conditions (if any).....

Fee of £100 (one hundred pounds) paid on Customs and Excise Receipt  
 No. .... of .....

Dated at ..... this day of ..... 19.....

Office  
 Date  
 Stamp

.....  
 for the Board

This licence is accepted by \*me/us subject to the conditions stated hereon.

Office  
 Date  
 Stamp

.....  
 Licensee

\* Delete where inapplicable.  
 (206/0/139).

B 236

L.N. 80 of 1965

THE CONSTITUTION OF THE FEDERATION  
(1963 No. 20)

**Exercise of Functions by Superior Police Officers (Consent)**  
**Notice 1965**

In exercise of the powers conferred by subsection (2) of section one hundred of the Constitution of the Federation, the President has given his consent to the exercise by superior police officers of the functions conferred upon them by the Gombe Native Authority (Native Liquor) Rules, 1965.

DATED at Lagos this 29th day of June 1965.

R. C. ONYEJEPU,  
*Acting Deputy Secretary to the  
Council of Ministers*

CUSTOMS TARIFF ACT, 1958  
 (No. 60 OF 1958)

Customs Tariff (Duties and Exemptions) (No. 6) Order, 1964  
 Commencement : 16th July, 1964

In exercise of the powers conferred by subsection (1) of section 6 of the Customs Tariff Act, 1958, the President has made the following Order—

1. This Order may be cited as the Customs Tariff (Duties and Exemptions) (No. 6) Order, 1964, and shall apply throughout the Federation.

2. The First Schedule to the Customs Tariff Act, 1958 (which relates to the import duties of Customs) as the same was replaced by the Customs Tariff (Duties and Exemptions) Order, 1962, is amended—

(a) by the deletion of item 5 and the substitution therefor of the following—

“(5) BAGS AND SACKS (other than bags loosely sewn) of textile material—

- (1) of jute with dimensions not exceeding 44" x 28" shown to the satisfaction of the Board to be imported for the packing of goods and produce manufactured, grown or processed in Nigeria .. .. . each .. .. . 0 0 2

(2) Other

- (a) Imported for the packing of goods by an importer approved in that behalf by the Minister .. .. . each .. .. . 0 0 2
  - (b) Other .. .. . each .. .. . 0 1 4
- or *ad valorem* 20 per centum, whichever is the higher.

(b) By the deletion in sub-item (1) (a) of item 45 of the amount “0 2 6” and the substitution therefor of the amount “0 3 3”

(c) By the deletion of item 63 and the substitution therefor of the following—

“63. YARNS AND THREADS of cotton and/or artificial silk :

- (1) Yarns imported for use in the manufacture of blankets or sanitary towels by a manufacturer approved in that behalf by the Minister .. .. . the pound (net thread weight) 0 0 4

Short title and application.  
 Amendment of First Schedule to No. 60 of 1958.  
 L.N. 25 1962.

- (2) Waste yarns imported for use in the manufacture of blankets by a manufacturer approved in that behalf by the Minister .. .. . the pound (net thread weight) .. 0 0 1
- (3) Sewing threads .. .. . the pound (net thread weight) .. 0 5 6  
or *ad valorem* 20 per centum whichever is the higher.
- (4) Darning, crocheting, sewing (excluding sewing thread) or embroidery .. .. . the pound (net thread weight) .. 0 4 0  
or *ad valorem* 20 per centum, whichever is the higher.
- (5) All other .. .. . the pound (net thread weight) .. 0 1 2

MADE at Lagos this 14th day of June, 1964.

R. C. ONYEJEPU,  
*Acting Deputy Secretary to  
the Council of Ministers*

#### EXPLANATORY NOTE

This Order has the following effects—

- (a) it increases the import duty on :—
- (i) Sewing threads from 4s the pound to 5s-6d the pound.
  - (ii) Knitted fabrics from 2s-6d the pound to 3s-3d the pound ;
- (b) it reduces the import duty on :—
- (i) Bags and Sacks of textile materials imported for the packing of goods by an approved importer from 1s-4d each to 2d each.
  - (ii) Yarns imported for use in the manufacture of blankets or sanitary towels from 1s-2d the pound to 4d the pound.

F.10251/S. 86

Supplement to Official Gazette No. 61, Vol. 51, 16th July, 1964—Part B

**L.N. 83 of 1964**

**THE DEFENCE INDUSTRIES CORPORATION OF NIGERIA ACT 1964**  
(1964, No. 14)

**Appointed Day Order**

In exercise of the Powers conferred on me by Section 14 (2) of the Defence Industries Corporation of Nigeria Act, 1964, I, Alhaji Muhammadu Ribadu, Minister of Defence hereby appoint the 1st day of August, 1964 as the date for the coming into operation of the said Act.

DATED at Lagos this 7th day of July, 1964.

MUHAMMADU RIBADU,  
*Minister of Defence*

Gg/1. Sec/180

52

Supplement to Official Gazette No. 62, Vol. 51, 23rd July, 1964—Part B

• L.N. 83 of 1964

DEFENCE INDUSTRIES CORPORATION OF NIGERIA ACT, 1964  
(1964, No. 14)

**The Defence Industries Corporation of Nigeria Act  
(Commencement) Order, 1964**

*Commencement : 1st August, 1964*

In exercise of the powers conferred on me by subsection (2) of Section 14 of the Defence Industries Corporation of Nigeria Act, 1964 and of all other powers enabling me in that behalf, I hereby make the following order—

1. The Defence Industries Corporation of Nigeria Act, 1964 will come into force on the 1st day of August, 1964.
2. This Order may be cited as the Defence Industries Corporation of Nigeria Act (Commencement) Order, 1964.

Commencement.

Citation.

MADE this 7th day of July, 1964.

MUHAMMADU RIBADU,  
*Minister of Defence*

\* This notice cancels L.N. 83 of 1964 published in the Supplement to *Official Gazette* No. 61, Vol. 51, 16th July, 1964.



2. This Notice may be cited as the Open General Import Licence (Dollar Area) (No. 4 of 1959) Amendment Notice 1964 and shall apply throughout the Federation. Citation and application.

MADE in Lagos this 30th day of July, 1964.

J. B. ELUMEZE,  
Import Licensing Authority,  
Federal Ministry of Commerce and Industry

EXPLANATORY NOTE

(This note is not part of the Notice but is intended to explain its effect)  
The effect of this amendment is that specific import licence is now required for the importation into Nigeria from Dollar Area of the goods listed in the above Legal Notice.

L.N. 88 of 1964

CUSTOMS AND EXCISE MANAGEMENT ACT 1958  
(1958, No. 55)

Open General Import Licence (All Countries) (No. 1 of 1964)  
Amendment Notice 1964

Commencement : 30th July, 1964

In exercise of the powers conferred by section 4 of the Imports Prohibition Order 1959, the Import Licensing Authority hereby amends the Second Schedule to the Open General Import Licence referred to herein.

1. The Second Schedule to the Open General Import Licence (All Countries) (No. 1 of 1964) is hereby amended by the addition of the following item :-

Amendment of L.N. 56 of 1964.

	Import Group	Item No.
"23. Blankets, other material .. ..	656	69"

2. This Notice may be cited as the Open General Import Licence (All Countries) (No. 1 of 1964) Amendment Notice 1964 and shall apply throughout the Federation.

Citation and application

MADE at Lagos, this 30th day of July, 1964.

J. B. ELUMEZE,  
Import Licensing Authority,  
Federal Ministry of Commerce and Industry

EXPLANATORY NOTE

(This note is not part of the Notice but is intended to explain its effect)  
The effect of this amendment is that specific import licence is now required for the importation into Nigeria from all countries of the goods listed in the above Legal Notice.

L.N. 89 of 1964

CUSTOMS AND EXCISE MANAGEMENT ACT, 1958  
(1958, No. 55)

Open General Import Licence (Netherlands) (No. 2 of 1964)  
Amendment Notice 1964

Commencement : 30th July, 1964

In exercise of the powers conferred by section 4 of the Imports Prohibition Order 1959, the Import Licensing Authority hereby amends the Schedule to the Open General Import Licence referred to herein.

Amendment  
of L.N. 47  
of 1964.

1. The Schedule to the Open General Import Licence (Netherlands) No. 2 of 1964 is hereby amended by the addition of the following item :—

	<i>Import Group</i>	<i>Item No.</i>
“21. Blankets, other material . .	656	69”

Citation  
and applica-  
tion.

2. This Notice may be cited as the Open General Import Licence (Netherlands) (No. 2 of 1964) Amendment Notice 1964 and shall apply throughout the Federation.

MADE at Lagos this 30th day of July, 1964.

J. B. ELUMEZE,  
*Import Licensing Authority,*  
*Federal Ministry of Commerce and Industry*

EXPLANATORY NOTE

*(This note is not part of the Notice but is intended to explain its effect).*

The effect of this amendment is that specific import licence is now required for the importation into Nigeria from Netherlands of the goods listed in the above Legal Notice.

L.N. 90 of 1964

CUSTOMS AND EXCISE MANAGEMENT ACT, 1958  
(No. 55 of 1958)

Small Craft (Amendment) Regulations, 1964

Commencement : 1st August, 1964

In exercise of the power conferred by subsection (1) of section 69 of the Customs and Excise Management Act, 1958, and of all other powers enabling him in that behalf, the President has made the following Regulations—

Citation  
and applica-  
tion.

1. These Regulations may be cited as the Small Craft (Amendment) Regulations, 1964, and shall apply throughout the Federation.

2. The small Craft Regulations, 1959 (as amended by the Small Craft (Amendment) Regulations, 1963), are amended by the deletion of paragraph (b) of regulation 2 and the substitution therefor of the following :—

“(1) Eastward of West Point Beacon, Calabar River, outside the area bounded by the coasts of Nigeria and a line drawn from a point on a bearing 180 degrees ten nautical miles distant from West Point Beacon to a point on a bearing 180 degrees ten nautical miles distant from East point Calabar River, thence due North to East point, Calabar River.”

MADE at Lagos this 7th day of July, 1964.

I. A. WEMANIBU,  
*Acting Deputy Secretary  
to the Council of Ministers*

Amend-  
ment of  
L.N. 76  
1959. —  
L.N. 95  
1963. —

#### EXPLANATORY NOTE

The purpose of these Regulations is to set out accurately the limits outside which certain small craft may not be used.



Supplement to Official Gazette Extraordinary No. 64, Vol. 51, 3rd August, 1964  
—Part B

L.N. 91 of 1964

CUSTOMS TARIFF ACT, 1958  
(No. 60 of 1958)

The Customs Tariff (Duties and Exemptions) (No. 7)  
Order, 1964

Commencement : 3rd August, 1964

In exercise of the powers conferred by subsection (1) of section 6 of the Customs Tariff Act, 1958, the President hereby makes the following Order—

1. This Order may be cited as the Customs Tariff (Duties and Exemptions) (No. 7) Order, 1964 and shall apply throughout the Federation. Short title and application.
2. The rate at which goods are chargeable with duty under section 4 of the Act shall be increased from twenty per cent to thirty-three one-third per cent ( $33\frac{1}{3}\%$ ) of the value of the goods. Amendment of section 4 of the Act.
3. The First, Second and Third Schedules to the Customs Tariff Act, 1958, as amended from time to time, are revoked and replaced by the following Schedules. Replacement of Schedules to the Act.

FIRST SCHEDULE  
IMPORT DUTIES OF CUSTOMS

£ s d

1. AIR CONDITIONING AND REFRIGERATING EQUIPMENT OF ALL KINDS, and identifiable parts therefor . . . . . *ad valorem* 40 per centum
2. ALCOHOLIC BEVERAGES AND LIQUORS :—
  - (1) Beer of an original gravity of not more than 1,040° . . . . . the gallon . . . 0 15 0  
For each additional degree of original gravity . . . . . the gallon . . . +0 0 0 $\frac{1}{2}$
  - (2) Cider and Perry . . . . . the gallon . . . 0 15 0
  - (3) Distilled :—
    - (a) Bitters, brandy, gin, liqueurs, rum and whisky . . . . . the gallon . . . 10 10 0
    - (b) Other distilled potable alcoholic beverages, including spirits of wine and pure alcohol but not including medicinal preparations . . . . . the gallon . . . 10 10 0  
or *ad valorem* 100 per centum, whichever is the higher.
    - (c) Medicinal preparations which contain 10 per cent or more by volume of ethyl alcohol, naphtha or methyl alcohol (methanol) purified so as to be potable . . . the gallon . . . 10 10 0  
or *ad valorem* 100 per centum, whichever is the higher.

(d) Perfumed . . . . . the gallon . . . . . £ s d  
 or *ad valorem* 100 per centum, 10 10 0  
 whichever is the higher.

Sub-item (b) includes only liquids which contain 2½ per cent or more by volume of ethyl alcohol, naphtha or methyl alcohol (methanol), purified so as to be potable.

Sub-item (d) includes any perfumed liquid containing alcohol of any kind.

(4) Wine and Must, of fresh grapes :—

(a) Sparkling . . . . . the gallon . . . . . 7 4 0

(b) Other, including still wine, grape must containing alcohol and fermented grape must . . . . . the gallon . . . . . 2 8 0

(5) Methylated and denatured spirits and other non-potable alcohol accepted as such by the Board . . . . . *ad valorem* 33½ per centum.

3. APPAREL INCLUDING ACCESSORIES FOR APPAREL, not elsewhere specified or included in this Schedule :—

(1) Footwear other than gaiters, leggings, puttees and spats :—

(a) Children's wear, accepted as such by the Board . . . . . *ad valorem* 33½ per centum

(b) Other :—

(i) made principally of canvas and rubber or of either . . . . . the pair . . . . . 0 6 0  
 or *ad valorem* 40 per centum, whichever is the higher ;  
 the pair . . . . . 0 10 6  
 or *ad valorem* 40 per centum, whichever is the higher ;

(ii) made of other materials . . . . .

(2) Handkerchiefs, headties, mufflers, sarongs, scarves and similar articles, of a greater area than one-third of a square yard . . . . .

the square yard . . . . . 0 1 9  
 or *ad valorem* 40 per centum, whichever is the higher ;

(3) Hose and stockings including babies' bootees . . . . .

each . . . . . 0 0 8  
 or *ad valorem* 40 per centum, whichever is the higher ;

(4) Outerwear, of textile materials :—

(a) Aprons, bathing costumes of all kinds, blouses, cardigans, frocks, housecoats, jerseys, overalls and similar protective garments ; pullovers, shorts and waistcoats

each . . . . . 0 2 6  
 or *ad valorem* 40 per centum, whichever is the higher ;

£ s d

- (b) Jackets, Gents' Trousers (including jodhpurs and riding breeches) and Ladies' Slacks .. each .. .. 0 7 6  
or *ad valorem* 40 per centum,  
whichever is the higher.
- (c) Dressing gowns, skirts .. .. each .. .. 0 4 6  
or *ad valorem* 40 per centum,  
whichever is the higher.
- (5) Shirts .. .. .. each .. .. 0 5 0  
or *ad valorem* 40 per centum,  
whichever is the higher.
- (6) Singlets .. .. .. each .. .. 0 3 6  
or *ad valorem* 40 per centum,  
whichever is the higher.
- (7) Undergarments and nightwear :—
- (a) Chemises, undervests, under-shorts, brassiers, drawers, pantees and similar articles not elsewhere specified or included in this Schedule .. .. each .. .. 0 1 3  
or *ad valorem* 40 per centum,  
whichever is the higher.
- (b) Camisoles, cami-knickers, corsets, nightwear, petticoats, slips and underskirts .. .. .. each .. .. 0 2 6  
or *ad valorem* 40 per centum,  
whichever is the higher.
- (8) Other, not elsewhere specified or included in this Schedule, including gloves, complete two-piece gents' suits and other made-up accessories for articles of apparel .. .. *ad valorem* 40 per centum.
4. APPAREL and household rummage showing signs of appreciable wear ; rags .. the pound .. 0 1 3  
or *ad valorem* 40 per centum,  
whichever is the higher.
5. BAGS AND SACKS (other than bags loosely sewn) of textile material :—
- (1) Of jute with dimensions not exceeding 44" x 28" shown to the satisfaction of the Board to be imported for the packing of goods .. .. each .. .. 0 0 2
- (2) Other .. .. .. each .. .. 0 1 4
6. BASKETWORK, WICKERWORK AND LOOFAH and articles made therefrom not elsewhere specified or included in this Schedule .. .. *ad valorem* 66 $\frac{2}{3}$  per centum.
7. BEADS .. .. .. the pound gross 0 1 0  
or *ad valorem* 40 per centum,  
whichever is the higher.

8. BED QUILTING, BED QUILTS, BED SHEETS, BED SPREADS, DUSTERS, NAPKINS, PILLOW-CASES, TABLE CLOTHS, TOWELS AND OTHER similar made-up household articles of textile material not elsewhere specified or included in this Schedule .. .. . *ad valorem 40 per centum.*
9. BICYCLES AND TRICYCLES whether imported assembled or in parts to be assembled .. .. . each .. .. . 3 0 0  
or *ad valorem 33 $\frac{1}{3}$  per centum*, whichever is the higher.
10. BLANKETS AND RUGS .. .. . each .. .. . 0 4 0  
or *ad valorem 50 per centum*, whichever is the higher.
11. BROADCAST RECEIVERS, DOMESTIC :—  
(1) Sound receivers .. .. . *ad valorem 50 per centum.*  
(2) Television receivers .. .. . *ad valorem 50 per centum.*  
(3) Radiograms .. .. . *ad valorem 66 $\frac{2}{3}$  per centum.*
12. CAMERAS AND PROJECTORS, parts thereof, appliances used in connection therewith, epidiascopes, episcopes and magic lanterns .. .. . *ad valorem 66 $\frac{2}{3}$  per centum.*
13. CARPETS, carpetting, floor rugs, linoleum, mats, matting, and tapestries of any material .. .. . *ad valorem 50 per centum.*
14. CEMENT CLINKER .. .. . the ton .. .. . 1 15 0  
or *ad valorem 20 per centum*, whichever is the higher.
15. CEMENT, PORTLAND, and similar cements for building purposes .. .. . the ton .. .. . 5 0 0  
or *ad valorem 75 per centum*, whichever is the higher.
16. CHINAWARE AND POTTERY other than builders' fittings, suitable for hotel, household and restaurant use or for personal adornment .. .. . *ad valorem 50 per centum.*
17. CINEMATOGRAPH FILMS CONTAINING pictures for exhibition, whether developed or not :—  
(1) Not exceeding 16 mm. in width .. the hundred feet 0 5 0  
(2) Other .. .. . the hundred feet 0 10 0
18. CLOCKS AND WATCHES .. .. . each .. .. . 0 7 6  
or *ad valorem 50 per centum*, whichever is the higher.

	£	s	d
19. COPPER AND ALLOYS OF COPPER, including brass, the following :— plates, sheet, strip, circles, sections and rods, cut to size but not further worked .. .. .			
	<i>ad valorem 15 per centum.</i>		
20. CUTLERY, including kitchen and table knives, forks and spoons of base metal, including plated .. .. .			
	<i>ad valorem 50 per centum.</i>		
21. ELECTRIC AND ELECTROTHERMIC APPARATUS AND APPLIANCES not elsewhere specified or included in this Schedule .. .. .			
	<i>ad valorem 40 per centum.</i>		
22. ELECTRIC BATTERIES, all types including dry batteries and accumulators .. .. .			
	<i>ad valorem 40 per centum.</i>		
23. FILMS (STILL), plates and paper unexposed, for photography .. .. .			
	<i>ad valorem 50 per centum.</i>		
24. FILMS, CINEMATOGRAPH, of sizes commonly known as 8 mm. and 9.5 mm., unexposed .. .. .			
	<i>ad valorem 50 per centum.</i>		
25. FIREWORKS .. .. .			
	<i>the pound gross 0 10 0</i>		
26. FLOWERS AND FOLIAGE, whether natural or not, for decorative purposes .. .. .			
	<i>ad valorem 66<math>\frac{2}{3}</math> per centum.</i>		
27. FURNITURE including framed mirrors, ornaments, framed pictures and photographs, and similar articles :— (1) Metal office furniture and cabinets. . . . .			
	<i>ad valorem 50 per centum.</i>		
(2) Other, including bed mattresses of all materials .. .. .			
	<i>ad valorem 75 per centum.</i>		
28. FURSKINS, dressed, and articles thereof, not elsewhere specified or included in this Schedule .. .. .			
	<i>ad valorem 100 per centum.</i>		
29. GLASS TABLEWARE AND other articles of glass for hotel, household, and restaurant use, not including plate and sheet glass; vacuum bottles, bowls and jars; glass ornaments .. .. .			
	<i>ad valorem 40 per centum.</i>		
30. GRAMOPHONE RECORDS .. .. .			
	<i>ad valorem 66<math>\frac{2}{3}</math> per centum.</i>		
31. GRAMOPHONES AND RECORD PLAYERS .. .. .			
	<i>ad valorem 66<math>\frac{2}{3}</math> per centum.</i>		
32. GREASE, LUBRICATING .. .. .			
	the pound	0	0
33. GUNPOWDER .. .. .			
	the pound	0	7
34. HAIR PADS, HAIR NETS, WIGS, FALSE BEARDS, and similar articles of human, animal or artificial hair .. .. .			
	<i>ad valorem 100 per centum.</i>		
35. HAND IMPLEMENTS, hand tools and parts thereof: agricultural, horticultural, artisans' and labourers' .. .. .			
	<i>ad valorem 20 per centum.</i>		

36. HOUSEHOLD UTENSILS, WHOLLY or mainly manufactured of metal, whether enamelled or not .. .. . *ad valorem 50 per centum.*
37. IRON and STEEL PRODUCTS, namely, plates, sheets, strip universals uncoated ; joists, girders, angles, sections and bars cut to size but not further worked, excluding concrete reinforcing rounds ; castings and forgings not further worked .. .. . *ad valorem 15 per centum.*
38. JEWELLERY, including imitation jewellery and rolled gold, enamel or gilt jewellery, precious and semi-precious stones and pearls and imitations thereof ; goldsmiths' and silversmiths' wares .. .. . *ad valorem 100 per centum.*
39. LAMPS, PORTABLE, electric battery operated and non-electric, but not including wick-type hurricane lamps .. .. . *ad valorem 40 per centum.*
40. LIGHTERS, MECHANICAL, and similar lighters including chemical and electric lighters complete or incomplete (including bodies) .. .. . each .. .. . 0 5 0  
or *ad valorem 66 $\frac{2}{3}$  per centum,*  
whichever is the higher ;
- Parts for the above .. .. . *ad valorem 66 $\frac{2}{3}$  per centum.*
41. LIME .. .. . the ton gross .. 3 0 0
42. MATCHES :  
In boxes containing 80 matches or less For the purpose of this Item, four "booklets" of matches shall be regarded as a box. Matches in boxes containing a greater quantity than 80 each to be charged in proportion. the gross boxes 2 8 0
43. NAILS, BARBED IRON OR STEEL WIRE, SINGLE FLAT WIRE, BARBED OR NOT, AND LOOSELY TWISTED BARBED WIRE of the kind used for fencing, of iron or steel ; netting, fencing, reinforcing fabric and similar materials of iron or steel wire .. .. . the pound .. 0 0 2  
or *ad valorem 33 $\frac{1}{3}$  per centum,*  
whichever is the higher.
44. OFFICE MACHINERY, including typewriters, book-keeping and calculating machines, dictating machines and tape recorders, including parts therefor .. .. . *ad valorem 40 per centum.*

£ s d

## 45. OILS :—

(1) Gas or diesel oils suitable for use in internal combustion engines :—

(a) for use by the Nigerian Coal Corporation, the Nigerian Railway Corporation, the Electricity Corporation of Nigeria, the Nigerian Electricity Supply Company Ltd., or the Nigerian Ports Authority, other than in road vehicles .. .. . the gallon .. 0 0 4

(b) Other .. .. . the gallon .. 0 1 9

(2) Illuminating, including kerosene and other refined burning oils .. .. the gallon .. 0 1 0

(3) Lubricating .. .. . the gallon .. 0 1 0

(4) Motor spirit and products ordinarily used as such; benzine, bensoline, naphtha (non-potable), gasoline, petrol and petroleum, all kinds of shale and coal tar spirits but not including kerosene and other refined

burning oils .. .. . the gallon .. 0 1 9  
ad valorem 33 $\frac{1}{3}$  per centum.

(5) Essential .. .. . the gallon .. 0 1 6

(6) All other, not elsewhere specified or included in this Schedule .. .. or ad valorem 33 $\frac{1}{3}$  per centum, whichever is the higher.45A. PAINT, enamel, lacquers and varnishes the pound .. 0 0 10  
or ad valorem 33 $\frac{1}{3}$  per centum, whichever is the higher.

## 46. PAPER :—

(1) Paperboard (cardboard) including corrugated cardboard but excluding building board, in uncut rectangular sheets of a size not less than 16 inches by 15 inches .. .. ad valorem 15 per centum.

(2) Printing and writing paper, other than newsprint, namely, plain or composite paper in reels of not less than 9 inches wide, or flat or folded in the original mill ream wrapper of a size not less than 16" x 15" .. .. ad valorem 15 per centum.

(3) Toilet .. .. . ad valorem 33 $\frac{1}{3}$  per centum.

(4) Other paper and paper manufactures .. .. ad valorem 25 per centum.

47. PENS, fountain and ball point; propelling pencils .. .. . ad valorem 40 per centum.

48. PERFUMERY, COSMETICS and TOILET PREPARATIONS, not including dentifrices, medicated dusting powders accepted as such by the Board, mouth washes, perfumed alcohol, toilet soap . . . . *ad valorem 100 per centum.*
49. PIECE GOODS :—
- (1) Of cotton, flax, natural silk, man-made fibres (other than glass or metal), wool or other animal hair or ramie, or mixture thereof :—
- (a) Cotton fabrics, bleached and unbleached . . . . . the sq. yard . . . 0 1 3  
or *ad valorem 33½ per centum*,  
whichever is the higher.
- (b) Knitted fabrics . . . . . the pound . . . 0 3 3  
or *ad valorem 50 per centum*,  
whichever is the higher.
- (c) Unbleached grey baft imported for use exclusively for the production of printed cotton fabrics by a manufacturer approved in that behalf by the Minister . . . the square yard . . . 0 0 4.8
- (d) Velvet, velveteen, plushes and other pile fabrics . . . . . the square yard . . . 0 4 0  
or *ad valorem 50 per centum*,  
whichever is the higher.
- (e) Other . . . . . the square yard . . . 0 2 0  
or *ad valorem 40 per centum*,  
whichever is the higher.
- (2) Of other textile material (other than textile fibres made of spun glass or of metal) :—
- (a) For use exclusively for the manufacture of tarpaulin by a manufacturer approved in that behalf by the Minister . . . . . *ad valorem 25 per centum.*
- (b) Other . . . . . *ad valorem 40 per centum.*
- For the purpose of this Item, "Piece Goods" shall include any remnants of cloth of irregular length of a greater area than one-third of a square yard.
50. PLASTICWARE . . . . . *ad valorem 50 per centum.*
51. PROVISIONS :—
- (1) Biscuits and Bakery Products :—
- (a) Biscuits . . . . . *ad valorem 66⅔ per centum.*
- (b) Other bakery products . . . . . *ad valorem 40 per centum.*
- (2) Butter, cheese and edible fats of all kinds not elsewhere specified or included in this Schedule . . . . . the pound . . . 0 1 6

- |  | £   | s | d |
|--|---|---|---|
| (3) Chocolate confectionery in block or tablet form whether "Plain" or "Milk" consisting wholly of chocolate or with the sole addition of fruit or nut or both .. .. . |   |   |   |
|  | <i>ad valorem</i> 12½ per centum.                             |   |   |
| (4) Chocolate powder, cocoa beans, cocoa butter, cocoa paste and cocoa powder .. .. .  |   |   |   |
|  | the pound .. 0 0 4  |   |   |
| (5) Coffee, whether roasted or not, coffee extracts, coffee essences, coffee powders and coffee substitutes .. .. .  |   |   |   |
|  | <i>ad valorem</i> 66⅔ per centum.                             |   |   |
| (6) Confectionery of all kinds including candied and crystallised fruits, not elsewhere specified or included in this Schedule .. .. .                                 |   |   |   |
|  | the pound .. 0 1 3  |   |   |
|  | or <i>ad valorem</i> 66⅔ per centum, whichever is the higher. |   |   |
| (7) Crustaceans, molluscs, caviar and caviar substitutes, fresh or preserved in any way .. .. .  |   |   |   |
|  | <i>ad valorem</i> 50 per centum.                              |   |   |
| (8) Fish, all kinds, not elsewhere specified or included in this Schedule .. .. .  |   |   |   |
|  | <i>ad valorem</i> 50 per centum.                              |   |   |
| (9) Flour and meal of wheat and spelt (including meslin) .. .. .   |   |   |   |
|  | the ton .. 25 0 0   |   |   |
|  | or <i>ad valorem</i> 50 per centum, whichever is the higher.  |   |   |
| (10) Fruit juices, unfermented (including grape must not elsewhere specified or included in this Schedule), fruit syrups, fruit cordials and squashes .. .. .          |   |   |   |
|  | <i>ad valorem</i> 66⅔ per centum.                             |   |   |
| (11) Fruit, whether fresh or preserved, including canned and frozen .. .. .  |   |   |   |
|  | <i>ad valorem</i> 50 per centum.                              |   |   |
| (12) Jams, marmalades, fruit jellies (but not table jellies), honey .. .. .  |   |   |   |
|  | <i>ad valorem</i> 66⅔ per centum.                             |   |   |
| (13) Meat, all kinds, including poultry .. .. .  |   |   |   |
|  | <i>ad valorem</i> 66⅔ per centum.                             |   |   |
| (14) Pet foods of all kinds .. .. .  |   |   |   |
|  | <i>ad valorem</i> 50 per centum.                              |   |   |
| (15) Salt .. .. .  |   |   |   |
|  | the ton .. 4 0 0  |   |   |
|  | or <i>ad valorem</i> 20 per centum, whichever is the higher.  |   |   |
| (16) Stockfish .. .. .   |   |   |   |
|  | the pound .. 0 0 1  |   |   |
| (17) Sugar .. .. .   |   |   |   |
|  | the pound .. 0 0 2  |   |   |
| (18) Table waters, including mineral waters of all descriptions .. .. .  |   |   |   |
|  | <i>ad valorem</i> 75 per centum.                              |   |   |
| (19) Tea and mate, tea powders and extracts .. .. .  |   |   |   |
|  | <i>ad valorem</i> 66⅔ per centum.                             |   |   |
| (20) Foodstuffs and beverages not elsewhere specified or included in this Schedule .. .. .   |   |   |   |
|  | <i>ad valorem</i> 40 per centum.                              |   |   |

## 52. ROAD MOTOR VEHICLES :—

(1) Passenger cars, including station wagons and estate cars, but not including pick-ups, vehicles with fitted seats for more than ten persons excluding the driver, or four-wheel drive vehicles :—

(a) engine capacity not exceeding 1750 c.c. . . . .

*ad valorem* 33 $\frac{1}{3}$  per centum.

(b) exceeding 1750 c.c. but not exceeding 2750 c.c. . . . .

*ad valorem* 50 per centum.

(c) exceeding 2750 c.c. but not exceeding 3500 c.c. . . . .

*ad valorem* 75 per centum.

(d) exceeding 3500 c.c. . . . .

*ad valorem* 100 per centum.

(2) Motor buses and coaches with fitted seats for 20 or more passengers, imported :—

(a) assembled . . . . .

*ad valorem* 10 per centum.

(b) unassembled, for assembly by a manufacturer approved in that behalf by the Minister . . . . .

*ad valorem* 5 per centum.

(3) Other road motor vehicles including motor bicycles and motorised bicycles . . . . .

*ad valorem* 25 per centum.

(4) Parts for road vehicles not elsewhere specified or included in this Schedule . . . . .

*ad valorem* 33 $\frac{1}{3}$  per centum.

For the purposes of this item, parts imported for assembly into new vehicles mentioned in (1) and (3) above shall be assessed for duty at the rate appropriate to the complete vehicle.

## 53. ROOFING MATERIALS :—

(1) Corrugated sheets :—

(a) of galvanised iron or aluminium

the square foot 0 0 1 $\frac{1}{2}$   
or *ad valorem* 20 per centum,

whichever is the higher.

(b) of all other materials . . . . .

*ad valorem* 20 per centum.

(2) Ridgings . . . . .

*ad valorem* 20 per centum.

54. RUBBER FABRICATED MATERIAL for tyre retreading, namely, camelback (rubber compound strips), gum-dipped cotton or rayon fabric, retreading cement and tread cushion and tube gums . . . . .

*ad valorem* 33 $\frac{1}{3}$  per centum.

55. SACCHARIN and similar sweetening substances . . . . .

the ounce . . . 0 10 0  
or *ad valorem* 50 per centum,  
whichever is the higher.

56. SEWING MACHINE PARTS and hardware items imported for use in the assembly of sewing machines and serving machine cabinet respectively by a manufacturer approved in that behalf by the Minister

*ad valorem* 15 per centum.

57. SHOT GUNS and air guns, including air rifles . . . . .

*ad valorem* 50 per centum.

£ s d

58. SMOKING PIPES, CIGAR AND CIGARETTE HOLDERS and similar articles, and parts therefor .. .. . *ad valorem* 50 per centum.
59. SOAP and SOAP PRODUCTS, including detergents whether manufactured from soap or not .. .. . the pound .. 0 0 9  
or *ad valorem* 50 per cent  
whichever is the higher.
60. SODA caustic :—  
(1) for a manufacturer approved in that behalf by the Minister .. .. the hundred weight 1 15 0  
(2) Other .. .. . the hundred weight 2 0 0
61. STEAM VESSELS, BARGES, BOATS, LAUNCHES AND LIGHTERS not exceeding 250 gross tons, imported assembled or in sections to be assembled locally :—  
(1) Pleasure craft, touring launches and commercial craft of a range not exceeding 100 feet in length .. .. *ad valorem* 50 per centum.  
(2) Other, except where the Minister is satisfied that they cannot be built in Nigeria .. .. . *ad valorem* 33½ per centum.  
(3) Fittings, spare parts and dynamos for marine inboard engines, stern tubes, propeller shaft, propeller and empty bare hulls imported for the construction of steam or motor vessels, by a local boatyard approved in that behalf by the Minister .. .. *ad valorem* 20 per centum.
62. SYNTHETIC PERFUME MATERIALS AND CONCENTRATES AND ENFLEURAGE GREASES :—  
(1) for a manufacturer approved in that behalf by the Minister .. .. *ad valorem* 33½ per centum.  
(2) Other .. .. . *ad valorem* 100 per centum.
63. TEXTILE ARTICLES, made-up, whether or not impregnated or coated, not elsewhere specified or included in this Schedule .. .. *ad valorem* 40 per centum.
64. TOBACCO :—  
(1) Manufactured :—  
(a) Cigars .. .. . the pound .. 2 15 0  
(b) Cigarettes .. .. . the pound .. 2 15 0  
or £6-15s-0d the thousand  
cigarettes, whichever is the  
higher.  
(c) Other, including snuff .. .. the pound .. 2 0 0

- (2) Unmanufactured :—
- (a) imported for the manufacture of cigarettes by any person licensed to manufacture cigarettes under the provisions of the Customs and Excise Management Act, 1958 .. .. . the pound .. 0 15 3
- (b) Other .. .. . the pound .. 1 0 0
65. TRAVELLING TRUNKS, travel bags, handbags, portmanteaux, purses, suitcases and wallets of all materials :—
- (1) imported nested .. .. . each article .. 0 6 0  
or *ad valorem* 40 per centum,  
whichever is the higher.
- (2) Other .. .. . *ad valorem* 40 per centum.
66. TYRES :—
- (1) Pneumatic :—
- (a) Of a sectional width exceeding 4" (101 mm.) and less than 12" (305 mm.) and tubes and flaps therefor but excluding :—
- (i) tyres pneumatic designed for agricultural tractors, agricultural and industrial implements, earth movers, graders and similar machines, and tubes and flaps therefor, and so invoiced ;
- (ii) tyres pneumatic designed for aircraft and tubes therefor and so invoiced .. .. . the pound weight 0 3 6
- (b) Other, unless specifically exempted under an item in the Second Schedule :—
- (i) of a sectional width exceeding  $1\frac{1}{2}$ " and tubes and flaps therefor *ad valorem* 33 $\frac{1}{3}$  per centum.
- (ii) of a sectional width not exceeding  $1\frac{1}{2}$ " and tubes therefor *ad valorem* 20 per centum.
- (2) Other .. .. . *ad valorem* 20 per centum.
67. UMBRELLAS AND PARASOLS .. .. . each .. .. 0 5 0  
or *ad valorem* 40 per centum,  
whichever is the higher. ,
68. UMBRELLA COVERS .. .. . each .. .. 0 2 0  
or *ad valorem* 40 per centum  
whichever is the higher.
69. WIRE, uncoated, of base metal, single strand :—
- (a) for a manufacturer approved in that behalf by the Minister .. .. . *ad valorem* 10 per centum.
- (b) Other .. .. . *ad valorem* 33 $\frac{1}{3}$  per centum.

## 70. YARNS AND THREADS of cotton and/or artificial silk :—

£ s d

(1) Crotcheting, darning, embroidery ; sewing (other than sewing thread) ..	the pound (net weight) ..	0	4	0
	or <i>ad valorem</i> 33 $\frac{1}{3}$ per centum, whichever is the higher.			
(2) Sewing thread .. .. .	the pound (net weight) ..	0	5	6
	or <i>ad valorem</i> 33 $\frac{1}{3}$ per centum, whichever is the higher.			
(3) Waste yarns, for use in the manufacture of blanket or towel by a manufacturer approved in that behalf by the Minister .. .. .	the pound (net weight) ..	0	0	1
(4) Yarns, for use by a manufacturer approved in that behalf by the Minister .. .. .	the pound (net weight) ..	0	0	4
(5) Other .. .. .	the pound (net weight) ..	0	1	2

For the purpose of this Item artificial silk shall include rayon and other textile fibres prepared from natural or synthetic sources by a chemical process of solution followed by extrusion but shall not include textile fibres made of spun glass or metal.

71. All goods imported and not specified or included in this Schedule or in the Second Schedule .. .. . *ad valorem* 33 $\frac{1}{3}$  per centum.

## SECOND SCHEDULE

### EXEMPTION FROM IMPORT DUTIES OF CUSTOMS

1. ACETIC ACID, formic acid, hydrochloric acid, sulphuric acid and ammonia liquor.
2. Advertising material to the extent permitted by and subject to conditions prescribed in the Customs (Commercial Samples and Advertising Materials) Regulations, 1956.
3. AIRCRAFT, their parts and components, and if the Board is satisfied that the same are imported solely for direct use in the operation of aircraft or the maintenance or repair of aircraft or their parts, the following items and parts and components of the same :—
  - (1) air-conditioning plant ;
  - (2) catering equipment ;
  - (3) engine starting trolleys ;
  - (4) freight hoists ;
  - (5) fuelling plants ;

- (6) inspection platforms ;
- (7) instruments ;
- (8) materials for internal or external repair, renovation, decoration or edecoration ;
- (9) passenger gangways ;
- (10) tools (including machine tools) and machinery (other than vehicles).

b. Animals and Birds, living.

5. APPARATUS AND APPLIANCES designed for the correction, support or elioration of bodily disabilities, including invalid chairs and carriages ether self-propelled or not.

5. Articles, the following, for the manufacture of the goods specified, ported by a manufacturer approved in that behalf by the Minister :—

<i>Article</i>	<i>Goods to be Manufactured</i>
(1) Aluminium and aluminium alloys, unwrought .. .. .	—
(2) Asbestos, crude, washed or ground	—
(3) Cigarette paper, by the roll ..	Cigarettes
(4) Cordage and rope, not less than one-quarter ( $\frac{1}{4}$ ) inch diameter, of any materials other than steel .. ..	—
(5) Wire steel and multi-strand ..	Tyres
(6) Tyres cord, of textile materials other than cotton .. .. .	Tyres
(7) Ferro alloys of manganese and silicon in primary forms .. .. .	—
(8) Fire bricks, fire clay, fire cement and furnace cement .. .. .	—
(9) Blending agents, flavouring concentrates, and neutral blending alcohol	Potable alcoholic liquor
(10) Fluorspar, crude .. .. .	—
(11) Glass, in the mass, the following :— frits, powdered vitrite .. .. .	—
(12) Gypsum .. .. .	Cement
(13) Iron and steel namely :—ingots, blooms, slabs billiets, sheet bars, tinplate bars and equivalent primary forms .. .. .	—
(14) Jute, raw .. .. .	—
(15) Lead, unwrought and simply worked	—
(16) Leather and textile materials ..	Shoes

(17) Phenol formaldehyde, gelatin pearl glue and extruder powder used with such substances .. .. .

(18) Iron and steel products, namely, plates, sheets, strip universals uncoated ; joists, girders, angles sections and bars cut to size but not further worked, excluding concrete reinforcing rounds ; castings and forgings not further worked .. .. .

(19) Pigments, colouring materials and dyestuffs, but not including washing blue, prepared paints and distempers .. .. .

(20) Splints and skillets .. .. .

(21) Plastic materials, synthetic, in powder, liquid or solid (but not sheet) or granule form .. .. .

(22) Tinplate of iron and steel, not exceeding .016 inch guage unworked .. .. .

7. ASPHALT, bitumen, tar and pitch.

8. BANK AND CURRENCY NOTES, Bullion and Coin. For the purposes of this item "bullion" means unrefined gold and silver in amalgam or lumps and bars and refined gold and silver in bars.

9. BOOKS, documents and other matter, printed, or produced by any duplicating processes other than printing, or in manuscript (including typescript), including periodicals and newspapers (other than periodicals and newspapers imported for packing purposes), atlases, catalogues and price lists, charts, globes, maps, music and religious texts, plans, postage and revenue stamps, but excluding almanacs, calendars and stationery.

10. CANOES of a type indigenous to West Africa.

11. CHURCH EQUIPMENT, accepted by the Board as suitable and intended solely for use at religious service.

12. Commercial samples to the extent permitted by and subject to the conditions prescribed in the Customs (Commercial Samples and Advertising Materials) Regulations, 1956.

13. CRUDE OR RESIDUAL OILS ordinarily used as bunker or furnace fuel and not suitable for use in internal combustion engines.

14. CUPS, MEDALS and other trophies, not being articles of general utility, proved to the satisfaction of the Board to be imported for presentation—

(1) as prizes at public examination, exhibitions or shows, or for competitions of skill or sport open to the public or members of recognised clubs and associations ;

(2) for bravery, good conduct or humanity, for excellence in art, industry, invention, learning or science or for honourable or meritorious public services.

15. **EXPLOSIVES**, not including gunpowder or fireworks, being blasting compounds, fuses and detonators suitable and intended for blasting and not suitable for use as fireworks or in firearms.

16. **FILMS**, film strips, microfilms, slides, sound recordings, newsreels, and similar visual and auditory material, passed by the Board of Censors appointed under section 6 of the Cinematograph Ordinance, Cap. 32, as being of educational, scientific or cultural character, if (a) produced by the United Nations or any of its Specialised Agencies or (b) imported by broadcasting, educational or science organisations approved by the Minister.

17. **Films, cinematograph, blanks unexposed**, commonly known as raw film or stock, other than films of sizes commonly known as 8 mm. and 9.5 mm.

18. **FIREARMS** as defined in the Firearms Act (Cap. 69), not including shot guns and air guns and air rifles; sidearms, namely, bayonets, swords and the like; humane killers and cartridges therefor.

19. **FIRE DETECTION, FIGHTING, EXTINGUISHING and ALARM** machinery, apparatus and appliances, and vehicles specially built and equipped for fire fighting.

20. **Fishing Nets and floats.**

21. **FUEL**, lubricants and other products which the Board is satisfied are necessary for, and will be used solely in, the operation of—

- (1) aircraft of the armed forces of a foreign power; or
- (2) civil aircraft registered in a State approved by the President.

22. **Goods for an individual or firm under contract to the Government** where an exemption from the payment of Customs duty on the goods is part of the terms of the contract.

23. **Goods of a charitable nature, and gifts, approved by the Minister—**

- (1) from established bodies recognised by the Governments of their countries;
- (2) from other donors.

24. **HIDES and SKINS** of cattle, sheep and goats, untanned.

25. **LIFEBELTS** and other life saving appliances.

26. **MACHINERY**, apparatus, appliances, instruments and electrical material used in connection therewith for the generation, measurement, transformation, storage, transmission, distribution of, or lighting by, electric power, but not including electroliers, lamps, lamp shades or reflectors, portable batteries, domestic or toilet machines or appliances, electric appliances used in vehicles, and internal combustion engines of the kind used as propulsion units for vehicles.

27. **MACHINERY**, apparatus and appliances but not including machines mainly for domestic use, tanks of iron or steel, toilet machines, weighing machines, vehicles or internal combustion engines suitable for driving vehicles—

- (1) Agricultural;
- (2) Cranes, chain pulleys, bucket and gravity conveyors, hoists, mechanical excavators and winches;

- (3) Dairying ;
- (4) Dental ;
- (5) For use in connection with the preparation of, or prospecting for, any agricultural or forest product of Nigeria ;
- (6) Horticultural ;
- (7) Industrial and manufacturing, including machine tools ;
- (8) Land surveying ;
- (9) Mining and for prospecting for minerals or mineral oils ;
- (10) For water supply, sewerage, drainage or irrigation, the following only—
  - Pipe, piping, tubes, and fittings therefor, other than of cement, asbestos cement or plastic, pumps, rams, lifting gates and hoists.
- (11) Scientific, for scientific purposes and research or for education in science ;
- (12) Specialised hospital and surgical equipment, which in the opinion of the Board is imported for use only in connection with surgical and medical treatment ;
- (13) X-ray films and plates.

#### 28. MANURES and FERTILIZERS.

29. MARINE ENGINES being main propulsion or auxiliary machinery specifically constructed or adapted for marine use, other than outboard motors.

30. MEDICINAL PREPARATIONS, DRUGS, ANAESTHETICS and DRESSINGS included in the editions of the British Pharmacopoeia, the British Pharmaceutical Codex or the Veterinary Codex current at the time of importation (or the immediately previous edition of any such publication) and clearly labelled with the description shown therein. Provided that this exemption shall not apply to undiluted potable alcohol or potable alcohol diluted with water only.

31. METALLIFEROUS ORES of all kinds.

32. METERS, gas supply.

33. MINING MATERIALS, namely—

- (1) Barytes (barium sulphate) ;
- (2) Cyanides, imported on licence issued by the Chief Inspector of Mines ;
- (3) Gauze and screening, of metal or plastic, for mining machinery ;
- (4) Mineral flotation reagents certified as such by the Chief Inspector of Mines ;
- (5) Zinc dust, zinc ingots and zinc shavings.

34. MOTOR and STEAM stone crushers, road rollers, graders and scarifiers, road sweepers and sprayers, tractors and trailers therefor, and other mechanically propelled engines and machines not elsewhere specified or included in the Schedules to this Act, ordinarily employed in the construction and maintenance of roads or the clearing of land ; motor ambulances and mobile dispensaries.

35. NAVAL, MILITARY AND AIR FORCE STORES and other GOODS imported by Consular, Civil and Certain other officers as set out in this item (importation meaning also clearance from a bonded warehouse) namely :—

(1) ALL GOODS IMPORTED :

(a) OFFICIALLY :—

for the use of Nigeria Armed Forces.

(b) FOR THE OFFICIAL USE :—

(i) of a Consular Officer where the country he represents grants a like privilege to Nigerian Consular Officers ;

(ii) of the President of the Federal Republic of Nigeria, or of a Governor of a Region of Nigeria, or of any officer for the time being acting as the President of the Federal Republic of Nigeria or as the Governor of a Region, during such time as he is so acting.

(c) FOR THE PERSONAL USE :—

(i) of a Consular Officer (also for use of his family), where the Government of the country he represents grants a like privilege to Nigerian Consular Officers ;

(ii) of the President of the Federal Republic of Nigeria, or of a Governor of a Region of Nigeria or of any officer for the time being acting as the President of the Republic of Nigeria or as the Governor of a Region, during such time as he is so acting.

(2) ACCOUTREMENTS, EQUIPMENT AND UNIFORMS, the property of officers of Nigeria Armed Forces, imported by such officers for their PERSONAL USE ON DUTY as required by the regulations of their respective services.

(3) DIPLOMATIC PRIVILEGED IMPORTATIONS, namely, the furniture and effects (which expression shall include a motor vehicle) of any person, not being a native of Nigeria, who is an official of an organisation declared by notice in the *Federal Official Gazette* to be an organisation of which Her Majesty's Government in the United Kingdom and the Governments of one or more sovereign Powers are members, at the time that such person first takes up his post in Nigeria.

(4) TECHNICAL ASSISTANCE IMPORTATIONS :—

(a) All goods imported for the purpose of directly implementing any project arising within any scheme of technical assistance approved by the Government of the Federation by notice in the *Federal Official Gazette* ; and

(b) The furniture and effects (which expression shall include a motor vehicle and an air conditioner) of any person, at the time such person first takes up his post in Nigeria, who is in Nigeria under any such scheme of technical assistance.

Provided that :—

1. For the purpose of sub-item (1)(c) the expression "Consular Officer" :—

(i) means a Consular Officer *de Carriere* who is recognised as a Consular Officer by the Government of the country he represents and is a national of that country ; and

(ii) includes, in relation to any country which is declared by the President to be a country with the Government of which a convention making provision in that behalf has been concluded, a person who—

- (a) is employed by that Government at a Consulate otherwise than on domestic duties; and
- (b) is a national of that country; and
- (c) is not otherwise engaged in gainful occupation in Nigeria; and
- (d) if not a permanent employee of that Government, was not resident in Nigeria at the time when his employment at the Consulate began.

2. The provisions in sub-items (1) (b) (i) and (1) (c) (i) shall be deemed to have had effect from the date upon which any convention or agreement is entered into between the Government of the Federal Republic of Nigeria and the foreign Government concerned.

36. NAVIGATIONAL EQUIPMENT, namely :—

- (1) Buoys (all types), buoyage equipment, anchors, mooring, chain cable, quay bollards and capstans;
- (2) Diving gear and equipment, including air pumps and decompression chambers, diving suits, helmets and boots;
- (3) Specialised equipment for light houses and other navigational aids on land or water for ships or aircraft, including beacons, marks flares and radar equipment.

37. NEWSPRINT in reels or in the flat.

38. PACKING MATERIALS AND CONTAINERS :—

- (1) Banana Wrapping : clear polythene (diothene) endless tubing perforated both latitudinally and longitudinally having a minimum width of twenty inches and a maximum width of twenty-six inches;
- (2) Compressed gas cylinders, empty;

- (3) Containers, including boxes, tins, bottles, jars and other packages in which any goods not liable to an *ad valorem* duty and on which duty is not chargeable on gross weight are packed and imported, being ordinary trade packages for the goods contained therein.

39. PASSENGERS' BAGGAGE :—

- (1) Personal and household effects, the property of and accompanying a passenger, to the extent permitted by the Board, and subject to any conditions imposed by it;

- (2) Personal and household effects, the property of a passenger, landed at any customs port, customs airport or customs station within two months of the arrival of the passenger, or within such further period as the Board may allow, to the extent permitted by the Board and subject to any conditions imposed by it; and

- (3) The property of and accompanying a temporary visitor to Nigeria, to the extent permitted by the Minister and subject to any conditions imposed by him.

Provided that for the purpose of sub-items (1) and (2) "baggage" shall not be interpreted to include goods for sale, barter or exchange.

40. PATTERNS AND SAMPLES cut, mutilated, spoiled or otherwise rendered unmerchantable; articles which the Board is satisfied are not imported for trade purposes and which, in the opinion of the Board, are of no commercial value.

41. PERSONAL EFFECTS, not being merchandise, of a native of Nigeria dying in places outside the limits of the jurisdiction of Nigeria.

42. PICTURES AND PHOTOGRAPHS, UNFRAMED; DRAWINGS; ENGRAVINGS.

43. PREPARATIONS AND SUBSTANCES OF THE FOLLOWING KINDS; sprayers, sprinklers and other apparatus and appliances for use therewith:—

(1) animal dips, fungicides, insecticides, vermin killers; other similar substances which the Board is satisfied are exclusively for the prevention and cure of diseases in plants, trees, and animals other than human beings;

(2) Disinfectants;

(3) Germicides;

(4) Insect repellents;

(5) Weed killing preparations.

44. PRINTERS' INK, TYPE, TYPE METAL, PRINTING MACHINES, printing appliances (other than all paper, excepting spool paper); lithographic process cameras and unexposed lithographic sheet film of a speed slower than H & D 100, 16/10 DIN or 27 Scheiner.

45. Provisions of the following kinds:—

(1) African foodstuffs produced in any territory adjoining Nigeria;

(2) Fish, fresh, caught and landed by canoes or by vessels based in Nigeria;

(3) Milk or cream, whether fresh, concentrated or preserved in any way but not including sweetened milk or cream;

(4) Wheat and spelt (including meslin) unmilled.

46. RAILWAY construction and equipment requisities; locomotives and other rolling stock, rails, sleepers; fastenings for rails and sleepers, switch-boxes, signals, turn-tables and similar railway equipment, but not including material, imported by the Nigerian Railway Corporation.

47. SEEDS for planting; bulbs, tubers and rhizomes of flowering or foliage plants; cuttings, slips, live trees and other plants.

48. SOUND RECORDINGS containing spoken messages of a personal nature; language teaching records.

49. STEAM VESSELS, BARGES, BOATS, LAUNCHES and LIGHTERS of over 250 gross tons; where the Minister is satisfied that they cannot be built in Nigeria, steam vessels, barges, boats, launches and lighters not exceeding 250 gross tons, imported assembled, or in sections to be assembled, provided the Board is of the opinion that they are not of the type mainly used for pleasure. Provided further that when condemned or handed over to be broken up, duty shall be paid on the hull, parts and fittings according to the Customs Tariff that may then be in force.

50. Duplicators, models, gramophones, broadcast receivers (including television sets); artists' paints and equipment; chemicals for use in laboratories, prize medals or badges, boxing gloves, punch balls, rope gymnasium

mattresses, film strip projectors, epidiascopes, episcope and magic lanterns, where the Board is satisfied that they are imported by or on behalf of a school or educational establishment and are solely for educational purposes.

51. TELECOMMUNICATIONS and BROADCASTING APPARATUS and appliances, and component parts thereof (but not including material, except where specially provided for, and apparatus and appliances for domestic use or use on road vehicles), namely :—

- (1) Aerial antennae ;
- (2) Apparatus for measuring and controlling electric energy ;
- (3) Apparatus other than radio for telegraphy and telephony including that for automatic telephone and telegraph systems and mechanical transmitters and receivers for telegraphy ;
- (4) Controlling or measuring instruments, electrical, for controlling the flow, volume or depth of liquids or gases ;
- (5) Electric eye devices ;
- (6) Electric signalling and safety apparatus, electric bells ;
- (7) Electrical insulated conduit tubing ;
- (8) Electro-thermic apparatus for use in telecommunications and broadcasting systems ;
- (9) Fuse plugs, sockets, switches ;
- (10) Glass accumulators and storage batteries ;
- (11) Insulated cable and wire for electricity ;
- (12) Insulating and friction repair tape ;
- (13) Insulators, electric, for use in telecommunications and broadcasting equipment and fittings therefor ;
- (14) Permanent magnets ;
- (15) Radio apparatus for telegraphy, telephony and broadcasting ;
- (16) Sleeves, jointing, metal and paper for overhead and underground telegraph lines ;
- (17) Telegraph poles and radio masts, metal and fittings therefor ;
- (18) Teleprinter and wheatstone paper (morse tape) ;
- (19) Uninsulated copper wire ;
- (20) Wet primary cells.

52. TOMBSTONES and memorials engraved with a commemorative inscription to a deceased person.

53. Tyres and tubes with a cross-section of 12 inches or more, designed to fit wheel rims having a nominal measurement at the tyre seat of 20 inches or more, if in earthmover or grader patterns and so invoiced.

54. WATER FILTERS and parts thereof and all appliances for the filtration of water.

55. WIRELESS LOUDSPEAKER UNITS, with or without their associated cabinets, condensers, volume controls and volume control knobs imported for the sole purpose of radio programme distribution by wire.

56. WORKS OF ARTS, specimens and collectors' pieces of an educational, scientific or cultural character, namely :—

- (1) Antiques, being articles proved to the satisfaction of the Board to be over 100 years old ;

(2) Original works of art, collectors' pieces and objects of art, not intended for sale, barter or exchange, imported by, or consigned to, public galleries, museums and any other public institutions approved by the Board for public exhibition;

(3) Scientific specimens imported for public exhibition, study or research.

57. Goods imported by the following, where the Minister is satisfied that either—

(a) adequate arrangements have been made for their distribution free of charge within Nigeria to the poor and needy; or

(b) they are solely for the official use of the Head of the importer's establishment in Nigeria :—

(1) The Catholic Relief Services;

(2) The Church World Service.

### THIRD SCHEDULE

#### EXPORT DUTIES OF CUSTOMS

	£	s	d
1. ANIMALS, BIRDS, AND REPTILES, live, not for food :—			
(1) Animals, reptiles, and African grey parrots .. .. . each .. ..	3	0	0
(2) Birds, other .. .. . each .. ..	1	0	0
2. BANANA :—			
(1) Fresh .. .. . the count bunch	0	1	6
(2) Dry (except dry bananas which by reason of the manner in which they have been prepared or their condi- tion or otherwise the Board is satis- fied will not be used for human consumption) .. .. . the ten pounds ..		0	0 2

A "count bunch" of bananas means a stalk bearing nine or more hands of bananas, each hand being a cluster of bananas growing from the stalk and originally covered by a separate bract

For the purpose of the computa-  
tion of the duty a stalk bearing—

9 hands or over shall be taken to  
be equal to .. .. . 1 count bunch.

8 hands or over but less than  
9 hands shall be taken to be  
equal to .. .. .  $\frac{3}{4}$  of a count bunch.

7 hands or over but less than  
8 hands shall be taken to be  
equal to .. .. .  $\frac{1}{2}$  of a count bunch.

Under 7 hands shall be taken to  
be equal to .. .. .  $\frac{1}{4}$  of a count bunch.

- |                            |         |   |
|----------------------------|---------|---|
| 3. BENNISEED .. .. .       | .. .. . | 10 per centum <i>ad valorem</i> on the value calculated in accordance with the Valuation (Export Duties) Regulations, 1959.   |
| 4. CATTLE, live .. .. .    | .. .. . | per head .. .. . 3 0 0  |
| 5. COCOA BEANS .. .. .     | .. .. . | 10 per centum <i>ad valorem</i> when the value, calculated in accordance with the Valuation (Export Duties) Regulations, 1959, does not exceed £150 per ton with an additional one-tenth of 1 per centum for every £ or part of a £ by which the value, calculated as aforesaid, exceeds £150 per ton, provided that the amount of duty chargeable shall not exceed 20 per centum of the value calculated as aforesaid.   |
| 6. COTTON LINT .. .. .     | .. .. . | 10 per centum <i>ad valorem</i> when the value, calculated in accordance with the Valuation (Export Duties) Regulations, 1959, does not exceed £325 per ton, with an additional one-tenth of 1 per centum for every £ or part of a £ by which the value, calculated as aforesaid, exceeds £325 per ton, provided that the amount of duty chargeable shall not exceed 20 per centum of the value, calculated as aforesaid. |
| 7. COTTON SEED .. .. .     | .. .. . | 10 per centum <i>ad valorem</i> on the value calculated in accordance with the Valuation (Export Duties) Regulations, 1959.   |
| 8. GROUNDNUT .. .. .       | .. .. . | 10 per centum <i>ad valorem</i> on the value calculated in accordance with the Valuation (Export Duties) Regulations, 1959, does not exceed £65 per ton, with an additional one-tenth of 1 per centum for every £ or part of a £ by which the value, calculated as aforesaid, exceeds £65 per ton provided that the amount of duty chargeable shall not exceed 20 per centum of the value, calculated as aforesaid.       |
| 9. GROUNDNUT CAKE .. .. .  | .. .. . | } 10 per centum <i>ad valorem</i> on the value calculated in accordance with the Valuation (Export Duties) Regulations, 1959.   |
| 10. GROUNDNUT MEAL .. .. . | .. .. . |   |
| 11. GROUNDNUT OIL .. .. .  | .. .. . |   |

	£	s	d
12. HIDE, CATTLE :—			
(1) Dry :—			
undressed, dressed or tanned .. .. .	27	10	0
(2) Wet :—			
dressed or tanned .. .. the ton .. .. .	9	3	4
13. PALM KERNEL .. .. .	10 <i>per centum ad valorem</i> when the value, calculated in accordance with the Valuation (Export Duties) Regulations, 1959, does not exceed £50 per ton, with an additional one-tenth of 1 <i>per centum</i> for every £ or part of a £ by which the value, calculated as aforesaid, exceeds £50 per ton, provided that the amount of duty chargeable shall not exceed 20 <i>per centum</i> of the value, calculated as aforesaid.		
14. PALM KERNEL CAKE .. .. .	} 10 <i>per centum ad valorem</i> on the value calculated in accordance with the Valuation (Export Duties) Regulations, 1959.		
15. PALM KERNEL MEAL .. .. .			
16. PALM KERNEL OIL .. .. .			
17. PALM OIL :—			
(1) Edible .. .. .	10 <i>per centum ad valorem</i> when the value, calculated in accordance with the Valuation (Export Duties) Regulations, 1959, does not exceed £75 per ton, with an additional one-tenth of 1 <i>per centum</i> for every £ or part of a £ by which the value, calculated as aforesaid, exceeds £75 per ton provided that the amount of duty chargeable shall not exceed 20 <i>per centum</i> of the value, calculated as aforesaid.		
(2) Technical .. .. .	10 <i>per centum ad valorem</i> when the value, calculated in accordance with the Valuation (Export Duties) Regulations, 1959, does not exceed £65 per ton, with an additional one-tenth of 1 <i>per centum</i> for every £ or part of a £ by which the value, calculated as aforesaid exceeds £65 per ton, provided that the amount of duty chargeable shall not exceed 20 <i>per centum</i> of the value, calculated as aforesaid.		

18. RUBBER :—  
(1) Crepe

.. .. .

10 per centum ad valorem on the value calculated in accordance with the Valuation (Export Duties) Regulations, 1959, provided that—

- (a) no duty shall be chargeable when the value, calculated as aforesaid, is less than 18d per lb; and
- (b) the amount of duty chargeable shall not exceed and shall where appropriate be reduced to the excess of the value per lb., calculated as aforesaid, over 18d per lb.

(2) Paste

.. .. .

5 per centum ad valorem on the value calculated in accordance with the Valuation (Export Duties) Regulations, 1959: provided that—

- (a) no duty shall be chargeable when the value, calculated as aforesaid, is less than 18d per lb; and
- (b) the amount of duty chargeable shall not exceed and shall where appropriate be reduced to the excess of the value per lb; calculated as aforesaid, over 18d per lb.

(3) Raw—All Grades

.. .. .

10 per centum ad valorem on the value calculated in accordance with the Valuation (Export Duties) Regulations, 1959: provided that—

- (a) no duty shall be chargeable when the value calculated as aforesaid, is less than 18d per lb; and
- (b) the amount of duty chargeable shall not exceed and shall where appropriate be reduced to the excess of the value per lb, calculated as aforesaid over 18d per lb.

19. SHEA NUT

.. .. .

the ton

£ s d  
2 10 0

20. SKIN :—

.. .. .

the ton

6 5 0

(1) GOAT, Dressed or tanned

the ton

75 0 0

(2) GOAT, Undressed

		£	s	d
(3) SHEEP, Dressed or tanned	.. the ton	6	5	0
(4) SHEEP, Undressed	.. the ton	43	15	0
(5) REPTILE, dressed or undressed	.. the pound or part thereof	0	1	0
(6) FUR, dressed and undressed :—				
(a) Lesser cats	.. the pound or part thereof	0	1	6
(b) Other	.. the pound or part thereof	0	10	0
21. SLAG	.. .. .	<i>ad valorem 10 per centum.</i>		
22. WOOD and TIMBER—				
(1) Chlorophora excelsa (Iroko)	} the cubic foot }	Exported in log form	.. ..	0 0 4
(2) Entandrophragma angolense (Gedunohor)				
(3) Entandrophragma, all other species (Sapelewood, Omu)				
(4) Gossweilerodendron Balsamiferum (Agba)				
(5) Guarea all species (Guarea)				
(6) Khaya, all species (African mahogany, Lagoswood, Benin-wood)				
(7) Lova trichiloides (Apopo, Walnut)				
(8) Mansonia altissima (Mansonia)				
(9) Nauclea diderrichii (Opepe, Obiache)				
(10) Triplochiton scleroxylon (Obeche)				
(11) All other timbers not mentioned in the above Schedule sawn (including veneers but not including plywood) or log				
(12) Curls	.. .. the curl	.. ..	0 5 0	

Provided that where goods are officially exported for the use of members of Nigeria Armed Forces, they shall be exempt from duty.

MADE at Lagos this 3rd day of August, 1964.

R. C. ONYEJEPU,  
Acting Deputy Secretary to  
the Council of Ministers

#### EXPLANATORY NOTES

This Order has the effect of consolidating all previous amendments to the Schedules to the Customs Tariff Act, 1958, setting out the duties payable on imports, the list of goods exempt from payment of such duties, and the duties payable on exports.

It also has the following effects :—

FIRST SCHEDULE—IMPORT DUTIES

(a) Generally, it raises :—

- (1) the general *ad valorem* rate of 20 per centum to  $33\frac{1}{3}$  per centum.
- (2) *ad valorem* 10 per centum to 15 per centum.
- (3) *ad valorem* 25 per centum to  $33\frac{1}{3}$  per centum.
- (4) *ad valorem* 30 per centum to  $33\frac{1}{3}$  per centum.
- (5) *ad valorem*  $33\frac{1}{3}$  per centum to 40 per centum.
- (6) *ad valorem* 50 per centum to  $66\frac{2}{3}$  per centum.

(b) It raises :—

- (1) the general *ad valorem* duty of 20 per centum to  $66\frac{2}{3}$  per centum, on :—
  - (i) basketwork, wickerwork, loofah and articles made therefrom ;
  - (ii) flowers and foliage, whether natural or not, for decorative purposes.

(2) *ad valorem* 25 per centum to 40 per centum, on :—

- (i) office machinery, including typewriters, book-keeping and calculating machines, dictating machines and tape recorders, including parts therefor ;
- (ii) all foodstuffs and beverages not elsewhere specified or included in the First Schedule.

(3) *ad valorem*  $33\frac{1}{3}$  per centum to 50 per centum, on :—

- (i) broadcast receivers—sound and television ;
- (ii) carpets, carpeting, floor rugs, linoleum, mats, matting and tapestries ;
- (iii) chinaware and pottery, other than builders' fittings, suitable for hotel, household and restaurant use or for personal adornment ;
- (iv) cutlery including kitchen and table knives, forks and spoons, of base metal including plated ;
- (v) film (still), plates and paper unexposed, for photography ;
- (vi) films, cinematograph, all sizes commonly known as 8 mm. and 9.5 mm., unexposed ;
- (vii) metal office furniture and cabinets ;
- (viii) shot guns and air guns, including air rifles.

(4) *ad valorem* 50 per centum, to 75 per centum, on :—

- (i) bed mattresses ;
- (ii) table waters, including mineral waters of all descriptions.

(5) *ad valorem* 75 per centum to 100 per centum, on :—

- (i) jewellery including imitation jewellery and rolled gold, enamel or gilt jewellery, precious and semi-precious stones, pearls and imitations thereof ; goldsmiths' and silversmiths' wares ;
- (ii) passenger cars exceeding 3,500 c.c.

(6) from 1s-8d to 1s-9d the gallon, the duty on :—

- (i) gas and diesel oils for use by persons other than the Nigerian Coal Corporation, the Nigerian Railway Corporation, the Electricity Corporation of Nigeria, the Nigerian Electricity Supply Company and the Nigerian Ports Authority ;
- (ii) motor spirit.

c) It increases the alternative *ad valorem* rates on :—

- (1) Secondhand clothing from  $33\frac{1}{3}$  to 40 *per centum*.
- (2) blankets and rugs from  $33\frac{1}{3}$  to 50 *per centum*.
- (3) mechanical and similar lighters from  $33\frac{1}{3}$  to  $66\frac{2}{3}$  *per centum*.

d) It rationalises the various rates of duty on apparel and accessories for apparel and, amongst other things :—

- (1) fixes the rate of duty for children's shoes at  $33\frac{1}{3}$  *per centum ad valorem*.
- (2) raises all other alternative *ad valorem* rates from  $33\frac{1}{3}$  *per centum* to 40 *per centum*.

(3) increases the duty on :—

- (i) jackets, gents' trousers and ladies' slacks to 7s-6d each ;
- (ii) shirts, from 2s-6d to 5s each ;
- (iii) singlets, from 1s to 3s-6d each ;
- (iv) dressing gowns and skirts to 4s-6d.

e) It increases the import duty on :—

- (1) beer, from 9s-6d the gallon to 15s the gallon.
- (2) cider and perry, from 10s the gallon to 15s the gallon.
- (3) shoes :—
  - (a) made principally of canvas and rubber or of either from 4s the pair or *ad valorem*  $33\frac{1}{3}$  *per centum* to 6s the pair or 40 *per centum ad valorem* ;
  - (b) made of other materials from 7s-6d the pair or  $33\frac{1}{3}$  *per centum ad valorem* to 10s-6d the pair or 40 *per centum ad valorem*.
- (4) beads from 8d the pound gross or *ad valorem* 25 *per centum* to 1s the pound gross or *ad valorem* 40 *per centum*, whichever is the higher.
- (5) bicycles and tricycles, from £2 each or *ad valorem* 20 *per centum* to £3 each or *ad valorem*  $33\frac{1}{3}$  *per centum*, whichever is the higher.
- (6) cement clinker, from 10 *per centum ad valorem* to £1-15s the ton or *ad valorem* 20 *per centum*, whichever is the higher.
- (7) Portland cement and similar cements, from £2-10s the ton or *ad valorem*  $33\frac{1}{3}$  *per centum* to £5 the ton or *ad valorem* 75 *per centum*, whichever is the higher.
- (8) clocks and watches, from 1s-8d each or *ad valorem*  $33\frac{1}{3}$  *per centum* to 7s-6d each or 50 *per centum ad valorem*, whichever is the higher.
- (9) fireworks, from 5s to 10s the pound gross.
- (10) furniture including framed mirrors, ornaments, framed pictures and photographs and similar articles—other than metal office furniture and cabinets, and bed mattresses—from  $33\frac{1}{3}$  *per centum* to 75 *per centum ad valorem*.
- (11) lubricating grease, from  $1\frac{1}{2}d$  to 3d the pound.
- (12) gunpowder, from 5s to 7s-6d the pound.
- (13) hair pads, hair nets, wigs, false beards and similar articles, from 20 *per centum* to 100 *per centum ad valorem*.
- (14) hand implements, hand tools and parts thereof, from 10 *per centum* to 20 *per centum ad valorem*.
- (15) lime, from £2-5s to £3 the ton gross.
- (16) parts for mechanical and similar lighters from  $33\frac{1}{3}$  to  $66\frac{2}{3}$  *per centum ad valorem*.
- (17) matches, from £1-10s to £2-2s the gross boxes,

- (18) nails, barbed iron or steel wire, single flat wire and twisted barbed wire, from 20 *per centum ad valorem* to 2*d* the pound or 33½ *per centum ad valorem*.
- (19) gas and diesel oils for use by the Nigerian Railway Corporation, the Nigerian Coal Corporation, the Nigerian Electricity Supply Company, the Nigerian Ports Authority, from 2*d* to 4*d* the gallon.
- (20) oil, not elsewhere specified in the First Schedule, from 1*s*-3*d* the gallon or *ad valorem* 20 *per centum* to 1*s*-6*d* the gallon or *ad valorem* 33½ *per centum*, whichever is the higher.
- (21) paint, enamel, lacquers and varnishes from 20 *per centum ad valorem* to 10*d* the pound or 33½ *per centum ad valorem*.
- (22) toilet paper, from 20 *per centum* to 33½ *per centum ad valorem*.
- (23) other paper and paper manufactures, from 20 *per centum* to 25 *per centum ad valorem*.
- (24) piece goods :—
- (i) cotton fabrics, bleached and unbleached, from 1*s* the square yard or *ad valorem*, 25 *per centum* to 1*s*-3*d* the square yard or *ad valorem* 33½ *per centum*, whichever is the higher;
  - (ii) unbleached grey baft, imported by approved manufacturers, from 1.8*d* the square yard to 4.8*d* the square yard;
  - (iii) velvet, velveteen, plushes and other pile fabrics, from 3*s* the square yard to 4*s* the square yard;
  - (iv) other, from 1*s*-9*d* to 2*s* the square yard.
- (25) bakery products, other than biscuits, from 33½ *per centum* to 40 *per centum ad valorem*.
- (26) butter, cheese and edible fats of all kinds, from 1*s*-3*d* to 1*s*-6*d* the pound.
- (27) confectionery from 1*s* the pound or *ad valorem* 50 *per centum* to 1*s*-3*d* the pound or *ad valorem* 66⅔ *per centum*, whichever is the higher.
- (28) crustaceans, molluscs, caviar and caviar substitutes from 25 to 50 *per centum ad valorem*.
- (29) salt, from £3-13*s*-0*d* the ton to £4 the ton.
- (30) passenger cars exceeding 2,750 c.c. but not exceeding 3,500 c.c. from 66⅔ to 75 *per centum ad valorem*.
- (31) motor buses and coaches with fitted seats for 20 or more passengers—*assembled*—from 5 *per centum* to 10 *per centum ad valorem*.
- (32) corrugated sheets of galvanised iron or aluminium, from 1*d* the square foot to 1½*d* the square foot;
- (33) rubber fabricated material for tyre re-treading from 10 to 33½ *per centum ad valorem*.
- (34) smoking pipes, cigarettes and cigarette holders and similar articles, and parts therefor, from 20 *per centum* to 50 *per centum ad valorem*.
- (35) caustic soda, other than for approved manufacturers, from £1-15*s*-0*d* to £2 the hundred weight.

- (36) steam vessels, barges, boats, launches and lighters not exceeding 250 gross ton :—
- (a) pleasure craft, touring launches and commercial craft of a range not exceeding 100 feet in length from 10 to 50 *per centum ad valorem* ;
  - (b) other—except where the Minister is satisfied that they cannot be built locally, from 10 to 33½ *per centum ad valorem* ;
  - (c) fittings, spare parts, etc., imported by an approved user, from 10 to 20 *per centum ad valorem* ;
- (37) synthetic perfume materials and concentrates, and enfleurage greases—not for approved manufacturers—from 30 *per centum* to 100 *per centum ad valorem*.
- (38) made-up textile articles, whether or not impregnated or coated, from 20 *per centum* to 40 *per centum ad valorem*.
- (39) cigarettes, from £2-8s-0d the pound or £6-5s-0d the thousand cigarettes to £2-15s-0d the pound or £6-15s-0d the thousand cigarettes, whichever is the higher.
- (40) manufactured tobacco, other than cigars and cigarettes, from £1-16s-0d to £2 the pound.
- (41) unmanufactured tobacco—not for licensed manufacturers, from 15s to £1 the pound.
- (42) travelling trunks, travel bags, hand bags, portmanteaux, purses, suit cases and wallets, imported nested, from 4s each or *ad valorem* 33½ *per centum*, whichever is the higher to 6s each or *ad valorem* 40 *per centum* whichever is the higher.
- (43) umbrellas and parasols, from 4s each or *ad valorem* 33½ *per centum*, whichever is the higher to 5s each or *ad valorem* 40 *per centum*, whichever is the higher.
- (44) umbrella covers, from 1s-8d each or *ad valorem* 33½ *per centum*, whichever is the higher to 2s or *ad valorem* 40 *per centum* whichever is the higher.
- (45) base metal single strand wire, uncoated—not for approved manufacturers—from 10 *per centum* to 33½ *per centum ad valorem*.
- (f) It alters the duty rating for cigars from £2-5s the hundred to £2-15s the pound.
- (g) It reduces the import duty on chocolate confectionery from 25 to 12½ *per centum ad valorem*.

#### SECOND SCHEDULE—EXEMPTIONS FROM IMPORT DUTIES

- (a) It abolishes the exemption (from payment of duty) for :—
- (1) warm clothing imported shortly before embarkation for the personal use of the importer abroad ;
  - (2) coal and coke ;
  - (3) parts of machinery, apparatus and appliances for use for the generation, measurement, transformation, storage, transmission, distribution of, or lighting by, electric power.
  - (4) parts and accessories of machinery for industrial, horticultural, agricultural etc., purposes.

- (5) parts for main propulsion and auxiliary machinery for marine use.  
 (6) framed pictures and photographs.  
 (7) mosquito nets.  
 (8) accoutrements, equipment and uniforms for personal use on duty by judges and officers of the Nigerian Civil Service.
- (b) It exempts from import duty :—  
 (1) goods imported by a contractor in respect of a contract, with Government, which provides for such exemptions.  
 (2) goods of a charitable nature, and gifts, approved by the Minister.

THIRD SCHEDULE—EXPORT DUTIES

It reduces the export duty on dressed and undressed furs of lesser cats from 10s to 1s-6d the pound or part thereof.  
 It imposes an export duty at 10 per centum *ad valorem* on Slag.

L.N. 92 of 1964

EXCISE TARIFF ACT, 1958  
 (No. 58 OF 1958)

Excise Tariff (Duties) (No. 2) Order, 1964

Commencement : 3rd August, 1964

In exercise of the powers conferred by subsection (1) of section 3 of the Excise Tariff Act, 1958, the President hereby makes the following Order—

1. This Order may be cited as the Excise Tariff (Duties) (No. 2) Order, 1964, and shall apply throughout the Federation.
2. The Schedule to the Excise Tariff Act, 1958, as amended from time to time, is revoked and replaced by the following Schedule.

Short title and application.

Replacement of Schedule to the Act.

SCHEDULE

GOODS LIABLE TO EXCISE DUTY

		£	s	d
1. APPAREL :—				
(1) Shirts	.. .. .	0	0	9
(2) Singlets	.. .. .	0	0	6
2. BEER—other than native liquor	.. the gallon of worts of a specific gravity of not more than 1,040° for each additional degree of specific gravity ..	0	7	0
		0	0	0½

3. \*BISCUIT .. .. . 5 per centum of the selling price.
4. \*BLANKET .. .. . 5 per centum of the selling price.
5. CEMENT .. .. . the ton .. .. . 0 15 0
6. †CIGARETTES :—
- (1) where the weight of one thousand cigarettes does not exceed two pounds .. .. . 30 per centum of the selling price.
- (2) where the weight of one thousand cigarettes exceeds two pounds but does not exceed two and one-half pounds .. .. . 48 per centum of the selling price where the selling price exceeds seventy shillings per thousand, and 40 per centum of the selling price in other cases.
- (3) where the weight of one thousand cigarettes exceeds two and one-half pounds .. .. . 50 per centum of the selling price.
7. CONFECTIONERY, SUGAR, namely toffees, boiled sweets (commonly so called), pastilles, humbugs, and the like, including chocolate confectionery but excluding bakers' confectionery .. the pound .. .. . 0 0 3
8. \*CORNERD BEEF .. .. . 5 per centum of the selling price.
9. \*ENAMELWARE .. .. . 5 per centum of the selling price.
10. FOOTWEAR :—
- (1) Wholly or mainly of leather .. the pair .. .. . 0 3 0
- (2) Of other material .. .. . the pair .. .. . 0 1 0
11. LEMONADE AND OTHER AERATED WATERS, whether flavoured or not .. the gallon .. .. . 0 0 8
12. MATCHES :—
- In boxes containing 80 matches each or less .. .. . the gross boxes .. .. . 0 12 0
- For the purpose of this item, four "booklets" of matches shall be regarded as a box.
- Matches in boxes containing a greater quantity than 80 matches each to be charged in proportion.
13. NAILS, BARBED IRON OR STEEL WIRE, SINGLE FLAT WIRE, BARBED OR NOT, AND LOOSELY TWISTED BARBED WIRE of the kind used for fencing, of iron or steel; netting, fencing, reinforcing fabric and similar materials of iron or steel wire .. .. . the pound .. .. . 0 0 0½

14. PAINT, enamel, lacquers and varnishes .. .. .
15. PIECE GOODS :— .. the pound .. £ s d
- (1) Knitted fabric .. .. .
- (2) Cotton fabric, bleached and un-bleached .. .. . the pound .. 0 0 3
- (3) Other .. .. . the sq. yd. .. 0 0 2
16. \*PLASTICWARE .. .. . the sq. yd. .. 0 0 6
17. \*SOAP AND SOAP PRODUCTS .. .. . 5 per centum of the selling price.
18. SPIRITS, POTABLE .. .. . 5 per centum of the selling price.
19. \*TOWEL AND TOWELLING .. .. . the gallon .. 7 0 0
20. TRAVELLING TRUNKS, travel bags, handbags, portmanteaux, purses, suit-cases and wallets of all materials .. .. . 5 per centum of the selling price.
21. \*TYRES, PNEUMATIC of a sectional width exceeding 4" (101 mm.) but less than 12" (305 mm.) and tubes and flaps therefor .. each .. .. 0 1 0
22. \*YARNS AND THREADS .. .. . 10 per centum of the selling price.
- .. .. . 10 per centum of the selling price.

† For the purpose of Item 6 the expression "selling price" in relation to any cigarette means :—

- (a) the price declared by the manufacturer to be the price, inclusive of excise duty, at which cigarettes of the same brand, weight, quality and description are ordinarily sold by him ex-factory ; or
- (b) if it appears to the Board that the price so declared is less than the cost of manufacture of the cigarettes together with the excise duty thereon, and all profits taken or to be taken by the manufacturer in respect thereof, then a sum which, in the opinion of the Board, is equal to such cost together with such excise duty and profits.

\* For the purpose of those Items (other than Item 6) where the duty is expressed as a percentage of the selling price, the expression "selling price" means :—

- (a) the price declared by the manufacturer to be the price, exclusive of excise duty and before deduction of trade discounts, at which the goods liable to duty are ordinarily sold by him ex-factory ; or
- (b) if it appears to the Board that the price so declared is less than the cost of manufacture of the goods and all profits taken or to be taken by the manufacturer in respect thereof, a sum which in the opinion of the Board is equal to such cost together with such profits.

MADE at Lagos this 3rd day of August, 1964.

R. C. ONYEJUPU,  
Acting Deputy Secretary to  
the Council of Ministers

## EXPLANATORY NOTES

This Order has the effect of consolidating all previous amendments to the Schedule to the Excise Tariff Act, 1958.

It also has the following effects :—

- (a) It imposes excise duty on the following goods, manufactured in Nigeria :—
- (1) shirts at 9d each.
  - (2) singlets at 6d each.
  - (3) sugar confectionery, excluding bakers' confectionery, at 3d the pound.
  - (4) nails, barbed iron of steel wire, single flat wire—whether barbed or not—and loosely twisted barbed wire, at  $\frac{1}{2}$ d the pound.
  - (5) paint, enamel lacquers and varnishes, at 2d the pound.
  - (6) towel and towelling at 5 *per centum ad valorem*.
  - (7) travelling trunks, travel bags, handbags, portmanteaux, purses, suit cases and wallets of all materials at 1s each.
- (b) It increases the excise duty on :—
- (1) footwear :—
    - (i) made wholly or mainly of leather, from 2s to 3s the pair ;
    - (ii) made of other materials, from 6d to 1s the pair.
  - (2) matches, from 6s-9d to 10s the gross boxes.

L.N. 93 of 1964

MERCHANT SHIPPING ACT, 1962

Merchant Shipping (Medical Scales) Regulations, 1964

Commencement : (By notice)

In exercise of the powers conferred by sections 97 and 427 of the Merchant Shipping Act, 1962, the Federal Minister of Transport hereby makes the following regulations—

1. These regulations may be cited as the Merchant Shipping (Medical Scales) Regulations, 1964 and shall apply to every Nigerian ship, whose registered tonnage is above 15 tons, except pleasure yachts.

Short title and extent.

2. Every ship to which these regulations apply shall carry medicines and medical stores in accordance with the provisions of the scales set out in the Schedule to these regulations.

Ships to carry medicines and medical stores.

3. The application of the individual scales to particular classes of these ships is as follows.

Application.

Scale I applies to all ships which are required by law to carry a doctor.

Scale II applies to ships which are not required to carry a doctor and are ships of Class I or Class V.

Scale III applies to ships which are not required to carry a doctor and are ships of Class II or Class VI.

Scale IV applies to ships of Class III or Class VII.

Scale V applies to ships of Class IV or Class VIII and sea-going fishing vessels.

4. Instruments and appliances carried on board a ship, which but for the coming into operation of these regulations, would have been appropriate to the ship, need not be replaced so long as they remain in good serviceable condition. All renewals or replacements of such instruments and appliances however, shall comply with the scales set out in the said schedule.

Instruments and appliances already on board.

5. All poisons shall be kept in a separate cabinet under lock and key and, in the case of ships to which Scales II and III of the said schedule apply, responsibility for their safe custody shall rest with the Master of the ship.

Storage of poisons.

6. All orders for the supply of morphine ampoules and tablets for ships to which Scales II and III of the said schedule apply, shall be signed by the Master of the ship himself and not by a deputy.

Orders for morphine.

7. Masters of ships to which these regulations apply shall ensure that any medicines or medical stores used during a voyage are replaced at the first opportunity. When there is a general replenishment of medicines or medical stores, the Master of the ship shall procure from the chemist supplying such medicines or medical stores, a certificate to the effect that the ship's medical cabinet is in proper order in accordance with the scale applicable to that ship.

Replenishment of supplies.

8. Disinfectants and antiseptics must be of a brand complying with the specifications laid down in the Appendix to the Schedule.

Disinfectants and Antiseptics

9. The Government Inspector of Shipping may exempt any ship from the requirements of these regulations in so far as he is satisfied that compliance therewith would be unreasonable or impracticable in the circumstances, and that satisfactory alternative arrangements have been provided for the medical care of the crew and other persons on board.

Exemption to the requirements of the regulations

...dresses, and dressings set out in this  
...50 days' duration or less.  
...dresses' duration the quantities  
...for every additional period of

...and dresses shown in this  
...exceeding 1,000 shall be  
...additional 500 passengers  
...indicated by the symbol "\*".

...applies set out in this Scale  
...of the number of persons carried,  
...Scale.

...standards and requirements of the current  
...the British Pharmaceutical Codex or  
...those standards and requirements are  
...with any special requirements indicated

...shall be plainly and durably  
...of the contents as set out  
...where the use of such abbreviation  
...the Latin title in full;

...the supplier, which shall be indicated  
...not more than 25 per cent of  
...shall occupy

...shall be rendered resistant to moisture either by the use of an  
...which shall cover the label and overlap the edges, or  
...the effect of which is not inferior to varnishing.

...shall be indicated thus "p" shall be  
...printed thereon in capital  
...on a red background.

(5) Articles marked "4" shall be carried in green or amber-coloured  
...labelled "For external use only".

## SCALE I.—MEDICINES

Article <i>All drugs and materials must conform to the instructions preceding this scale</i>	Quantities for ships carrying passengers and crew not exceeding :—			
	250	500	750	1,000
*Acid. Boric. Cryst. . . . .	8 oz.	8 oz.	8 oz.	8 oz.
Acid. Hydrochlor. Dil. . . . .	1 fl. oz.	2 fl. oz.	3 fl. oz.	4 fl. oz.
*Acid. Salicyl. . . . .	$\frac{1}{2}$ oz.	$\frac{1}{2}$ oz.	$\frac{1}{2}$ oz.	$\frac{1}{2}$ oz.
*Acid. Sulph. Dil. . . . .	2 fl. oz.	2 fl. oz.	2 fl. oz.	2 fl. oz.
*Aether. Anaesth. (in amber coloured ampoules or in Tins) . . . . .	20 oz.	20 oz.	40 oz.	40 oz.
Aether. Solv. (not for Anaesthesia)	4 fl. oz.	8 fl. oz.	12 fl. oz.	16 fl. oz.
*Aethyl. Chor. 50 gramme tubes (for local spray anaesthesia) . . . . .	2 tubes	2 tubes	2 tubes	2 tubes
Ammon. Bicarb. . . . .	1 oz.	2 oz.	3 oz.	4 oz.
(a)*Antitox. Diphtheric. To be supplied in concentrated form containing not less than 4,000 units per ml.	20,000 units	40,000 units	60,000 units	80,000 units
*Antitox. Tetanus (1,500 International Units)	3 amps.	3 amps.	3 amps.	3 amps.
*Applicat. Benzyl. Benz. . . . .	1 pint	2 pints	3 pints	4 pints
Aq. pro. Inj. in 2 ml. ampoules . . . . .	12 amps.	24 amps.	36 amps.	48 amps.
*Argent. Nit. Indur. (mounted) . . . . .	2 pencils	2 pencils	2 pencils	2 pencils
Calamin. . . . .	2 oz.	4 oz.	6 oz.	8 oz.
*Caps. Chloramphen. 0.25 gm. . . . .	120 caps.	240 caps.	360 caps.	480 caps.
Cataplasm. Kaolin. (in $\frac{1}{2}$ lb. sealed tins)	3 tins	6 tins	9 tins	12 tins
Caps Tetracycline 250 mg. (or its equivalent broad spectrum antibiotic (b)) . . . . .	32	32	48	64
*Chlorof. (in amber coloured 2 oz. ampoules)	3 amps.	6 amps.	9 amps.	12 amps.
*Collod. Flex. (meth)... . . . .	4 fl. oz.	4 fl. oz.	4 fl. oz.	4 fl. oz.
Consper. Zinc. Oxid. et Amyli Co.	4 oz.	8 oz.	12 oz.	1 lb.
Consper. Zinc. Undecen. . . . .	8 oz.	16 oz.	24 oz.	32 oz.
*Dextros. Hyd. . . . .	1 lb.	1 lb.	1 lb.	1 lb.
Emuls. Menth. Pip. . . . .	1 fl. oz.	2 fl. oz.	3 fl. oz.	4 fl. oz.
Ext. Glycyrrh. Liq. . . . .	2 fl. oz.	4 fl. oz.	6 fl. oz.	8 fl. oz.
Ferr. et Ammon. Cit. . . . .	2 oz.	4 oz.	6 oz.	8 oz.
Glycer. . . . .	8 oz.	1 lb.	1 $\frac{1}{2}$ lb.	2 lb.
Glycer. Acid. Tann. . . . .	1 oz.	2 oz.	3 oz.	4 oz.
* <i>(b)</i> Gutt. Cocain. et Hydrarg. Perchlor. Oleos. . . . .	1 fl. oz.	1 fl. oz.	1 fl. oz.	1 fl. oz.
Gutt. Sulphacetamid. Mitis (c) . . . . .	1 fl. oz.	1 fl. oz.	1 fl. oz.	1 fl. oz.
*Inj. Adrenal. in 0.5 ml. amps. . . . .	3 amps.	6 amps.	9 amps.	12 amps.
*Inj. Apomorph. Hydrochlor. 1/20 gr. in 15 min. ampoules . . . . .	6 amps.	6 amps.	6 amps.	6 amps.

SCALE I.—MEDICINES—*continued*

Article <i>All drugs and materials must conform to the instructions preceding this scale</i>	Quantities for ships carrying passengers and crew not exceeding :—			
	250	500	750	1,000
Inj. Atrop. Sulph. 1/100 gr. in 1 ml.	6 amps.	12 amps.	18 amps.	24 amps.
*(f) Inj. Bemegride (in 10 ml. vials) or its equivalent	12 vials	12 vials	12 vials	24 vials
*Inj. Bism. (in 1 ml. ampoules)	6 amps.	6 amps.	6 amps.	6 amps.
*Inj. Emet. Hydrochlor. 1 gr. in 1 ml.	12 amps.	12 amps.	24 amps.	24 amps.
Inj. Ergomet. Maleat. 0.5 mg. in 1 ml.	3 amps.	6 amps.	9 amps.	12 amps.
Inj. Hyoscin. Hydrobrom. 1/100 gr. in 1 ml.	3 amps.	6 amps.	9 amps.	12 amps.
*(a) Inj. Insulin. (in 5 ml. vials of 40 units per ml.)	4 vials	6 vials	8 vials	12 vials
*Inj. Mersalyl. (in 1 ml. amps.)	6 amps.	6 amps.	6 amps.	6 amps.
*Inj. Morph. Sulph. $\frac{1}{4}$ gr. in 1 ml.	18 amps.	24 amps.	36 amps.	48 amps.
Inj. Nikethand. (in 2 ml. ampoules)	6 amps.	12 amps.	18 amps.	24 amps.
*(f) Inj. Pituit. Post. (in 1 ml. ampoules).	6 amps.	6 amps.	6 amps.	6 amps.
*Inj. Paraldehyd. (in 10 ml. ampoules)	3 amps.	3 amps.	3 amps.	3 amps.
*Inj. Procaïn. containing 2% W/V of Procaïn. Hydrochlor. (in 2 ml. ampoules)	6 amps.	12 amps.	18 amps.	24 amps.
*Inj. Procaïn. et Adrenal. Fort. (in 2 ml. ampoules)	6 amps.	12 amps.	18 amps.	24 amps.
Inj. Quinin. Dihydrochlor. (5 gr. in 5 ml. of solution, in ampoules)	3 amps.	6 amps.	9 amps.	12 amps.
Kaolin. Lev. . . . .	2 oz.	4 oz.	6 oz.	8 oz.

(a) To be kept constantly at a temperature not less than 34° F. or higher than 50° F. The date after which the anti-toxin is not to be used shall be stated on the label.

(b) To be supplied in bottle with dropper attached and with the following instructions on the label:—With the aid of the dropper put two drops into the eye every five minutes until the eye is insensitive. Usually three or four doses suffice. The eye should then be ready, and the foreign body can be removed with a previously sterilised eye spud. Afterwards an eye shade should be used for 24 hours.

(c) Store in a cool place and protect from light.

(d) To be kept constantly at a temperature not less than 34° F. or higher than 50° F. Not to be used more than 2 years after the date of manufacture as stated on the label.

(e) To be kept in cold store and to be renewed within 18 months of date of manufacture on the label.

(f) Alternative drug or continuation of drugs with similar therapeutic effect.

## SCALE I.—MEDICINES—continued

Article <i>All drugs and materials must conform to the instructions preceding this scale</i>	Quantities for ships carrying passengers and crew not exceeding :—			
	250	500	750	1,000
*†Lamell. Atrop. 1/5000 gr. (tubes of 20)	2 tubes	2 tubes	2 tubes	2 tubes
*†pLamell. Cocain. 1/50 gr. (tubes of 20)	2 tubes	2 tubes	2 tubes	2 tubes
*Lamell. Fluoresc. Sod. 1/1000 gr. (tubes of 20)	1 tube	1 tube	1 tube	1 tube
*†Lamell. Physostig. 1/1000 gr. (tubes of 20)	2 tubes	2 tubes	2 tubes	2 tubes
*Linct. Scill. Opiat. . . . .	1 pint	2 pints	3 pints	4 pints
†Lin. Methyl. Salicyl. . . . .	4 fl. oz.	8 fl. oz.	12 fl. oz.	16 fl. oz.
†Lin. Terebinth. . . . .	$\frac{1}{2}$ pint	1 pint	$1\frac{1}{2}$ pints	2 pints
*†Lamell. Adrenal. Hydrochlor. (in amber coloured bottle)	1 fl. oz.	1 fl. oz.	1 fl. oz.	1 fl. oz.
Liq. Ammon. Acet. Fort. . . . .	2 fl. oz.	4 fl. oz.	6 fl. oz.	8 fl. oz.
Liq. Ferr. Perchlor. . . . .	1 fl. oz.	2 fl. oz.	3 fl. oz.	4 fl. oz.
(b) Liq. Hydrog. Perox. (10 volumes). (To be supplied in 4 oz. amber coloured bottles)	1 bot.	2 bots.	3 bots.	4 bots.
Liq. Iod. Mit. . . . .	4 fl. oz.	8 fl. oz.	12 fl. oz.	16 fl. oz.
Liq. Morph. Hydrochlor. . . . .	1 fl. oz.	2 fl. oz.	3 fl. oz.	4 fl. oz.
Liq. Pic. Carbon. . . . .	1 fl. oz.	2 fl. oz.	3 fl. oz.	4 fl. oz.
†Liq. Plumb. Subacet. Fort. . . . .	1 pint	2 pints	3 pints	4 pints
Lot. Calamin. . . . .	1 oz.	2 oz.	3 oz.	4 oz.
Mag. Carb. Lev. . . . .	4 oz.	8 oz.	12 oz.	1 lb.
Mag. Carb. Pond. . . . .	4 lb.	8 lb.	12 lb.	16 lb.
Mag. Sulph. (in 1 oz. pkts.) . . . . .	8 oz.	1 lb.	$1\frac{1}{2}$ lb.	2 lb.
Mag. Trisil. . . . .	$\frac{1}{2}$ gall.	1 gall.	$1\frac{1}{2}$ gall.	2 gall.
*Mist. Senn. Co. . . . .	3 tubes	6 tubes	9 tubes	12 tubes
Oculent. Hydrarg. Oxid. in 60 gr. collapsible tube	$\frac{1}{2}$ pint	1 pint	$1\frac{1}{2}$ pints	2 pints
Ol. Arach. . . . .	1 pint	2 pints	3 pints	4 pints
Ol. Ricin. . . . .	3 fl. oz.	3 fl. oz.	3 fl. oz.	3 fl. oz.
*Ol. Terebinth. . . . .	$\frac{1}{2}$ pint	1 pint	$1\frac{1}{2}$ pints	2 pints
Paraff. Liq. . . . .	1 lb.	2 lb.	3 lb.	4 lb.
Paraff. Moll. Flav. . . . .	2 fl. oz.	4 fl. oz.	6 fl. oz.	8 fl. oz.
(c) (b) Paraldehyd. (in amber coloured bottle)	1 fl. oz.	2 fl. oz.	3 fl. oz.	4 fl. oz.
Phenol. Liq. . . . .	$\frac{1}{2}$ gross	1 gross	$1\frac{1}{2}$ gross	2 gross
Pil. Phenolphthal. Co. . . . .	4 oz.	8 oz.	12 oz.	1 lb.
Pot. Bicarb. . . . .	4 oz.	8 oz.	12 oz.	1 lb.
Pot. Brom. . . . .	4 oz.	8 oz.	12 oz.	1 lb.
Pot. Cit. . . . .	1 oz.	2 oz.	3 oz.	4 oz.
Pot. Iod. . . . .				

(a) To be kept constantly at a temperature not less than 34° F. or higher than 50° F.

(b) To be kept in a cool place.

(c) To be replaced within 12 months of the date of issue shown on the label.

Article <i>All drugs and materials must conform to the instructions preceding this scale</i>	Quantities for ships carrying passengers and crew not exceeding :—			
	250	500	750	1,000
(a) Procaine Penicillin G Fortified in rubber-capped vials each containing sterile procaine penicillin G300,000 international units and a crystalline penicillin salt 100,000 international units, or its equivalent injectable penicillin with suitable suspending and buffering agents. (e)	12 vials	24 vials	36 vials	48 vials
Pulv. Mag. Trisil. Co. . . . .	4 oz.	8 oz.	12 oz.	1 lb.
*Res. Carbol. . . . .	1 oz.	1 oz.	1 oz.	1 oz.
Sod. Bicarb. . . . .	1½ lb.	3 lb.	4½ lb.	6 lb.
Sod. Cit. . . . .	4 oz.	8 oz.	12 oz.	1 lb.
Sod. Salicyl. (in flake) . . . . .	4 oz.	8 oz.	12 oz.	1 lb.
(b) Solv. Pot. Permang. 8½ gr. . . . .	50	100	150	200
Solv. Sod. Chlorid. 15.75 gr. . . . .	100	200	300	400
Solv. Thymol. Co. . . . .	25	50	75	100
Sp. Ammon. Aromat. . . . .	4 fl. oz.	8 fl. oz.	12 fl. oz.	16 fl. oz.
Sp. Chir. (B.P.C. No. 1) . . . . .	½ pint	1 pint	1½ pints	2 pints
Sp. Chlorof. . . . .	2 fl. oz.	4 fl. oz.	6 fl. oz.	8 fl. oz.
*Sp. Rectificatus . . . . .	4 fl. oz.	4 fl. oz.	4 fl. oz.	4 fl. oz.
Streptomycin Sulphate (B.P.), equivalent to 1 Gramme Streptomycin base, in sealed container, with suitable suspending agents (a)	10 vials	15 vials	20 vials	30 vials
Sulphacetamid. Sod. . . . .	1 oz.	1 oz.	1 oz.	1 oz.
(c) Supp. Bism. Subgall. Co. . . . .	1 doz.	1 doz.	1 doz.	1 doz.
Syr. Chloral. . . . .	2 fl. oz.	4 fl. oz.	6 fl. oz.	8 fl. oz.
Syr. Tolu. . . . .	4 fl. oz.	8 fl. oz.	12 fl. oz.	16 fl. oz.
Tab. Acid. Acetylsalicyl. 5 gr. . . . .	100	200	300	400
*Tab. Butobarbiton. 1½ gr. . . . .	50	100	150	200
Tab. Casc. Sagr. 2 gr. . . . .	50	100	150	200
*Tab. Chloroquin. Phosphat. 0.25 gramme or Tab. Chloroquin. Sulphat. 0.25 gramme . . . . .	100	200	300	400
Tab. Codein. Co. . . . .	100	200	300	400
*Tab. Colchicin. 1/240 gr. . . . .	25	50	75	100
Tab. Digoxin. 0.25 mg. . . . .	25	50	75	100
Tab. Ephed. Hydrochlor. ½ gr. . . . .	25	50	75	100
Tab. Ergometrin. Maleat. 0.5 mg. . . . .	25	50	75	100
Tab. Ferr. Sulph. Exsic. 3 gr. . . . .	50	100	150	200
(d) Tab. Glyc. Trinit. 1/130 gr. . . . .	25	25	25	25
*Tab. Hydrarg.c. Cret. 1 gr. . . . .	100	100	100	100
Tab. Hydrarg. Subchlor. 1 gr. . . . .	25	50	75	100

(a) Label to state the volume of sterile solvent to be added to the vial for the preparation of a suspension for intramuscular injection, and to bear the words "to be kept in a cool dry place and renewed two years from the date of manufacture."

(b) The label to bear the words "One solution-tablet dissolved in 1 pint of water forms a 1 in 1,000 solution of potassium permanganate."

(c) To be kept in a cool place.

(d) To be kept in a well-closed container in a cool place and protected from light.

Article <i>All drugs and materials must conform to the instructions preceding this scale</i>	Quantities for ships carrying passengers and crew not exceeding :—			
	250	500	750	1,000
Tab. Hydrarg. Subchlor. $\frac{1}{2}$ gr. . . . .	50	100	150	200
*Tab. Hyoscin. Hydrobrom. $\frac{1}{200}$ gr. . . . .	50	100	150	200
Tab. Ipecac. et Opii 5 gr. . . . .	50	100	150	200
Tab. or Caps phenoxymethyl Penicillin 250 mg. (or its equivalent (c)) oral Penicillin . . . . .	50	100	150	200
*Tab. Mepyramin. Maleat. 0.1 gramme or . . . . .	50	100	150	200
Tab. Promethazin. Hydrochlor. 0.025 gramme (Histamine Antagonists) . . . . .	50	100	150	200
* <sup>p</sup> Tab. Morph. Hydrochlor. $\frac{1}{4}$ gr. or . . . . .	25	25	25	25
Tab. Morph. Sulph. $\frac{1}{4}$ gr. . . . .	50	100	150	200
Tab. Phenacet. et Caffein. . . . .	100	200	300	400
Tab. Phenobarbiton. $\frac{1}{2}$ gr. . . . .	50	100	150	200
Tab. Pot. Chlorat. 5 gr. . . . .	100	200	300	400
(a) Tab. Proguanil. Hydrochlor. 0.1 gramme. . . . .	100	200	300	400
Tab. Reserpin. 0.25 mg. (or its equivalent (c)). (d) . . . . .	50	100	150	200
Tab. Sod. Bicarb. Co. . . . .	100	200	300	400
Tab. Sod. Chlorid. 7 gr. with Dextros. 3 gr. . . . .	5,000	5,000	5,000	5,000
Tab. Stiboestr. 0.5 mg. (or its equivalent (c)) . . . . .	25	50	75	100
Tab. Sulphadimidin. 0.5 gramme (or its equivalent (b)) . . . . .	500	1,000	1,500	2,000
Tab. Sulphaguanidin. 0.5 gramme (or its equivalent (b)) . . . . .	250	500	750	1,000
Tab. Thyroid. $\frac{1}{2}$ gr. . . . .	25	50	75	100
*Tinct. Bellad. . . . .	2 fl. oz.	4 fl. oz.	6 fl. oz.	8 fl. oz.
Tinct. Benzoin. Co. . . . .	2 fl. oz.	4 fl. oz.	6 fl. oz.	8 fl. oz.
Tinct. Cardam. Co. . . . .	2 fl. oz.	4 fl. oz.	6 fl. oz.	8 fl. oz.
Tinct. Chlorof. et Morph. . . . .	2 fl. oz.	4 fl. oz.	6 fl. oz.	8 fl. oz.
Tinct. Gent. Co. . . . .	4 fl. oz.	8 fl. oz.	12 fl. oz.	16 fl. oz.
Tinct. Hyoscy. . . . .	2 fl. oz.	4 fl. oz.	6 fl. oz.	8 fl. oz.
Tinct. Ipecac. . . . .	4 fl. oz.	8 fl. oz.	12 fl. oz.	16 fl. oz.
Tinct. Nuc. Vom. . . . .	2 fl. oz.	4 fl. oz.	6 fl. oz.	8 fl. oz.
<sup>p</sup> Tinct. Opii . . . . .	2 fl. oz.	4 fl. oz.	6 fl. oz.	8 fl. oz.
Tinct. Opii Camph. . . . .	4 fl. oz.	8 fl. oz.	12 fl. oz.	16 fl. oz.
Tinct. Zingib. Mit. . . . .	1 fl. oz.	2 fl. oz.	3 fl. oz.	4 fl. oz.
Ung. Acid. Benz. Co. . . . .	4 oz.	8 oz.	12 oz.	1 lb.
Ung. Acid. Boric. . . . .	2 oz.	4 oz.	6 oz.	8 oz.
*Ung. Benzocain. Co. . . . .	2 oz.	4 oz.	6 oz.	8 oz.
Ung. Hydrarg. Ammon. . . . .	2 oz.	4 oz.	6 oz.	8 oz.
Ung. Methyl. Salicyl. . . . .	4 oz.	8 oz.	12 oz.	1 lb.
Ung. Zinc. Oxid. . . . .	4 oz.	8 oz.	12 oz.	1 lb.
Ung. Zinc. Undecen. . . . .	4 oz.	8 oz.	12 oz.	1 lb.

(e) Alternative drug or combination of drugs with similar therapeutic effects.  
 (a) Ships shall carry 25 tablets per member of the crew in addition to the quantities shown above.  
 (b) Alternative drug with similar therapeutic effects.

SCALE I.—MEDICINES—continued

Article <i>All drugs and materials must conform to the instructions preceding this scale</i>	Quantities for ships carrying passengers and crew not exceeding :—			
	250	500	750	1,000
*(c) Vaccin. Typho-paratyphos. in 10 c.c. vial.	1 vial	1 vial	1 vial	1 vial
(a) Vaccin. Vaccinia 4/5ths in 5 dose tubes 1/5th in 1 dose tubes.	An amount equivalent to one dose for every two persons on board			
*(b) Vitrell. Amyl. Nitris. 5 min.	6	6	6	6
Zinc. Oxid. . . . .	1 oz.	2 oz.	3 oz.	4 oz.
*Zinc. Sulph. . . . .	2 oz.	2 oz.	2 oz.	2 oz.

(a) To be kept in a cold chamber between 12° and 20°F ; if no cold chamber at that temperature is available it should be kept in a domestic refrigerator in or on the freezing compartment so that it is maintained constantly at a temperature of not more than 32°F. It must be replaced within 12 months of the date of issue on the label.

(b) To be labelled with an additional label as follows :  
 Ministry of Transport *Scale I and II Ships, VITRELL.*  
 AMYL. NITRIS. (Amyl. Nitrite). To be replaced within twelve months from (date of supply). This substance is subject to decomposition and it may be DANGEROUS to use it after that period.

SCALE I—MEDICAL STORES  
SUNDRIES

Article <i>All drugs and materials must conform to the instructions preceding this scale</i>	Special Information	Quantities for ships carrying passengers and crew not exceeding :—			
		250	500	750	1,000
Antiseptic . . . .	To conform to specification for Antiseptics given in Appendix A of this Schedule.	1 pint	2 pints	3 pints	4 pints
Anti-V.D. Outfit . .		For the first 50 members of the crew, one outfit per member and one outfit for every two members of the crew exceeding 50, maximum quantity 1 gross.			
*Basin . . . .	To be of good quality enamelled iron, anodised Aluminium, Stainless steel or plastic. Minimum size 8" diameter by 4" depth.	1	2	3	4
*Bedpan . . . .	To be of good quality enamelled iron or stainless steel. Perfection type, large size.	2	2	4	4

(c) To be kept constantly at a temperature not less than 34° F. or higher than 50° F. and to be renewed within 18 months of the date of issue on the label.  
 (d) Protect from light.

SCALE I.—MEDICAL STORES—SUNDRIES—continued

Article <i>All drugs and materials must conform to the instructions preceding this scale</i>	Special Information	Quantities for ships carrying passengers and crew not exceeding :—			
		250	500	750	1,000
*Books—					
The Ship Captain's Medical Guide, latest edition, with amendments.	.. .. .	1	1	1	1
Merchant Shipping Medical Scales, latest edition with amendments.	.. .. .	1	1	1	1
British Pharmaceutical Codex, latest edition	.. .. .	1	1	1	1
Bottles—					
2 oz. .. ..	Graduated teaspoons ..	1½ doz.	-	-	-
6 oz. .. ..	Graduated tablespoons ..	3 doz.	3 doz.	4½ doz.	6 doz.
2 oz. .. ..	Fluted poison ..	½ doz.	6 doz.	9 doz.	12 doz.
6 oz. .. ..	Fluted poison ..	1 doz.	1 doz.	1½ doz.	2 doz.
Boxes—					
Ointment .. ..	Nested.. ..	1 doz.	2 doz.	3 doz.	4 doz.
Pill .. ..	Nested.. ..	1 doz. nests	2 doz. nests	3 doz. nests	4 doz. nests
Corks .. ..	To fit 2 oz. bottles ..	1 doz. nests	2 doz. nests	3 doz. nests	4 doz. nests
*Cups .. ..	To fit 6 oz. bottles ..	3 doz. nests	6 doz. nests	9 doz. nests	12 doz. nests
*Disinfectant .. ..	Porcelain, for invalid feeding	6 doz. 3	12 doz. 3	18 doz. 3	24 doz. 3
	To conform to the specification for Disinfectants given in Appendix A of this Schedule	1½ galls.	3 galls.	4½ galls.	6 galls.
*Douche Reservoir	To be of rustless and stainless metal or of glass in metal frame, 2 pints, with 6 ft. of best rubber tubing and stopcock	2	2	2	2
*Eye Baths .. ..	To be of glass, porcelain or plastic which is unaffected by immersion in boiling water for at least 5 minutes	3	3	3	3
*Eye Droppers .. ..	.. .. .	3	3	3	3
*Eye Shades .. ..	To be of cardboard ..	3	3	3	3
*Finger Cots, Rubber	Assorted sizes.. ..	3	6	9	12
		6	12	18	24

## SCALE I.—MEDICAL STORES—SUNDRIES—continued

Article <i>All drugs and materials must conform to the instructions preceding this scale</i>	Special Information	Quantities for ships carrying passengers and crew not exceeding :—			
		250	500	750	1,000
*First Aid Satchel ..	The following to be supplied complete in a strong canvas bag with a strap for carrying :— 8 triangular band-ages 4 standard dressings No. 13 2 standard dressings No. 14 1 standard dressing No. 15 $\frac{1}{2}$ lb. roll of cotton wool 6 brass, plated safety pins, 2" on a card	1	1	1	1
*Funnels .. ..	Enamel, glass or plastic (2" and 5")	2	2	2	2
*Gloves, Rubber— Post-mortem .. ..	Size $7\frac{1}{2}$ .. ..	1 pair	1 pair	1 pair	1 pair
Surgical .. ..	Size $8\frac{1}{2}$ .. ..	2 pairs	2 pairs	2 pairs	2 pairs
*Hot Water Bottles	8" x 12" approximately, rubber, with covers	2	4	6	8
*Ice Bag .. ..	.. ..	1	1	1	1
*India rubber sheeting	1 yd. wide, to be rolled on a wooden core, surface to be smooth and non-adhesive.	2 yds.	4 yds.	6 yds.	8 yds.
Infants' prepared milk food	In 1 lb. tins .. ..	1 lb.	2 lb.	3 lb.	4 lb.
Insecticide— *(a) Liquid	To conform to the specifications given in Appendix C of this Schedule.	An amount equal to			24
		6 galls.	12 galls.	18 galls.	galls.
* (a) Hand Sprayer Powder ..		2	2	2	2
Invalid prepared milk food	In 1 lb. tins .. ..	4 oz.	8 oz.	12 oz.	1 lb.
Labels—		1 lb.	2 lb.	3 lb.	4 lb.
Plain .. ..	In packets of 100 .. ..		1	2	3
*Poison .. ..	In packets of 50 .. ..		1	1	1

(a) Pre-packed press-button pressure canisters may replace wholly or in part liquid insecticide. The volume of the contents of the canisters shall not be less than one quarter of the volume of the diluted liquid insecticide which they replace.

No hand sprayer need be carried if all the liquid insecticide solution is replaced by pressure canisters.

Article <i>All drugs and materials must conform to the instructions preceding this scale</i>	Special Information	Quantities for ships carrying passengers and crew not exceeding :—			
		250	500	750	1,000
*Measures—					
2 dr. . . . .	Glass, graduated, Government stamped	2	2	2	2
1 oz. . . . .	Glass, graduated, Government stamped	2	2	2	2
4 oz. . . . .	Glass, graduated, Government stamped	1	1	1	1
20 oz. . . . .	Glass graduated	1	1	1	1
*Methylated spirit (mineralised)	.. . . .	1 pint	2 pints	3 pints	4 pints
*Mortar and pestle	(Wedgwood) (No. 2 size)	1	1	1	1

Mosquito Repellent

Dimethyl Phthalate in 2 oz. bottles. Bottle to bear a label with the following Caution :—

One bottle per member of the crew plus a minimum reserve of 10 per cent.

Dimethyl Phthalate is a solvent for lacquer, paint and plastic articles. It should not be brought into contact with spectacle frames, watch glasses, fountain pens, etc.

For issue to each member of the crew as a protective measure against mosquitoes, when the vessel is in a malarious area. It is estimated that a 2 oz. bottle should last about two weeks. When it is known that the vessel is going to remain in a malarious area for a considerable period the reserve carried should be increased accordingly.

Article <i>All drugs and materials must conform to the instruc- tions preceeding this scale</i>	Special Information	Quantities for ships carrying passengers and crew not exceeding :—			
		250	500	750	1,000
*Oxygen .. .. .	.. .. .				
*Oxygen Therapy Outfit	To conform to the spe- cification given in Appendix D of this Schedule.	44 cu. ft. 1 outfit	44 cu. ft. 1 outfit	88 cu. ft. 1 outfit	132 cu. ft. 1 outfit
*Palette Knife— 4" blade .. .. . 9" blade .. .. .	The blade to be of rust- less and stain less steel, with wooden handle.	1 1	1 1	1 1	1 1
Paper— * Dispensary .. .. . * Filter .. .. . * Paraformaldehyde	White demy In sizes to fit funnels .. In tablets or powder for fumigation, with two suitable lamps.	1 qr. 25 1 lb.	1 qr. 50 1 lb.	1 qr. 75 1 lb.	1 qr. 100 1 lb.
*Safety pins .. .. . Salt in Urine Test Paper	Brass, plated, 2" .. .. . In books of 20 .. .. .	5 doz. 3	5 doz. 3	5 doz. 3	5 doz. 3
*Scale .. .. .	Standard pillar dispens- ing and weights	1	1	1	1
*Sputum mug .. .. .	To be of metal or ena- melled iron with hinged lid.	3	3	3	3
(a) Stabilised Chlor- ide of Lime	For sterilisation of drinking water (in $\frac{1}{2}$ lb. sealed tins). To conform to specifica- tion given in Appen- dix E of this Schedule.	(a)	(a)	(a)	(a)
*Stretcher— Neil Robertson .. .. . Canvas folding	Military type or equiva- lent	1 1	1 1	1 1	1 1
*Temperature Charts	Morning and Evening and four-hourly com- bined Charts for pulse, respirations and temperature.	2 doz. of each	2 doz. of each	2 doz. of each	2 doz. of each

(a) The number of tins to be carried shall be calculated on the amount of stabilised chloride of lime required to produce a concentration of one part of chlorine per million parts of water in the largest fresh water tank in the ship (a quarter pound tin will be required for approximately 28 tons of water). Stabilised chloride of lime need not be carried if vessel equipped with an efficient chlorinating plant.

## SCALE I.—MEDICAL STORES—SUNDRIES—continued

Article <i>All drugs and materials must conform to the instructions preceding this scale</i>	Special Information	Quantities for ships carrying passengers and crew not exceeding :—				
		250	500	750	1,000	
*Urinary testing apparatus	Rack for 6 test-tubes, urinometer, spirit lamp, litmus paper, 2 pipettes, 12 test tubes; one 2 oz. bottle containing nitric acid and one 2 oz. bottle containing acetic acid; one 4 oz. bottle containing Benedict's Solution (Qualitative).	1 set	1 set	1 set	1 set	
*Urine bottle	Enamelled iron, plastic, polythene or equivalent with handle, for male use.		1	2	3	4
*Vaccine expellers	.. .. .		3	3	3	3

SCALE I.—MEDICAL STORES  
INSTRUMENTS AND APPLIANCES

Irrespective of number of persons carried and length of voyage except where indicated

Article	Quantity
Main instrument case, metal lined, with trays, or white enamelled, with glass shelves containing the following:	1
Catheters, prostatic, silver plated, sizes 6, 8 and 12, one of each .. .. .	3
(a) Director, hernia .. .. .	1
Elevator, skull .. .. .	1
(a) Forceps—	
Artery, Spencer Wells, 7" .. .. .	12 pairs
Aural, Cumberbatch's .. .. .	1 pair
Bone, angled on flat, 7" .. .. .	1 pair
Dissecting, 7" .. .. .	2 pairs
Laryngeal, Mackenzie's opening antero-posteriorly	1 pair
Tongue, Mayo's pattern, 7" .. .. .	1 pair
Gouge, Robert Jones's, Arthrodesis, $\frac{1}{4}$ " .. .. .	1
(a) Knives—	
Blades, No. 23, B.P. type .. .. .	2 doz.
Handles B.P. type, suitable for No. 23 blades .. .. .	2
Hernia .. .. .	1
Tenotomy, sharp-pointed, Guy's pattern .. .. .	1
Mallet with lead core .. .. .	1
(a) Mouth gag, Mason's .. .. .	1
Needle, aneurism .. .. .	1
(a) Needle holder, 8" .. .. .	1
Retractor, wound, double-ended, Navy patterns, $1\frac{1}{4}$ " wide .. .. .	2

SCALE I.—MEDICAL STORES  
INSTRUMENTS AND APPLIANCES—continued  
Irrespective of number of persons carried and length of voyage except where  
indicated

Article		Quantity
	Saws—	
	Amputation, 8" blade .. .. .	1
(a)	Fergusson's, small .. .. .	1
(a)	Scissors—	
	Blunt-pointed, 7" .. .. .	1 pair
	One blade sharp-pointed, and the other blunt- pointed, 7" .. .. .	1 pair
	Trephine, carbon steel, $\frac{3}{4}$ .. .. .	1 pair
(a)	Trocars and cannulae, sizes 8, 16, and 21 French catheter gauge .. .. .	3
	Minor instrument case of washable canvas containing the following :—	1
(a)	Director, probe pointed, 6" .. .. .	1
(a)	Eye spud (with covered point) .. .. .	1
(a)	Forceps—	
	Artery, Spencer Wells' 6" .. .. .	2 pairs
	Dissecting, 6" .. .. .	1 pair
	Dressing, 6" .. .. .	1 pair
	Sinus, 6" .. .. .	1 pair
	Splinter, 4" .. .. .	1 pair
	Probe, with eye (silver) .. .. .	1
(a)	Scalpel, 6" .. .. .	1
(a)	Scissors—	
	Blunt pointed, 6" .. .. .	1 pair
	One blade sharp-pointed, and the other blunt- pointed, 6" .. .. .	1 pair
(a)	Midwifery instrument case of washable canvas containing the follow- ing :—	1
	Curette .. .. .	1
	Curette, flushing .. .. .	1
	Dilators (Hegar) .. .. .	1 set
	Forceps—	
	Obstetric (axis traction) .. .. .	1 pair
	Uterine (Herman's No. 10) .. .. .	1 pair
	Speculum, double duck-bill (Sim's) .. .. .	1
	Uterine Sound (Sim's) .. .. .	1
	Volsellum .. .. .	1
	Dental instrument case of washable canvas containing the following :—	1
(a)	Dental syringe, all metal, together with six needles .. .. .	1
(a)	Elevator, hospital pattern, in metal handle—	
	Left, stamped "Left elevator" .. .. .	1
	Right stamped "Right elevator" .. .. .	1
(a)	Forceps—	
	Dental packing .. .. .	1 pair
	Incisor—	
	Lower, stamped "Lower incisor" .. .. .	1 pair
	Upper, stamped "Upper incisor" .. .. .	1 pair
	Molar—	
	Lower, stamped "Lower molar" .. .. .	1 pair
	Upper left, stamped "Upper left molar" .. .. .	1 pair
	Upper right, stamped "Upper right molar" .. .. .	1 pair

(a) To be of rustless and stainless steel.

SCALE I.—MEDICAL STORES  
INSTRUMENTS AND APPLIANCES—*continued*

Article	Quantity
Stump—	
Lower, stamped "Lower stump" .. .. .	1 pair
Upper, stamped "Upper stump" .. .. .	1 pair
(a) Probe, Moon's single ended .. .. .	1
Airway and mouth, Hewitts or Equivalent, set of three .. .. .	1 set
Applicators, wooden .. .. .	100
Bougies, gum elastic, sizes 2, 4, 6 and 8 .. .. .	1 container
English gauge in glass or metal container with a sprinkling of French chalk.	
Catgut—	
Straight intestinal needles, sizes 4 and 8, threaded with 00 catgut (28") in sealed glass tubes, 2 of each .. .. .	4
20-day, in sealed glass tubes (28"), Nos. 0, 1 and 3, 6 of each .. .. .	18
Catheters—	
With olivary ends, gum elastic and stilettes—1 full set together with 3 Bi-Coudes gum elastic, sizes 6, 8 and 10 English gauge in glass or plastic cylinder or metal box with hinged lid with a sprinkling of French chalk .. .. .	1 container
Jacques rubber, sizes 4, 6, 8, 10 and 12 in glass or plastic cylinder or metal box with hinged lid with a sprinkling of French chalk .. .. .	1 container
Diagnostic set containing May ophthalmoscope, auriscope with three interchangeable specula, Duplay nasal speculum, bent arm throat lamp, one laryngeal mirror one post-nasal mirror, holder for wooden tongue spatula, large battery handle and spare lamp.	1 set
Drainage—	
Tubing, rubber, in 1 ft. lengths of each Nos. 5, 10 and 20 gauge .. .. .	3 lengths
Corrugated rubber sheeting, 12" × 6" .. .. .	1 sheet
Drop bottle, chloroform, 2 oz. graduated .. .. .	1
Dropper, ether, Bellamy Gardner's .. .. .	1
(a) Eye spud with covered point .. .. .	1
Inhaler, Schimmelbusch. . . . .	1
Microscope slides .. .. .	6
Needles—	
Anti-toxin, assorted sizes Record Mount .. .. .	6
(b) Hypodermic No. 15, diameter 0.6 mm., length 23 mm. Record Mount .. .. .	1 doz.
(b) Hypodermic No. 0, diameter 0.9 mm., length 41 mm. Record Mount .. .. .	1 doz.
(b) Drawing up (piercing end), diameter 1.83 mm., length 64 mm. Record Mount .. .. .	3
Lumbar puncture, 3½", Howard Jones, 20 B.W.G. . . . .	2
Probang, oesophageal, bristle, gum elastic, with sponge end .. .. .	1
Ryle's duodenal tube .. .. .	1
Shears, plaster, Swedish pattern, modified Lorenz's .. .. .	1
Silk, 4 sizes on metal reel. . . . .	1 reel
Silkworm gut (assorted sizes), box containing 50 .. .. .	1 box
Sphygmomanometer, portable unspillable mercury-type .. .. .	1

(a) To be of rustless and stainless steel.

SCALE I.—MEDICAL STORES  
INSTRUMENTS AND APPLIANCES—*continued*

Article	Quantity
Splints—	1 set
Assorted, thigh, leg and arm sizes .. .. .	1 yd.
Gooch splinting (36" wide) .. .. .	3
Thomas's small, medium and large .. .. .	1
Steriliser, steam or electrically heated with automatic cut-out (large enough to contain midwifery forceps)	1
Stethoscope, binaural, complete .. .. .	1
Stomach tube 42" (gauge 18-20) in red rubber with unbreakable funnel to fit, and wooden gag .. .. .	2
Suspensory bandages with under straps—	2
Small .. .. .	2
Medium .. .. .	2
Large .. .. .	3 doz.
Suture needles, round bodies, cutting-edge, straight, half-curved and curved, assorted sizes .. .. .	1
Syringe, ear, metal or rubber, 4 oz. .. .. .	1
Syringe, glycerin injection, with vulcanite nozzle, $\frac{1}{2}$ oz. .. .. .	2
Syringe, Higginson's with enema nozzle and one No. 8 Jacques rubber catheter .. .. .	3
Syringe, hypodermic 2 ml. } Glass or nylon barrel, fitted with metal nozzle (for Record Mount) in metal case. The syringe must pass the Thermal Shock Test and Corrosion Tests laid down in British Standard 1263 of 1946	1
Syringe, anti-toxin 10 ml. }	
Table, operation, metal with lighthotomy crutches. Table legs to be provided with suitable fitting for attachment to deck	3
Thermometer, clinical, in metal or plastic protective case, lens fronted, $\frac{1}{2}$ min. and stamped N.P.L.	100
Tongue, depressors, wooden .. .. .	1
Tourniquet, Esmasch's or Samway's .. .. .	1 set
Tracheotomy Set consisting of:—	
Tracheotomy double tubes, assorted (including infants' size) .. .. .	3
Trachea dilator .. .. .	1
Sharp hook .. .. .	1
Tray, enamelled iron or other suitable material—	
10" x 7" .. .. .	1
12" x 9" .. .. .	2
Kidney shaped, 10" .. .. .	
Truss, elastic band type—	
Single 42" with rat-tailed pad right .. .. .	2
Single 42" with rat-tailed pad left .. .. .	2
Double 42" with rat-tail pads .. .. .	2

(a) To be of rustless and stainless steel.

(b) Quantities to be doubled if more than 1,000 persons carried.

SCALE I.—MEDICAL STORES—DRESSINGS

Article. <i>All drugs and materials must conform to the instructions preceding this scale</i>	Details regarding Packaging and Labelling	Quantities for ships carrying passengers and crew not exceeding :—			
		250	500	750	1,000
Bandages—					
*Elastic Adhesive 2½" × 3 yds. (unstretched).	To be supplied in metal containers.	2 containers	4 containers	6 containers	8 container
*Plaster of Paris 3" × 3 yds. ..	In sealed containers prepared for use.	6 containers	12 containers	18 containers	24 containers
*Triangular—not less than 36" side, 51" base.	Each bandage to be individually wrapped and labelled; measurements to be stated on label.	6	6	6	6
Unbleached Calico 6" × 6 yds.	Ditto .. .. .	6	6	6	6
W.O.W.— 1" × 3 yds. ..	Ditto .. .. .	18	36	54	72
2" × 4 yds. ..	Ditto .. .. .	18	36	54	72
3" × 4 yds. ..	Ditto .. .. .	9	18	27	36
Cotton Wool— 2 oz. 8½" wide (or 8 oz. 12" wide)	To be supplied rolled. The packets to be labelled with the words "Cotton Wool"; measurements to be stated on the label. The cotton wool to be in one continuous length as follows :— 2 oz. size : approximately 30" 8 oz. size : approximately 60"	12 2 oz. pkts. or 8 2 oz. pkts. and 1 8 oz. pkts.	12 2 oz. pkts. or 12 2 oz. pkts. and 3 8 oz. pkts.	27 36 pkts. or 20 2 oz. pkts. and 4 8 oz. pkts.	36 48 pkts. or 24 2 oz. pkts. and 8 8 oz. pkts.
Dressings—					
*Burn and Wound	Paraffin Gauze Dressing (B.P.C.). Packaging and labelling to conform to the specification given in Appendix F of the Schedule.	3 cartons	6 cartons	9 cartons	12 cartons
*(a) Standard No. 13	Each dressing to be individually wrapped and labelled as follows : No. 13 Small B.P.C. Plain Wound Dressing 4" × 3". Directions — Unwind short end of bandage. Hold short and rolled end of bandage to straighten out pad. Apply without touching sterilised pad or wound and bandage firmly.	6	6	6	6

(a) For replenishing First Aid Satchel.

SCALE I.—MEDICAL STORES—DRESSINGS—*continued*

Article. <i>All drugs and materials must conform to the instructions preceding this scale</i>	Details regarding Packaging and Labelling	Quantities for ships carrying passengers and crew not exceeding :—			
		250	500	750	1,000
Dressings— <i>contd.</i> *(a) Standard No. 14	Each dressing to be individually wrapped and labelled as follows :— No. 14 Medium B.P.C. Plain Wound Dressing 6" × 4". Directions — Unwind short end of bandage. Hold short and rolled end of bandage to straighten out pad. Apply without touching sterilised pad or wound and bandage firmly.	6	6	6	6
*(a) Standard No. 15	Each dressing to be individually wrapped and labelled as follows :— No. 15 Large B.P.C. Plain Wound Dressing 8" × 6". Directions — Unwind short end of bandage. Hold short and rolled end of bandage to straighten out pad. Apply without touching sterilised pad or wound and bandage firmly.	6	6	6	6
Gauze— Absorbent— 36" × 6" .. 36" × 12" .. 36" × 36" ..	To be supplied in packets labelled with the words "Gauze Absorbent Sterilized", measurements to be stated on label.	9 9 9	18 18 18	27 27 27	36 36 36
*Absorbent Ribbon 1" × 6 yds. ..	To be supplied in packets labelled with the words "Gauze Absorbent Ribbon Sterilized," measurements to be stated on label.	1 roll	2 rolls	3 rolls	4 rolls
Gauze and Cotton Tissue. *Jaconet 36" ..	.. .. . .. .. .	1 lb. 2 yds.	2 lb. 2 yds.	3 lb. 2 yds.	4 lb. 2 yds.

(a) For replenishing First Aid Satchel.

SCALE I.—MEDICAL STORES  
DRESSINGS—continued

Article <i>All drugs and materials must conform to the instructions preceding this scale</i>	Details regarding Packaging and Labelling	Quantities for ships carrying passengers and crew not exceeding:—			
		250	500	750	1,000
Lint—					
Absorbent—	To be supplied in packets labelled with the words "Lint Absorbent Sterilised" measurements to be stated on label.				
6" x 12" ..		18	24	36	48
12" x 12" ..		9	18	27	36
Boric—	To be supplied in packets labelled with the words "Lint Boric", measurements to be stated on label.				
2" x 6" ..		9	18	27	36
6" x 12" ..		12	24	36	48
Plaster—Zinc Oxide					
* $\frac{1}{2}$ " x 5 yds. ..	To be supplied on a spool	1 spool	2 spools	3 spools	4 spools
*1" x 5 yds. ..	To be supplied on a spool	1 spool	2 spools	3 spools	4 spools
*3" x 5 yds. ..	To be supplied on a spool	1 spool	2 spools	3 spools	4 spools
*Sterilised Dressings, etc., for major operation.		1 set	1 set	1 set	1 set
2 rolls white absorbent gauze, each 6 yds., 36" in width to be folded 9" wide before rolling.					
6 absorbent gauze pads (twelve thicknesses of gauze)					
10" x 20"					
5 dozen gauze swabs 6" x 6" (12 thicknesses of gauze stitched at edges) packed in dozens.					
1 manytail calico bandage (War Office pattern).	The whole of the dressings to be wrapped in greaseproof paper, sterilised, and encased in one or two hermetically sealed metal containers and labelled "Sterilised dressings for major operation." .. ..				
2 5" bandages,					
6 yds. white open weave.					
1 packet safety pins;					

SCALE I.—MEDICAL STORES  
DRESSINGS—*continued*

Article <i>All drugs and materials must conform to the instructions preceding this scale</i>	Details regarding Packaging and Labelling	Quantities for ships carrying passengers and crew not exceeding :—			
		250	500	750	1,000
1 doz. size 3. doz. size 4. 8 surgical towels 18" x 32" weight not less than 24 oz. per doz. 2 surgeon's caps, 2 gowns and 2 surgical masks. *Unbleached Cali- co 38" wide.	.. .. .	3 yds.	3 yds.	3 yds.	3 yds.

SCALE II

1. QUANTITIES

(1) The quantities of medicines set out in this Scale are the requirements for a voyage of twelve months duration and shall be carried on all voyages of over six months' duration. On voyages of six months duration or less, not less than half the said quantities shall be carried, except where otherwise indicated in this Scale.

(2) The quantities of medical stores set out in this Scale shall be carried on all voyages.

2. GENERAL REQUIREMENTS

The medicines and medical stores comprised in this Scale shall comply with the following requirements :

(1) They shall conform to the standards and requirements of the current issue of the British Pharmacopoeia, the British Pharmaceutical Codex or the National Formulary, where those standards and requirements are applicable, and shall also comply with any special requirements indicated in this Scale.

(2) Containers or wrappings of medicines shall be plainly and durably labelled to show :

(a) the English name of the contents as set out in the first column of this Scale ;

(b) the particulars of the medicines given in the second column of this Scale printed in less prominent type than the information under (a). Where the word "POISON" is to be included with other particulars on the label it shall be printed in capital letters and either in red lettering or on a red background ;

(c) the minimum and maximum dose of the contents for an adult, as set out in the British Pharmacopoeia, the British Pharmaceutical Codex or the National Formulary ;

(d) the name and address of the supplier, which may be indicated on a separate label shall occupy not more than 25 per cent of the total label space.

(3) Labels shall be rendered resistant to moisture either by the use of an efficient label varnish which must cover the label and overlap the edges, or by the use of some alternative method the effect of which is not inferior to varnishing.

## SCALE II.—MEDICINES

Names of Medicines in English	Other particulars to be included on the label	Special information about composition, packaging, etc.	Quantities for ships carrying the undermentioned number of persons	
			Up to 40 persons	Over 40 persons
Amyl. Nitrite capsules	Vitrell. Amyl. Nitris 5 min.	No reduction in quantities for voyages of 6 months' duration and under. To be labelled with an additional label as follows : "MINISTRY OF TRANSPORT <i>Scale I and II Ships</i> , VITRELL. AMYL. NITRIS. (Amyl. Nitrite). Not to be used after twelve months from . . . (date of supply). This substance is subject to decomposition and it may be DANGEROUS to use it after that period."	6	6
Arachis Oil . . . Aromatic Spirit of Ammonia. Aspirin Tablets	Ol. Arach. . . . . Sp. Ammon. Aromat. Tab. Acid. Acetylsalicyl. 5 gr.	— — —	— — 250	1 pint 8 fl. oz. 500
Benzyl Benzoate Application.	Applicat. Benzyl Benz. For external use only.	To be supplied in green or amber fluted bottles	2 pints	4 pints
Black Draught Boric Acid . . . Calamine Lotion	Mist. Senn. Co. . . Acid. Boric. Cryst. Lot. Calamin. . . For external use only. Shake the bottle.	— — To be supplied in green or amber fluted bottles.	— — 4 pints	1 gal. 8 oz. 8 pints
Calomel Tablets	Tab. Hydrarg. Subchlor. 1 gr.	—	—	100 200
Carbolised Resin.	Res. Carbol. . .	To be supplied in a wide-mouthed bottle so that dental tweezers can be inserted.	1 fl. oz.	1 fl. oz.

SCALE II.—MEDICINES—*continued*

Names of Medicines in English	Other particulars to be included on the label	Special information about composition, packaging, etc.	Quantities for ships carrying the undermentioned number of persons	
			Up to 40 persons	Over 40 persons
Castor Oil Chloramphenicol.	Ol. Ricin. . . . . Caps. Chloramphen. 0.25 gramme.	— To be labelled with an additional label as follows : "MINISTRY OF TRANSPORT" <i>Scale II Ships.</i> CHLORAMPHENICOL. To be used only for the treatment of enteric (typhoid) feveras directed in the Ship Captain's Medical Guide.	2 pints 120 capsules	4 pints 120 capsules
Chloroquine Tablets.	Tab. Chloroquin. Phosphat. 0.25 gramme or Tab. Chloroquin. Sulphat. 0.20 gramme.	—	250	500
Cocaine Eye-drops.	Gutt. Cocain. et Hydrarg. Perchlor. Oleos. B.P.C. POISON.—For external use only. <i>Directions for use :</i> With the aid of the dropper put two drops into the eye every five minutes until the eye is insensitive. Usually three or four doses suffice. The eye should then be ready, and the foreign body can be removed with a previously sterilised eye spud. Afterwards an eye shade should be used for 24 hours.	To be supplied in green or amber fluted bottles with dropper attached. No reduction in quantities for voyages of 6 months' duration and under.	1 fl. oz.	1 fl. oz.
Compound Codeine Tablets.	Tab. Codein. Co. CAUTION.— It is dangerous to exceed the stated dose.	—	150	300

## SCALE II.—MEDICINES—continued

Names of Medicines in English	Other particulars to be included on the label	Special information about composition, packaging, etc.	Quantities for ships carrying the undermentioned number of persons	
			Up to 40 persons	Over 40 persons
Coramine Injection.	Inj. Nikethamide.	To be supplied in 2ml. ampoules	6 Ampoules	6 Ampoules
Cough Linctus	Linct. Scill. Opiat. CAUTION.—It is dangerous to exceed the stated dose.	—	2 pints	4 pints
Cream of Tartar Dover's Powder Tablets.	Pot. Tart. Acid. Tab. Ipecac. et Opii 5 gr. POISON.	—	$\frac{1}{2}$ lb. 100	$\frac{1}{2}$ lb. 200
Dusting Powder	Consper. Zinc. Oxid. et Amyli Co.	No reduction in quantities for voyages of 6 months' duration and under.	2 oz.	4 oz.
Ear Drops	Aurist. Phenol. These drops must not be diluted with water. POISON.	No reduction in quantities for voyages of 6 months' duration and under.	1 fl. oz.	1 fl. oz.
Ephedrine Tablets	Tab. Ephed. Hdyrochlor. $\frac{1}{2}$ gr. CAUTION.—It is dangerous to exceed the stated dose.	No reduction in quantities for voyages of 6 months' duration and under.	100	100
Epsom Salts	Mag. Sulp.	To be supplied in 1 oz. packets.	4 lb.	8 lb.
Eye drops Antiseptic	Gutt. Sulphacetamid Mit. (protect from light).	To be supplied in green or amber fluted bottles with dropper attached.	1 fl. oz.	fl. oz.
Friars' Balsam	Tinct. Benzoin. Co.	—	4 fl. oz.	8 fl. oz.
Fungicide Ringworm powder.	Consper. Zinc. Undecen.	—	4 oz.	4 oz.
Goulard's Extract	Liq. Plumb. Subacet. Fort. POISON.—For external use only. For use prepare Goulard's Lotion by diluting two teaspoonfuls to a pint of water.	To be supplied in green or amber fluted bottles.	2 fl. oz.	4 fl. oz.

SCALE II.—MEDICINES—*continued*

Names of Medicines in English	Other particulars to be included on the label	Special information about composition, packaging, etc.	Quantities for ships carrying the undermentioned number of persons	
			Up to 40 persons	Over 40 persons
Heart Tablets ..	Tab. Glyceryl Trinitrini. 1/130 grain. The tablet should be chewed before swallowing. Keep in a cool place, protect from light.	—	24	24
Kaolin Poultice .. Kaolin Stomach Mixture (Kaolin Sedative Mixture)	Cataplasm. Kaolin. Mist. Kaolin. et Morph. CAUTION. —It is dangerous to exceed the stated dose. Shake the bottle.	In ½ lb. sealed tins —	4 tins 1 pint	8 tins 2 pints
Laudanum ..	Tinct. Opii. .. POISON.	—	4 fl. oz.	6 fl. oz.
Methyl Salicylate Liniment	Lin. Methyl. Salicyl. For external use only.	To be supplied in green or amber fluted bottles.	½ pint	1 pint
Morphine Ampoules ¼ gr.	POISON .. ..	Ampoule Syringes containing a solution of either a morphine salt equivalent to Anhydrous Morphine ¼ gr. in 1 c.c. or Papaveretum B.P. C. ½ gr. in 1 c.c. (in screw-capped metal drums of six). No reduction in quantities to be carried for voyages of 6 months' duration and under.	1 drum	2 drums
Morphine Tablets	Tab. Morph. Hydrochlor. ¼ gr. or Tab. Morph. Sulph. ¼ gr. POISON.	These tablets are for oral use and hypodermic tablets must not be supplied. No reduction in quantities to be carried for voyages of 6 months' duration and under.	25	25
Oil of Turpentine	Ol. Terebinth. ..	—	4 fl. oz.	8 fl. oz.

## SCALE II.—MEDICINES—continued

Names of medicines in English	Other particulars to be included on the label	Special information about composition, packaging, etc.	Quantities for ships carrying the undermentioned number of persons	
			Up to 40 persons	Over 40 persons
Proguanil "Paludrine" Tablets	Tab. Proguanil Hydrochlor. 0.1 gramme		50 per person	50 per person
Penicillin	Procaine Penicillin G. Fortified in rubber-capped vials and containing 300,000 international units of sterile procaine penicillin G. and 100,000 international units of crystalline penicillin salt with suitable suspending and buffering agents	In rubber-capped vials. Label to state the volume of sterile solvent to be added to the vial for the preparation of a suspension for intramuscular injection. To be kept in a cool dry place and renewed two years from the date of manufacture.	12 vials	24 vials
Penicilin V. Tablets or Capsules	Tab. or Caps. Phenoxymethyl penicil. 250 mg.	Keep in containers which prevent access of moisture and in a cool place.	—	100
Pile Ointment	Ung. Benzocain Co. Solv. Pot. Permang. 8½ gr.	—	—	4 oz. 50
Potassium Permanganate Solution	—	—	—	4 oz. 100
Tablets (a) Salt Tablets	Solv. Sod. Chlorid. 7 gr. with Dextros. 3 gr.	No reduction in quantities for voyages of 6 months' duration and under.	—	2,000
Seasickness Tablets	Tab. Hyoscin. Hydrobrom. 1/200 gr. POISON	—	—	50
Sedative Tablets	Tab. Butobarbiton. 1½ gr. POISON	—	—	50
Soda Mint Tablets	Tab. Sod. Bicarb. Co. Sod. Bicarb.	—	—	50
Sodium Bicarbonate	Paraff. Moll. Flav.	—	—	4 oz. 8 oz.
Soft Paraffin	Pulv. Mag. Trisil. Co.	—	—	8 oz. 8 oz.
Stomach Powder	Tab. Sulphadimid. 0.5 gramme. POISON	—	—	8 oz. 1 lb.
Sulphadimidine Tablets.	—	—	—	1 bot. 2 bots.
		To be supplied in bottles containing 500 tablets		

SCALE II.—MEDICINES—*continued*

Names of medicines in English	Other particulars to be included on the label	Special information about composition, packaging, etc.	Quantities for ships carrying the undermentioned number of persons	
			Up to 40 persons	Over 40 persons
Sulphaguanidine Tablets.	Tab. Sulphaguanidin. 0.5 grammes. POISON	—	200	400
Surgical Spirit	Sp. Chir. (B.P.C. No. 1)	—	$\frac{1}{2}$ pint	1 pint
Tincture of Iodine	Liq. Iod. Mit. For external use only	To be supplied in green or amber fluted bottles	$\frac{1}{2}$ pint	1 pint
Tonic Tablets	Tab. Ferr. Phosph. c. Quinin. et Strych. 30 min. CAUTION — It is dangerous to exceed the stated dose	—	150	300
Vegetable Laxative Tablets	Tab. Colocynth. et Jalap. Co. CAUTION.—It is dangerous to exceed the stated dose	—	200	400
Water for Injection	Aq. pro Inj. in 2 ml. ampoules	—	24 ampoules	48 ampoules
White precipitate Ointment	Ung. Hydrarg. Ammon. POISON	—	4 oz.	8 oz.
Whitfield's Ointment	Ung. Acid. Benz. Co.	—	4 oz.	8 oz.
Zinc Ointment	Ung. Zinc. Oxid.	—	4 oz.	8 oz.

SCALE II.—MEDICAL STORES—SUNDRIES

B 339

Article	Special information	Quantities for ships carrying the undermentioned number of persons	
		Up to 40 persons	Over 40 persons
Antiseptic .. .. .	To conform to the specification for Antiseptics given in Appendix A of this Schedule.		
Anti-V.D. Outfit .. .. .		1 pint	2 pints
	To conform to the specification given in Appendix B of this Schedule.		
Basin .. .. .	To be of good quality enamelled iron anodised aluminium, stainless steel or plastic minimum size 8" diameter by 4" depth, lettered "Medical".	For the first 50 members of the crew one outfit per member and one outfit for every two members of the crew exceeding 50	
Bedpan .. .. .		1	1
Books—	To be of good quality enamelled iron or stainless steel. Perfection type, large size.	1	1
Ship Captain's Medical Guide, latest edition with amendments.	.. .. .	1	1
Merchant Shipping Medical Scales, latest edition with amendments	.. .. .	1	1
Bottles—	Graduated teaspoons		
2 ozs. .. .. .	Graduated tablespoons .. .. .	6	12
6 ozs. .. .. .	Fluted poison .. .. .	6	12
2 ozs. .. .. .	Nested .. .. .	3	6
Boxes, ointment .. .. .	To fit 2 oz. bottles .. .. .	6 nests	12 nests
Corks .. .. .	To fit 6 oz. bottles .. .. .	18	36
	To conform to the specification for Disinfectants given in Appendix A of this Schedule.	12	24
Disinfectant .. .. .		1 gall.	2 gall.
Eye Baths .. .. .	To be of glass, porcelain or a plastic which is unaffected by immersion in boiling water for at least 5 minutes.	2	2
Eye Shades .. .. .	To be of cardboard .. .. .	3	6
Finger Stalls, Leather .. .. .	Assorted sizes .. .. .	6	12

SCALE II.—MEDICAL STORES—SUNDRIES—*continued*

Article	Special information	Quantities for ships carrying the undermentioned number of persons	
		Up to 40 persons	Over 40 persons
First Aid Satchel ..	The following to be supplied complete in a strong canvas bag with a strap for carrying: 8 triangular bandages, 4 standard dressings No. 13, 2 standard dressings No. 14, 1 standard dressing No. 15, $\frac{1}{2}$ lb. roll of cotton wool, 6 brass, plated safety pins, 2", on a card.	1	1
Gloves—Rubber Surgical—Rough	Size 8 .. .. .	2 pairs	2 pairs
Hot Water Bottles ..	8" x 12" (approximately) rubber, with covers	2	2
Indiarubber Sheeting ..	1 yd. x 2 yds. to be rolled on a wooden core, surface to be smooth and non-adhesive.	1	2
Insecticide— (a) Liquid .. ..	To conform to specification given in Appendix C of this Schedule	An amount equal to 3 gall. 6 gall. of the diluted product.	
(a) Hand Sprayer ..	To conform to specification given in Appendix C of this Schedule.	1	1
Powder .. .. .	To conform to specification given in Appendix C of this Schedule.	4 oz.	8 oz.
Labels— Plain .. .. .	In packets of 100 .. .. .	1 pkt.	1 pkt.
Poison .. .. .	In packets of 50 .. .. .	1 pkt.	1 pkt.
Measures 2 ozs. .. .. .	Graduated ozs., drs., tablespoons and teaspoons (Mason's wine) unstamped. The words ounces and drachms to be marked in full or abbreviated and not to be replaced by symbols.	2	2
2 drachms .. ..	Government stamped, conical, glass graduated drachms and minims. The words drachms and minims to be marked in full or abbreviated and not to be replaced by symbols.	2	2
Methylated Spirit (Mineralised).	.. .. .	1 pint	2 pints

(a) Pre-packed press-button pressure canisters may replace wholly or in part diluted liquid insecticide. The volume of the contents of the canisters shall not be less than one quarter of the volume of the diluted liquid insecticide which they replace.

No hand sprayer need be carried if all the liquid insecticide solution is replaced by pressure canisters.

## SCALE II.—MEDICAL STORES

## SUNDRIES—continued

Article	Special Information	Quantities for ships carrying the undermentioned number of persons	
		Up to 40 persons	Over 40 persons
Mosquito Repellent ..	Dimethyl Phthalate in 2 oz. bottles. Bottle to bear a label with the following caution: Dimethyl Phthalate is a solvent for lacquer, paint and plastic articles. It should not be brought into contact with spectacle frames, watch glasses, fountain pens, etc. For issue to each member of the crew as a protective measure against mosquitoes when the vessel is in a malarious area. It is estimated that a 2 oz. bottle should last about two weeks. When it is known that the vessel is going to remain in a malarious area for a considerable period the reserve carried should be increased accordingly	one bottle per member of the crew plus a minimum reserve of 10 per cent	
Neil Robertson Stretcher:			
Palette Knife, 4" blade ..	The blade to be of rustless and stainless steel, with wooden handle	1	1
Safety Pins ..	Brass, plated, 2" .. .. .	1 doz.	1 doz.
(a) Salt in Urine Test Papers	In books of 20. No reduction in quantities for voyages of 6 months' duration and under	2	2
Sputum Mug .. .. .	To be of metal or enamelled iron with hinged lid	1	1
(b) Stabilised Chloride of Lime	In $\frac{1}{2}$ lb. tins. To conform to specification given in Appendix E of this Schedule	(b)	(b)
Temperature Charts ..	Four-hourly combined Chart for pulse, respirations and temperature	3	3
Urine Bottle .. .. .	Enamelled iron, plastic, polythene or equivalent with handle for male use	1	1

(a) Ships proceeding to ports in the Persian Gulf, in the Red Sea or on the Arabian Coast shall carry in addition one book for every five members of the crew.

(b) The number of tins to be carried shall be calculated on the amount of Stabilised Chloride of Lime required to produce a concentration of one part of chlorine per million parts of water in the largest fresh water tank in the ship (a quarter pound tin will be required for approximately 28 tons of water.)

SCALE II.—MEDICAL STORES  
INSTRUMENTS AND APPLIANCES

Article	Special Information	Quantities for ships carrying the undermentioned number of persons	
		Up to 40 persons	Over 40 persons
Applicators—wooden, for throat	.. .. .	1 doz.	1 doz.
Canvas Roll for Instruments	For use as a container for Eye Spud, Forceps (Dental Packing, Dissecting, Epilation, Sinus, Spencer Wells), Scissors, Clinical Thermometers.	1	1
Catheters— Gum elastic, with olivary ends	Sizes 3, 5 and 7, one of each to be supplied with stilettes in a glass or plastic cylinder, or metal box with hinged lid with a sprinkling of French chalk.	1 container	1 container
Jacques Rubber . . . . .	Sizes 3, 5 and 7, one of each to be supplied in a glass or plastic cylinder or metal box with hinged lid with a sprinkling of French chalk	1 container	1 container
Eye Spud with covered point	To be of rustless and stainless steel	1	1
Forceps— Packing .. .. .	To be made of rustless and stainless steel throughout	1 pair	1 pair
Dissecting, 5" .. .. .	To be made of rustless and stainless steel throughout	1 pair	1 pair
Epilation with oblique ends for removal of splinters	To be made of rustless and stainless steel throughout	1 pair	1 pair
Sinus, 5" .. .. .	To be made of rustless and stainless steel throughout	1 pair	1 pair
Spencer Wells, 5" .. .. .	To be made of rustless and stainless steel throughout	2 pairs	2 pairs
Kidney Dish, 10" .. .. .	Enamelled iron .. .. .	1	1
Microscope Slides .. .. .	.. .. .	6	6
Needles, Hypodermic .. .. .	No. 0, diameter 0.9 mm., length 41 mm., Record Mount	6	6
Paget's Knife .. .. .	To be of rustless and stainless steel throughout and to be supplied in a metal or wooden box together with the scalpel	1	1

SCALE II.—MEDICAL STORES  
INSTRUMENTS AND APPLIANCES—continued

B 343

Article	Special Information	Quantities for ships carrying the undermentioned number of persons	
		Up to 40 persons	Over 40 persons
Scalpel .. .. .	1½" blade. To be of rustless and stainless steel throughout and to be supplied in a metal or wooden box together with the Paget's Knife	1	1
Scissors, 7" .. .. .	One blade sharp-pointed and the other blunt-pointed. To be of rustless and stainless steel	1 pair	1 pair
Sutures and Needles .. .. .	The sutures should be of nylon or silk, fitted to half curved eyeless needles with a cutting edge, size 10 or equivalent size. Each needle and suture to be sterile and closed in a sealed glass tube with a fracture scratch. Container label to give illustrated directions for breaking the tube	4	6
Splints— Common .. .. . Liston's Thigh .. .. .	Largest size .. .. . To measure not less than approx. 7" × 3" × 2"	1 set 1 1	1 set 1 1
Steriliser with spirit lamp (or steam or electrically heated type with auto- matic cutout)		1	1
Stomach Tube, 42" (gauge 18-20)	To be supplied in red rubber with unbreakable funnel to fit, and wooden gag	1	1
Suspensory bandages with under straps— Medium .. .. . Large .. .. .			
Syringe, Higginson's, with Enema Nozzle and Rubber Catheter.	The syringe with enema nozzle to be indelibly marked "For enema use only" and to be supplied in a box with one No. 8 Jacques Rubber Catheter.	2 2 1	4 4 1
Syringe, Higginson's with Ear Nozzle.	The syringe to be indelibly marked "For ear use only" and to be supplied in a box.	1	1
Syringe, Hypodermic. . .	2 ml. glass or nylon barrel fitted with a metal nozzle (for Record Mount), in metal case. The syringe must pass the Thermal Shock Test and Corrosion Tests laid down in British Standard 1263 of 1946	2	2

SCALE II.—MEDICAL STORES  
INSTRUMENTS AND APPLIANCES—*continued*

Article	Special Information	Quantities for ships carrying the undermentioned number of persons	
		Up to 40 persons	Over 40 persons
Thermometer, Clinical . .	To be supplied in metal or plastic protective case, lens fronted $\frac{1}{2}$ in. and stamped N.P.L.	2	3
Tongue Depressors . .	To be made of wood . . . .	1 doz.	2 doz.
Truss, elastic band type—			
Single 38" . .	With rat-tail pad, right . . . .	1	1
Single 38" . .	With rat-tail pad, left . . . .	1	1
Double, 38" . .	With rat-tail pads . . . .	1	1

SCALE II.—MEDICAL STORES  
DRESSINGS

Article <i>All materials must conform to the instructions at commencement of Scale II</i>	Details regarding packaging and labelling	Quantities for ships carrying the undermentioned number of persons	
		Up to 40 persons	Over 40 persons
Bandages— Crepe, 3" × 5 yds . .	Each bandage to be individually wrapped and labelled; measurements to be stated on label	3	3
Elastic Adhesive 2 $\frac{1}{2}$ " × 3 yds. (unstretched). Triangular, not less than 36" side, 51" base.	To be supplied in metal container	1 container 4	2 containers 8
W.O.W.— 1" × 3 yds. . . . .	Each bandage to be individually wrapped and labelled; measurements to be stated on label		
3" × 4 yds. . . . .	Ditto . . . . .	18	36
Cotton Wool— $\frac{1}{2}$ oz., 3" wide . . . . .	Ditto . . . . .	18	36
1 oz., 4 $\frac{1}{4}$ " wide . . . . .	To be supplied rolled. The packets to be labelled with the words "Cotton Wool"; measurements to be stated on the label. The cotton wool to be in one continuous length as follows:—	18 pkts. 18 pkts.	36 pkts. 36 pkts.
	$\frac{1}{2}$ oz. size . . . . .		
	1 oz. size . . . . .	21"-22" 28"-30"	

SCALE II.—MEDICAL STORES  
DRESSINGS—continued

B 345

Article. <i>All materials must conform to the instructions at commencement of Scale II</i>	Details regarding packaging and labelling	Quantities for ships carrying the undermentioned number of persons	
		Up to 40 persons	Over 40 persons
Dressings— Burn and Wound	Paraffin Gauze Dressing (B.P.C.). Packaging and labelling to conform to the specification given in Appendix F of this Schedule. Each dressing to be individually wrapped and labelled as follows :— No. 13 Small B.P.C. Plain Wound Dressing 4" × 3"	6 cartons	12 cartons
Standard No. 13	Directions.—Unwind short end of bandage. Hold short and rolled end of bandage to straighten out pad. Apply without touching sterilised pad or wound and bandage firmly.	12	24
Standard No. 14	Each dressing to be individually wrapped and labelled as follows :— No. 14 Medium B.P.C. Plain Wound Dressing 6" × 4"	6	12
Standard No. 15	Directions.—Unwind short end of bandage. Hold short and rolled end of bandage to straighten out pad. Apply without touching sterilised pad or wound and bandage firmly.	6	12
	Each dressing to be individually wrapped and labelled as follows :— No. 15 Large B.P.C. Plain Wound Dressing 8" × 6"		
	Directions.—Unwind short end of bandage. Hold short and rolled end of bandage to straighten out pad. Apply without touching sterilised pad or wound and bandage firmly.		

SCALE II.—MEDICAL STORES  
DRESSINGS—*continued*

Article. <i>All materials must conform to the instructions at commencement of Scale II</i>	Details regarding packaging and labelling	Quantities for ships carrying the undermentioned number of persons	
		Up to 40 persons	Over 40 persons
Gauze—			
Absorbent—			
36" × 12" ..	To be supplied in packets labelled with the words "Gauze Absorbent Sterilised"; measurements to be stated on label	12 pkts.	24 pkts.
36" × 36" ..		8 pkts.	16 pkts.
Absorbent Ribbon—			
1" × 6 yds.	To be supplied in packets labelled with the words "Gauze Absorbent Ribbon Sterilised"; measurements to be stated on label.	1 roll	1 roll
Jaconet .. .. .	.. .. .	1 sq. yd.	2 sq. yds
Lint—			
Absorbent—			
6" × 12" .. ..	To be supplied in packets labelled with the words "Lint Absorbent Sterilised"; measurements to be stated on label.	12 pkts.	18 pkts.
12" × 12" .. ..		12 pkts.	18 pkts.
Boric—			
2" × 6" .. ..	To be supplied in packets labelled "Lint Boric"; measurements to be stated on label	12 pkts.	24 pkts.
6" × 12" .. ..		12 pkts.	24 pkts.
Plaster—			
Elastic Adhesive, 1" × 3 yds. (unstretched).	To be supplied on a spool ..	1 spool	2 spools
Zinc Oxide 1" × 5 yds.	To be supplied on a spool ..	1 spool	2 spools

## SCALE III

## GENERAL REQUIREMENTS

The medicines and medical stores comprised in this Scale shall comply with the following requirements:—

(1) They shall conform to the standards and requirements of the current issue of the British Pharmacopoeia, the British Pharmaceutical Codex or the National Formulary, where those standards and requirements are applicable, and shall comply with any special requirements indicated in this Scale.

(2) Containers or wrappings of medicines shall be plainly and durably labelled to show:

- (a) the English name of the contents as set out in the first column of this Scale;
- (b) the particulars of the medicines given in the second column of this Scale printed in less prominent type than the information under (a). Where the word "POISON" is to be included with other particulars on the label it shall be printed in capital letters and either in red lettering or on a red background;
- (c) the minimum and maximum dose of the contents for an adult, as set in the British Pharmacopoeia, the British Pharmaceutical Codex, or the National Formulary;
- (d) the name and address of the supplier, which may be indicated on a separate label shall occupy not more than 25 per cent of the total label space.

(3) Labels shall be rendered resistant to moisture either by the use of an efficient label varnish which must cover the label and overlap the edges, or by the use of some alternative method the effect of which is not inferior to varnishing.

(4) The medicines and medical stores marked "(a)" need not be carried on ships which are normally within 12 hours voyage of a port.

SCALE III.—MEDICINES

Names of Medicines in English	Other particulars to be included on the label	Special information about composition, packaging, etc.	Quantity
Aromatic Spirit of Ammonia (a) Aspirin Tablets (a) Boric Acid .. Castor Oil .. Cocaine Eye-drops	Sp. Ammon. Aromat. .. Tab. Acid Acetylsalicyl., 5 gr. Acid. Boric. Cyst. .. Ricin .. .. Gutt. Cocain. et Hydrarg. Perchlor. Oleos. B.P.C. POISON.—For external use only. Directions for use. With the aid of the dropper put two drops into the eye every five minutes until the eye is insensitve. Usually three or four doses suffice. The eye should then be ready and the foreign body can be removed with a previously sterilised eye spud or other clean instrument. Afterwards an eye shade or some cover should be used for 24 hours.	— — — — To be supplied in green or amber fluted bottle with dropper attached	2 fl. oz. 200 2 oz. 8 fl. oz. 1 fl. oz.
Compound Codeine Tablets	Tab. Codein. Co. .. .. CAUTION.—It is dangerous to exceed the stated dose.	—	100
Cough Linctus ..	Linct. Scill. Opiat. .. .. CAUTION.—It is dangerous to exceed the stated dose.	—	1 pint
(a) Epsom Salts ..	Mag. Sulph. .. ..	To be supplied in 1 oz. packets	1 lb.
(a) Friars' Balsam (a) Goulard's Extract	Tinct. Benzoin. Co. .. .. Liq. Plumb. Subacet. Fort. POISON.—For external use only. For use prepare <i>Goulard's Lotion</i> by diluting two teaspoonfuls to a pint of water	— To be supplied in green or amber fluted bottles	2 fl. oz. 4 fl. oz.

SCALE III.—MEDICINES—*continued*

Names of Medicines in English.	Other particulars to be included on the label.	Special information about composition, packaging, etc.	Quantity
(a) Laudanum ..	Tinct. Opii. . . . . POISON	—	2 fl. oz.
(a) Methyl Salicylate Liniment	Lin. Meth. Salicyl. . . . . For external use only	To be supplied in green or amber fluted bottles	8 fl. oz.
Morphine Ampoules $\frac{1}{4}$ gr.	POISON . . . . .	Ampoule Syringes containing a solution of either a morphine salt equivalent to Anhydrous Morphine $\frac{1}{4}$ gr. in 1 c.c. or Papaveretum B.P.C. $\frac{1}{2}$ gr. in 1 c.c. (in screw-capped metal drums of six)	1 drum
Morphine Tablets	Tab. Morph. Hydrochlor. $\frac{1}{4}$ gr. or Tab. Morph. Sulph. $\frac{1}{4}$ gr. POISON	These tablets are for oral use and hypodermic tablets must not be supplied	6
(a) Sedative Tablets	Tab. Butobarbiton. $1\frac{1}{2}$ gr. POISON	—	50
Soda Mint Tablets	Tab. Sod. Bicarb. Co. . . . .	—	50
Soft Paraffin ..	Paraff. Moll. Flav. . . . .	—	4 oz.
(a) Sulphadimidine Tablets	Tab. Sulphadimid. 0.5 gramme. POISON	—	100
Tincture of Iodine	Liq. Iod. Mit. . . . . For external use only	To be supplied in green or amber fluted bottles	4 fl. oz.
Vegetable Laxative Tablets	Tab. Colocynth. et Jalap. Co. CAUTION.—It is dangerous to exceed the stated dose.	—	50
Zinc Ointment ..	Ung. Zinc. Oxid. . . . .	—	4 oz.

SCALE III.—MEDICAL STORES  
SUNDRIES

Article	Special Information	Quantity
(a) Antiseptic .. ..	To conform to the specification for Antiseptics given in Appendix A of this Schedule.	$\frac{1}{2}$ pint
Basin .. ..	To be of good quality enamelled iron, anodised aluminium, stainless steel or plastic minimum size 8" diameter by 4" depth, lettered "Medical"	1
Bottles—	Graduated tablespoons .. ..	3
(a) 6 oz. .. ..	Fluted poison .. ..	3
(a) 2 oz. .. ..		
Books—		
Ship Captain's .. ..		1
Medical Guide, latest edition with amendments.		
Merchant Shipping .. ..		1
Medical Scales, latest edition with amendments.		
(a) Boxes, Ointment .. ..	Nested .. ..	2 nests
(a) Corks .. ..	To fit 2 oz. bottle .. ..	6
	To fit 6 oz. bottle .. ..	6
Disinfectant .. ..	To conform to the specification for Disinfectants given in Appendix A of this Schedule	$\frac{1}{2}$ gall.
Eye Baths .. ..	To be of glass, porcelain or a plastic which is unaffected by immersion in boiling water for at least 5 minutes	2
Eye Shades .. ..	To be of cardboard .. ..	4
Finger Stalls, Leather .. ..	Assorted sizes .. ..	6
First Aid Satchel .. ..	The following to be supplied complete in a strong canvas bag with a strap for carrying:— 8 triangular bandages 4 standard dressings No. 13 2 standard dressings No. 14 1 standard dressing No. 15 $\frac{1}{2}$ lb. roll of cotton wool 6 brass, plated safety pins 2", on a card	1
Insecticide— (†)Liquid .. ..	To conform to specification given in Appendix C of this Schedule .. ..	An amount equal to 1½ gals. of diluted product
(†)Hand Sprayer .. ..	To conform to specification given in Appendix C of this Schedule .. ..	1
(a) Labels—Plain .. ..	In packets of 100 .. ..	1 pkt.
(a) Labels—Poison .. ..	In packets of 50 .. ..	1 pkt.

(†) Pre-packed press-button pressure canisters may replace wholly or in part diluted liquid insecticide. The volume of the contents of the canister shall not be less than one quarter of the volume of the diluted liquid insecticide which they replace.  
No hand sprayer need be carried if all the liquid insecticide solution is replaced by pressure canisters.

SCALE III.—MEDICAL STORES  
SUNDRIES—continued

Article	Special Information	Quantity
Measures— 2 oz. .. ..	Graduated ozs., drs., tablespoons and teaspoons (Mason's wine) unstamped. The words "ounces" and "drachms" to be marked in full or abbreviated and not to be replaced by symbols.	1
(a) 2 drachms .. ..	Government stamped, conical, glass graduated drachms. The words "drachms" and "minims" to be written in full or abbreviated and not to be replaced by symbols.	1
Safety Pins .. ..	Brass, Plated, 2"	12

SCALE III.—MEDICAL STORES  
INSTRUMENTS AND APPLIANCES

Article	Special Information	Quantity
Canvas Roll for Instruments	For use as a container for Eye Spud when carried; Forceps (Epilation, Spencer Wells'), Scissors, Clinical Thermometer.	1
Catheters— (a) Gum elastic, with olivery ends	Sizes 3, 5 and 7, one of each to be supplied with stilettes in a glass, plastic or metal container with a sprinkling of French chalk.	1 container
(a) Jacques rubber ..	Sizes 3, 5 and 7, one of each to be supplied in a glass, plastic or metal container with a sprinkling of French chalk.	1 container
(a) Eye Spud with covered point	To be of rustless and stainless steel	1
Forceps— Epilation with oblique ends for removal of splinters.	To be made of rustless and stainless steel throughout.	1 pair
Spencer Wells' 5" ..	To be made of rustless and stainless steel throughout.	1 pair
(a) Paget's Knife .. ..	To be of rustless and stainless steel throughout and to be supplied in a metal or wooden box.	1
Scissors 7" .. ..	One blade sharp-pointed and the other blunt-pointed. To be of rustless and stainless steel.	1 pair
(a) Sutures and Needles	The sutures should be of nylon or silk fitted to half curved eyeless needles with a cutting edge, size 10 or equivalent size. Each needle and suture to be sterile and closed in a sealed glass tube with a fracture scratch. Container label to give illustrated direction for breaking the tube.	2

SCALE III.—MEDICAL STORES  
INSTRUMENTS AND APPLIANCES—*continued*

Article	Special Information	Quantity
Splints— Common .. .. .	Largest size .. .. .	1 set
(a) Liston's Thigh .. .. .	.. .. .	1
Suspensory bandage with understraps—	.. .. .	1
(a) Medium .. .. .	.. .. .	1
(a) Large .. .. .	.. .. .	1
(a) Syringe, Higginson's with Enema Nozzle and Rubber Catheter.	The syringe with enema nozzle to be indelibly marked "For enema use only," and to be supplied in a box with one No. 8 Jacques rubber catheter	1
Thermometer, Clinical.	To be supplied in metal or plastic protective case, lens fronted $\frac{1}{2}$ min. and stamped N.P.L.	2
(a) Truss, elastic band type—	.. .. .	1
Single 38" .. .. .	With rat-tail pad, right .. .. .	1
Single 38" .. .. .	With rat-tail pad, left .. .. .	1
Double 38" .. .. .	With rat-tail pads .. .. .	1

SCALE III.—MEDICAL STORES  
DRESSINGS

Article <i>All materials must conform to the instruction at the commencement of Scale III</i>	Details regarding Packaging and Labelling	Quantity
Bandages—	To be supplied in metal container .. .. .	1 container
(a) Elastic Adhesive $2\frac{1}{2}$ " x 3 yds. (unstretched) Triangular, not less than 36" side, 51" base	Each bandage to be individually wrapped and labelled; measurements to be stated on label	3
W.O.W.—	Ditto .. .. .	12
1" x 3 yds. .. .. .	Ditto .. .. .	6
3" x 4 yds. .. .. .	To be supplied rolled. The packets to be labelled with the words "Cotton Wool," measurements to be stated on the label. The cotton wool to be in one continuous length as follows :—	6 pkts.
Cotton Wool—	$\frac{1}{2}$ oz. size .. .. .	6 pkts.
$\frac{1}{2}$ oz. 3" wide .. .. .	1 oz. size .. .. .	
1 oz. 4 $\frac{1}{4}$ " wide .. .. .	.. .. .	
Dressings—	Paraffin Gauze Dressing (B.P.C.). Packaging and labelling to conform to the specifica- tion given in Appendix F of this Schedule.	3 cartons
Burn and Wound .. .. .	.. .. .	

SCALE III.—MEDICAL STORES  
DRESSINGS—*continued*

Article <i>All materials must conform to the instructions at the commencement of Scale III</i>	Details regarding Packaging and Labelling	Quantity
Dressings— Standard No. 13 ..	Each dressing to be individually wrapped and labelled as follows : No. 13 Small B.P.C. Plain Wound Dressing 4" × 3" Directions.—Unwind short end of bandage. Hold short and rolled end of bandage to straighten out pad. Apply without touching sterilised pad or wound and bandage firmly	12
Standard No. 14 ..	Each dressing to be individually wrapped and labelled as follows : No. 14 Medium B.P.C. Plain Wound Dressing 6" × 4" Directions.—Unwind short end of bandage. Hold short and rolled end of bandage to straighten out pad. Apply without touching sterilised pad or wound and bandage firmly	8
Standard No. 15 ..	Each dressing to be individually wrapped and labelled as follows : No. 15 Large B.P.C. Plain Wound Dressing 8" × 6" Directions.—Unwind short end of bandage. Hold short and rolled end of bandage to straighten out pad. Apply without touching sterilised pad or wound and bandage firmly	4
Gauze— Absorbent— (a) 36" × 12" .. (a) 36" × 36" .. (a) Jaconet .. Lint—	To be supplied in packets labelled with the words "Gauze Absorbent Sterilised"; measurements to be stated on label	4 pkts. 2 pkts. 1 sq.yd.
Absorbent— (a) 6" × 12" .. (a) 12" × 12" ..	To be supplied in packets labelled with the words "Lint Absorbent Sterilised"; measurements to be stated on label	4 pkts. 2 pkts.
Boric— (a) 2" × 6" .. (a) 6" × 12" ..	To be supplied in packets labelled "Lint Boric"; measurements to be stated on label	12 pkts. 12 pkts.

SCALE III.—MEDICAL STORES  
DRESSINGS—continued

B 353

Article <i>All materials must conform to the instructions at the commencement of Scale III</i>	Details regarding Packaging and Labelling	Quantity
Plaster— Elastic Adhesive (a) 1" × 3 yds. ..	To be supplied on a spool	
Zinc Oxide 1" × 5 yds. ..	To be supplied on a spool	1 spool
		1 spool

SCALE IV

QUANTITIES

The quantities of medicines and medical stores marked "(a)" may be reduced 50 per cent for ships carrying less than six persons.

GENERAL REQUIREMENTS

1. Medicines and medical stores are to conform to the requirements of the current British Pharmacopoeia, the British Pharmaceutical Codex or National Formulary where those standards are applicable. Attention is drawn to special requirements in the dispensing of certain preparations.
2. Medicines are to be plainly and durably labelled to show :
  - (a) the English name of the contents as described in the first column of the Scale ;
  - (b) the description of the medicines given in the second column of the Scale printed in less prominent type than the information under (a). Where the word "POISON" is to be included with other particulars on the label it is to be printed thereon in capital letters and either in red lettering or on a red background ;
  - (c) the B.P., B.P.C., or N.F. minimum and maximum dose of the contents for an adult, or in other cases the instructions indicated in the Scale ;
  - (d) the name and address of the supplier—this should be indicated on a separate label which must not occupy more than 25 per cent of the total label space.
3. Labels are to be rendered resistant to moisture either by the use of an efficient label varnish which must cover the label and overlap the edges, or by the use of some alternative method the effect of which is not inferior to varnishing.
4. All articles are to be kept in a cabinet or separate compartment which should be capable of being locked ; the key to be kept in the custody of the Master.

## SCALE IV.—MEDICINES

Names of Medicines in English	Other particulars to be included on the label	Special information about composition, packaging, etc.	Quantity
Aromatic Spirit of Ammonia.	Sp. Ammon. Aromat. . . .	—	2 fl. oz.
Cocaine Eye-drops	Gutt. Cocain. et Hydrarg. Perchlor. Oleos. B.P.C. POISON.—For external use only. Directions for use :—With the aid of the dropper put two drops into the eye every five minutes until the eye is insensitive. Usually three or four doses suffice. The eye should then be ready and the foreign body can be removed with a previously sterilised eye spud, or other clean instrument. Afterwards an eye shade or some cover should be used for 24 hours.	To be supplied in green or amber fluted bottle with dropper attached.	1 fl. oz.
(a) Compound Codeine Tablets	Tab. Codein. Co. . . . . CAUTION.—It is dangerous to exceed the stated dose.	—	100
(a) Cough Linctus	Linct. Scill. Opiat. . . . . CAUTION.—It is dangerous to exceed the stated dose.	—	1 pint
(a) Soda Mint Tablets	Tab. Sod. Bicarb. Co. . . .	—	50
(a) Soft Paraffin Tincture of Iodine	Paraff. Moll. Flav. . . . . Liq. Iod. Mit. For external use only.	— To be supplied in green or amber fluted bottles.	4 oz. 4 fl. oz.
(a) Vegetable Laxative Tablets	Tab. Colocynth. et Jalap. Co. CAUTION.—It is dangerous to exceed the stated dose.	—	50
(a) Zinc. Ointment	Ung. Zinc. Oxid. . . . .	—	4 oz.

SCALE IV.—MEDICAL STORES  
SUNDRIES

B 355

Article	Special Information	Quantity
(a) Antiseptic .. ..	To conform to the specification for Antiseptics given in Appendix A.	$\frac{1}{2}$ pint
Basin .. ..	To be of good quality enamelled iron, minimum size 8" diameter by 4" depth, lettered "Medical."	1
Books— Ship Captain's Medical Guide, latest edition with amendments. Merchant Shipping Medical Scales, latest edition with amendments.	.. .. .	1
(a) Disinfectant .. ..	To conform to the specification for Disinfectants given in Appendix A.	1
(a) Eye Baths .. ..	To be of glass, porcelain or a plastic which is unaffected by immersion in boiling water for at least 5 minutes.	$\frac{1}{2}$ gall.
(a) Eye Shades .. ..	To be of cardboard .. .. .	2
(a) Finger Stalls, Leather First Aid Satchel .. ..	Assorted sizes The following to be supplied complete in a strong canvas bag with a strap for carrying (a) 8 triangular bandages. (a) 4 standard dressings No. 13. (a) 2 standard dressings No. 14. (a) 1 standard dressing No. 15. (a) $\frac{1}{2}$ lb. roll of cotton wool. 6 brass, plated safety pins 2" on a card	4
(a) Insecticide Liquid .. ..	To conform to the specification given in Appendix C.	6
Spray .. ..	To conform to the specification given in Appendix C.	1
(a) Safety Pins .. ..	Brass, plated, 2" .. .. .	1
		An amount equal to 3 gall. of the diluted product.
		12

SCALE IV.—MEDICAL STORES  
INSTRUMENTS AND APPLIANCES

Article	Special Information	Quantity
Roll for Instruments	For use as a container for Forceps (Epilation, Spencer Wells'), Scissors, Clinical Thermometer.	1
Forceps— Epilation with oblique ends for removal of splinters.	To be made of rustless and stainless steel throughout.	1 pair
Spencer Wells' 5"	To be made of rustless and stainless steel throughout.	1 pair
Scissors 7" .. ..	One blade sharp-pointed and the other blunt-pointed. To be of rustless and stainless steel.	1 pair
Thermometers— Common .. ..	.. .. ..	1 set
Thermometer, Clinical. . .	To be supplied in metal or plastic protective case, lens fronted, $\frac{1}{2}$ min. and stamped N.P.L.	2

SCALE IV.—MEDICAL STORES  
DRESSINGS

Article <i>All materials must conform to the instructions at the commencement of Scale IV</i>	Details regarding Packaging and Labelling	Quantity
Bandages— Triangular— not less than 36" side, 51" base.	Each bandage to be individually wrapped in printed paper with reference as to measurements and size	3
W.O.W.— 1" x 3 yds. ..	Each bandage to be individually wrapped in printed paper with reference as to measurements and size	12
3" x 4 yds. ..	Ditto	6
Cotton Wool— $\frac{1}{2}$ oz. 3" wide .. 1 oz. 4 $\frac{1}{4}$ " wide ..	To be supplied rolled The packets to be labelled with the words "Cotton Wool"; measurements to be stated on the label. The cotton wool to be in one continuous length as follows:— $\frac{1}{2}$ oz. size .. .. . 21"—22" 1 oz. size .. .. . 28"—30"	6 pkts. 6 pkts.
Dressings— Burn and Wound ..	Paraffin Gauze Dressing (B.P.C.). Packaging and labelling to conform to the specification given in Appendix F.	2 cartons

SCALE IV.—MEDICAL STORES  
DRESSINGS—continued

B 357

Article <i>All materials must conform to the instructions at the commencement of Scale IV</i>	Details regarding Packaging and Labelling	Quantity
(a) Dressings—continued Standard No. 13 ..	Each dressing to be individually wrapped and labelled as follows :— No. 13 Small B.P.C. Plain Wound Dressing 4" × 3"	12
(a) Standard No. 14 ..	Directions.—Unwind short end of bandage. Hold short and rolled end of bandage to straighten out pad. Apply without touching sterilised pad or wound and bandage firmly Each dressing to be individually wrapped and labelled as follows :— No. 14 Medium B.P.C. Plain Wound Dressing 6" × 4"	8
(a) Standard No. 15 ..	Directions.—Unwind short end of bandage. Hold short and rolled end of bandage to straighten out pad. Apply without touching sterilised pad or wound and bandage firmly Each dressing to be individually wrapped and labelled as follows :— No. 15 Large B.P.C. Plain Wound Dressing 8" × 6"	4
Plaster— Zinc Oxide 1" × 5 yds. ..	To be supplied on a spool .. ..	1 spool

## SCALE V

## MEDICAL STORES—SUNDRIES

First Aid Box : The following to be supplied in a box capable of being locked.

- 4 Triangular Bandages.
- 4 Standard Dressings No. 13.
- 2 Standard Dressings No. 14.
- 1 Standard Dressings No. 15.
- $\frac{1}{2}$  lb. Roll of Cotton Wool.
- 6 Brass plated safety pins 2" on a card.
- Tincture of Iodine 4 fl. ozs.
- or
- Acriflavine 4 fl. ozs.

The Government Inspector of Shipping may recognise materials equivalent to Standard Dressing Nos. 13, 14 and 15, for use in Scale V only, and also substitutes for the antiseptics listed, on individual applications.

## APPENDIX A

## SPECIFICATION OF DISINFECTANTS AND ANTISEPTICS FOR SHIPS

## 1. DISINFECTANTS

The disinfectant shall conform to the following specification :—

(1) *General Description.*—The disinfectant shall be a white fluid and shall be a finely dispersed, stabilized emulsion containing coal-tar acids or other phenolic bodies, with or without hydrocarbons.

(2) *Germicidal Value and the Method of its Determination.*—The germicidal value shall be not less than 1.7 when determined by the modified Chick-Martin method as laid down by the British Standards Specification No. 808 of 1938.

(3) *Stability before dilution.*—On standing for three months at ordinary temperatures (5° C. to 30° C.) the disinfectant fluid shall not precipitate nor show separation of more than traces of oil. A creamed fluid which can be rendered homogeneous by gentle mixing is permissible.

(4) *Stability after Dilution.*—The disinfectant fluid shall be miscible with distilled water and artificial sea-water (27 grammes of sodium chloride and 5 grammes of crystalline magnesium sulphate ( $MgSO_4 \cdot 7H_2O$ ) dissolved in and made up to 1,000 ml. with distilled water and filtered before use) in all proportions from one to five per cent., inclusive, to give a stable emulsion which shall not break nor show more than traces of separation of either top or bottom oil, when maintained at 18-22° C. for six hours. When examining the disinfectant under this sub-paragraph, the sample and diluent shall each be brought to the specified temperatures before mixing, which shall be performed by pouring the former into the latter from a cylinder.

(5) *Odour and Corrosive Action.*—The fluid shall be free from objectionable smell, and when used as directed, shall have no more corrosive action on metals than that occasioned by the water employed as a diluent.

(6) *Packaging.*—Where no container is specified on the tender form, the fluid shall be packaged in containers capable of being stored under normal conditions for six months without deleterious interaction between the fluid and the container.

(7) *Labelling*.—The containers shall be labelled to show the name and nature of the contents and with full instructions for use for various purposes. The dilutions recommended in the instructions shall be suitable for the purposes specified. The labels shall be rendered resistant to moisture either by the use of an efficient label varnish which must cover the label and overlap the edges or by some alternative method the effect of which is not inferior to varnishing.

## 2. ANTISEPTICS

The Antiseptic shall conform to the following specification :—

(1) *General Description*.—The antiseptic shall consist of a homogeneous solution or emulsion of a phenol, chloro-cresol, p-chloro-m-xylene or a solution or emulsion of any other germicidal substance which is no less efficient as an antiseptic, dissolved in a suitable solvent.

(2) *Phenol coefficient*.—The Rideal-Walker Phenol Coefficient of a homogeneous solution or emulsion of a phenol, chlorocresol or p-chloro-m-xylene shall not be less than 3 when determined by the method given in British Standard Specification No. 541 of 1934 as amended in August 1943, May 1951 and May 1953.

(3) *Stability of Dilution*.—The antiseptic shall not show any separation after six hours when mixed, in all proportions from one to four per cent inclusive, in waters of all degrees of hardness up to the equivalent of 300 parts calcium carbonate per million. These mixtures shall not break or precipitate in less than 6 hours at 32° C. and 37° C.

(4) *Labelling*.—The Containers shall be labelled to show the name and nature of the contents and with full instructions for use for various purposes. The dilutions recommended in the instructions shall be suitable for the purposes specified. The labels shall be rendered resistant to moisture either by the use of an efficient label varnish which must cover the label and overlap the edges or by some alternative method the effect of which is not inferior to varnishing.

## APPENDIX B

### SPECIFICATION OF ANTI-V.D. OUTFIT

1. The Anti-V.D. Outfit shall comprise a tube of prophylactic ointment and a washing cloth to the following specifications :

#### ANTI-V.D. OINTMENT

#### Formula :

Mercurous chloride	30 grammes
Sulphathiazole	15 grammes
White soft paraffin	40 grammes
Light liquid paraffin	14 grammes
Cetyl alcohol	1 gramme
Oil of Lavender	0.01 millilitre

The ointment shall be supplied in collapsible tubes, with elongated nozzles and screw caps, each containing 60 grains, and labelled Prophylactic Ointment. The length of the nozzle shall not be less than  $\frac{1}{2}$  inch nor more than  $\frac{3}{4}$  inch.

## 2. WASHING CLOTH

This cloth shall be of coarse weave soft cotton wash cloth, free from size or dressing, or white lint, and not less than 3" x 3" square impregnated with soap to a total weight of approximately 10 ounces per square yard. Soap shall be of the type that will lather in either hard or soft water. As an alternative to soap a suitable synthetic detergent, to give a washing cloth not inferior in any respect to a washing cloth prepared with soap, may be used, provided that the detergent employed is not an irritant to the skin.

3. Each kit to be in a separate sealed waterproof envelope bearing the following instructions:

## ANTI-V.D. OUTFIT

*Instructions for use after exposure*

1. Pass water.
2. Wet the wash cloth and thoroughly wash the penis, purse and surrounding skin.
3. Squeeze about  $\frac{1}{4}$  of the contents of the tube into the canal of the penis. Massage gently with thumb and forefinger for a few seconds after injecting the ointment.
4. Rub the rest of the ointment over the entire length of the penis, purse and adjacent abdomen and thigh for at least 3 minutes paying particular attention to the foreskin, head and neck of penis.
5. Do not pass water for two hours after using the kit if you can avoid it.

## APPENDIX C

## SPECIFICATION OF INSECTICIDES AND HAND SPRAYER

## 1. INSECTICIDES

The insecticide shall be capable of destroying all types of insects including, for example, mosquitoes, cockroaches, steam flies, bugs, fleas, lice and ants, commonly found in the living accommodation and in galleys or other spaces used in the preparation, or for storage, of foodstuffs for consumption on board ship.

The active principle in any insecticidal formulation shall consist of any one or more of the following—DDT, Gamma BHC, Dieldrin, Malathoin, Diazonon. Any other substance may be included in the active principle if it is no less efficient as an insecticide. The formulation may include pyrethrins or other biological equivalent.

## 2. FORMULATION

(1) The insecticide shall take the form of either—

(a) A solution of one or more insecticides in odourless petroleum distillate for use with a hand operated spray gun, complying with the provisions of paragraph 5 of this Appendix, as a space spray and residual spray.

(b) A solution of the insecticide with an appropriate propellant in a pre-packed press-button pressure canister for use as a space spray and residual spray.

(2) The insecticide in the concentration employed shall not be harmful to humans when used in accordance with the instructions and with the precautions specified on the container. The formulation shall be free from visible impurities, foreign matter and offensive odour, and shall be non-staining.

## 3. INFLAMMABILITY

The insecticide solution referred to in paragraph 2 (1) (a) and (b) of this Appendix shall not have a flash point lower than 120° F when tested by the approved Abel method.

## 4. PACKING, LABELLING AND STORAGE

(1) The insecticide solution shall be carried in containers so sealed that they will remain air-tight and water-tight. Pressure canisters for spraying shall be provided with a cap or other effective means of protecting the valve mechanism when not in use.

(2) Containers and pressure canisters shall be safely and securely packed in wooden or fibreboard cases.

(3) Containers and pressure canisters shall bear a moisture-proof label. The label may be printed on the container, and shall show at least the following items:—

(a) the name of the manufacturer ;

(b) clear instructions for use as—

(i) a residual spray against non-flying insects including for example cockroaches, steam flies, ants, bugs, fleas ;

(ii) a space spray against flying insects including for example mosquitoes, and flies ;

(c) a precautionary notice indicating that—

particular care should be taken to avoid contamination of foodstuffs, food utensils and benches on which food is prepared ; excessive inhalation of the mist should be avoided ; spillage on the skin should be washed off immediately with soap and water ; storage should be away from living accommodation, pantries, food stores and edible cargo.

## 5. SPRAYERS

The hand sprayer for use with the liquid insecticide solution, if carried, shall be a soundly constructed continuous action sprayer, the nozzle of which shall be capable of producing a fine mist and also of wetting a surface when operated close to it for the purpose of residual spraying.

## 6. INSECTICIDAL DUSTING POWDER

This shall be suitable for application to the body or clothing of infested persons. The material shall consist of a powder, white to cream, or grey in colour, containing an insecticide suitable for the purpose, packed in a dredger. Instructions for use shall be given on a moisture proof label fixed on the container or printed thereon.

## APPENDIX D

## SPECIFICATION OF OXYGEN THERAPY EQUIPMENT FOR USE ON BOARD SHIPS

1. Three disposable oxygen inhalers of plastic material.
2. One manometer type oxygen Flowmeter.
3. One fine adjustment valve with oxygen pressure gauge, bullnosed fitting.
4. 6 ft. Plastic or Rubber tubing.
5. One Oxygen Universal cylinder key which provides a lever for tightening fly-nut of bullnosed valve unions and spanners for the union nuts of fine adjustment valves, also gland nuts of bullnose type oxygen cylinder valves, chromium finish.
6. The above equipment shall be contained in a durable carrying case including simple instructions in use of equipment.

## APPENDIX E

SPECIFICATION OF CHLORIDE OF LIME FOR THE TREATMENT  
OF DRINKING WATER IN SHIPS

1. The chloride of lime shall contain not less than 24 per cent and not more than 26 per cent available chlorine. It shall also contain not less than 14 per cent of free quick lime (CaO).
2. The total water existing in all forms, consisting largely, if not entirely, of the water in combination in the form of calcium hydroxide, shall not exceed 7.5 per cent.
3. The chloride of lime shall be of such stability that after passing four weeks in an oven kept at 140° F. ( $\pm 2^\circ$ ) the percentage of available chlorine shall not decrease more than 2.
4. The chloride of lime shall be put up in  $\frac{1}{4}$  lb. tins, the date of issue by the manufacturer being stamped on the base of each tin.
5. Each tin shall contain a measure, made of a material resistant to chlorine, to contain 60 grains of the powder, when full, i.e., sufficient to chlorinate approximately 200 gallons of water.
6. Each tin and contents (except the measure, which may be used again) whether partially used or not, shall be renewed within one year following the date stamped on the tin.

## APPENDIX F

SPECIFICATION OF BURN AND WOUND DRESSING—PARAFFIN  
GAUZE DRESSING (B.P.C.)

Each dressing shall measure approximately  $3\frac{3}{4}$ "  $\times$   $3\frac{3}{4}$ " and shall be packed in an individual envelope (the dimensions of which shall be not greater than  $5\frac{1}{2}$ " square) in such a manner as to allow it to retain its even impregnation. The envelope shall be made of a suitable material, preferably not more than 50 thousandths of an inch thick, shall be impermeable to moisture, free from pin holes and shall also be grease-proof. The envelope shall be hermetically sealed and remain so under all conditions of sea transport. Thirty-six envelopes shall be packed in a suitable carton appropriately labelled, giving detailed instructions for use.

## APPENDIX G

## SPECIFICATION OF A TUBULAR STEEL PATTERN STRETCHER

The stretcher shall be of the general shape shown on the following sketch and shall be formed of canvas suitably lashed to a metal frame of 1 inch diameter tubular steel. The frame shall be fitted with four metal lugs welded on, one at each end and one at the middle of each side as shown in the sketch.

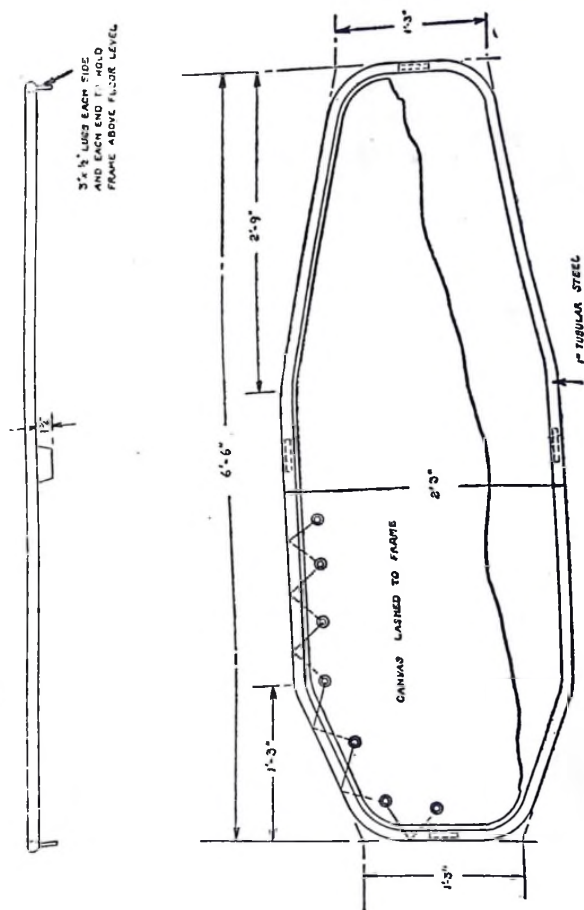

MADE at Lagos this 30th day of July, 1964.

R. A. NJOKU,  
*Federal Minister of Transport*

#### EXPLANATORY NOTE

These regulations lay down the minimum scale of medicines and medical stores to be carried by Nigerian ships.

L.N. 94 of 1964

MERCHANT SHIPPING ACT, 1962

(1962, No. 30)

**Merchant Shipping (Currency Equivalent on  
Limitation of Liability) Order, 1964**

*Commencement : 6th August, 1964*

**In exercise of the powers conferred by subsection (2) (b) of section 383 of the Merchant Shipping Act, 1962, and of all other powers, if any, enabling me in that behalf, I hereby make the following Order—**

Citation and  
application.

1. This Order may be cited as the Merchant Shipping (Currency Equivalent on Limitation of Liability) Order, 1964, and shall apply throughout the Federation.

Nigerian  
Currency  
Equivalent  
to sundry  
gold francs.

2. Seventy-three pounds eight shillings ten pence and five thirty-seconds of a penny and twenty-three pounds thirteen shillings nine pence and twenty-seven thirty-seconds of a penny are hereby specified as the amounts which for the purposes of section 383 of the Merchant Shipping Act, 1962 are to be taken as equivalent to three thousand one hundred gold francs and one thousand gold francs respectively.

MADE at Lagos this 25th day of July, 1964.

R. A. NJOKU,  
*Minister of Transport*

L.N. 95 of 1964

REMOVAL OF VEHICLES, ETC. (LAGOS) ACT, 1964  
(1964, No. II)

Removal of Vehicles (Appropriate Charges) Order, 1964

Commencement : 15th August, 1964

In exercise of the powers conferred by section 3 of the Removal of Vehicles, Etc. (Lagos) Act, 1964 and of all other powers enabling me in that behalf, I hereby make the following Order—

1. (1) This Order may be cited as the Removal of Vehicles (Appropriate Charges) Order, 1964 and shall apply to the Federal Territory of Lagos only.
- (2) This Order shall come into effect on the 15th day of August, 1964.
2. The appropriate charges to be paid in respect of all removed vehicles are as set out in the Schedule hereto.

Citation  
Applica  
and  
Comme  
ment.

Approp  
Charges  
Schedul

SCHEDULE

<i>Class of Vehicle</i>	<i>Appropriate Charges</i>
A motor vehicle which is not a Commercial Vehicle	£2-2s
A Commercial Vehicle	£4-4s

MADE at Lagos this 29th day of July, 1964.

MUSA YAR'ADUA,  
Minister of Lagos Affairs

EXPLANATORY NOTE

This Order sets out the appropriate charges payable in respect of any particular class of vehicles removed to a removed vehicle park.

L.N. 96 of 1964

REMOVAL OF VEHICLES, ETC. (LAGOS) ACT, 1964  
(1964, No. II)

Removal of Vehicles, Etc. (Lagos) Act,  
(Appointed Day) Order, 1964

Commencement : 15th August, 1964

In exercise of the powers conferred by subsection 2 of section 7 of the Removal of Vehicles, Etc. (Lagos) Act, 1964 and of all other powers enabling me in that behalf, I hereby make the following Order—

1. The Removal of Vehicles, Etc. (Lagos) Act, 1964 shall come into force on the 15th day of August, 1964.
2. This Order may be cited as the Removal of Vehicles, Etc. (Lagos) Act (Appointed Day) Order, 1964.

MADE at Lagos this 29th day of July, 1964.

App  
Day

Cit

MUSA YAR'ADUA,  
Minister of Lagos Affairs

L 0242/S. 10/II

## L.N. 97 of 1964

REMOVAL OF VEHICLES, ETC. (LAGOS) ACT, 1964  
(1964, No. II)Removal of Vehicles (Reclaiming of Removed Vehicles)  
Regulations, 1964

Commencement : 15th August, 1964

In exercise of the powers conferred by section 3 of the Removal of Vehicles, Etc. (Lagos) Act, 1964 and of all other powers enabling me in that behalf, I hereby make the following regulations—

Citation,  
application  
and com-  
mencement.

1.—(1) These regulations may be cited as the Removal of Vehicles (Reclaiming of Removed Vehicles) Regulations, 1964 and shall apply to the Federal Territory of Lagos only.

(2) These regulations shall come into effect on the 15th day of August, 1964.

Interpreta-  
tion.

2. In these regulations, unless the context otherwise requires "Official in charge of a Removed Vehicles Park" means the City Treasurer appointed by the Lagos City Council or any Officer or Servant of the Council acting under his general or specific instructions ;

"Owner" and "Dealer" have the meanings respectively assigned to them under the Road Traffic Act.

Evidence of  
entitlement  
to custody.

3.—(1) Any person claiming to be entitled to reclaim a removed vehicle shall tender to the official in charge of the removed vehicle park satisfactory evidence to the following effect :—

(a) that he is the owner of the removed vehicle at the time it was removed ; a person registered as the owner of a vehicle in accordance with the provisions of the Road Traffic Act shall be presumed to be the owner thereof ;

or

(b) that he is a driver in the service of the owner of the removed vehicle ;

or

(c) that he is entitled to the benefit of a charge or lien on the removed vehicle ;

or

(d) that he is an accredited dealer in the removed vehicle ;

or

(e) that while not being the owner of the removed vehicle, he was in possession and control thereof with the consent of the owner or other person entitled to possession thereof.

(2) Nothing in this regulation shall preclude the official in charge of a removed vehicle Park from asking for proof of the identity of any claimant.

Tender of  
appropriate  
charges.  
Schedule  
Form A.

4. The Claimant shall tender to the Official in charge of the removed vehicle Park the appropriate charge in respect of the removed vehicle as set out in the Removal of Vehicles (Appropriate Charges) Order, 1964 and shall also tender to him a receipt for the removed vehicle as in form A in the Schedule to these regulations.

Delivery of  
removed  
vehicle to  
claimant.

5. The Official in charge of the removed vehicle Park shall, upon receipt of evidence of entitlement to custody of a removed vehicle, the appropriate charge therefor and of the requisite receipt for the vehicle, deliver the said vehicle to the claimant.

SCHEDULE

FORM A

*Removal of Vehicle (Reclaiming of Removed Vehicles)  
Regulations, 1964*

*Regulation 3*

To the Official in Charge of a removed Vehicle Park,  
Lagos City Council,  
Lagos.

Dear Sir,

I/We acknowledge the receipt from the Lagos City Council of the following removed vehicle :—

Type :

Make :

Registration Mark :

2. I/We hereby indemnify the Council against any subsequent claim that may be brought by any other person as owner of the said vehicle.

Yours faithfully,

Name : .....  
(To be written in BLOCK CAPITALS)

Occupation : .....

Address : .....

Usual Signature : .....

Witness to Mark :

Name : .....  
(To be written in BLOCK CAPITALS)

Occupation : .....

Address : .....

Usual Signature : .....

MADE at Lagos this 29th day of July, 1964.

MUSA YAR'ADUA,  
Minister of Lagos Affairs

EXPLANATORY NOTE

These regulations prescribe the evidence which is required of any person claiming to be entitled to the custody of a removed vehicle.

L.N. 98 of 1964

MERCHANT SHIPPING ACT, 1962  
(1962, No. 30)

**Merchant Shipping (Restricted Commencement)  
Notice 1964**

In exercise of the powers conferred by subsection (2) of section one of the Merchant Shipping Act, 1962, and of all other powers enabling him in that behalf, the Minister of Transport has appointed the 1st day of April, 1963, as the date on which the following provision of the Merchant Shipping Act, 1962 shall come into operation—

Parts II, III, IV (excluding section 145 thereof) V, VI, VII, VIII, X, XI (excluding subsection (6) (a) of section 383 thereof) XII and XIII.

2. The Notice published as L.N. 37 of 1963 in Gazette No. 16 of 21st of March, 1963, is hereby cancelled.

L.N. 37  
of 1963.

MADE in Lagos this 31st day of July, 1964.

T1926/II

H. A. EJUEYITCHIE,  
*Permanent Secretary,  
Federal Ministry of Transport*

L.N. 99 of 1964

NAVY ACT  
(1964, No. 21)

**The Navy Act (Commencement) Order, 1964**

In exercise of the powers conferred on him by subsection (1) of Section 216 of the Navy Act and of all other powers enabling him in that behalf, the President has made the following Order—

1. The Navy Act, 1964 shall be deemed to have come into force on the 7th day of May, 1964.
2. This Order may be cited as the Navy Act (Commencement) Order, 1964.

MADE this 17th day of August, 1964.

Nb/3.Sec./Vol. III

R. C. ONYEJEPU,  
*Acting Deputy Secretary to the  
Council of Ministers*

Commence  
ment.  
Citation.



L.N. 100 of 1964

NATIONAL PROVIDENT FUND ACTS 1961 AND 1964

(1961, No. 20 AND 1964, No. 17)

National Provident Fund (Advisory Council Membership)

(Amendment) Order 1964

Commencement : 4th August, 1964

In exercise of the powers conferred by subsection (1) of section one of the National Provident Fund Act, 1964, and of all other powers, enabling me in that behalf, I hereby make the following Order.

1. This Order may be cited as the National Provident Fund (Advisory Council Membership) (Amendment) Order 1964 and shall apply throughout the Federation.

Citation and application.

2. The First Schedule to the National Provident Fund Act 1961 which provides for the constitution etc. of the National Provident Fund Advisory Council is amended—

Amendment of membership etc.

(1) (i) by substituting in paragraph 1

(a) the word "six" in subparagraph (a) for the word "five" ;

(b) the word "four" in subparagraph (b) for the word "three", and

(c) the word "six" in subparagraph (d) for the word "five" ;

(ii) by substituting in paragraph 2 the word "four" for the word "three" ;

(iii) by substituting in paragraph 4 of the word "six" for the word "five"

and accordingly

(2) by substituting in paragraph 8

(a) in respect of the quorum for any meeting, the word "nine" for the word "seven" and

(b) in the last sentence, the word "six" for the word "five".

MADE in Lagos this 4th day of August, 1964.

NPF.Rb/14/20

J. M. JOHNSON,  
Federal Minister of Labour



The following Bills, which will in due course be presented to Parliament for enactment, are published for general information.

## LAGOS LOCAL GOVERNMENT BILL

### EXPLANATORY MEMORANDUM

The purpose of this Bill is to amend a few sections of the Lagos Local Government Act, 1959. The amendments affect the preparation of voters lists, the acceptance and administration of property by the Lagos City Council for public purposes and the definition of authorised expenditure.

The Bill also contains sundry adaptations to the principal Act made necessary by the present Constitution of the Federation.

MUSA YAR'ADUA,  
*Minister of Lagos Affairs*

### ARRANGEMENT OF CLAUSES

*Clause*

1. Additional powers in relation to the lists of voters.
2. Restriction on power to acquire etc. certain property.
3. Extended meaning of authorised expenditure.

4. Miscellaneous amendments.
5. Powers validly exercised.
6. Short title, citation, etc.

SCHEDULE—Miscellaneous amendments.



# A BILL

FOR

AN ACT TO AMEND THE LAGOS LOCAL GOVERNMENT ACT 1959 ; AND TO ADAPT SUCH ACT IN CONFORMITY WITH THE CONSTITUTION OF THE FEDERATION

[ ] Commence-  
ment.

BE IT ENACTED by the Legislature of the Federation of Nigeria in this present Parliament assembled and by the authority of the same as follows :—

5 1. In the course of preparation of the official lists of voters for the purposes of an election of the Council under the provisions of the Lagos Local Government Act 1959 (in this Act hereafter referred to as the principal Act), where—

10 (a) the name of any person has been omitted from, or is inaccurately stated in, any preliminary list that person shall, when making a claim in the prescribed form, give such additional information as to his name, address or occupation as the returning officer may reasonably require to complete the official lists ;

15 (b) any person qualified under the principal Act to do so, gives notice in the prescribed form of objection to the inclusion to the preliminary list of the name of any other person, he shall send the notice of objection by registered post ;

20 and the rules referred to in section eighteen of the principal Act and contained with sundry prescribed forms in the First Schedule to that Act, shall in any such case be read and construed so as to give effect to this section accordingly.

25 2. Where the Council is empowered to accept, hold and administer property for public purposes, the power shall not be deemed to authorise the acceptance, holding or administration of property which is subject to any religious or charitable trust, and section ninety-three of the principal Act (which authorises acceptance etc. of property for public purposes) shall be so construed and have effect.

30 3. The Fourth Schedule to the principal Act (which relates to sundry special and general purposes of expenditure) is amended by the insertion immediately after item 10, of the following new items—

“11. Advances for the purchase of motor vehicles, motor cycles and bicycles to officers of the Council for the efficient performance of their duties.

“12. Advances to officers of the Council under the staff housing scheme of the Council.

35 “13. Allowances to officers and members of the Council for attendance at any conference or meeting of a joint committee, joint board, joint authority or other similar organisation.”

4. The principal Act is further amended to the extent set out in the Schedule to this Act.

Additional powers in relation to the lists of voters.  
1959 Reprint p. D 199.

Restriction on power to acquire etc. certain property.

Extended meaning of authorised expenditure.

Miscellaneous amendments.

lance of doubt that the amend-  
s they affect or relate to any of  
ive effect notwithstanding any  
e hundred and eighty-three of 5

s the Lagos Local Government  
al Act, as affected by the City of  
as the Lagos Local Government  
deral territory. 10

SCHEDULE Section 4  
s Amendments

wn" where it twice occurs there shall be

ords "the Governor-General" there shall  
in the case of a federal trunk road or  
ise,"

al sequence the following definition—  
inister of Lagos Affairs ;

-ernor-General in Council" there shall be  
sters"

~~G~~overnor-General in Council" where it  
~~e~~ shall be substituted the word "Minister"

~~G~~overnor-General in Council" where it  
~~s~~ubstituted the word "Minister"

~~p~~aragraph (e) to Crown land there shall be  
~~t~~e land

~~G~~overnor-General in Council" where it  
~~s~~ubstituted "Minister"

~~en~~ncement up to "Lagos" shall be repealed  
"There may, in and for the city of Lagos,  
uthority, by notice in the Gazette"

SCHEDULE—*continued**Section 9A*

(a) For the words "Governor-General" there shall be substituted the word "Minister"

(b) For the avoidance of doubt it is declared that the word "Municipal" where it occurs in paragraphs (b) and (c) is affected by the provisions of the City of Lagos Act 1963 and the word "city" is accordingly substituted therefor in those paragraphs

*Section 13*

For "Governor-General" where it occurs therein there shall be substituted the words "Council of Ministers"

*Section 14*

For the expression "Governor-General in Council" there shall be substituted "President of the Republic"

*Section 15*

For the expression "Governor-General in Council" where it occurs therein there shall be substituted "Minister"

*Section 17*

In subsection (1) in paragraph (b) there shall be substituted for the words "British subject or a British protected person" the words "citizen of Nigeria"

In subsection (2) in paragraph (b) all words after "has" where it first occurs up to "jurisdiction" shall be omitted.

*Section 19*

(a) All words from the commencement up to "appoint" shall be repealed and there shall be substituted "There may for the purposes of an election under this Act be appointed": and

(b) In paragraph (d) thereof for the expression "Governor-General in Council" there shall be substituted the word "Minister"

*Section 20*

All words from the commencement up to "arise and" shall be repealed and there shall be substituted the words "There shall also be appointed a chief registration officer and a returning officer as occasion may arise and any such appointment"

*Section 27*

In paragraph (a) there shall be substituted for the words "British subject or British protected person" the words "citizen of Nigeria"

*Section 31*

In subsection (3)—

(a) in paragraph (c) all words after "peace" up to the end of the paragraph shall be repealed, and

(b) paragraph (e) shall be omitted.

-continued

words of the proviso after "any  
the words "of the armed forces of  
any emergency, and any other  
of Nigeria in connection with  
the opinion of the Minister to  
on account of absence, shall  
if the failure of any such person  
ue to such employment with the  
ia, as the case may be."

eneral in Council" there shall be

(iii) there shall be substituted for

ccountants" up to the end of the

be substituted for the words "eight  
out the" the words "nine hundred  
ior"

eneral" where they twice occur there  
e Commission of the Federation"

be substituted for "the Governor-  
inister"

be substituted for "Governor-General  
of Ministers"

is "Governor-General" there shall be  
, and

ter "from any" up to "Council" shall  
ubstituted the words "State lands set  
public".

ession "Governor-General in Council"  
"Minister"

SCHEDULE—*continued*

*Section 93A*

In subsection (5) for "Governor-General" there shall be substituted "Minister"

*Section 94*

In subsection (1) for the expression "Governor-General in Council" there shall be substituted "Council of Ministers"

*Section 101*

For the expression "Governor-General in Council" where it thrice occurs there shall be substituted the word "Minister"

*Section 111*

In subsection (1) for the word "irrevocable" there shall be substituted the word "irrecoverable"

*Section 112*

In subsection (1) there shall be inserted immediately following the words "financial year" the words", or within such period as the Minister may prescribe in substitution therefor,"

*Section 115*

For the expression "Governor-General in Council" where it twice occurs there shall be substituted "Council of Ministers"

*Section 135*

In subsection (2) in paragraph (b) all words after "occupied by" up to "discretion" shall be repealed and there shall be substituted "such officers of the diplomatic corps as the Council of Ministers"

*Section 138*

In subsection (2) for "Crown" there shall be substituted "State"

*Section 140*

In subsection (13) for the expression "Governor-General in Council" there shall be substituted the word "Minister"

*Section 145*

In subsection (1) for the expression "Governor-General in Council" there shall be substituted the word "Minister"

*Section 163*

In subsection (1) in paragraph (ii) (a) there shall be substituted for "Governor-General in Council" the words "President of the Federal Republic"

*Section 172*

In subsections (1) and (2) the words "Governor-General in Council or the" shall be repealed

*Section 180*

For the word "Crown" there shall be substituted the word "State"

LE—*continued*

General in Council” where it twice  
word “Minister”

General in Council” there shall be

*one of the Lagos Local Government*

the expression “Governor-General in  
all be substituted the word “Minister”

ds “the Governor-General” there shall

nor-General” there shall be substituted

shall be inserted below “Address” at the  
pation.....”

l be inserted a new paragraph as follows—

ccount prepared by the presiding officer  
hen voting commenced and ended at his

## THE SURVEY BILL

### EXPLANATORY MEMORANDUM

The purpose of this Bill is to amend the Survey Act in order to enlarge the Surveyors Licensing Board by making provision for representations from the Regions and increasing the representation of surveyors in private practice, and also to abolish the power to license, as surveyors, persons who are not professionally qualified.

M. INUWA WADA,  
*Minister of Works and Surveys*

## A BILL

### FOR

AN ACT TO ALTER THE CONSTITUTION OF THE SURVEYORS LICENSING BOARD AND THE QUALIFICATIONS REQUIRED FOR THE ISSUE OF A SURVEYOR'S LICENCE; AND FOR PURPOSES CONNECTED WITH THE MATTERS AFORESAID.

[ ]

Commence-  
ment.

BE IT ENACTED by the Legislature of the Federation of Nigeria in this present Parliament assembled and by the authority of the same as follows:—

- 1.-(1) The Surveyors Licensing Board (hereafter in this section referred to as "the board") shall, instead of being constituted as provided by section three of the Survey Act, be constituted in accordance with the following provisions of this section; and accordingly the provisions of that section from the words "consisting of" onwards are hereby repealed.
- (2) The board shall consist of the following members, that is to say,—
- (a) the Director of Federal Surveys, who shall be the chairman of the board;
- (b) the Surveyor-General of each Region or a licensed surveyor nominated by him; and
- (c) three licensed surveyors of whom—
- (i) two shall be appointed by such body as the Minister may designate as being in his opinion representative of licensed surveyors in Nigeria; and
- (ii) the other shall be appointed by the Minister and shall be a person appearing to the Minister to be engaged in the training, at a university or school of survey in Nigeria, of persons seeking to become surveyors.

Alteration  
of constitu-  
tion of  
Surveyors  
Licensing  
Board.  
Cap. 194.

- ) A person appointed as a member of the board by virtue of paragraph (c) above—
- (b) may resign his office by notice in writing to the Minister ;
- (c) may be removed from office by the Minister for misbehaviour or inability to perform the functions of his office ; 5
- (d) shall, unless he previously resigns or is removed from office, be removed from office for such period not exceeding three years as may be specified in his instrument of appointment ; and
- (e) shall, on ceasing to hold office, be eligible for re-appointment.
- (4) The quorum of the board shall be three, and the validity of proceedings of the board shall not be affected by any vacancy in membership of the board or by any defect in the appointment of a member. 10
- (5) For the avoidance of doubt it is hereby declared that any person other than the Director of Federal Surveys) who is a member of the board immediately before the day when this Act comes into force shall cease to be such a member on that day. 15
- (6) In this section "licensed surveyor" has the same meaning as in the Survey Act.
2. No surveyor's licence shall be granted after the commencement of this Act by virtue of paragraph (c) of section five of the Survey Act (which authorises the grant of such a licence in certain circumstances to a person who has completed fifteen years service as a surveyor in the survey department of the Federation or a Region) ; and accordingly the said paragraph (c) is hereby repealed. 20 25

3. This Act may be cited as the Survey Act, 1964, and shall apply throughout the Federation.

## NEWSPAPERS (AMENDMENT) BILL

## EXPLANATORY MEMORANDUM

This Bill seeks to bring the law relating to newspapers as printed or published in Lagos more into line with newspaper legislation in operation elsewhere in Nigeria.

Clause 4 seeks to provide for matters mentioned in section 25 of the Constitution of the Federation (which relates generally to freedom of expression) and to prescribe penalties in proper cases.

T. O. S. BENSON,  
*Minister of Information*

## ARRANGEMENT OF CLAUSES

*Clauses*

- |  |  |
|--|--|
| <ol style="list-style-type: none"> <li>1. Nigerian newspapers to have offices in the Federal territory.</li> <li>2. Appointment of editor to be notified to Minister.</li> <li>3. Delivery of signed copy of newspaper by the editor.</li> </ol> | <ol style="list-style-type: none"> <li>4. Publication of certain statements, etc., an offence.</li> <li>5. Publication of name, etc. of editor in newspaper.</li> <li>6. Application of Act to editor of a government newspaper.</li> <li>7. Short title, application, etc.</li> </ol> |
|--|--|

**A BILL****FOR****AN ACT TO AMEND THE NEWSPAPERS ACT**

[ ]

BE IT ENACTED by the Legislature of the Federation of Nigeria in this present Parliament assembled and by the authority of the same as follows :—

Commence-  
ment.

5       1.—(1) The proprietor and every publisher of a newspaper printed  
territory but circulating in the Federal territory shall, within *two* months  
from the commencement of this Act, or if the newspaper first circulates  
10       months of such first circulation, establish an office for such newspaper  
Minister.

Nigerian  
newspapers  
to have  
offices in  
the Federal  
territory.

15       (2) Any other enactment to the contrary notwithstanding, it shall be  
sufficient service of any process or notice required to be served on the  
proprietor, publisher or editor of the newspaper if the process or notice  
is addressed to them or any particular one or more of them as the case  
established in the Federal territory as prescribed by this section.

20       (3) The failure to comply with the requirement of subsection (1) of  
this section shall be an offence punishable on conviction by a fine of not  
less than twenty-five pounds or more than fifty pounds, or by imprison-  
ment for a term of three months, or by both.

newspaper published in the Federal  
to have general superintendence and  
and suitable for publication in the  
the Newspapers Act (in this Act here- 5  
ct") shall be amended so as to require  
ed and sworn by the editor as is pres-  
and such affidavit shall thereafter be  
nister. The affidavit shall disclose the  
editor, and if the affidavit prescribed 10  
iled before the commencement of this  
nation as to the editor, it shall to any  
fresh affidavit made, signed, sworn and  
fter the date of such commencement.

foregoing subsection shall extend and 15  
editor for the purposes of the principal  
e of the editor, so however that if such  
fourteen days, notice in writing of the  
the person acting may be given by the  
uch notice when given shall be deemed 20  
h the requirements of section three of the

ly with the requirements of this section  
e on conviction by a fine of not less than  
than fifty pounds, or by imprisonment for 25  
both.

any other provision of the principal Act  
ed copies of a newspaper, the editor shall  
end to the Minister a copy of every news-  
t edited under his general supervision and 30  
ent the person who, under what designation  
paper shall be deemed to be acting in accor-  
matters suitable for publication given by the  
all be acting editor for the purposes of the  
and shall sign and deliver to the Minister 35  
and supplements (if any) published during

atement, rumour or report is published or  
by a person to whom this section applies 40  
or report is one which such person knows is,  
uch person publishes or reproduces it without  
ruth or falsity, and the statement, rumour or

adversely any right, reputation or freedom 45  
led to protection, or  
ial information, or  
to jeopardise the authority and independence

prejudicial to the defence of Nigeria, or to 50  
lic order, public morality or public health

any such publication or reproduction shall be an offence punishable on conviction in the case of—

- (i) a corporation, by a fine of not less than five hundred pounds, or  
 (ii) any other person, by imprisonment for a term of not less than  
 5 twelve months or more than three years.

(2) For the purposes of this section, "person to whom this section applies" includes the proprietor, editor, printer, and publisher, either jointly or severally as the case may require, and any person acting in  
 10 any such capacity, so however that where any such person is a corporation the individual so to be affixed with knowledge as aforesaid, shall be the chairman of directors, or the managing director or, as the case may be, the person in control or apparent control of the operation or operations.

(3) No prosecution shall, without the consent of the Attorney-  
 15 General of the Federation, be commenced against any person to whom this section applies or, if commenced without such consent shall be continued, in respect of anything contained in a newspaper published or circulating in the Federal territory.

(4) If the publication or reproduction relates to any matter the  
 20 publication or reproduction of which is also an offence under any other Act and the penalty prescribed therein on a conviction is less than the penalty prescribed by this section, the penalty prescribed in subsection (1) of this section shall be substituted for any such penalty; but otherwise the penalty elsewhere prescribed shall prevail.

5. Section thirteen of the principal Act is amended by the insertion  
 25 in subsection (1) immediately after the word "publisher" of the words "and of the editor in chief or editor, as the case may be".

6. In any Act other than the principal Act or this Act affixing the  
 30 responsibility of, or conferring immunity on editors, the fact that a newspaper is published in the Federal territory by or under the authority of the Government of the Federation or of a Region, as the case may be, shall be immaterial, and the definition of "newspaper" in section two of the principal Act shall be amended to the extent necessary to give effect to this section.

7.—(1) This Act may be cited as the Newspapers (Amendment)  
 35 Act, 1964 and shall be read as one with the Newspapers Act.

(2) This Act shall apply to the Federal territory.

Publication of name, etc. of editor in newspaper.

Application of Act to editor of a government newspaper.

Short title, application, etc.  
 Cap. 129.



## SUPREME COURT (AMENDMENT) BILL

## EXPLANATORY MEMORANDUM

The object of this Bill is to make better provision for the order of precedence of Justices of the Supreme Court.

T. O. ELIAS,  
*Attorney-General of the Federation  
and Minister of Justice*

## A BILL

## FOR

AN ACT TO AMEND THE SUPREME COURT ACT 1960 BY PRESCRIBING THE PRECEDENCE OF THE JUSTICES.

[ ]

Commence-  
ment.

BE IT ENACTED by the Legislature of the Federation of Nigeria in this present Parliament assembled and by the authority of the same as follows :—

5 1. The Supreme Court Act, 1960 is amended by inserting immediately after section three a new section 3A as follows :—

“3A. The Chief Justice shall take precedence of the other Justices of the Supreme Court, and the other Justices shall take precedence after the Chief Justice in accordance with the instructions of the President, acting on the advice of the Prime Minister.”

Precedence  
of the  
Justices.

10 2. This Act may be cited as the Supreme Court (Amendment) Act, 1964 and shall be read as one with the Supreme Court Act, 1960 and shall apply throughout the Federation.

(920)

Short title,  
application,  
etc.  
No. 12 of  
1960.



## NATIONAL LIBRARY BILL

### EXPLANATORY MEMORANDUM

This Bill seeks to provide for the establishment of a National Library Board which will be responsible for the running of the National Library of Nigeria. At present the National Library is administered directly as part of my Ministry, but it has been found preferable that its control should be vested in a statutory body. This is the widely used practice in the running of a library of this nature.

The success of a National Library depends largely on the amount and quality of human effort invested in it. The Board will, by the very nature of its composition as contained in the Schedule to the Bill, make it possible for supervision of the general control of the National Library to be exercised by experienced persons from relevant walks of life.

It is hoped that the National Library will be one of the symbols of the Federation, and there is therefore adequate provision in the Bill for regional representation on the proposed National Library Board.

T. O. S. BENSON,  
*Federal Minister of Information*

### ARRANGEMENT OF CLAUSES

*Clause*

- |   |   |
|---|---|
| <ol style="list-style-type: none"> <li>1. Establishment and functions of National Library Board.</li> <li>2. The director of the library.</li> <li>3. Powers of the board.</li> <li>4. Financial provisions.</li> </ol> | <ol style="list-style-type: none"> <li>5. Annual reports, etc.</li> <li>6. Furnishing of publications by government departments.</li> <li>7. Short title, extent and commencement, etc.</li> </ol> <p style="margin-top: 0;">SCHEDULE—Supplementary provisions relating to the board.</p> |
|---|---|

## A BILL

### FOR

AN ACT TO PROVIDE FOR THE ESTABLISHMENT AND MAINTENANCE OF A NATIONAL LIBRARY ; AND FOR PURPOSES CONNECTED THEREWITH.

BE IT ENACTED by the Legislature of the Federation of Nigeria in this present Parliament assembled and by the authority of the same as follows :—

[See section 7 (2)]

- 5     1.—(1) There shall be established a body, to be known as the National Library Board (and hereafter in this Act referred to as “the board”), which shall be a body corporate by the name aforesaid and shall be charged with the general functions—

10     (a) of establishing and maintaining, in accordance with the provisions of this Act, a central library for the benefit of members of the public and others ; and

Commence-  
ment.

Establish-  
ment and  
functions of  
National  
Library  
Board.

(b) of providing in accordance with those provisions such services as in the opinion of the board are usually provided by national libraries of the highest standing.

(2) For the purpose of carrying out the general functions imposed on the board by the foregoing subsection, it shall be the duty of the board, so far as its resources permit— 5

(a) to assemble, maintain and extend a collection of books, periodicals, pamphlets, newspapers, maps, musical scores, films and recordings and such other matter as the board considers appropriate for a library of the highest standing; 10

(b) to establish and maintain such branches of the library as the board considers expedient;

(c) to make the facilities of the library available to members of the public and others on proper terms (which may include provision for the payment of fees, for safeguarding the property of the board and for specifying the categories of persons who may be admitted to premises under the control of the board); 15

(d) to make such arrangements as the board considers appropriate with respect to—

(i) the exchange of matter included in the collection aforesaid; 20

(ii) the preparation and publication of catalogues, indices and similar aids; and

(iii) the provision of assistance to other persons in the organisation of libraries and with respect to the manner of using facilities under the control of libraries; and 25

(e) to make to the official in charge of any department of the government of the Federation by which a library is maintained for the purposes of the department recommendations with respect to the organisation of, and the use of facilities provided by, that library.

(3) The provisions of the Schedule to this Act shall have effect with respect to the constitution and procedure of the board and the other matters there mentioned. 30

The director  
of the  
library.

2.—(1) There shall be a director of the library (hereafter in this Act referred to as “the director”) who, subject to the provisions of subsection (2) of this section, shall be appointed by the board and shall be a person appearing to the board to have shown exceptional capacity in the organisation and administration of a library and services comparable to those envisaged by this Act. 35

(2) A person shall not be appointed as the director unless his appointment is approved by the Minister. 40

(3) The director shall hold and vacate office in accordance with the terms of the instrument by which he is appointed.

(4) The director shall, subject to any instructions given in pursuance of subsection (5) of this section, have the general function of organising and managing the library and services provided in pursuance of this Act, and in particular the function of directing the activities of the officers and servants of the board. 45

(5) The board may give the director instructions with regard to the exercise of his functions, and it shall be the duty of the director to comply with the instructions. 50

3.—(1) Subject to the following provisions of this section, the board shall have power to do anything which in its opinion is calculated to facilitate the carrying on of its activities.

Powers of the board.

(2) Except with the approval of the Minister, the board shall not have power to borrow money or to dispose of any land or minerals.

(3) Subject to the provisions of the Schedule to this Act relating to travelling and subsistence allowances, no remuneration shall be paid by the board to any member of the board other than the director.

(4) The Minister may give the board directions of a general character or relating generally to particular matters (but not to any individual person or case) with regard to the exercise by the board of its functions, and it shall be the duty of the board to comply with the directions.

4.—(1) The board shall submit to the Minister, not later than the thirty-first day of December of the year in which this Act comes into force and of each subsequent year, an estimate of its expenditure and income during the next succeeding financial year; and it shall be the duty of the director to prepare for the consideration of the board the estimates which in his opinion it would be appropriate for the board to submit to the Minister in pursuance of this subsection.

Financial provisions.

(2) The board shall keep proper accounts in respect of each financial year and proper records in relation to those accounts, and shall cause its accounts to be audited as soon as may be after the end of the financial year to which the accounts relate by a firm of auditors approved, as respects that year, by the Minister of the government of the Federation responsible for finance.

(3) The Minister may, out of moneys provided by Parliament, make to the board either by way of grant or by way of loan payments of such amounts as Parliament may from time to time determine.

5.—(1) The board shall prepare and submit to the Minister, not later than the thirtieth day of May of the year next following that in which this Act comes into force and of each subsequent year, a report in such form as the Minister may direct on the activities of the board during the last preceding financial year, and shall include in the report a copy of the audited accounts of the board for that financial year and of the auditor's report on the accounts.

Annual reports, etc.

(2) The Minister shall cause a copy of each report made to him under this section to be laid before each House of Parliament.

(3) For the purposes of the board's first report under this section, the last preceding financial year shall be deemed to include so much of any period before the beginning of that year as begins with the date of the first meeting of the board.

(4) Notwithstanding anything in subsection (4) of section three of this Act, the Minister may, by notice in writing served on the director, require the board to furnish the Minister with all information within its power relating to such matters connected with an activity of the board as may be specified by the notice; and it shall be the duty of the board to comply with the requirements of the notice.

Short title,  
extent and  
commence-  
ment, etc.

6. Where any printed matter (other than matter of such descriptions as the director may specify from time to time) is published by or on behalf of any department of the government of the Federation, it shall be the duty of the official in charge of the department to deliver forthwith to the director, for the purposes of the library maintained in pursuance of this Act, fifty copies of the publication or such smaller number of copies of the publication as the director may determine in any particular case.

5

7.—(1) This Act may be cited as the National Library Act, 1964, and shall apply to the Federal territory only.

10

(2) This Act shall come into force on such date as the Minister may by order appoint.

(3) In this Act, except where the context otherwise requires, "the Minister" means the Minister of the government of the Federation responsible for libraries.

15

## SCHEDULE

### Supplementary provisions relating to the board

Section 1.

#### *Membership of the board*

1.—(1) Subject to the provisions of this Schedule, the board shall consist of twelve members of whom one shall be the director and the others shall be appointed by the Minister and shall comprise—

(a) five persons who shall severally be persons appearing to the Minister to have wide experience of the functions of libraries in the following fields respectively, that is to say—

(i) newspapers, broadcasting and other media of mass communication ;

(ii) university education and research ;

(iii) education other than university education ;

(iv) law ;

(v) the activities of legislatures ;

(b) four persons who shall severally be persons appearing to the Minister, after consultation with such authorities of each Region as he considers appropriate in the case of each of those persons respectively, to have a wide knowledge of the requirements of that Region with respect to libraries ; and

(c) one person who shall be a person appearing to the Minister to have wide experience in the handling of financial problems connected with the provision of public services ; and

(d) one person who shall be a person appearing to the Minister to represent the interests of any body or association of librarians established in Nigeria.

(2) The Minister shall nominate one of the members of the board appointed by him to be the chairman of the board.

*Tenure of office of members*

2.—(1) Subject to the provisions of this paragraph, a member of the board shall hold office for the period of three years beginning—

(a) in the case of a member appointed to fill a vacancy which has not previously been filled, with the date of the commencement of this Act ;

(b) in any other case, with the date next following that on which the term of office of his predecessor expires by the effluxion of time or, where the predecessor has previously vacated office, on which it would have so expired.

(2) With a view to securing the retirement in rotation of members of the board, the Minister may by order provide that the term of office of any four of the persons mentioned in paragraph (a) of the foregoing subparagraph shall be one year, and that the term of office of any other four of those persons shall be two years.

(3) Where a member ceases to hold office at a time when more than three months of his term of office remain unexpired, the Minister shall as soon as may be appoint a successor who shall, subject to the following provisions of this paragraph, hold office for the residue of that term.

(4) Without prejudice to the provisions of section eleven of the Interpretation Act, 1964 (which, among other things, provides for the removal of appointees by the persons who appointed them), a member of the board shall cease to hold office if he resigns his office by a notice in writing signed by him and served on the Minister.

1964, No. 1.

(5) A person who ceases to hold office as a member of the board (other than a person who, after less than one year in office, so ceases in pursuance of subparagraph (3) of this paragraph on the expiration of the residue of his predecessor's term) shall not be eligible for reappointment as a member during the period of three years beginning with the day on which he so ceases.

(6) References in the foregoing provisions of this paragraph to members of the board do not include references to the director.

*Proceedings of the board*

3. Subject to the provisions of this Act and of section twenty-six of the Interpretation Act, 1964 (which provides for decisions of a statutory body to be taken by a majority of its members and for the chairman to have a second or casting vote), the board may make standing orders regulating the proceedings of the board or any committee thereof.

4. The quorum of the board shall be five, and the quorum of any committee of the board shall be determined by the board.

5.—(1) The board shall elect a member of the board to be the deputy-chairman of the board for such period as the board may determine, so however that a deputy-chairman who ceases to be a member shall cease to be deputy-chairman.

(2) At any time while the office of chairman is vacant or the chairman is in the opinion of the board permanently or temporarily unable to perform the functions of his office, the deputy-chairman shall perform those functions, and references in this Schedule to the chairman shall be construed accordingly.

6.—(1) Subject to the provisions of any standing orders of the board, the board shall meet whenever it is summoned by the chairman ; and if the chairman is required so to do by notice given to him by not less than six other members, he shall summon a meeting of the board to be held within seven days from the date on which the notice is given.

(2) At any meeting of the board the chairman or in his absence the deputy-chairman shall preside, but if both are absent the members present at the meeting shall elect one of their number to preside at that meeting.

(3) Where the board desires to obtain the advice of any person on a particular matter, the board may co-opt him as a member for such period as it thinks fit ; but a person who is a member by virtue of this subparagraph shall not be entitled to vote at any meeting of the board and shall not count towards a quorum.

(4) Notwithstanding anything in the foregoing provisions of this paragraph, the first meeting of the board shall be summoned by the Minister, who may give such directions as he thinks fit as to the member who shall preside and the procedure which shall be followed at that meeting.

#### *Committees*

7.—(1) The board may appoint one or more committees to carry out, on behalf of the board, such of its functions as the board may determine.

(2) A committee appointed under this paragraph shall consist of the number of persons determined by the board, and not more than one-third of those persons may be persons who are not members of the board ; and a person other than a member of the board shall hold office on the committee in accordance with the terms of the instrument by which he is appointed.

(3) A decision of a committee appointed under this paragraph shall be of no effect until it is confirmed by the board.

#### *Officers and servants*

8. Without prejudice to the generality of subsection (1) of section three of this Act but subject to the other provisions of that section, the board shall have power—

(a) to appoint such officers and servants as the board may determine ;

(b) to pay to any member or any other person appointed to a committee of the board such travelling and subsistence allowances while on any business of the board as the board may determine ;

(c) to pay to the director and to any officer or servant of the board such remuneration as the board may determine; and

(d) as regards the director and any officer or servant of the board in whose case it may determine to do so, to pay to or in respect of them such pensions and gratuities, or to provide and maintain for them such superannuation schemes (whether contributory or not), as the board may determine.

*Miscellaneous*

9.—(1) The fixing of the seal of the board shall be authenticated by the signature of the chairman or of some other member of the board authorised generally or specially by the board to act for that purpose.

(2) Any contract or instrument which, if made or executed by a person not being a body corporate, would not be required to be under seal may be made or executed on behalf of the board by any person generally or specially authorised to act for that purpose by the board.

(3) Any document purporting to be a document duly executed under the seal of the board shall be received in evidence and shall, unless the contrary is proved, be deemed to be so executed.

10. The validity of any proceedings of the board or a committee thereof shall not be affected by any vacancy in the membership of the board or committee, or by any defect in the appointment of a member of the board or of a person to serve on the committee, or by reason that a person not entitled to do so took part in the proceedings.

11. Any member of the board, and any person holding office on a committee of the board, who has a personal interest in any contract or arrangement entered into or proposed to be considered by the board or a committee thereof shall forthwith disclose his interest to the board and shall not vote on any question relating to the contract or arrangement.

(889)



## NIGERIAN RESEARCH INSTITUTES BILL

### EXPLANATORY MEMORANDUM

The objects of this Bill are firstly, to set up institutes to undertake research on cocoa, coffee, cola, oil palm, rubber and trypanosomiasis (otherwise known as sleeping sickness affecting cattle and human beings), and secondly, to wind up certain extra-territorial institutes established years ago to function in Nigeria and certain other West African countries.

The Bill makes provision for the transfer of the assets, responsibilities and operations of each of the former West African Research Institutes in Nigeria to the appropriate new institute.

WAZIRI IBRAHIM,  
*Minister of Economic Development*

### ARRANGEMENT OF CLAUSES

<i>Clause</i>	
1. Establishment and functions of research institutes.	5. Application of Pensions Act to employment in the service of institutes etc.
2. Management of affairs of institutes.	6. Annual report.
3. Financial provisions.	7. Regulations.
4. Compulsory acquisition of land for institutes.	8. Winding up of existing research institutes and their committees.
	9. Short title, extent, commencement and interpretation.
	SCHEDULE—Constitutions etc. of the councils.



# A BILL

## FOR

AN ACT TO ESTABLISH RESEARCH INSTITUTES IN RESPECT OF COCOA, COFFEE AND COLA, IN RESPECT OF THE OIL PALM, IN RESPECT OF RUBBER, AND IN RESPECT OF TRYPANOSOMIASIS ; TO PROVIDE FOR THE TRANSFER TO THOSE INSTITUTES OF CERTAIN ASSETS AND LIABILITIES OF EXISTING BODIES (IF ANY) ESTABLISHED FOR SIMILAR PURPOSES AND FOR THE WINDING UP OF THOSE BODIES ; AND FOR PURPOSES CONNECTED WITH THE MATTERS AFORESAID.

[See section 9 (2)]

Commencement.

BE IT ENACTED by the Legislature of the Federation of Nigeria in this present Parliament assembled and by the authority of the same as follows :—

- 1.-(1) There shall be established four bodies corporate by the following names, that is to say—
- (a) the Cocoa Research Institute of Nigeria ;
  - (b) the Nigerian Institute for Oil Palm Research ;
  - (c) the Rubber Research Institute of Nigeria ; and
  - (d) the Nigerian Institute for Trypanosomiasis Research,
- 10 which bodies are hereafter in this Act referred to collectively as “the institutes” and severally as “the Cocoa Institute”, “the Oil Palm Institute”, “the Rubber Institute” and “the Trypanosomiasis Institute” respectively.
- (2) The institutes shall be charged with the general duty of undertaking research into and providing information and advice relating to—
- 15 (a) the production and products of cocoa, coffee and cola in the case of the Cocoa Institute ;
  - (b) the production and products of oil palm and of such other palms as the Minister may determine in the case of the Oil Palm Institute ;
  - 20 (c) the production and products of rubber ; and
  - (d) trypanosomiasis in the case of the Trypanosomiasis Institute.
- (3) subject to the following provisions of this section, each of the institutes shall have power to do anything which, in the opinion of the institute, is calculated to facilitate the carrying on of the activities of the
- 25 institute.
- (4) Except with the prior approval in writing of the Minister, an institute shall not have power—
- (a) to incur expenditure outside approved estimates under this Act ; or
  - (b) to borrow money.
- 30 (5) The Minister may from time to time give to an institute directions of a general nature in writing with respect to the performance of its functions ; and it shall be the duty of the institute to comply with the directions.

Establishment and functions of research institutes.

- and for each institute a governing body to, in relation to the relevant provisions of the Schedule to this Act, with respect to the constitutions here mentioned. 5
- shall be managed by the council, and the provisions shall be construed accordingly; the effect of the foregoing provisions as applied to an institute shall be done by or to an institute, or by or to such person as the council as the council may determine. 10
- or instrument which, if made or executed by a body corporate, would not be made or executed on behalf of the institute or specially authorised to act for the institute. 15
- of the council of each institute—
- of research within the field for which such periods of not less than three years of approval of the Minister determine, the amount of the expenditure which will be incurred; 20
- and if necessary revise, the programme for the following year, together with the estimates for that year; 25
- and estimates of expenditure, and the programme of research approved by the Minister; 30
- Director for each institute, who shall be appointed on the advice of the council and shall be a person qualified to deal with the matters with which the relevant Director shall— 35
- to day management of the affairs of the institute with such instructions as may from time to time be given by the council; and 40
- the provisions of section five of this Act, and the provisions of the instrument by which he is appointed, as to the payment of his remuneration by the institute. 45
- shall establish and maintain a fund to which shall be credited all expenditure incurred by the institute which is not charged on the Consolidated Fund of India and is not credited to the fund— 45
- the provisions provided by Parliament as Parliament may determine; 50

(b) in the case of any institute other than the Trypanosomiasis Institute, such sums out of moneys to be provided by the legislature of each Region or by the appropriate statutory agency of each Region, in accordance with a formula agreed by the several governments and the government of the Federation ;

(c) such assets of the relevant institute and committee mentioned in section eight of this Act as are transferred to the institute in pursuance of that section ; and

(d) all other assets from time to time accruing to the institute.

(3) The fund shall be managed in accordance with rules made by the Minister and the Minister of the government of the Federation responsible for finance, acting jointly ; and, without prejudice to the generality of the power to make rules conferred by this subsection, the rules shall in particular include provision—

(a) specifying the manner in which the assets of the fund are to be held and regulating the making of payments to and from the fund ;

(b) requiring the keeping of proper accounts and records for the purposes of the fund in such form as may be specified by the rules ;

(c) for securing that the accounts are audited periodically by an auditor appointed by the Ministers aforesaid, acting jointly ;

(d) requiring copies of the accounts and of the auditor's report on them to be furnished to the Minister as soon as may be after the end of the period to which the accounts relate ; and

(e) requiring the Minister to lay before each House of Parliament copies of all accounts and reports received by him in pursuance of the last foregoing paragraph and, in the case of accounts or reports relating to the Cocoa Institute, the Oil Palm Institute, or the Rubber Institute, to send a copy to the Governor of each Region.

4.—(1) For the purposes of the Public Lands Acquisition Act, the purposes of each of the institutes shall be public purposes of the Federation within the meaning of that Act.

(2) The Chief Federal Land Officer may, by an instrument under his hand and seal, vest in the relevant institute any property acquired by the President by virtue of subsection (1) of this section ; and the institute shall pay to the Minister of the government of the Federation responsible for finance a sum equal to the aggregate amount of any expenses (including compensation) incurred on behalf of the President by virtue of the said subsection in respect of any property vested in the institute by such an instrument.

5.—(1) The Minister of the government of the Federation responsible for pensions may by order declare that the office of the director of an institute or of any person employed by an institute shall be a pensionable office for the purposes of the Pensions Act ; and any order made under an enactment repealed by virtue of this Act declaring that an office under an institute or committee abolished by virtue of this Act is a pensionable office for the purposes of that Act, or of pensions made in pursuance of this subsection, with effect from the date (if any) specified by the order, in respect of any corresponding office in the service of an institute established by this Act.

Compulsory  
acquisition  
of land for  
institutes.  
Cap. 167.

Application  
of Pensions  
Act to  
employ-  
ment in the  
service of

(2) The Pensions Act shall, in its application by virtue of the foregoing subsection to any office, have effect as if—

(a) the office were an office in the public service of the Federation within the meaning of the Constitution of the Federation;

(b) the references to the Minister of the government of the Federation responsible for pensions in paragraph (1) of section seven of that Act were references—

(i) in the case of the office of director of an institute, to the Minister; and

(ii) in any other case, to the council of the relevant institute; and

(c) section nine of that Act (which relates to compulsory retirement) were omitted.

(3) Nothing in the foregoing provisions of this section shall prevent the appointment of a person to any office on terms which preclude the grant of a pension or gratuity in respect of service in that office.

(4) So much of section seven of the Pensions Act as prevents the grant of benefits under that Act in respect of a person retiring before a specified age shall not apply in relation to the retirement of an expatriate officer within the meaning of that Act who—

(a) retires, either before or after the commencement of this Act, from an office which was or is a pensionable office by virtue of any such order as is mentioned in subsection (1) of this section; and

(b) held, on or before the first day of October, nineteen hundred and sixty-two, any such office as is mentioned in paragraph (a) of this subsection.

Annual report.

6. It shall be the duty of each of the institutes to furnish to the Minister, as soon as may be after the end of each year, a report on the activities of the institute during that year; and the Minister shall—

(a) lay before each House of Parliament a copy of each report received by him in pursuance of this section; and

(b) send a copy of each report to the Governor of each Region.

Regulations.

7.—(1) The council of each institute may make regulations generally for its purposes under this Act; and without prejudice to the generality of the foregoing, regulations may provide for the disciplinary control over the staff of the institute concerned.

(2) Regulations made under the foregoing subsection shall not have effect until they are approved by the Minister and have thereafter been published in the gazette.

Winding up of existing research institutes and their committees. Caps. 218 and 219.

8.—(1) The Minister shall by order provide for—

(a) the winding up of the affairs of the institutes and committees established by the West African Institute for Oil Palm Research Act and the West African Institute for Trypanosomiasis Research Act respectively; and

(b) the winding up as respects Nigeria of the affairs of the institute and committee regulated by the West African Cocoa Research Institute (Nigerian Status) Act, 1950,

No. 6 of 1950.

and for the transfer of the assets and liabilities of each such institute and committee as aforesaid to the corresponding institute established by this Act; but nothing in this subsection shall be construed as affecting the assets or liabilities of the institute or committee regulated by the said Act of 1950 except to the extent that they arise within Nigeria or by reason of activities carried on or formerly carried on within Nigeria.

(2) An order made in pursuance of subsection (1) of this section may contain such incidental and supplementary provisions as the Minister considers expedient for the purposes of the order.

(3) When it appears to the Minister that the affairs of any institute mentioned in paragraph (a) or (b) of subsection (1) of this section and its committee have been wound up, he shall by order declare the institute and committee to be dissolved on such day as may be specified by the order; and the order—

(a) shall include provision repealing on that day the enactments mentioned in subsection (1) of this section so far as they relate to the institute and committee dissolved by the order; and

(b) may include provision repealing or modifying any other enactment relating to that institute or committee to such extent as the Minister considers expedient in consequence of any other provision made by an order under this section.

9.—(1) This Act may be cited as the Nigerian Research Institutes Act, 1964, and shall apply throughout the Federation.

(2) This Act shall come into force on such day as the Minister may by order appoint, and a different day may be appointed in pursuance of this subsection in relation to each of the institutes.

(3) In this Act "the Minister" means—

(a) in relation to institutes other than the Trypanosomiasis Institute, the Minister of the government of the Federation responsible for agricultural research; and

(b) in relation to the Trypanosomiasis Institute, the Minister of the government of the Federation responsible for veterinary research.

Short title, extent, commencement and interpretation.

e councils

*councils*

of this Schedule, the council of eleven members and comprise—  
Minister.

Government of Western Nigeria ;  
Government of Eastern Nigeria ;  
Government of Northern Nigeria ;  
the Government of Mid-Western

this Schedule, the council of the members and comprise—  
the Minister.

the Government of Western Nigeria ;  
the Government of Eastern Nigeria ;  
the Government of Northern Nigeria ;  
the Government of Mid-Western

of this Schedule, the council of the members and comprise—  
the Minister.

the ;  
the Government of Western Nigeria ;  
the Government of Eastern Nigeria ;  
the Government of Northern Nigeria ;  
by the Government of Mid-Western

of this Schedule, the council of the consist of eleven members and com-

by the Minister.

te ;  
the Government of Western Nigeria ;  
the Government of Eastern Nigeria ;  
the Government of Northern Nigeria ;  
by the Government of Mid-Western

able for a particular institute is satisfied  
ought, by reason of their experience  
be admitted to membership he may,  
as additional members not more than  
any person so appointed under this  
etings and take part in any deliberations  
ntitled to vote thereat.

*Tenure of office of members*

2.—(1) Subject to the provisions of this paragraph, a member of a council shall hold office for the period of five years beginning—

(a) in the case of a member appointed to fill a vacancy which has not previously been filled, with the day when this Act comes into force as respects the relevant institute;

(b) in any other case, with the day next following that on which the term of office of his predecessor expires by the effluxion of time or, where the predecessor has previously vacated office, on which it would have so expired.

(2) With a view to securing the retirement in rotation of members appointed as additional members of each council, the Minister may by order provide that the term of office of any three of such members shall be such shorter period as the Minister may from time to time approve, but not less in any particular case than three years.

(3) Where a member ceases to hold office at a time when more than three months of his term of office remain unexpired, the authority who appointed him shall as soon as may be appoint a successor who shall, subject to the following provisions of this paragraph, hold office for the residue of that term.

(4) Without prejudice to the provisions of section eleven of the Interpretation Act, 1964 (which, among other things, provides for the removal of appointees by the persons who appointed them), a member of the council shall cease to hold office if he resigns his office by a notice in writing signed by him and served on the Minister.

(5) A person who ceases to hold office as a member of a council shall be eligible for reappointment as such a member.

(6) References in the foregoing provisions of this paragraph to members of a council do not include references to the director of the relevant institute.

1964, Na. 1.

*Proceedings of councils*

3. Subject to the provisions of this Act and of section twenty-six of the Interpretation Act, 1964 (which provides for decisions of a statutory body to be taken by a majority of its members and for the chairman to have a second or casting vote), each council may make standing orders regulating the proceedings of the council or any committee thereof.

4. The quorum of the council shall be five provided that at the meeting there are at least two members present to represent other governments on the council; and the quorum of any committee of a council shall be determined by the council.

5.—(1) The Minister after consultation with the Regional Governments shall appoint the chairman of a council from among its members and every council of its own motion shall elect some other member to be the deputy chairman of the council; so however that notwithstanding the period for which the appointment or election is to have effect, if a chairman or deputy chairman ceases to be a member of the council he shall cease to hold the office to which he was so appointed or elected as the case may be.

(2) At any time while the office of chairman is vacant or the chairman is in the opinion of the council permanently or temporarily unable to perform the functions of his office, the deputy-chairman shall perform those functions, and references in this Schedule to the chairman shall be construed accordingly.

6.—(1) Subject to the provisions of its standing orders, a council shall meet whenever it is summoned by the chairman; and if the chairman is required so to do by notice given to him by not less than four members of the council he shall summon a meeting of the council to be held within twenty-eight days from the date on which the notice is given. If the chairman fails to summon any meeting when so required, the Minister in his discretion may exercise such power.

(2) At any meeting of a council the chairman or in his absence the deputy-chairman shall preside, but if both are absent the members present at the meeting shall elect one of their number to preside at that meeting.

(3) Where a council desires to obtain the advice of any person on a particular matter the council may co-opt him as a member for such period as it thinks fit; but a person who is a member by virtue of this subparagraph shall not be entitled to vote at any meeting of the council and shall not count towards a quorum.

(4) Notwithstanding anything in the foregoing provisions of this paragraph, the first meeting of each council shall be summoned by the Minister, who may give such directions as he thinks fit as to the member who shall preside and the procedure which shall be followed at that meeting.

#### *Committees*

7.—(1) Each council may appoint one or more committees to carry out, on behalf of the council, such of its functions as the council may determine.

(2) A committee appointed under this paragraph shall consist of the number of persons determined by the council, and a person other than a member of the council shall hold office on the committee in accordance with the terms of the instrument by which he is appointed.

(3) A decision of a committee appointed under this paragraph shall be of no effect until it is confirmed by the council.

#### *Officers and servants*

8. Without prejudice to the generality of subsection (3) of section one of this Act but subject to subsections (4) and (5) of that section, each council shall have power—

(a) to appoint such officers and servants of the institute as the council may determine; and

(b) to pay to any officers and servants of the institute such remuneration as the council may determine.

*Miscellaneous*

9. Standing orders made by a council may provide for the payment to any member of the council or other person appointed to a committee of the council of such travelling and subsistence allowances in respect of any periods spent on the business of the council as the council may determine ; but, notwithstanding anything in section one of this Act, no other remuneration shall be paid by the council to any such member or other person.

10.—(1) The fixing of the seal of each institute shall be authenticated by the signature of the director or of some other member of the council authorised generally or specially by the council to act for that purpose.

(2) Any document purporting to be a document duly executed under the seal of an institute shall be received in evidence and shall, unless the contrary is proved, be deemed to be so executed.

11. The validity of any proceedings of a council or a committee thereof shall not be affected by any vacancy in the membership of the council or committee, or by any defect in the appointment of a member of the council or of a person to serve on the committee, or by reason that a person not entitled to do so took part in the proceedings.

12. Any member of a council or of a committee of a council who has a personal interest in any contract or arrangement entered into or proposed to be considered by the council or a committee thereof shall forthwith disclose his interest to the council and shall not vote on any question relating to the contract or arrangement.



L.N. 101 of 1964

INDUSTRIAL DEVELOPMENT (INCOME TAX RELIEF)  
ACT, 1958

**Industrial Development (Income Tax Relief)  
(Urethan Foams) Order, 1964**

*Commencement : 10th September, 1964*

WHEREAS a representation has been received pursuant to subsection (1) of section 3 of the Industrial Development (Income Tax Relief) Act, 1958 for the making of an Order declaring the industry and the products set out in the Schedule to this Order to be a pioneer industry and pioneer products :

AND WHEREAS all necessary steps have been taken pursuant to subsections (1) and (2) of section 3 of the said Act, prior to the making of this Order :

NOW THEREFORE, in exercise of the powers conferred by subsection (2) of section 3 of the Industrial Development (Income Tax Relief) Act, 1958, the President after consultation with the Council of Ministers, has made the following Order :—

1. This Order may be cited as the Industrial Development (Income Tax Relief) (Urethan Foams) Order, 1964 and shall be of Federal application.

Citation and  
application.

2. It is hereby declared that :—

(a) the industry set out in the Schedule hereto shall be a pioneer industry ; and

Declaration.

(b) the products set out in the Schedule hereto shall be the pioneer products of the industry.

SCHEDULE

<i>Industry</i>	<i>Products</i>
The manufacture of urethan foam products.	Goods made wholly or partly of urethan foams.

MADE at Lagos this 29th day of August, 1964.

I.2607

R. C. ONYEJEPU,  
*Acting Deputy Secretary to the  
Council of Ministers*

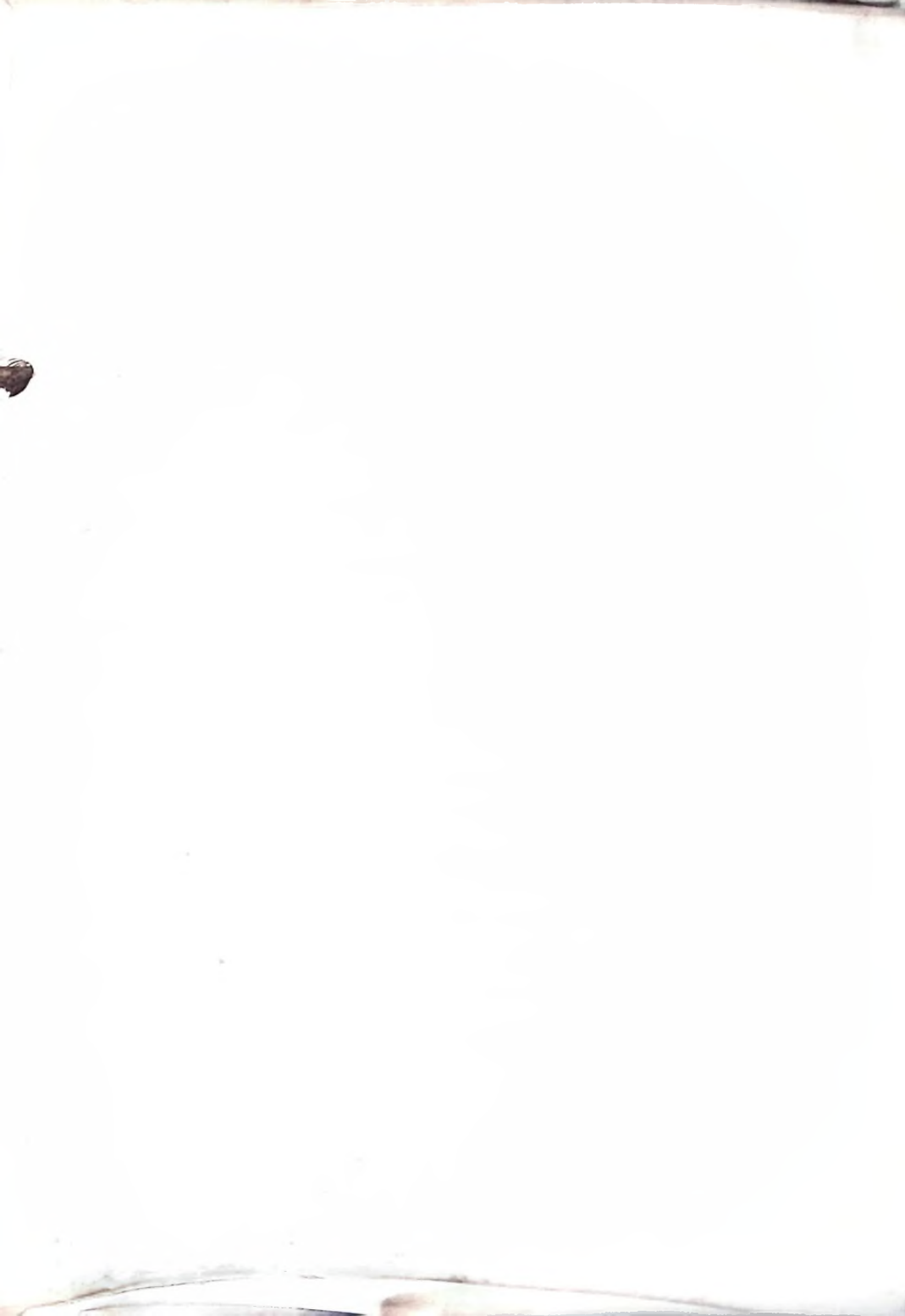

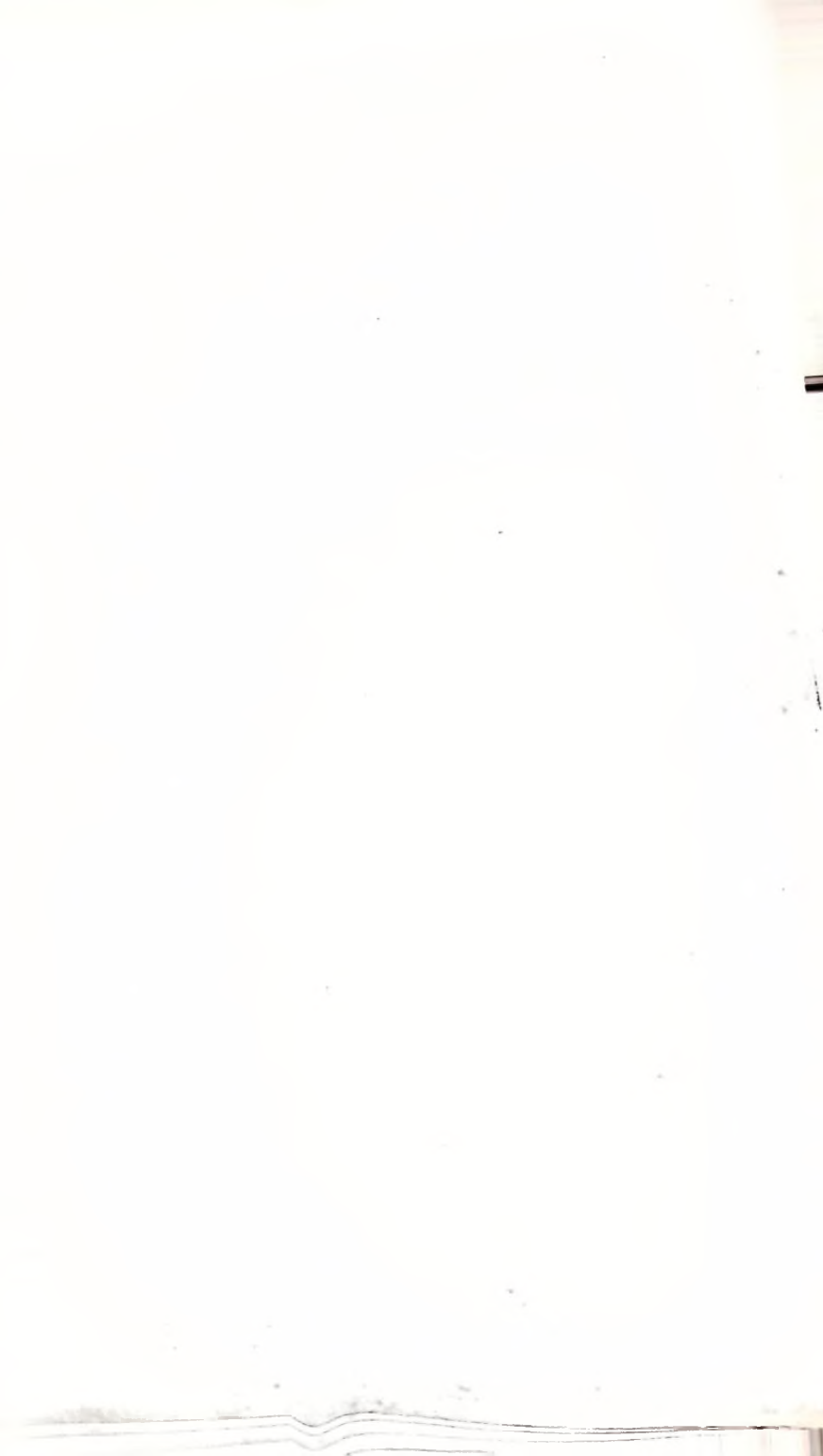

L.N. 102 of 1964

NIGERIAN COLLEGE OF ARTS, SCIENCE AND TECHNOLOGY (TRANSFER) ACT, 1962  
(1962, No. 3)

Nigerian College of Arts, Science and Technology  
(Abolition of Northern Nigeria Branch) Order, 1964

Commencement : 1st August, 1964

In exercise of the powers conferred by subsection (2) of Section 4 of the Nigerian College of Arts, Science and Technology (Transfer) Act, 1962, and of all other powers enabling me in that behalf, I hereby make the following Order—

1. The Northern Nigerian Branch of the Nigerian College of Arts, Science and Technology shall cease to exist and the College Council and any remaining Branch Committee or other committees or Board of the College shall be abolished on the 1st day of August, 1964.

Commencement.

2. This Order may be cited as the Nigerian College of Arts, Science and Technology (Abolition of Northern Nigeria Branch) Order, 1964.

Citation.

MADE this 23rd day of July, 1964.

AJA NWACHUKU,  
Federal Minister of Education

L.N. 103 of 1964

CUSTOMS AND EXCISE MANAGEMENT ACT, 1958  
(No. 55 OF 1958)

Open General Import Licence (Japan) No. 3 of 1959  
Amendment Notice, 1964

Commencement : 17th September, 1964

In exercise of the powers conferred by section 4 of the Imports Prohibition Order, 1959, the Import Licensing Authority hereby amends the Schedule to the Open General Import Licence referred to herein.

1. The Schedule to the Open General Import Licence (Japan) No. 3 of 1959 is hereby amended by the addition of the following item—

	<i>Import Group</i>	<i>Item No.</i>	<i>Amend- ment of L.N. 238 of 1959 L.N. 105 of 1963.</i>
"25. Lemon Fruit	.. .. .	051	90"

Citation  
and  
application.

2. This notice may be cited as the Open General Import Licence (Japan) No. 3 of 1959 Amendment Notice, 1964 and shall apply throughout the Federation.

MADE this 17th day of September, 1964.

J. B. ELUMEZE,  
*Import Licensing Authority,*  
*Federal Ministry of Commerce and Industry*

#### EXPLANATORY NOTE

The effect of this amendment is that specific import licence is now required for the importation of fresh lemon fruits into Nigeria while lemon juice and lemon barely water may be imported without specific import licence.

#### L.N. 104 of 1964

#### CUSTOMS AND EXCISE MANAGEMENT ACT, 1958 (No. 55 OF 1958)

#### Open General Import Licence (Dollar Area) No. 4 of 1959 Amendment Notice, 1964

*Commencement : 17th September, 1964*

In exercise of the powers conferred by Section 4 of the Imports Prohibition Order, 1959, the Import Licensing Authority hereby amends the Second Schedule to the Open General Import Licence referred to herein.

Amend-  
ment of  
L.N. 239 of  
1959.

1. The Second Schedule to the Open General Import Licence (Dollar Area) No. 4 of 1959 is hereby amended by the addition of the following item—

	<i>Import Group</i>	<i>Item No.</i>
"37 Lemon, Fruit . . . .	051	90"

Citation and  
application.

2. This notice may be cited as the Open General Import Licence (Dollar Area) No. 4 of 1959 Amendment Notice, 1964 and shall apply throughout the Federation.

MADE in Lagos this 17th day of September, 1964.

J. B. ELUMEZE,  
*Import Licensing Authority,*  
*Federal Ministry of Commerce and Industry*

#### EXPLANATORY NOTE

The effect of this amendment is that specific import licence is now required for the importation of fresh lemon fruits into Nigeria while lemon juice and lemon barely water may be imported without specific import licence.

L.N. 105 of 1964

**CUSTOMS AND EXCISE MANAGEMENT ACT, 1958**  
(No. 55 of 1958)

**Open General Import Licence (Hong Kong) No. 1 of 1963 (No. 2)**  
**Amendment Notice, 1964**

*Commencement : 17th September, 1964*

In exercise of the powers conferred by section 4 of the Imports Prohibition Order, 1959, the Import Licensing Authority hereby amends the Schedule to the Open General Import Licence referred to herein.

1. The Schedule to the Open General Import Licence (Hong Kong) No. 1 of 1963 is hereby amended by the deletion of the following item—

	<i>Import Group</i>	<i>Item No.</i>
"24. Lemon Fruit .. .. .	051	90"

Amendment of L.N. 121 of 1963 and L.N. 85 of 1964.

2. This notice may be cited as the Open General Import Licence (Hong Kong) No. 1 of 1963 Amendment (No. 2) Notice, 1964 and shall apply throughout the Federation.

Citation and application.

MADE this 17th day of September, 1964.

J. B. ELUMEZE,  
*Import Licensing Authority,*  
*Federal Ministry of Commerce and Industry*

EXPLANATORY NOTE

The effect of this amendment is that specific import licence is now required for the importation of fresh lemon fruits into Nigeria while lemon juice and lemon barely water may be imported without specific import licence.

SC411/T/9

L.N. 106 of 1964

**CUSTOMS AND EXCISE MANAGEMENT ACT, 1958**  
(No. 55 of 1958)

**Open General Import Licence (All Countries) No. 1 of 1964**  
**Amendment Notice, 1964**

*Commencement : 17th September, 1964*

In exercise of the powers conferred by Section 4 of the Imports Prohibition Order, 1959, the Import Licensing Authority hereby amends the Second Schedule to the Open General Import Licence referred to herein.

1. The Second Schedule to the Open General Import Licence (All Countries) No. 1 of 1964 is hereby amended by the deletion of the following item—

	<i>Import Group</i>	<i>Item No.</i>
"22. Lemons .. .. .	053	50"
and addition of the following item—		
"22. Lemon, Fruit .. .. .	051	90"

Amendment of L.N. 56 of 1964.

2. This Notice may be cited as the Open General Import Licence (All Countries) No. 1 of 1964 Amendment Notice, 1964 and shall apply throughout the Federation.

MADE in Lagos this 17th day of September, 1964.

J. B. ELUMEZE,  
Import Licensing Authority,  
Federal Ministry of Commerce and Industry

#### EXPLANATORY NOTE

The effect of this amendment is that specific import licence is now required for the importation of fresh lemon fruits into Nigeria while lemon juice and lemon barely water may be imported without specific import licence.

L.N. 107 of 1964

CUSTOMS AND EXCISE MANAGEMENT ACT, 1958  
(No. 55 OF 1958)

Open General Import Licence (Netherlands) No. 2 of 1964  
Amendment (No. 2) Notice, 1964

Commencement : 17th September, 1964

In exercise of the powers conferred by section 4 of the Imports Prohibition Order, 1959, the Import Licensing Authority hereby amends the Schedule to the Open General Import Licence (Netherlands).

1. The Schedule to the Open General Import Licence (Netherlands) No. 2 of 1964 is hereby amended by the deletion therefrom of the following item—

	Import Group	Item No.
"22 Lemon . . . . .	053	50
and the substitution thereto of the following item—		
"22 Lemon, Fruit . . . . .	051	90

2. This notice may be cited as the Open General Import Licence (Netherlands) No. 2 of 1964 Amendment (No. 2) Notice, 1964 and shall apply throughout the Federation.

MADE this 17th day of September, 1964.

J. B. ELUMEZE,  
Import Licensing Authority,  
Federal Ministry of Commerce and Industry

#### EXPLANATORY NOTE

The effect of this amendment is that specific import licence is now required for the importation of fresh lemon fruits into Nigeria while lemon juice and lemon barely water may be imported without specific import licence.

d-  
of  
47 of  
and  
36 of

on  
pli-

14. Subject to the provisions of paragraph 15 of this Schedule, if the spacings of the uprights or shores are less than those respectively referred to in paragraphs 3 and 12 of this Schedule the sizes of the shores may be reduced in proportion.

15. Where their angle from the horizontal does not exceed  $10^{\circ}$  the shores fitted shall be of the sizes specified in paragraph 13 of this Schedule. Where, by reason of the construction of the ship, their angle from the horizontal exceeds  $10^{\circ}$  then the next larger size of shore to that required by its length shall be fitted. In no case shall the angle between any shore and the horizontal exceed  $45^{\circ}$ .

#### STAYS

16. One stay on each side of each upright shall be fitted in holds 20 ft. and under in depth and shall be placed at a distance below the deck of approximately one-third from under deck. In holds over 20 ft. in depth two stays on each side of each upright shall be fitted the upper stays being placed at a distance below the deck of approximately one-quarter of the depth of the hold and the lower stays at half the depth of the hold. For the purposes of this paragraph depths shall be measured to top of floors, inner bottom or tunnel top, as the case may be.

17. When stays are used the following provisions shall apply:—

(a) The stays shall be of 3 in. circumference flexible steel wire rope and shall be fitted horizontally.

(b) The rigging screws shall be  $1\frac{1}{4}$  in. in diameter and shall be fitted in accessible positions.

(c) The shackles shall be 1 in.

(d) The eye bolts through the wood or angle bar uprights shall be  $1\frac{1}{4}$  in.

(e)  $\frac{3}{8}$  in. screw bolts and nuts shall be provided as may be necessary for securing the wood uprights or steel angle bars.

(f) Either eye plates of 1 in. thickness shall be securely riveted to the side stringers or frames or 1 in. shackles passed through the frame.

18. If any shifting boards do not extend to the full depth of the hold the shifting boards and their uprights shall be supported or stayed so as to be as efficient as shifting boards which extend to the full depth of the hold.

#### CONSTRUCTION OF FEEDERS BINS AND BULKHEADS

19. Feeders, bins and bulkheads shall be of sufficient strength to withstand the pressure due to the head of grain contained therein and shall be grain-tight.

20. Ships having one or more decks with any continuous hold, whether forward or aft, with two hatches to that hold shall have a well-constructed bulkhead extending from side to side of the ship between the two hatches to divide the hold.

21. Wood feeders, wing feeders and bin bulkheads shall be constructed either:

(a) of planks which have been worked vertically and which are not less than  $2\frac{1}{2}$  in. thickness; when the vertical unsupported span of the planks exceeds 8 ft. the thickness thereof shall be increased proportionately or proportional additional stiffening shall be fitted; or

(b) of framing lined with grain-tight boards 2 in. in thickness or two 1 in. layers of shiplap, laid horizontally with broken joints; the framing shall where possible be placed inside the hatch coamings and shall be not less than 4 in. x 6 in. laid on edge spaced not more than 2 ft. apart centre to centre.

The planks at the corners shall be well secured to substantial vertical cants.

22. If the depth of the hatch end beams or coamings exceeds 15 in. below the surface of the deck, feeding holes shall be provided to allow the grain to flow through the coamings into the hold or 'tween decks. When the depth of the coamings below the surface of the deck exceeds 15 in. and does not exceed 18 in. feeding holes 2 in. in diameter shall be provided. When the depth exceeds 18 in. feeding holes of 3½ in. diameter shall be provided. Feeding holes shall be spaced approximately 2 ft. apart.

23. Engine-room and stokehold bulkheads and donkey boiler recesses, where subjected to heat, shall be sheathed with wood and made grain-tight. An air space of at least 6 in. shall be left between the bulkhead and the sheathing and a box trunk ventilator 6 in. x 8 in. in size shall be supported on vertical runners spaced not less than 2 ft. apart centre to centre and shall consist of 2 in. planks or two thicknesses of 1 in. boards laid to break joint.

## STOWAGE

### *Stowage of full holds and compartments*

24. Subject to the provisions of Regulation 26, if any hold or compartment is entirely filled with bulk grain it shall be divided either by a longitudinal bulkhead, or shifting boards in line with, or not more than 5 per cent of the moulded breadth of the ship from, the centre line or by longitudinal bulkheads or shifting boards off the centre line of the ship provided that the distance between them shall not exceed 60 per cent of the moulded breadth of the ship and that in the latter case trimming hatches of suitable size shall be provided in the wings at longitudinal intervals of not more than 25 feet with end trimming hatches placed not more than 12 feet from transverse bulkheads. In every case the longitudinal bulkheads or shifting boards shall be properly constructed and fitted grain-tight with proper fillings between the beams. In holds, such longitudinal bulkheads or shifting boards shall extend downwards from the underside of the deck to a distance of at least one-third of the depth of the hold or 8 feet whichever is the greater. In compartments in 'tween decks and superstructures they shall extend from deck to deck. In all cases the longitudinal bulkheads or shifting boards shall extend to the top of the feeders of the hold or compartment in which they are situated.

Provided that in the case of ships loaded with bulk grain other than linseed in which a metacentric height (after correction for the free surface effects of liquids in tanks) is maintained throughout the voyage of not less than 12 inches in the case of one or two deck ships and not less than 14 inches in the case of other ships, longitudinal bulkheads or shifting boards need not be fitted:—

(a) below and within 7 feet of a feeder, but only in way of a hatchway, if that feeder contains, or all the feeders collectively feeding a compartment contain, not less than 5 per cent of the quantity of grain carried in the compartment which is fed;

(b) in feeders which meet the requirements of paragraph (a) of this Regulation and which have such dimensions that the free grain surface will remain within the feeders throughout the voyage after allowing for a sinkage of grain amounting to 2 per cent of the volume of the compartment fed and a shift of the free grain surface to an angle of 12 degrees to the horizontal; in this case the possible effects of the above mentioned movement of the free grain surfaces within the feeders shall be taken into account in calculating the metacentric height given above;

(c) in way of the hatchway where the bulk grain beneath the hatchway is trimmed in the form of a saucer hard up to the deckhead beyond the hatchway and is topped off with bagged grain or other suitable bagged cargo extending to a height in the centre of the saucer of not less than 6 feet above the top of the bulk grain (measured below the deck line); the bagged grain or other suitable bagged cargo shall fill the hatchway and the saucer below and shall be stowed tightly against the deckhead, the longitudinal bulkheads, the hatchway beams and, the hatchway side and end coamings.

*Stowage of partly filled holds and compartments*

25. Subject to the provisions of Regulation 26, if any hold or compartment is partly filled with bulk grain :—

(a) it shall be divided by a longitudinal bulkhead or shifting boards, in line with, or not more than 5 per cent of the moulded breadth of the ship from, the centre line or by longitudinal bulkheads or shifting boards off the centre line of the ship provided that the distance between them shall not exceed 60 per cent of the moulded breadth of the ship. In every case the longitudinal bulkheads or shifting boards shall be properly constructed and shall extend from the bottom of the hold or deck, as the case may be, to a height of not less than 2 feet above the surface of the bulk grain.

Provided that, except in the case of holds partly filled with linseed in bulk, longitudinal bulkheads or shifting boards need not be fitted in way of the hatchway in the case of ships in which a metacentric height (after correction for the free surface effects of liquids in tanks) is maintained throughout the voyage of not less than 12 inches in the case of one or two deck ships and not less than 14 inches in the case of other ships;

(b) the bulk grain shall be levelled and topped off with bagged grain or other suitable cargo tightly stowed and extending to a height of not less than 4 feet above the top of the bulk grain within spaces divided by such a longitudinal bulkhead or shifting boards, and not less than 5 feet within spaces not so divided. The bagged or other suitable cargo shall be supported on suitable platforms laid over the whole surface of the bulk grain; such platforms shall consist of bearers spaced not more than 4 feet apart and 1 inch boards laid thereon spaced more than 4 inches apart or of strong separation cloths with adequate overlapping.

*Exceptions to the requirements for longitudinal bulkheads*

26. The fitting of longitudinal bulkheads or shifting boards in accordance with the provisions of Regulations 24 and 25 shall not be required :—

(a) in a lower hold (which term also includes the lower part of the hold of a single-deck ship) if the bulk grain therein does not exceed one-third of the capacity of the hold, or where such lower hold is divided by a shaft tunnel, one-half the capacity of that lower hold;

(b) in any space in a 'tween deck or superstructure provided that the wings are tightly stowed with bagged grain or other suitable cargo to a breadth on each side of not less than 20 per cent of the breadth of the ship in way thereof; and

(c) in those parts of spaces where the maximum breadth of the deckhead within the said spaces does not exceed one-half of the moulded breadth of the ship.

#### *Feeders*

27. (a) (i) Any hold or compartment which is entirely filled with bulk grain shall be fed by suitably placed and properly constructed feeders, except as otherwise provided in paragraph (c) of Regulation 24 and Regulations 28 and 32 so as to secure a free flow of grain from the feeder to all parts of that hold or compartment.

(ii) Each feeder shall contain not less than 2 per cent of the quantity of grain carried in that part of the hold or compartment that it feeds except as otherwise provided for in paragraph (a) of Regulation 24.

(b) When bulk grain is carried in deep tanks primarily constructed for the carriage of liquids to which paragraph (c) of Regulation 26 applies or that are divided by one or more permanent steel longitudinal divisions fitted grain-tight, feeders to the tanks may be omitted if the tanks and tank hatchways are completely filled and the hatch covers secured.

#### *Common Loading*

28. For the purpose of Regulations 24 and 27 of this Chapter lower holds and 'tween deck spaces over them may be loaded as one compartment under the following conditions:—

(a) longitudinal bulkheads or shifting boards shall be fitted deck to deck in the 'tween deck of a ship having two decks; in all other cases the longitudinal bulkheads or shifting boards shall be fitted for the upper third of the total depth of the common spaces;

(b) in order to secure an adequate flow of grain all spaces shall comply with the requirements of Regulation 29 of this Chapter and openings shall be provided in the wings of the deck immediately below the uppermost deck forward and aft of the ends of the hatchways as necessary to provide in combination with the hatchways a maximum feeding distance of 8 feet measured in a fore and aft line.

#### *Trimming and bagging of end spaces*

29. When the distance, measured in a fore and aft line, from any part of a hold or compartment to the nearest feeder exceeds 25 feet the bulk grain in the end spaces beyond 25 feet from the nearest feeder shall be levelled off at a depth of at least 6 feet below the deck, and the end spaces filled with bagged grain built up on a suitable platform as required in paragraph (b) of Regulation 25.

*Bulk grain in 'tween decks and superstructures*

30. Bulk grain shall not be carried above deck, in the 'tween deck of a two deck ship, or in the uppermost 'tween deck of a ship having more than two decks except under the following conditions :—

- (a) the bulk grain or other cargo shall be stowed so as to ensure maximum stability : in all cases either a metacentric height (after correction for the free surface effects of liquids in tanks) shall be maintained throughout the voyage of not less than 12 inches in the case of one or two deck ships and 14 inches in the case of other ships or, alternatively, the aggregate quantity of bulk grain or other cargo carried above deck, in the 'tween deck spaces of a two deck ship or in the uppermost 'tween deck spaces of a ship having more than two decks shall not exceed 28 per cent by weight of the total cargo below the 'tween deck where the master is satisfied that the ship will have adequate stability throughout the voyage ; the limitation of 28 per cent specified above shall not apply when the grain carried above deck or in the uppermost 'tween deck spaces is oats, barley or cotton seed ;
- (b) the deck area of any portion of the spaces referred to in this Regulation which contains bulk grain and which is only partly filled shall not exceed 1,000 square feet ; and
- (c) all spaces referred to in this Regulation in which bulk grain is stowed shall be subdivided by transverse bulkheads at intervals of not more than 100 feet ; when this distance is exceeded the excess space shall be entirely filled with bagged grain or other suitable cargo.

*Limitation on number of partly filled holds and compartments*

31. Except in the case of ships in which a metacentric height (after correction for the free surface effects of liquids in tanks) is maintained throughout the voyage of not less than 12 inches in the case of one or two deck ships, and not less than 14 inches in the case of other ships, not more than two holds or compartments shall be partly filled with bulk grain, except that other holds or compartments may be partly filled with bulk grain if they are filled up to the deckhead with bagged or other suitable cargo. For the purpose of this Regulation :—

- (a) superimposed 'tween decks shall be regarded as separate compartments and separate from any lower hold below them ;
- (b) feeders and the partly filled spaces referred to in paragraph (b) of Regulation 30 shall not be regarded as compartments ; and
- (c) holds or compartments provided with one or more grain-tight longitudinal divisions shall be regarded as one hold or compartment.

*Stowage of specially suitable ships*

32. (a) Notwithstanding anything contained in Regulations 24 to 31, bulk grain may be carried without regard to the requirements specified therein in ships which are constructed with two or more vertical or sloping grain-tight longitudinal divisions suitably disposed to limit the effect of any transverse shift of grain under the following conditions :—

- (i) as many holds and compartments as possible shall be full and trimmed full ;

Ship will not list to an angle where:—

When trimmed full the deck surface under all boundaries at an inclination of

Deck surfaces settle down or to such larger extent Inspector of Marine with Regulation of levelled surfaces. Paragraph shifting transverse shift of the

Plan covering the vessel, both approved stability conditions (i) of this paragraph

Describe the precautions of ships designed to meet the require-

Describe the precautions which meets the paragraph (a) of this

Stability requirement in longitudinal sub-length does not

shall be well filled

the Government or by the Government of Life at Sea

*Exemptions for certain Voyages*

36. The Government Inspector of Shipping, may, if he considers that the sheltered nature and conditions of the voyages are such as to render the application of any of the requirements of Regulations 24 to 35 unreasonable or unnecessary, exempt from those particular requirements individual ships or classes of ships for voyages within Nigerian waters.

MADE at Lagos this 12th day of November, 1964.

R. A. Njoku,  
*Federal Minister of Transport*

## EXPLANATORY NOTE

These rules make provisions for precautions which are considered to be necessary or reasonable to prevent grain shifting when it is being carried in ships in any part of Nigeria.

nd

\*L.N. 126 of 1964

REGISTRATION OF TITLES ACT (CAP. 181)

Registration of Titles (Application) Order, 1964

Commencement : 9th October, 1964

In exercise of the powers conferred by subsection 1 of section 2 of the Registration of Titles Act and of all other powers enabling me in that behalf, I hereby make the following Order—

This Order may be cited as the Registration of Titles (Application) Order, 1964 and shall apply to the area specified in the Schedule hereto.

Cit=  
app=

SCHEDULE

All that parcel of land at Surulere, Yaba West, Ebute Metta West and Abule-Nla on the Mainland of the Federal Territory the boundaries of which are described below :

Starting at a concrete pillar marked LD6544 the co-ordinates of which are 5,885.15 feet south and 7,895.21 feet west of a concrete pillar marked LCS165P, the origin of Lagos Cadastral Surveys the boundaries run in straight lines, the bearings and lengths of which are as follows :—

From	Bearings	Lengths	To
LD6544	111° 22'	483.6' feet	LD6543
LD6543	111° 22'	660.0' feet	LD6542
LD6542	58° 48'	185.5' feet	C.P.
C.P.	75° 55'	44.9' feet	EA2268
EA2268	30° 34'	64.3' feet	EA2267
EA2267	36° 08'	264.7' feet	EA2266
EA2266	49° 01'	137.6' feet	EA2265
EA2265	28° 34'	82.2' feet	EA2264
EA2264	49° 51'	233.5' feet	EA2263
EA2263	341° 43'	209.7' feet	EA2262
EA2262	357° 51'	109.7' feet	EA2261
EA2261	29° 10'	179.8' feet	EA2260
EA2260	1° 24'	51.5' feet	KE364
KE364	75° 44'	4,092.2' feet	LCS1487S
LCS1487S	68° 47'	3,055.4' feet	LCS1477S

Thence southwards along Clifford Street to Lagos Street; thence westwards (into the Railway Compound) on a bearing of 245° 00' for a distance of 1,074 feet; thence on a bearing of 156° 15' for a distance of 346 feet; thence on a bearing of 244° 30' for a distance of 706 feet to Thomas Street; thence along Thomas Street on a bearing of 156° 00' for a distance of 348 feet to PBL 2311 on its junction with Ibadan Street West; thence along Ibadan Street West on a bearing of 244° 00' for a distance of 350 feet; thence along Babani Street on a bearing of 155° 00' for a distance of 338 feet to a concrete pillar marked PBL 3860; thence on a bearing of 164° 12' for a distance of 17.0 feet to PBL 3859 on the junction of Apapa Road with

Babani Street; thence westwards along Apapa Road to its junction with Western Avenue; thence westwards along Apapa Road to its junction with Abebe (Iganmu) Road level crossing. Thence along Abebe (Iganmu) Road to a concrete pillar marked LCS 552P

From	Bearings	Lengths	To
552P	269° 40'	232.2 feet	553P
553P	296° 44'	598.0 feet	544P
554P	276° 20'	252.5 feet	555P
555P	245° 18'	266.4 feet	556P
556P	263° 21'	179.9 feet	557P
557P	248° 43'	168.5 feet	558P
558P	282° 57'	188.3 feet	559P
559P	293° 05'	275.2 feet	560P
560P	268° 21'	260.2 feet	561P

Thence southwards on a bearing of 180° 00' and an approximate distance of 671.5 feet to the edge of the swamp. Thence along the edge of the swamp in a zig-zag direction to a point P61 on the Federal Territory boundary.

From	Bearings	Lengths	To
P61	0° 00'	533.7 feet	PBC3646
PBC3646	0° 00'	1,058.1 feet	PBC3645
PBC3645	0° 00'	444.1 feet	PBC3644
PBC3644	0° 00'	1,229.4 feet	PBC3643
PBC3643	0° 00'	899.7 feet	LCS465P
LCS465P	0° 00'	292.1 feet	LCS464P
LCS464P	0° 00'	340.0 feet	LCS463P
LCS463P	0° 00'	580.5 feet	LD6544 (the starting point).

MADE in Lagos this 4th day of November, 1964.

MUSA YAR'ADUA,  
Minister of Lagos Affairs

#### EXPLANATORY NOTE

This Order extends the application of the Registration of Titles Act to certain parts of the Lagos Mainland not already within the ambit of the Act.

\*NOTE:—The above Legal Notice cancels L.N. 126 of 1964 published in the Supplement to the Federal Republic of Nigeria Official Gazette No. 91, Vol. 51 of 12-11-64.

L.N. 128 of 1964

INDUSTRIAL DEVELOPMENT (INCOME TAX RELIEF) ACT  
(CHAPTER 87)

Industrial Development (Income Tax Relief)  
(Dry Cell Batteries) Order, 1964

Commencement : 16th November, 1964

WHEREAS a representation has been received pursuant to subsection (1) of section 3 of the Industrial Development (Income Tax Relief) Act for the making of an Order declaring the industry and the product set out in the Schedule to this Order to be a pioneer industry and pioneer product :

AND WHEREAS all necessary steps have been taken pursuant to subsections (1) and (2) of section 3 of the said Act, prior to the making of this Order :

NOW THEREFORE, in exercise of the powers conferred by subsection (2) of section 3 of the Industrial Development (Income Tax Relief) Act, and of all other powers enabling him in that behalf, the President hereby makes the following Order :—

(1) This Order may be cited as the Industrial Development (Income Tax Relief) (Dry Cell Batteries) Order, 1964 and shall be of Federal application.

Citation and application.

(2) The industry and its product set out in the Schedule hereto are hereby declared as a pioneer industry and a pioneer product respectively.

Declaration of pioneer industry and pioneer product.

SCHEDULE

<i>Industry</i>	<i>Product</i>
The manufacture/assembly of dry cell batteries	Dry Cell Batteries

MADE this 16th day of November, 1964.

R. C. ONYEJEPU,  
Acting Deputy Secretary to the  
Council of Ministers

EXPLANATORY NOTE

The purpose of this Order is to declare the manufacture and assembly of dry cell batteries and its product pioneer industry and pioneer product respectively.

I.2609

29 of 1964

EXPORT OF NIGERIAN PRODUCE ACT 1958  
(1958 No. 36)

Export of Nigerian Produce (Prescribed Grades and  
Standards) (Amendment) Regulations 1964

Commencement : 26th November, 1964

I exercise the powers conferred by Section 3 (a) of the Export of Nigerian  
Produce Act 1958 and of all other powers enabling me in that behalf, I hereby  
make the following Regulations :—

These regulations may be cited as the Export of Nigerian Produce  
(Prescribed Grades and Standards) (Amendment) Regulations 1964, and  
shall apply throughout the Federation.

1. The Standards prescribed in Regulation 2 of the Export of Nigerian  
Produce (Prescribed Grades and Standards) Regulations 1959 as amended  
by the Export of Nigerian Produce (Prescribed Grades and Standards)  
(Amendment) Regulations 1961 for grades of seed cotton, are further amended  
by the addition of the following new grade immediately after the prescription  
for Grade N.A. 2. :—

“GRADE N.A. 3

American seed cotton grown in Nigeria from approved seed which as  
regards freedom from immature seed cotton, damaged or stained seed  
cotton, insects, leaf trash, stalk and mineral matter does not qualify for  
Grade N.A. 1 or Grade N.A. 2, but still conforms to the current standard  
sample for Grade N.A. 3, and is entirely free from foreign fibre and  
added moisture”.

MADE at Lagos this 24th day of November, 1964.

Z. B. DIPCHARIMA,  
*Federal Minister of Commerce and Industry*

EXPLANATORY NOTE

The Northern Nigerian Marketing Board has by a resolution taken on 14th-15th  
November 1964 decided to re-introduce three grades of Seed Cotton. The  
decision has been accepted by the Nigerian Produce Marketing Company  
and the Eastern and Western Regional Marketing Boards. These  
resolutions add the third grade to the existing ones.

REGISTRATION OF TITLES ACT (CAP. 181)  
Registration of Titles (Application) Order, 1964  
Commencement : 9th October, 1964

In exercise of the powers conferred by subsection 1 of section 2 of the Registration of Titles Act and of all other powers enabling me in that behalf, I hereby make the following Order—

1. This Order may be cited as the Registration of Titles (Application) Order, 1964 and shall apply to the Federal Territory only.
2. The Registration of Titles Act shall apply to the area specified in the Schedule hereto.

Citation and application.  
Application of Cap. 181 to area specified in Schedule.

SCHEDULE

All that parcel of land at Surulere, Yaba West, Ebute Metta West and Abule-Nla on the Mainland of the Federal Territory the boundaries of which are described below :

Starting at a concrete pillar marked LD6544 the co-ordinates of which are 5,885.15 feet south and 7,895.21 feet west of a concrete pillar marked LCS165P, the origin of Lagos Cadastral Surveys the boundaries run in straight lines, the bearings and lengths of which are as follows :—

From	Bearings	Lengths	To
LD6544	111° 22'	483.6 feet	LD6543
LD6543	111° 22'	660.0 feet	LD6542
LD6542	58° 48'	185.5 feet	C.P.
C.P.	75° 55'	44.9 feet	EA2268
EA2268	30° 34'	64.3 feet	EA2267
EA2267	36° 08'	264.7 feet	EA2266
EA2266	49° 01'	137.6 feet	EA2265
EA2265	28° 34'	82.2 feet	EA2264
EA2264	49° 51'	233.5 feet	EA2263
EA2263	341° 43'	209.7 feet	EA2262
EA2262	357° 51'	109.7 feet	EA2261
EA2261	29° 10'	179.8 feet	EA2260
EA2260	1° 24'	51.5 feet	KE364
KE364	75° 44'	4,092.2 feet	LCS1487S
LCS1487S	68° 47'	3,055.4 feet	LCS1477S

Thence southwards along Clifford Street to Lagos Street ; thence westwards (into the Railway Compound) on a bearing of 245° 00' for a distance of 1,074 feet ; thence on a bearing of 156° 15' for a distance of 346 feet ; thence on a bearing of 244° 30' for a distance of 706 feet to Thomas Street ; thence along Thomas Street on a bearing of 156° 00' for a distance of 348 feet to PBL 2311 on its junction with Ibadan Street West ; thence along Ibadan Street West on a bearing of 244° 00' for a distance of 350 feet ; thence along Babani Street on a bearing of 155° 00' for a distance of 338 feet to a concrete pillar marked PBL 3860 ; thence on a bearing of 164° 12' at a distance of 17.0 feet to PBL 3859 on the junction of Apapa Road with

Babani Street; thence westwards along Apapa Road to its junction with Western Avenue; thence westwards along Apapa Road to its junction with Abebe (Iganmu) Road level crossing. Thence along Abebe (Iganmu) Road to a concrete pillar marked LCS 552P

From	Bearings	Lengths	To
552P	269° 40'	232.2 feet	553P
553P	296° 44'	598.0 feet	544P
554P	276° 20'	252.5 feet	555P
555P	245° 18'	266.4 feet	556P
556P	263° 21'	179.9 feet	557P
557P	248° 43'	168.5 feet	558P
558P	282° 57'	188.3 feet	559P
559P	293° 05'	275.2 feet	560P
560P	268° 21'	260.2 feet	561P

Thence southwards on a bearing of 180° 00' and an approximate distance of 671.5 feet to the edge of the swamp. Thence along the edge of the swamp in a zig-zag direction to a point P61 on the Federal Territory boundary.

From	Bearings	Lengths	To
P61	0° 00'	533.7 feet	PBC3646
PBC3646	0° 00'	1,058.1 feet	PBC3645
PBC3645	0° 00'	444.1 feet	PBC3644
PBC3644	0° 00'	1,229.4 feet	PBC3643
PBC3643	0° 00'	899.7 feet	LCS465P
LCS465P	0° 00'	292.1 feet	LCS464P
LCS464P	0° 00'	340.0 feet	LCS463P
LCS463P	0° 00'	580.5 feet	LD6544 (the starting point).

MADE in Lagos this 4th day of November, 1964.

MUSA YAR'ADUA,  
Minister of Lagos Affairs

#### EXPLANATORY NOTE

This Order extends the application of the Registration of Titles Act to certain parts of the Lagos Mainland not already within the ambit of the Act.

L.N. 127 of 1964

## MERCHANT SHIPPING ACT

(1962, No. 30)

## The Merchant Shipping (Grain) Rules, 1964

Commencement : 12th November, 1964

In exercise of the powers conferred by subsection 3 of section 253 of the Merchant Shipping Act, 1962, and of all other powers enabling me in that behalf, I hereby make the following Rules.

1. These Rules may be cited as the Merchant Shipping (Grain) Rules, 1964, and shall apply to:—
    - (a) ships which are loaded with grain within any port in Nigeria and go to sea therefrom; and
    - (b) ships which, having been loaded with grain outside Nigeria, enter any port in Nigeria so laden.
- Citation and application.
2. The precautions set out in the Schedule to these Rules are to be treated for the purposes of section 253 of the Act as necessary or reasonable precautions to prevent grain from shifting.
 

Precautions.
  3. Where these Rules require that any particular fitting, appliance or apparatus, or type thereof, shall be fitted or carried in a ship or that any particular provision shall be made, the Government Inspector of Shipping may allow any other fitting, appliance or apparatus, or type thereof, to be fitted or carried, or any other provision to be made in that ship if he is satisfied that such other fitting, appliance or apparatus, or type thereof, or provision is at least as effective as that required by these Rules.
 

Fitting, appliance or apparatus.

## SCHEDULE

(Rule 2)

## DEFINITIONS

1. In this Schedule, unless the context otherwise requires, the following expressions have the meanings hereby respectively assigned to them, that is to say:—

“Bin” means a completely enclosed section of cargo space in the between decks or superstructure of the ship;

“Grain” includes wheat, maize, oats, rye, barley, rice, pulses and seeds;

“Heavy grain” means all grain other than oats, light barley, and cotton seed;

“Light barley” means barley which weighs 51.575 lb. or less per bushel of 1.2837 cu. ft.

## SHIFTING BOARDS

2. Shifting boards shall be of a minimum thickness of 2 inches of good sound timber, and fitted grain-tight. They shall be supported by uprights.

3. The maximum unsupported span to be allowed for shifting boards of various thicknesses shall be as follows :—

<i>Thickness</i>	<i>Span</i>	<i>Housing at Bulkheads</i>
2 in. planks ..	Unsupported span not to exceed 8 feet ..	3 ins.
2½ in. planks ..	Unsupported span not to exceed 11 feet ..	3 ins.
3 in. planks ..	Unsupported span not to exceed 13 feet ..	3 ins.

4. Shifting boards shall be securely housed at each bulkhead by means either of permanent angle bars, or of wood cants not less than 6 ins. in width and 3 ins. in thickness and suitably shored.

5. Where 2½ in. or 3 in. shifting boards are used, the boards may be butt-jointed in way of the uprights, and at least 4 ins. of plank shall be supported. Where 2 in. shifting boards are used the joints shall overlap by at least 9 ins. in way of the uprights.

6. Where no permanent arrangements are made for grain-tight filling between the beams, wood filling pieces of the same thickness as the shifting boards shall be fitted grain-tight between the beams, and shall be secured in place by cleats or scabs at both ends and fitted both sides. The cleats or scabs shall be at least 2 in. x 4 in. in size and shall extend the full depth of the filling piece and as much again below, and be securely spiked or bolted to the shifting boards and filling pieces.

#### UPRIGHTS

7. Wood uprights shall not be less than 10 in. in width and 2 in. in thickness.

8. Uprights shall be cleated to the tanktop or ceiling where fitted, and when the upright is not securely housed at the top the uppermost supporting shores or stays shall not be more than 18 in. down from the deck or top of the upright.

9. If a tier of closely spaced pillars which serves as a principal support to the deck over in a hold or compartment is utilised for supporting the shifting boards at the middle line and if the pillars are not reeled or staggered, additional support shall be provided by means of hook-bolts and vertical tieplates or uprights secured to the pillars. Such tieplates shall consist of plates not less than 3 in. in width and ½ in. in thickness and shall be through-bolted at intervals of not more than 3 ft.

10. The horizontal distances between the centres of uprights shall be as specified in paragraph 3 of this Schedule. Wood uprights used in association with wire stays shall not be less than 11 in. in width and 3 in. in thickness. The construction and dimensions of angle bar uprights used in association with wire stays shall conform to the specification and method set forth in sub-paragraph (a) of this paragraph or to one of the following specifications and to the method set forth in sub-paragraph (b) thereof :—

(a) Each upright shall consist of four angle bars 4 in. x 4 in. x .40 in. and steel plate 11½ in. x .50 in. riveted to form one complete structure allowing 4 in. housings on both forward and after sides. Brackets riveted to head and heel shall be fitted, each to take five ⅜ in. bolts with corresponding lugs or angles on tanktop, tunnel top and hatch webs.

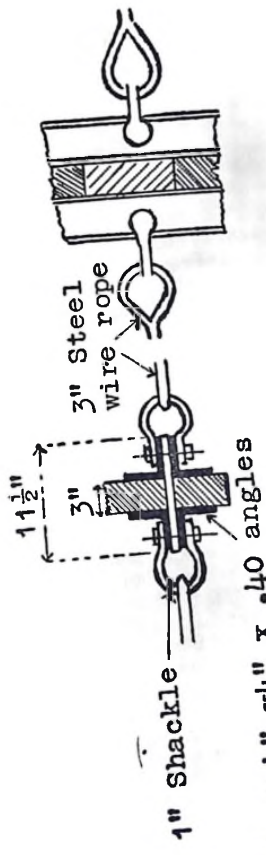

ELEVATION

PLAN

(b) Horizontal Dist. between centres of uprights

- 8 ft. (2" boards)
- 8 ft. (2" boards)
- 8 ft. (2" boards)
- 11 ft. (2 1/2" boards)
- 11 ft. (2 1/2" boards)
- 11 ft. (2 1/2" boards)
- 13 ft. (3" boards)
- 13 ft. (3" boards)
- 13 ft. (3" boards)

Sizes of angle bars

- 3" x 3" x .38 in.
- 3 1/2" x 3 1/2" x .38 in.
- 4 1/2" x 3 1/2" x .44 in.
- 3" x 3" x .38 in.
- 4" x 3 1/2" x .40 in.
- 6" x 3 1/2" x .40 in.
- 3" x 3 1/2" x .38 in.
- 4" x 3 1/2" x .42 in.
- 6" x 3 1/2" x .40 in.

Vertical Span supported by each stay

- 8 feet
- 11 feet
- 14 feet
- 8 feet
- 11 feet
- 14 feet
- 8 feet
- 11 feet
- 14 feet

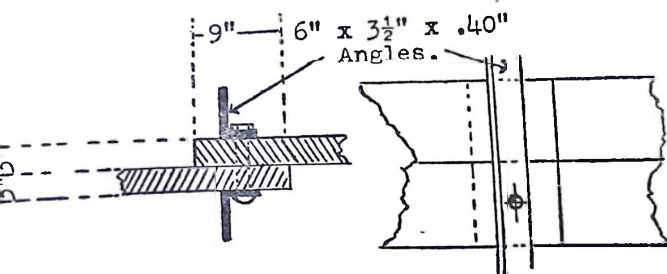

### OVERLAPS OF HOLD SHIFTING BOARDS

Vertical angle bars shall be connected at head and heel to the tanktop, tunnel top, deck beams, and hatch webs by angle lugs having two  $\frac{7}{8}$  in. bolts in each angle bar upright and fastenings of equal strength to tanktop, tunnel top, deck beams, and hatch webs. The vertical angle bars shall be bolted together through the shifting boards by  $\frac{7}{8}$  in. bolts approximately 4 ft. apart.

### SHORES AND STAYS

11. Wood uprights shall be supported by steel wire rope stays set up at the ship's side, or by wood shores securely heeled against the permanent structure of the ship. All wood shores shall be of good sound timber in a single piece.

### SHORES

12. The vertical spacing of wood shores shall be as follows :—

Except as provided in paragraph 8 of this Schedule the uppermost shore shall not be more than 7 ft. below the top of the upright and succeeding shores shall be spaced not more than 7 ft. apart measured vertically from the uppermost shore downwards, except that a distance of eight feet shall be permitted between the lowest shore and the heel support. Shores may be heeled on the tanktop or ceilings if the heels are secured by cleats or cants and efficiently braced against the permanent structure. Shores shall not be heeled directly against the ship's side plating.

13. Subject to the provisions of paragraphs 14 and 15 of this Schedule the sizes of wood shores shall be as follows :—

Length of Shores in feet	Minimum Sizes	
	Rectangular Section	Circular Section
Not exceeding 16 .. ..	6" x 4"	5½" diam.
Over 16 but not over 20 .. ..	6" x 6"	7" "
Over 20 but not over 24 .. ..	8" x 6"	7½" "
Over 24 but not over 28 .. ..	8" x 6"*	8" "
Over 28 feet .. ..	8" x 6"*	8½" "

\* Securely bridged at approximately mid-length.

Spliced shores shall not be used.

14. Subject to the provisions of paragraph 15 of this Schedule, if the spacings of the uprights or shores are less than those respectively referred to in paragraphs 3 and 12 of this Schedule the sizes of the shores may be reduced in proportion.

15. Where their angle from the horizontal does not exceed  $10^\circ$  the shores fitted shall be of the sizes specified in paragraph 13 of this Schedule. Where, by reason of the construction of the ship, their angle from the horizontal exceeds  $10^\circ$  then the next larger size of shore to that required by the horizontal shall be fitted. In no case shall the angle between any shore and the horizontal exceed  $45^\circ$ .

#### STAYS

16. One stay on each side of each upright shall be fitted in holds 20 ft. and under in depth and shall be placed at a distance below the deck of approximately one-third from under deck. In holds over 20 ft. in depth two stays on each side of each upright shall be fitted the upper stays being placed at a distance below the deck of approximately one-quarter of the depth of the hold and the lower stays at half the depth of the hold. For the purposes of this paragraph depths shall be measured to top of floors, inner bottom or tunnel top, as the case may be.

17. When stays are used the following provisions shall apply:—

(a) The stays shall be of 3 in. circumference flexible steel wire rope and shall be fitted horizontally.

(b) The rigging screws shall be  $1\frac{1}{4}$  in. in diameter and shall be fitted in accessible positions.

(c) The shackles shall be 1 in.

(d) The eye bolts through the wood or angle bar uprights shall be  $1\frac{1}{4}$  in.

(e)  $\frac{3}{8}$  in. screw bolts and nuts shall be provided as may be necessary for securing the wood uprights or steel angle bars.

(f) Either eye plates of 1 in. thickness shall be securely riveted to the side stringers or frames or 1 in. shackles passed through the frame.

18. If any shifting boards do not extend to the full depth of the hold the shifting boards and their uprights shall be supported or stayed so as to be as efficient as shifting boards which extend to the full depth of the hold.

#### CONSTRUCTION OF FEEDERS BINS AND BULKHEADS

19. Feeders, bins and bulkheads shall be of sufficient strength to withstand the pressure due to the head of grain contained therein and shall be grain-tight.

20. Ships having one or more decks with any continuous hold, whether forward or aft, with two hatches to that hold shall have a well-constructed bulkhead extending from side to side of the ship between the two hatches to divide the hold.

21. Wood feeders, wing feeders and bin bulkheads shall be constructed either:

(a) of planks which have been worked vertically and which are not less than  $2\frac{1}{2}$  in. thickness; when the vertical unsupported span of the planks exceeds 8 ft. the thickness thereof shall be increased proportionately or proportional additional stiffening shall be fitted; or

(b) of framing lined with grain-tight boards 2 in. in thickness or two 1 in. layers of shiplap, laid horizontally with broken joints; the framing shall where possible be placed inside the hatch coamings and shall be not less than 4 in. x 6 in. laid on edge spaced not more than 2 ft. apart centre to centre.

The planks at the corners shall be well secured to substantial vertical cants.

22. If the depth of the hatch end beams or coamings exceeds 15 in. below the surface of the deck, feeding holes shall be provided to allow the grain to flow through the coamings into the hold or 'tween decks. When the depth of the coamings below the surface of the deck exceeds 15 in. and does not exceed 18 in. feeding holes 2 in. in diameter shall be provided. When the depth exceeds 18 in. feeding holes of  $3\frac{1}{2}$  in. diameter shall be provided. Feeding holes shall be spaced approximately 2 ft. apart.

23. Engine-room and stokehold bulkheads and donkey boiler recesses, where subjected to heat, shall be sheathed with wood and made grain-tight. An air space of at least 6 in. shall be left between the bulkhead and the sheathing and a box trunk ventilator 6 in. x 8 in. in size shall be supported on vertical runners spaced not less than 2 ft. apart centre to centre and shall consist of 2 in. planks or two thicknesses of 1 in. boards laid to break joint.

## STOWAGE

### *Stowage of full holds and compartments*

24. Subject to the provisions of Regulation 26, if any hold or compartment is entirely filled with bulk grain it shall be divided either by a longitudinal bulkhead, or shifting boards in line with, or not more than 5 per cent of the moulded breadth of the ship from, the centre line or by longitudinal bulkheads or shifting boards off the centre line of the ship provided that the distance between them shall not exceed 60 per cent of the moulded breadth of the ship and that in the latter case trimming hatches of suitable size shall be provided in the wings at longitudinal intervals of not more than 25 feet with end trimming hatches placed not more than 12 feet from transverse bulkheads. In every case the longitudinal bulkheads or shifting boards shall be properly constructed and fitted grain-tight with proper fillings between the beams. In holds, such longitudinal bulkheads or shifting boards shall extend downwards from the underside of the deck to a distance of at least one-third of the depth of the hold or 8 feet whichever is the greater. In compartments in 'tween decks and superstructures they shall extend from deck to deck. In all cases the longitudinal bulkheads or shifting boards shall extend to the top of the feeders of the hold or compartment in which they are situated.

Provided that in the case of ships loaded with bulk grain other than linseed in which a metacentric height (after correction for the free surface effects of liquids in tanks) is maintained throughout the voyage of not less than 12 inches in the case of one or two deck ships and not less than 14 inches in the case of other ships, longitudinal bulkheads or shifting boards need not be fitted:—

(a) below and within 7 feet of a feeder, but only in way of a hatchway, if that feeder contains, or all the feeders collectively feeding a compartment contain, not less than 5 per cent of the quantity of grain carried in the compartment which is fed;

(b) in feeders which meet the requirements of paragraph (a) of this Regulation and which have such dimensions that the free grain surface will remain within the feeders throughout the voyage after allowing for a sillage of grain amounting to 2 per cent of the volume of the compartment horizontal; in this case the possible effects of the above mentioned movement of the free grain surfaces within the feeders shall be taken into account in calculating the metacentric height given above;

(c) in way of the hatchway where the bulk grain beneath the hatchway is trimmed in the form of a saucer hard up to the deckhead beyond the hatchway and is topped off with bagged grain or other suitable bagged cargo extending to a height in the centre of the saucer of not less than 6 feet above the top of the bulk grain (measured below the deck line); the bagged grain or other suitable bagged cargo shall fill the hatchway and the saucer below and shall be stowed tightly against the deckhead and longitudinal bulkheads, the hatchway beams and, the hatchway side and end coamings.

*Stowage of partly filled holds and compartments*

25. Subject to the provisions of Regulation 26, if any hold or compartment is partly filled with bulk grain:—

(a) it shall be divided by a longitudinal bulkhead or shifting boards, in line with, or not more than 5 per cent of the moulded breadth of the ship from, the centre line or by longitudinal bulkheads or shifting boards off the centre line of the ship provided that the distance between them shall not exceed 60 per cent of the moulded breadth of the ship. In every case the longitudinal bulkheads or shifting boards shall be properly constructed and shall extend from the bottom of the hold or deck, as the case may be, to a height of not less than 2 feet above the surface of the bulk grain.

Provided that, except in the case of holds partly filled with linseed in bulk, longitudinal bulkheads or shifting boards need not be fitted in way of the hatchway in the case of ships in which a metacentric height (after correction for the free surface effects of liquids in tanks) is maintained throughout the voyage of not less than 12 inches in the case of one or two deck ships and not less than 14 inches in the case of other ships;

(b) the bulk grain shall be levelled and topped off with bagged grain or other suitable cargo tightly stowed and extending to a height of not less than 4 feet above the top of the bulk grain within spaces divided by such a longitudinal bulkhead or shifting boards, and not less than 5 feet within spaces not so divided. The bagged or other suitable cargo shall be supported on suitable platforms laid over the whole surface of the bulk grain; such platforms shall consist of bearers spaced not more than 4 feet apart and 1 inch boards laid thereon spaced more than 4 inches apart or of strong separation cloths with adequate overlapping.

*Exceptions to the requirements for longitudinal bulkheads*

26. The fitting of longitudinal bulkheads or shifting boards in accordance with the provisions of Regulations 24 and 25 shall not be required:—

(a) in a lower hold (which term also includes the lower part of the hold of a single-deck ship) if the bulk grain therein does not exceed one-third the capacity of the hold, or where such lower hold is divided by a shaft tunnel, one-half the capacity of that lower hold;

(b) in any space in a 'tween deck or superstructure provided that the wings are tightly stowed with bagged grain or other suitable cargo to a breadth on each side of not less than 20 per cent of the breadth of the ship in way thereof ; and

(c) in those parts of spaces where the maximum breadth of the deckhead within the said spaces does not exceed one-half of the moulded breadth of the ship.

#### *Feeders*

27. (a) (i) Any hold or compartment which is entirely filled with bulk grain shall be fed by suitably placed and properly constructed feeders, except as otherwise provided in paragraph (c) of Regulation 24 and Regulations 28 and 32 so as to secure a free flow of grain from the feeder to all parts of that hold or compartment.

(ii) Each feeder shall contain not less than 2 per cent of the quantity of grain carried in that part of the hold or compartment that it feeds except as otherwise provided for in paragraph (a) of Regulation 24.

(b) When bulk grain is carried in deep tanks primarily constructed for the carriage of liquids to which paragraph (c) of Regulation 26 applies or that are divided by one or more permanent steel longitudinal divisions fitted grain-tight, feeders to the tanks may be omitted if the tanks and tank hatchways are completely filled and the hatch covers secured.

#### *Common Loading*

28. For the purpose of Regulations 24 and 27 of this Chapter lower holds and 'tween deck spaces over them may be loaded as one compartment under the following conditions :—

(a) longitudinal bulkheads or shifting boards shall be fitted deck to deck in the 'tween deck of a ship having two decks ; in all other cases the longitudinal bulkheads or shifting boards shall be fitted for the upper third of the total depth of the common spaces ;

(b) in order to secure an adequate flow of grain all spaces shall comply with the requirements of Regulation 29 of this Chapter and openings shall be provided in the wings of the deck immediately below the uppermost deck forward and aft of the ends of the hatchways as necessary to provide in combination with the hatchways a maximum feeding distance of 8 feet measured in a fore and aft line.

#### *Trimming and bagging of end spaces*

29. When the distance, measured in a fore and aft line, from any part of a hold or compartment to the nearest feeder exceeds 25 feet the bulk grain in the end spaces beyond 25 feet from the nearest feeder shall be levelled off at a depth of at least 6 feet below the deck, and the end spaces filled with bagged grain built up on a suitable platform as required in paragraph (b) of Regulation 25.

*Bulk grain in 'tween decks and superstructures*

30. Bulk grain shall not be carried above deck, in the 'tween deck of a two deck ship, or in the uppermost 'tween deck of a ship having more than two decks except under the following conditions :—

(a) the bulk grain or other cargo shall be stowed so as to ensure maximum stability : in all cases either a metacentric height (after correction for the free surface effects of liquids in tanks) shall be maintained throughout the voyage of not less than 12 inches in the case of one or two deck ships and 14 inches in the case of other ships or, alternatively, the aggregate quantity of bulk grain or other cargo carried above deck, in the 'tween deck spaces of a two deck ship or in the uppermost 'tween deck spaces of a ship having more than two decks shall not exceed 28 per cent by weight of the total cargo below the 'tween deck where the master is satisfied that the ship will have adequate stability throughout the voyage ; the limitation of 28 per cent specified above shall not apply when the grain carried above deck or in the uppermost 'tween deck spaces is oats, barley or cotton seed ;

(b) the deck area of any portion of the spaces referred to in this Regulation which contains bulk grain and which is only partly filled shall not exceed 1,000 square feet ; and

(c) all spaces referred to in this Regulation in which bulk grain is stowed shall be subdivided by transverse bulkheads at intervals of not more than 100 feet ; when this distance is exceeded the excess space shall be entirely filled with bagged grain or other suitable cargo.

*Limitation on number of partly filled holds and compartments*

31. Except in the case of ships in which a metacentric height (after correction for the free surface effects of liquids in tanks) is maintained throughout the voyage of not less than 12 inches in the case of one or two deck ships, and not less than 14 inches in the case of other ships, not more than two holds or compartments shall be partly filled with bulk grain, except that other holds or compartments may be partly filled with bulk grain if they are filled up to the deckhead with bagged or other suitable cargo. For the purpose of this Regulation :—

(a) superimposed 'tween decks shall be regarded as separate compartments and separate from any lower hold below them ;

(b) feeders and the partly filled spaces referred to in paragraph (b) of Regulation 30 shall not be regarded as compartments ; and

(c) holds or compartments provided with one or more grain-tight longitudinal divisions shall be regarded as one hold or compartment.

*Stowage of specially suitable ships*

32. (a) Notwithstanding anything contained in Regulations 24 to 31, bulk grain may be carried without regard to the requirements specified therein in ships which are constructed with two or more vertical or sloping grain-tight longitudinal divisions suitably disposed to limit the effect of any transverse shift of grain under the following conditions :—

(i) as many holds and compartments as possible shall be full and trimmed full ;

(ii) for any specified arrangement of stowage the ship will not list to an angle greater than 5 degrees at any stage of the voyage where :—

(1) in holds or compartments which have been trimmed full the grain surface settles 2 per cent by volume from the original surface and shifts to an angle of 12 degrees with that surface under all boundaries of these holds and compartments which have an inclination of less than 30 degrees to the horizontal ; and

(2) in partly filled holds or compartments free grain surfaces settle and shift as in sub-paragraph (ii) (1) of this paragraph or to such larger angle as may be deemed necessary by the Government Inspector of Shipping, and grain surfaces if overstowed in accordance with Regulation 25 shift to an angle of 8 degrees with the original levelled surfaces. For the purposes of sub-paragraph (ii) of this paragraph shifting boards if fitted will be considered to limit the transverse shift of the surface of the grain ;

(iii) the master is provided with a grain loading plan covering the stowage arrangements to be adopted and a stability booklet, both approved by the Government Inspector of Shipping, showing the stability conditions upon which the calculations given in sub-paragraph (ii) of this paragraph are based.

(b) The Government Inspector of Shipping shall prescribe the precautions to be taken against shifting in all other conditions of loading of ships designed in accordance with paragraph (a) of this Regulation which meet the requirements of sub-paragraphs (ii) and (iii) of that paragraph.

(c) The Government Inspector of Shipping, shall prescribe the precautions to be taken against shifting in a ship of any other design which meets the requirements of sub-paragraphs (ii) and (iii) of paragraph (a) of this Regulation.

#### *Water Ballast Tanks*

33. Double bottom tanks which are used to meet a stability requirement in ships loading bulk grain shall have adequate watertight longitudinal subdivision except where the width of the tank measured at half length does not exceed 60 per cent of the ship's moulded breadth.

#### *Bagged Grain*

34. Bagged grain shall be carried in sound bags which shall be well filled and securely closed.

#### *Grain Loading Plans*

35. Ships shall have a grain loading plan drawn up by the Government Inspector of Shipping in accordance with these regulations, or by the Government of any other nation who has acceded to the Safety of Life at Sea Convention, 1960.

*Exemptions for certain Voyages*

36. The Government Inspector of Shipping, may, if he considers that the sheltered nature and conditions of the voyages are such as to render the application of any of the requirements of Regulations 24 to 35 unreasonable or unnecessary, exempt from those particular requirements individual ships or classes of ships for voyages within Nigerian waters.

MADE at Lagos this 12th day of November, 1964.

R. A. NJOKU,  
*Federal Minister of Transport*

EXPLANATORY NOTE

These rules make provisions for precautions which are considered to be necessary or reasonable to prevent grain shifting when it is being carried in ships in any part of Nigeria.



# THE MERCHANT SHIPPING (LOAD LINE) RULES, 1964

## ARRANGEMENT OF RULES

### PART I.—GENERAL

1. Citation.
2. Application.
3. Interpretation.
4. Revocation.

### PART II.—SURVEYS

5. Application for Load Line Certificate.
6. Load Line Survey.
7. Annual Survey.

### PART III.—LOAD LINE MARKS

8. Marking.
9. Method of marking.
10. Marks on steamers.
11. Marks on sailing ships.
12. Timber load lines.
13. Tankers and special type steamers.
14. Marks of Assigning Authority.

### PART IV.—CERTIFICATES

15. Form and issue of load line certificate.
16. Delivery of certificates.

### PART V.—CONDITIONS OF ASSIGNMENT

#### Openings in Freeboard and Superstructure Decks

17. Hatchways not protected.
18. Hatchway coamings.
19. Hatchway covers.
20. Hatchway beams and fore-and-afters.
21. Carriers or sockets.
22. Cleats.
23. Battens, wedges and tarpaulins.
24. Security of hatchway covers.
25. Closing arrangements : coamings.
26. Machinery space openings : freeboard and raised quarter deck.
27. Machinery space openings superstructure decks other than raised quarter decks.
28. Machinery space openings with closing appliances less than Class 1.
29. Flush bunker scuttles.
30. Companionways.
31. Ventilators.
32. Air pipes.

#### Openings in the Sides of Ships

33. Gangway, cargo, coaling ports etc.
34. Scuppers and sanitary discharge pipes.
35. Side scuttles.

36. Guard rails.
37. Freeing ports.
38. Protection of crew.
39. Special provision for exceptional ships.

## PART VI.—COMPUTATION OF FREEBOARDS FOR STEAMERS

40. Freeboards for steamers.
41. Length.
42. Breadth.
43. Moulded depth.
44. Depth for freeboard.
45. Coefficient of fineness.

## Strength

46. Strength to be adequate.

## Superstructures

47. Height of superstructure.
48. Standard height.
49. Length of superstructure.
50. Enclosed superstructure.
51. Superstructure bulkheads.

Appliances for Closing Access Openings in Bulkheads at ends of  
Detached Superstructures

52. Class 1 closing appliances.
53. Class 2 closing appliances.
54. Temporary closing appliances.

## Effective Length of Detached Superstructures

55. Application of Rules 56 to 61.
56. General.
57. Poop.
58. Raised quarter deck.
59. Bridge.
60. Forecastle.
61. Trunks.
62. Openings without permanent means of closing.
63. Deductions for superstructures.

## Sheer

64. General.
65. Standard sheer profile.
66. Measurement of variations.
67. Correction for variations.
68. Addition for deficiency.
69. Deduction for excess.

## Round of Beam

70. Standard.
71. Correction.

## Minimum Freeboards

- 72. Summer.
- 73. Tropical.
- 74. Winter.
- 75. Winter North Atlantic.
- 76. Fresh water.
- 77. Freeboard table.

## PART VII.—COMPUTATION OF FREEBOARDS FOR SAILING SHIPS

- 78. Computation of freeboard.
- 79. Depth for freeboard.
- 80. Coefficient of fineness
- 81. Superstructures in wooden ships.
- 82. Deductions for superstructures.
- 83. Minimum freeboards.
- 84. Freeboard table for sailing ships.
- 85. Freeboard for wooden sailing ships.

PART VIII.—FREEBOARDS FOR STEAMERS CARRYING TIMBER  
DECK CARGOES

- 86. Assignment.

## Supplementary Conditions of Assignment

- 87. Construction.
- 88. Superstructures.
- 89. Machinery casings.
- 90. Double bottom tanks.
- 91. Bulwarks.
- 92. Steering arrangements.
- 93. Lashings.

## Computation of Freeboard

- 94. Computation.
- 95. Special cases.

## PART IX.—FREEBOARDS FOR TANKERS

- 96. Assignment.

## Supplementary Conditions of Assignment

- 97. Construction.
- 98. Forecastle.
- 99. Machinery spaces.
- 100. Gangways.
- 101. Protection of crew, etc.
- 102. Hatchways.
- 103. Ventilators.
- 104. Freeing arrangements.

## Computation of Freeboard

- 105. Computation.
- 106. Deduction for detached superstructures.
- 107. Deduction for excess sheer.
- 108. Winter North Atlantic.
- 109. Freeboard table for tankers.
- 110. Special provision.

## PART X.—FREEBOARDS FOR SHIPS OF SPECIAL TYPE

- 111. Freeboards in special cases.

## PART XI.—LOAD LINES

- 112. Steamers.
- 113. Sailing ships.
- 114. Steamers carrying deck timber cargoes.
- 115. Boundary ports.

PART XII.—LOAD LINES FOR STEAMERS PLYING ON INLAND  
WATERS ONLY

- 116. Load Line.
- 117. Depth.
- 118. Position of load line.
- 119. Freeboard.
- 120. Conditions of Assignment.
- 121. Delegation of powers.

FIRST SCHEDULE — Fees.

SECOND SCHEDULE — Form LL.1—International Load Line Certificate.  
 — Form LL.2—International Load Line Certificate.  
 — Form LL.3—International Load Line Certificate.  
 — Form LL.4—Nigerian Load Line Certificate.  
 — Form LL.5—Nigerian Load Line Certificate.

THIRD SCHEDULE — Zones and Seasonal Areas.

APPENDIX I — Table of scantlings.

L.N. 108 of 1964

MERCHANT SHIPPING ACT, 1962  
(1962, No. 30)

The Merchant Shipping (Load Line) Rules, 1964

Commencement : 17th September, 1964

In exercise of the powers conferred by section 201 of the Merchant Shipping Act, 1962, the Federal Minister of Transport hereby makes the following Rules :—

PART I.—GENERAL

- |   |                        |
|---|------------------------|
| <p>1. These Rules may be cited as the Merchant Shipping (Load Line) Rules, 1964.</p>  | <p>Citation.</p>       |
| <p>2. These Rules shall apply to all Nigerian ships subject to the provisions of sections 202 and 229 of the Act and also to all other ships subject to the provisions of Chapter 36 of the Act.</p>  | <p>Application.</p>    |
| <p>3. In these Rules unless the context otherwise requires—<br/> “Amidships” means the middle of the length of the summer load water line as defined in Rule 41 ;<br/> “Assigning Authority”, means the Minister, Lloyd’s Register of Shipping, the British Committee of the Bureau Veritas, or the British Technical Committee of the American Bureau of Shipping ;<br/> “Conditions of Assignment” means the conditions of assignment set out in Part V of these Rules ;<br/> “Freeboard Deck” means the uppermost complete deck having permanent means of closing all openings in weather portions of the deck in accordance with Rules 17 to 24, and in flush deck ships and ships having detached superstructures means the upper deck. In ships having discontinuous freeboard decks within superstructures which are not intact, or which are not fitted with Class 1 closing appliances as defined in Rule 52, the lowest line of the deck below the superstructure deck shall be deemed to be the freeboard deck ;<br/> “Flush Deck Ship” means a ship which has no superstructure on the freeboard deck ;<br/> “Load Line Ship” means any sea-going ship which is not a ship to which rules made or deemed to have been made pursuant to section 202 of the Act apply, or in respect of which a certificate issued under subsection 3 of that section is in force.<br/> “Special Steamer Freeboard” means a freeboard assigned under Part X of these Rules ;<br/> “Steamer” includes all ships having sufficient means for mechanical propulsion, and for the purposes of these Rules a lighter, barge or other ship without independent means of propulsion, when towed, is deemed to be a steamer ;<br/> “Superstructure” means a decked structure on the freeboard deck extending from side to side of the ship, and includes a “raised quarter deck” and “superstructure deck” means the deck forming the top of a superstructure ;</p> | <p>Interpretation.</p> |

"Surveyor" means a Surveyor appointed by the assigning authority.  
 "Tanker" includes all steamers specially constructed for the carriage of liquid cargoes in bulk ;

"Tanker Freeboard" means a freeboard assigned under Part IX of these Rules :

"Timber Cargo Regulations" means any regulations, for the time being in force under section 225 of the Act ;

"Timber Deck Cargo" means a cargo of timber carried on an uncovered part of a freeboard or superstructure deck, but does not include a cargo of wood pulp or similar substance ;

"Timber Freeboard" means a freeboard assigned under Part VIII of these Rules.

Revocation.

4. All references to Load Lines in the following enactments are hereby revoked—

- (a) The Survey of Vessels (Sea-going) Regulations, 1959, and
- (b) The Survey of Vessels (Inland Waters) Regulations, 1959.

## PART II.—SURVEYS

Application for load line certificate.

5.—(1) Every application for the issue or renewal of a load line certificate shall be made by or on behalf of the owner of the ship to an Assigning Authority.

(2) Every application for the issue or renewal of a load line certificate in respect of timber freeboards shall be accompanied by such plans as the Assigning Authority may require, showing the fittings and arrangements for stowing and securing timber deck cargoes in accordance with Part VIII of these Rules and any regulations which may be made under section 225 (1) of the Merchant Shipping Act, 1962.

(3) Every application for the issue or renewal of a load line certificate in respect of tanker freeboards shall be accompanied by such plans as the Assigning Authority may require, showing the fittings and arrangements provided or to be provided for the purpose of complying with Part IX of these Rules.

(4) On every such application, there shall be paid by the owner the prescribed fee as laid down in the Merchant Shipping (Fees) Regulations, 1963.

Load Line Survey.

6.—(1) The Assigning Authority shall upon receipt of the application and of the prescribed fee cause the ship to be surveyed by a qualified surveyor as hereinafter provided.

(2) The surveyor shall survey the ship with a view to satisfying himself—

(a) that the material and workmanship of all parts of the hull of the ship are in all respects satisfactory and efficient and that having regard to the period for which the load line certificate is to be issued or renewed the hull is in good condition internally and externally ;

(b) that if the keel of the ship was laid on or after 1st July, 1932, she complies with the Conditions of Assignment to the extent thereby required in her case ; or if the keel was laid before that date, she complies with the Conditions of Assignment in principle and also in detail so far as is reasonable and practicable having regard to the efficiency of the protection of openings, the guard rails, the freeing ports, and the means of access to the crew's quarters provided by the arrangements, fittings and appliances existing on the ship at the time of survey ;

(c) in the case of an application for the issue or renewal of a certificate in respect of timber freeboards, that the ship also complies with the provisions of Part VIII of these Rules to the extent thereby required in her case ;

(d) in the case of an application for the issue or renewal of a certificate in respect of tanker freeboards, that the ship also complies with the provisions of Part IX of these Rules to the extent thereby required in her case ; and

(e) in the case of an application for the issue or renewal of a certificate in respect of special steamer freeboards, that the ship also complies with the provisions of Part X of these Rules to the extent thereby required in her case.

(3) On the completion of the survey the surveyor shall forward to the Assigning Authority a report stating the result of the survey and containing such particulars of the ship as are required by the Assigning Authority to enable them to assign the appropriate freeboards to the ship.

(4) On receipt of the surveyor's report the Assigning Authority, if satisfied that the ship complies with the appropriate provisions of these Rules to the extent thereby required in her case, shall assign freeboards to the ship, in accordance with such of these Rules as are applicable to the ship, and shall furnish the owner with particulars as to the nature of the load lines and of the position in which the deck line and the load lines are to be marked on the ship.

7.—(1) Every application for the survey of a ship under subsection (7) of section 208 of the Act for the purpose of seeing whether her load line certificate should remain in force shall be made by or on behalf of the owner to the Assigning Authority by whom the certificate was issued.

(2) There shall be paid in respect of such survey the prescribed fee.

(3) The Assigning Authority shall, upon receipt of the application and of the prescribed fee, cause the ship to be surveyed by a qualified surveyor.

(4) The surveyor shall survey the ship with a view to satisfying himself—

(a) that the fittings and appliances for the protection of openings, the guard rails, the freeing ports and the means of access to the crew's quarters have been maintained on the ship in as effective a condition as they were in when the certificate was issued ; and

(b) that no material alterations have taken place in the hull or superstructures of the ship which affect the positions of the load lines.

(5) Upon completion of the survey to the satisfaction of the surveyor, he shall forward a report thereon to the Assigning Authority and endorse on the certificate a statement that the survey of the ship has been so completed.

### PART III.—LOAD LINE MARKS

8. On receiving from the assigning Authority the particulars as to the deck line and load lines as provided in Rule 6, the owner shall cause to be marked on each side of the ship, to the satisfaction of the surveyor, the appropriate marks in accordance with this Part of these Rules.

9. The disc, lines and letters described in Rule 10 shall be marked in such manner as in the surveyor's opinion will make them plainly visible. They shall be painted in white or yellow on a dark ground or in black on a light ground, and shall also be carefully cut in or centre-punched on a sides of iron and steel ships, and on wood ships shall be cut into the planking for at least one-eighth of an inch.

Annual  
Survey.

Marking.

Method of  
marking.

10. A steamer shall be marked on each side with a deck line and load lines as follows :—

(a) A deck line which shall be a horizontal line twelve inches in length and one inch in breadth marked amidships with its upper edge passing through the point where the continuation outwards of the upper surface of the freeboard deck intersects the outer surface of the shell. (See figure 1). Where the deck is partly sheathed amidships, the upper edge of the deck line shall pass through the point where the continuation outwards of the upper surface of the actual sheathing at amidships intersects the outer surface of the shell.

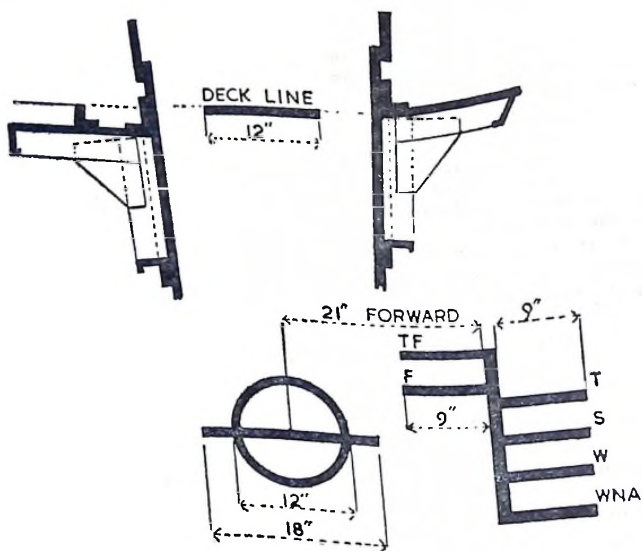

FIGURE 1.

(b) A load line disc twelve inches in diameter intersected by a horizontal line eighteen inches in length and one inch in breadth, the upper edge of which passes through the centre of the disc amidships below the deck line. The disc shall be marked

(c) Horizontal lines nine inches in length and one inch in breadth which extend from, and are at right angles to, a vertical line 21 inches forward depth to which the ship (see figure 1) and which indicate the maximum different seasons. These lines are as follows :—

The *Summer Load Line* indicated by the upper edge of the line which passes through the centre of the disc and also by the upper edge of a line marked S.

The Winter Load Line indicated by the upper edge of a line marked W.

The Winter North Atlantic Load Line indicated by the upper edge of a line marked WNA. This line shall not be marked on a steamer over 330 feet in length not being a tanker or a steamer of special type to which Rule 13 applies.

The Tropical Load Line indicated by the upper edge of a line marked T.

The Fresh Water Load Line in summer indicated by the upper edge of a line marked F.

The Tropical Fresh Water Load Line indicated by the upper edge of a line marked TF.

11. A sailing ship shall be marked on each side of the ship with a deck line and a Winter North Atlantic load line as provided in Rule 10 and with a Fresh Water Load Line indicated by the upper edge of a line marked F. (See figure 2).

Marks on sailing ships.

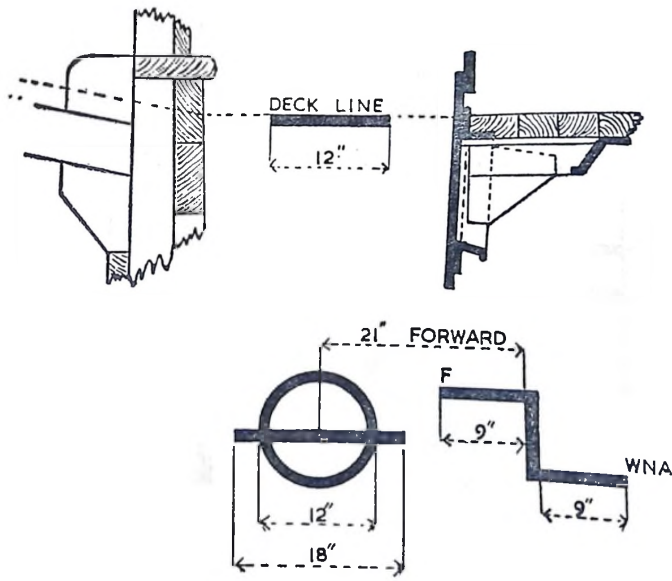

FIGURE 2

12. Every steamer to which timber load lines are assigned in accordance with Part VIII of these Rules shall be marked with the following lines in addition to the lines referred to in Rule 10:—

Horizontal lines nine inches in length and one inch in breadth, which extend from, and are at right angles to, a vertical line marked twenty-one

Timber load lines.

inches abaft the centre of the disc (see figure 3) and which indicate the maximum timber load lines in different circumstances and in different seasons. These lines are as follows :—

*The Summer Timber Load Line* indicated by the upper edge of a line marked LS.

*The Winter Timber Load Line* indicated by the upper edge of a line marked LW.

*The Winter North Atlantic Timber Load Line* indicated by the upper edge of a line marked LWNA.

*The Tropical Timber Load Line* indicated by the upper edge of a line marked LT.

*The Fresh Water Timber Load Line* in summer indicated by the upper edge of a line marked LF.

*The Fresh Water Timber Load Line* in the Tropical Zone indicated by the upper edge of a line marked LTF.

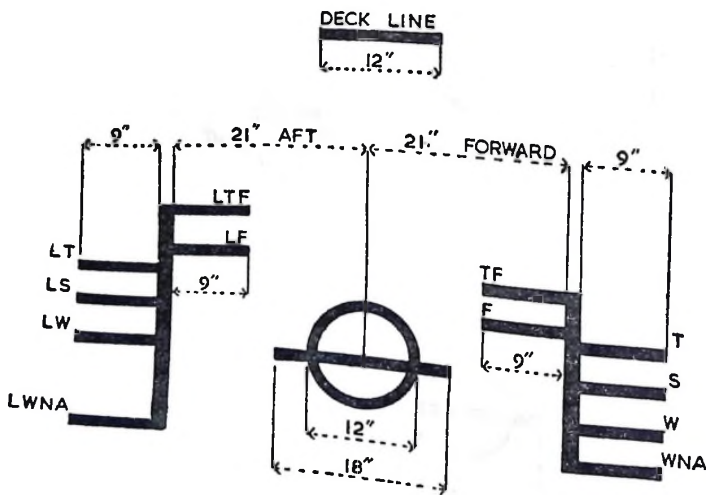

FIGURE 3.

Tankers  
and Special  
Type  
Steamers.

13. Every tanker to which a tanker freeboard is assigned in accordance with Part IX of these rules and every steamer of special type to which a freeboard is assigned in accordance with Part X of these Rules shall be marked with the lines referred to in Rule 10 provided that the Winter North Atlantic Load Line shall always be marked whatever the length of the steamer.

14. For the purpose of indicating the name of the Assigning Authority by whom the freeboards have been assigned, letters measuring about 4½ inches by 3 inches may be marked alongside the disc and above the line through the centre of the disc.

Marks of Assigning Authority.

PART IV.—CERTIFICATES

15. Every load line certificate in respect of freeboards assigned to a ship shall be issued by the Assigning Authority by whom those freeboards were assigned and shall be in such one of the forms set out in the Second Schedule to these Rules as is appropriate to the case, or in such other form substantially to the like effect as the Minister may from time to time direct.

Form and issue of load line certificates.

16.—(1) On the Assigning Authority being satisfied that the ship has been marked to the surveyor's satisfaction as required by these Rules and that the prescribed fee has been paid, the certificate shall be delivered to the applicant with a certified copy thereof.

Delivery of certificates.

(2) A further certified copy of each certificate issued by an Assigning Authority other than the Minister, shall be sent to the Minister.

PART V.—CONDITIONS OF ASSIGNMENT

Openings in Freeboard and Superstructure Decks

17. The construction and fitting of cargo and other hatchways in exposed positions on freeboard and superstructure decks shall be at least equivalent to the standards laid down in Rules 18 to 24.

Hatchways not protected.

18.—(1) The height of hatchway coamings on freeboard decks shall be at least 24 inches above the deck. The height of coamings on superstructure decks shall be at least 24 inches above the deck if situated within a quarter of the ship's length from the stem, and at least 18 inches if situated elsewhere.

Hatchway coamings.

(2) Coamings shall be of steel, shall be substantially constructed and, where required to be 24 inches high, shall be fitted with an efficient horizontal stiffener placed not lower than 10 inches below the upper edge, and with efficient brackets or stays from the stiffener to the deck, at intervals of not more than 10 feet.

19.—(1) Covers to exposed hatchways shall be efficient, and where they are made of wood, the finished thickness shall be at least 2¾ inches in association with a span of not more than 5 feet. The width of each bearing surface for wood hatchway covers shall be at least 2½ inches.

Hatchway covers.

(2) The ends of the wood covers shall be protected by galvanised steel bands efficiently secured, except that this requirement shall not apply to wood covers in use before 1st January, 1947, but when in the opinion of the Assigning Authority the renewal of a wood cover becomes necessary, effect shall be given to this requirement.

20. Where wood hatchway covers are fitted the hatchway beams and fore-and-afters shall be on the scantlings and spacing given in Table 1 in Appendix 1 to these Rules, where coamings 24 inches high are required, and as given in

Hatchway beams and fore-and-afters.

Table 2 of the said Appendix where coamings 18 inches high are required. Angle bar mountings on the upper edge shall extend continuously for the full length of each beam. Wood fore-and-afters shall be steel shod at all bearing surfaces.

Carriers or sockets.

21. Carriers or sockets for hatchway beams and fore-and-afters shall be of steel at least  $\frac{1}{2}$  inch thick, and shall have a width of bearing surface of at least 3 inches.

Cleats.

22.—(1) Strong cleats at least  $2\frac{1}{2}$  inches wide shall be fitted at intervals of not more than 2 feet from centre to centre; the end cleats shall be placed not more than 6 inches from each corner of the hatchway.

(2) Cleats shall be of a pattern approved by the Assigning Authority and shall be set to fit the taper of the wedges:

Provided that these requirements shall not apply to any ship the keel of which was laid before 1st January, 1947.

Battens, wedges, and tarpaulins.

23.—(1) Battens and wedges shall be efficient and in good condition.

(2) Wedges shall be made from tough wood cut to a taper of 1 in 6 and shall not be less than  $\frac{1}{2}$  inch thick at the toe;

Provided that these requirements shall not apply to any ship the keel of which was laid before 1st January, 1947.

(3) At least two tarpaulins in good condition, thoroughly waterproofed and of ample strength, shall be provided for each hatchway in an exposed position on freeboard and superstructure decks. The material of the tarpaulins shall be guaranteed free from jute, and the minimum weight of the material, before treatment, shall be 19 ozs. per square yard if to be tarred, for black oil dressing, or 16 ozs. per square yard if to be chemically dressed.

Security of hatchway covers.

24.—(1) Where the coamings are required to be 24 inches high—  
 (a) steel bars or other equipment shall be provided for efficiently and independently securing each section of hatchway covers after the tarpaulins are battened down;

(b) at all other hatchways in exposed positions on freeboard and superstructure decks, ring bolts or other fittings for lashings shall be provided;

(c) where the hatchway covers extend over intermediate supports steel bars or their equivalent shall be fitted at each end of each section of the covers;

Provided that in the case of any ship the keel of which was laid before 1st January, 1947, the foregoing requirements of this Rule shall not apply unless in the opinion of the Assigning Authority compliance therewith would be reasonable and practicable.

(2) Where, by virtue of the proviso to paragraph (1) of this Rule, the foregoing provisions of the said paragraph (1) do not apply in the case of any ship, the following provisions shall apply—

(a) at all hatchways in exposed positions on the freeboard and superstructure decks, ring bolts or other fittings for lashings shall be provided;

(b) where the breadth of the hatchway exceeds 60 per cent of the breadth of the deck in the way of the hatchway and the coamings are required to be 24 inches high, fittings for special lashings shall be provided for securing the hatchway covers after the tarpaulins are battened down.

25.—(1) Cargo, coaling and other hatchways in the freeboard deck within superstructures which are fitted with closing appliances less efficient than Class 1 but not less efficient than Class 2 shall have coamings at least 9 inches in height and closing arrangements as effective as those required for exposed cargo hatchways whose coamings are 18 inches high.

Closing arrangements, coamings.

(2) Where the closing appliances are less efficient than Class 2, the hatchways shall have coamings at least 18 inches in height, and shall have fittings and closing arrangements as effective as those required for exposed cargo hatchways.

26.—(1) Machinery space openings in exposed positions on freeboard and raised quarter decks shall be properly framed and efficiently enclosed by steel casings of ample strength. Doors in such casings shall be of steel, efficiently stiffened, permanently attached, and capable of being closed and secured from both sides. The sills of openings shall be at least 24 inches above the freeboard deck and at least 18 inches above the raised quarter deck.

Machinery space openings. Freeboard and raised quarter deck.

(2) Fiddley, funnel and ventilator coamings shall be as high above the deck as is reasonable and practicable. Fiddley openings shall have strong steel covers permanently attached in their proper positions.

27.—(1) Machinery space openings in exposed positions on superstructure decks other than raised quarter decks shall be properly framed and efficiently enclosed by strong steel casings. Doors in such casings shall be strongly constructed, permanently attached, and capable of being closed and secured from both sides. The sill of the openings shall be at least 15 inches above superstructure decks.

Machinery space openings. Superstructure decks other than raised quarter decks.

(2) Fiddley, funnel and ventilator coamings shall be as high above the deck as is reasonable and practicable. Fiddley openings shall have strong steel covers permanently attached in their proper positions.

28. Machinery space openings in the freeboard deck within superstructures which are fitted with closing appliances less efficient than Class 1 shall be properly framed and efficiently enclosed by steel casings. Doors in such casings shall be strongly constructed, permanently attached and capable of being securely closed. The sills of the openings shall be at least 9 inches above the deck where the superstructures are closed by Class 2 closing appliances, and at least 15 inches above the deck where the closing appliances are less efficient than Class 2.

Machinery space openings, with closing appliances less than Class 1.

29.—(1) Flush bunker scuttles may only be fitted in superstructure decks, except in the case of small ships in special trades where they may be fitted in other positions by permission of the Assigning Authority.

Flush bunker scuttles.

(2) Such scuttles shall be of iron or steel, of substantial construction, with screw or bayonet joints. Where a scuttle is not secured by hinges, a permanent chain attachment shall be provided.

30. Companionways in exposed positions on freeboard decks and on decks of enclosed superstructures shall be of substantial construction. The sills of the doorways shall be of the heights specified for hatchway coamings in Rules 18 and 25. The doors shall be strongly constructed and capable of being closed and secured from both sides. Where the companionway is situated within a quarter of the ship's length from the stem, it shall be of steel and riveted to the deck plating.

Companionways.

31.—(1) Ventilators in exposed positions on freeboard and superstructure decks to spaces below freeboard decks or decks of superstructures which are intact or fitted with Class 1 closing appliances shall have coamings of steel, substantially constructed, and efficiently connected to the deck by rivets spaced four diameters apart centre to centre, or by equally effective means. The deck plating at the base of the coaming shall be efficiently stiffened between the deck beams. The ventilator openings shall be provided with efficient closing arrangements.

(2) Where such ventilators are situated on the freeboard deck within a quarter of the ship's length from the stem, and the closing arrangements of the ventilators are of a temporary character, the coaming shall be at least 36 inches in height; in other exposed positions on the superstructure deck they are to be at least 30 inches in height. Where the coaming of any ventilator exceeds 36 inches in height, it shall be specially supported and secured.

32. Where the air pipes to ballast and other tanks extend above freeboard or superstructure decks, the exposed parts of the pipes shall be of substantial construction; the height from the deck to the opening shall be at least 36 inches in wells on freeboard decks, 30 inches on raised quarter decks, and 18 inches on other superstructure decks. Efficient means shall be provided for closing the openings of the air pipes.

#### OPENINGS IN THE SIDES OF SHIPS

33. Openings in the sides of ships below the freeboard deck shall be fitted with watertight doors or covers which, with their securing appliances, shall be of sufficient strength.

34.—(1) Discharges led through the ship's sides from spaces below the freeboard deck shall be fitted with efficient and accessible means for preventing water from passing inboard. Each separate discharge shall have either an automatic non-return valve with a positive means of closing it from a position above the freeboard deck, or two automatic non-return valves without positive means of closing, provided that the upper valve is situated so that it is always accessible for examination under service conditions. The positive action valve shall be readily accessible and is to be provided with means for showing whether the valve is open or closed.

(2) The foregoing provisions of this Rule shall apply to discharges from spaces within enclosed superstructures if, and to the extent that, the Assigning Authority consider necessary having regard to the type and location of the inboard ends of such openings.

(3) Where scuppers are fitted in superstructures not fitted with Class 1 closing appliances they shall have efficient means for preventing the accidental admission of water below the freeboard deck.

(4) Cast iron shall not be accepted for valve and discharges led through the ship's sides below the freeboard deck or through the sides of enclosed superstructures;

Provided that this requirement shall not apply to such valves and discharges in any ship the keel of which was laid before 1st January, 1947, unless in the case of valves these are attached to the sides of the ship.

35.—(1) Side scuttles to spaces below the freeboard deck, or to spaces below the superstructure deck of superstructures closed by Class 1 or Class 2 closing appliances, shall be fitted with efficient inside deadlights permanently attached in their proper positions so that they can be effectively closed and secured watertight.

(2) Where, however, such spaces in superstructures are appropriated to passengers, other than steerage passengers, or to crew, the side scuttles may have portable deadlights stowed adjacent to the side scuttles, provided they are readily accessible at all times on service.

(3) The side scuttles and deadlights shall be of substantial construction and of types approved by the Minister.

#### MISCELLANEOUS PROVISIONS

36. Efficient guard rails or bulwarks shall be fitted on all exposed portions of freeboard and superstructure decks.

Guard rails.

37.—(1) Where bulwarks on the weather portions of freeboard or superstructure decks form "wells", ample provision shall be made for rapidly freeing the decks of water and for draining them. The minimum freeing port area on each side of the ship for each "well" on freeboard decks and on raised quarter decks shall be that given by the following scale; the minimum area for each well on any superstructure deck other than a raised quarter deck shall be one half the area given by that scale. Where the length of the well exceeds seven-tenths of the length of the ship as defined in Rule 41 the Assigning Authority may modify that scale. In ships with less than the standard sheer the freeing port area shall be increased as required by the Assigning Authority.

Freeing ports.

#### Scale of Freeing Port Area

<i>Length of Bulwarks in well in Feet</i>	<i>Freeing Port Area on each side in Square Feet</i>
15	8.0
20	8.5
25	9.0
30	9.5
35	10.0
40	10.5
45	11.0
50	11.5
55	12.0
60	12.5
65	13.0
Above 65	1 square foot for each additional 5 feet length of bulwarks.

(2) The lower edges of the freeing ports shall be as near the deck as practicable and as a general rule shall not be higher than the upper edge of the gunwale bar. Two-thirds of the freeing port area required shall be provided in the midship half of the well.

(3) All such opening in the bulwarks shall be protected by rails or bars spaced about 9 inches apart. If shutters are fitted to freeing ports, ample clearance shall be provided to prevent jamming. Hinges shall have brass pins.

38.—(1) Gangways, lifelines or other satisfactory means shall be provided for the protection of the crew in getting to and from their quarters.

(2) The strength of houses for the accommodation of crew on flush deck ships shall be equivalent to that required for superstructure bulkheads.

Protection of crew.

Notwithstanding anything in the foregoing provisions of this Part of Rules, the Assigning Authority may, in any exceptional case, allow structures from the said provisions on condition that the freeboards computed for the ship are increased to such extent as will, in the opinion of the master, secure that the protection afforded to the ship and crew is not less extensive than it would be if the ship fully complied with the said provisions there had been no increase of freeboards.

Special provision for exceptional ships.

PART VI.—COMPUTATION OF FREEBOARDS FOR STEAMERS

40. Subject to the provisions of paragraph (c) of subsection (2) of section 3 of the Act and subject to the provisions of Rule 39 of these Rules, the freeboards for steamers, other than tankers or steamers of special type to which freeboards are assigned under Parts IX and X of these Rules, shall be computed in accordance with this Part of these Rules.

Freeboards for steamers.

41. The length (L) to be used with these Rules is the length in feet on the summer load water-line from the fore side of the stem to the after side of the rudder post. Where there is no rudder post, the length is measured from the fore side of the stem to the axis of the rudder stock. For ships with cruiser sterns, the length shall be taken as 96 per cent of the total length on the designed summer load water-line or as the length from the fore side of the stem to the axis of the rudder stock if that be the greater.

Length.

42. The breadth (B) to be used with these Rules is the maximum breadth in feet amidships to the moulded line of the frame in iron or steel ships, and to the outside of the planking in wood or composite ships.

Breadth.

43. The moulded depth is the vertical distance in feet, measured amidships, from the top of the keel to the top of the freeboard deck beam at the side. In wood or composite ships the distance is measured from the lower edge of the keel rabbet. Where the form at the lower part of the midship section is of a hollow character, or where thick garboards are fitted, the depth is measured from the point where the line of the flat of the bottom continued inwards cuts the side of the keel.

Moulded depth.

44.—(1) The depth (D) to be used with these Rules is the moulded depth plus the thickness of stringer plate, or plus  $T \frac{(L-S)}{L}$  if that be greater, where—

Depth for freeboard.

T is the mean thickness of the exposed deck clear of deck openings, and S is the total length of superstructures as defined in Rule 49.

(2) Where the topsides are of unusual form, D is the depth of a midships section having vertical topsides, standard round of beam and area of topside section equal to that in the actual midship section. Where there is a step or break in the topsides (e.g. as in a turret deck ship) 70 per cent of the area above the step or break is included in the area used to determine the equivalent section.

(3) In a ship without an enclosed superstructure covering at least 6L amidships, without a complete trunk or without a combination of intact partial superstructures and trunk extending all fore and aft, where D is less than  $\frac{L}{15}$ , the depth used with the table set out in Rule 49 shall not be taken as less than  $\frac{L}{15}$ .

45.—(1) The coefficient of fineness ( $c$ ) to be used with these Rules is given by the formula :—

$$c = \frac{35 \Delta}{L.B. d_1}$$

where  $\Delta$  is the ship's moulded displacement in tons (excluding bossing) at a mean moulded draught  $d_1$  which is 85 per cent of the moulded depth.

(2) The coefficient ( $c$ ) shall not be taken as less than .68.

#### STRENGTH

46.—(1) The Assigning Authority shall be satisfied with the structural strength of any ship before assigning to it a freeboard.

Strength to  
be adequate.

(2) Ships which comply with the highest standards of the rules of a Classification Society recognised for this purpose by the Minister, shall be regarded as having sufficient strength for the minimum freeboards allowed under these Rules.

(3) Ships which do not comply with the aforementioned standards shall be assigned such increased freeboards as shall be determined by the Assigning Authority, having regard to the extent to which the ship complies with the following strength moduli :—

(a) *Material*.—The strength moduli are based on the assumption that the structure is built of mild steel, manufactured by the open hearth process (acid or basic), and having a tensile strength of 26 to 32 tons per square inch, and an elongation of at least 16 per cent on a length of 8 inches.

(b) *Strength Deck*.—The strength deck is the uppermost deck which is incorporated into and forms an integral part of the longitudinal girder within the half-length amidships.

(c) *Depth to Strength Deck (Ds)*.—The depth to strength deck is the vertical distance in feet amidships from the top of the keel to the top of the strength deck beam at the side.

(d) *Draught (d)*.—the draught is the vertical distance in feet amidships from the top of the keel to the centre of the disc.

(e) *Longitudinal Modulus*.—The longitudinal modulus  $\frac{I}{y}$  is the moment of inertia  $I$  of the midship section about the neutral axis divided by the distance  $y$  measured from the neutral axis to the top of the strength deck beam at side, calculated in way of openings but without deductions for rivet holes. Areas are measured in square inches and distances in feet.

Below the strength deck, all continuous longitudinal members other than such parts of the under deck girders as are required entirely for supporting purposes, are included. Above the strength deck, the gunwale angle bar and the extension of the sheerstrake are the only members included.

The required longitudinal modulus for effective material is expressed by the formula  $f.d.B$ , where  $f$  is the factor obtained from the following table—

L.	f.	L.	f.
	1.80	360	9.40
100	2.00	380	10.30
120	2.35	400	11.20
140	2.70	420	12.15
160	3.15	440	13.10
180	3.60	460	14.15
200	4.20	480	15.15
220	4.80	500	16.25
240	5.45	520	17.35
260	6.20	540	18.45
280	6.95	560	19.60
300	7.70	580	20.80
320	8.55	600	22.00

For intermediate length, the value of  $f$  is determined by interpolation.

This formula applies where  $L$  does not exceed 600 feet,  $B$  is between  $\frac{L}{10} + 5$  and  $\frac{L}{10} + 20$ , both inclusive, and  $\frac{L}{D_s}$  is between 10 and 13.5, both inclusive.

(f) *Frame*—For the purpose of the frame modulus, the frame is regarded as composed of a frame angle and a reverse angle each of the same size and thickness.

(g) *Frame Modulus*—The modulus  $\frac{I}{y}$  of the midship frame below the lowest tier of beams is the moment of inertia  $I$  of the frame section about the neutral axis divided by the distance  $y$  measured from the neutral axis to the extremity of the frame section, calculated without deduction for rivet and bolt holes. The modulus is measured in inch units.

The required frame modulus is expressed by the formula—

$$\frac{s(d-t)(f_1 + f_2)}{1,000}$$

where—

$s$  is the frame spacing in inches ;

$t$  is the vertical distance in feet measured at amidships from the top of the keel to a point midway between the top of the inner bottom at side and the top of the heel bracket (see figure 4) ; where there is no double bottom,  $t$  is measured to a point midway between the top of the floor at centre and the top of the floor at side ;

$f_1$  is a coefficient depending on  $H$ , which, in ships fitted with double bottoms, is the vertical distance in feet from the middle of the beam bracket of the lowest tier of beams at side to a point midway between the top of the inner bottom at side and the top of the heel bracket. (See figure 4). Where there is no double bottom,  $H$  is measured to a point midway between the top of the floor at centre and the top of the floor at side. Where the frame obtains additional strength from the form of the ship, due allowance is made in the value of  $f_1$  ;

$f_2$  is a coefficient depending on  $K$ , which is the vertical distance in feet from the top of the lowest tier of beams at side to a point 7 feet 6 inches above the freeboard deck at side, or, if there is a superstructure, to a point 12 feet 6 inches above the freehold deck at side (see figure 4).

The values of  $f_1$  and  $f_2$  are obtained from the following tables—

H in feet	0	7	9	11	13	15	17	19	21	23	25
$f_1$	9	11	12.5	15	19	24	29.5	36	43	51	59

K in feet	0	5	10	15	20	25	30	35	40
$f_2$	0	0.5	1.0	2.0	3.0	4.5	6.5	9.0	12.0

Intermediate values are obtained by interpolation.

This formula applies where D is between 15 feet and 60 feet, both inclusive, B is between  $\frac{L}{10} + 5$  and  $\frac{L}{10} + 20$  both inclusive,  $\frac{L}{D}$  is between 10 and 13.5 both inclusive; and the horizontal distance from the outside of the frame to the centre of the first row of pillars does not exceed 20 feet.

In single deck ships of ordinary form, where H does not exceed 18 feet, the frame modulus determined by the preceding method is multiplied by the factor  $f_3$  where  $f_3 = .50 + .05(H-8)$ .

Where the horizontal distance from the outside of the frame to the centre of the first row of pillars exceeds 20 feet, sufficient additional strength shall be provided to the satisfaction of the Assigning Authority.

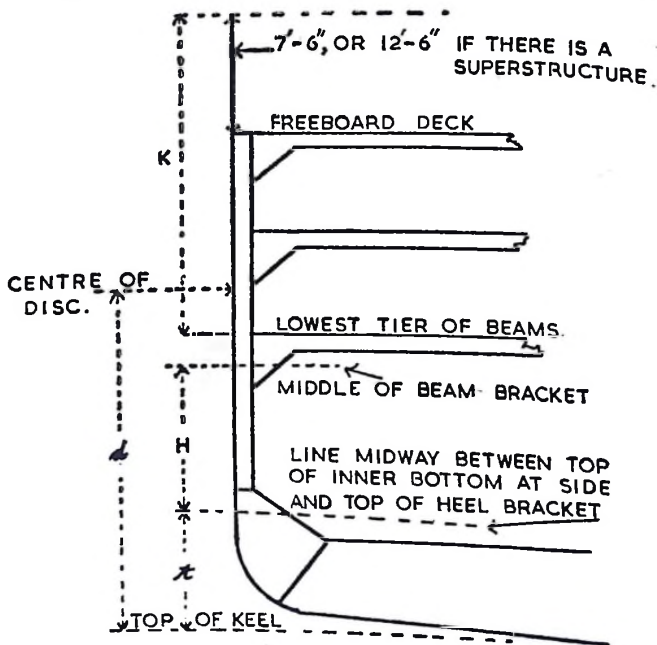

FIGURE 4.

## SUPERSTRUCTURES

B 398

Height of Super-structure.

Standard height.

Length of super-structure.

Enclosed super-structure.

Super-structure Bulkheads.

Class 1 closing appliances.

47. The height of a superstructure is the least vertical height measured from the top of the superstructure deck to the top of the freeboard deck beams minus the difference between D and the moulded depth as defined in Rules 43 and 44.

48. The standard height of a raised quarterdeck is 3 feet for ships up to and including 100 feet in length, 4 feet for ships 250 feet in length and 6 feet for ships 400 feet in length and above. The standard height at intermediate lengths is obtained by interpolation.

49. The length of a superstructure (S) is the mean covered length of the parts of the superstructure which extend to the sides of the ship and lie within lines drawn perpendicular to the extremities of the summer load water-line as defined in Rule 41.

50. A detached superstructure is regarded as enclosed only where—

- (i) the enclosing bulkheads are of efficient construction as required by Rule 51 ;
- (ii) the access openings in these bulkheads are fitted with Class 1 or Class 2 closing appliances (as defined in Rules 52 and 53) ;
- (iii) all other openings in sides or ends of the superstructure are fitted with efficient weathertight means of closing, and
- (iv) independent means of access to crew, machinery, bunker and other working spaces within bridges and poops are at all times available when the bulkhead openings are closed.

51. Bulkheads at exposed ends of poops, bridges and forecastles are deemed to be of efficient construction where the Assigning Authority are satisfied that, in the circumstances, they are equivalent to the following standard for ships with minimum freeboards, under which standard the stiffeners and plating are of the scantlings given in Table 3 in Appendix I to these Rules, the stiffeners are spaced 30 inches apart, the stiffeners on poop and bridge front bulkheads have efficient end connections, and those on after bulkheads of bridges and forecastles extend for the whole distance between the margin angles of the bulkheads.

### APPLIANCES FOR CLOSING ACCESS OPENINGS IN BULKHEADS AT ENDS OF DETACHED SUPERSTRUCTURES

52.—(1) Class 1 closing appliances shall be closing appliances which comply with the following conditions—

- (a) They shall be constructed of iron or steel ;
- (b) They shall in all cases be permanently and strongly attached to the bulkhead ;
- (c) They shall be framed, stiffened and fitted so that the whole structure is of equivalent strength to the unpierced bulkhead, and they shall be weathertight when closed.

(2) The means for securing these appliances shall be permanently attached to the bulkhead or to the appliances and the latter shall be so arranged that they can be closed and secured from both sides of the bulkhead or from the deck above. The sills of the access openings shall be at least 15 inches above the deck.

53. The following closing appliances shall be Class 2 closing appliances :—

Class 2  
closing  
appliances.

- (i) Strongly framed hard wood hinged doors, which are not more than 30 inches wide or less than 2 inches thick ;
- (ii) Shifting boards fitted for the full height of the opening in channels riveted to the bulkheads, the shifting boards being at least 2 inches thick where the width of opening is 30 inches or less, and increased in thickness at the rate of 1 inch for each additional 15 inches of width ;
- (iii) Portable plates of equal efficiency with the appliances specified in (i) or (ii).

#### TEMPORARY APPLIANCES FOR CLOSING OPENINGS IN SUPERSTRUCTURE DECKS

54. Temporary closing appliances for middle line openings in the deck of an enclosed superstructure shall be regarded as efficient if they consist of :—

Temporary  
closing  
appliances.

- (i) a steel coaming not less than 9 inches in height efficiently riveted to the deck ;
- (ii) hatchway covers as required by Rule 19, secured by hemp lashings ;
- (iii) hatchway supports as required by Rules 20 and 21 and Tables 1 or 2 in Appendix I to these Rules.

#### EFFECTIVE LENGTH OF DETACHED SUPERSTRUCTURE

55. For the purpose of determining the effective length of detached superstructures, Rules 56 to 61 shall apply.

56.—(1) Where exposed bulkheads at the ends of poops, bridges and fore-castles are not of efficient construction, they shall be treated as non-existent.

General.

(2) Where in the side plating of a superstructure there is an opening not provided with permanent means of closing, the part of the superstructure in way of the opening shall be regarded as having no effective length.

(3) Where the height of a superstructure is less than the standard, its length shall be reduced in the ratio of the actual to the standard height. Where the height exceeds the standard, no increase shall be made in the length of the superstructure.

57.—(1) Where there is an efficient bulkhead and the access openings are fitted with Class 1 closing appliances, the length of the poop to the bulkhead shall be the effective length.

Poop.

(2) Where the access openings in an efficient bulkhead are fitted with Class 2 closing appliances and the length of the poop to the bulkhead is .5L or less, 100 per cent of that length shall be the effective length ; where the length is .7L or more, 90 per cent of that length shall be the effective length ; where the length is between .5L and .7L an intermediate percentage of that length shall be the effective length ; but where in any of these cases an allowance is given for an efficient adjacent trunk (*see* Rule 61), only 90 per cent of the length to the bulkhead shall be the efficient length.

(3) 50 per cent of an open poop or of an open extension of a poop beyond an efficient bulkhead shall be the effective length of the open poop or extension, as the case may be.

B 400

Raised  
quarter-  
deck.

Bridge.

58. Where there is an efficient intact bulkhead, the length of the raised quarterdeck to the bulkhead shall be the effective length. Where the bulkhead is not intact, the superstructure shall be regarded as a poop of less than standard height.

59.—(1) Where there is an efficient bulkhead at each end of the bridge and the access openings in the bulkheads are fitted with Class 1 closing appliances, the length between the bulkheads shall be the effective length.

(2) Where the access openings in the forward bulkhead are fitted with Class 1 closing appliances and the access openings in the after bulkhead with Class 2 closing appliances, the length between the bulkheads shall be the effective length; but where an allowance is given for an efficient trunk adjacent to the after bulkhead (see Rule 61), 90 per cent of the length shall be the effective length. Where the access openings in both bulkheads are fitted with Class 2 closing appliances, 90 per cent of the length between the bulkheads shall be the effective length. Where the access openings in the forward bulkhead are fitted with Class 1 or Class 2 closing appliances and the access openings in the after bulkhead have no closing appliances, 75 per cent of the length between the bulkheads shall be the effective length. Where the access openings in both bulkheads have no closing appliances, 50 per cent of the length shall be the effective length.

(3) 75 per cent of the length of an open extension beyond the after bulkhead, and 50 per cent of that beyond the forward bulkhead, shall be the effective length.

Forecastle.

60.—(1) Where there is an efficient bulkhead and the access openings are fitted with Class 1 or Class 2 closing appliances, the length of the forecastle to the bulkhead shall be the effective length. Where no closing appliances are fitted and the sheer forward of amidships is not less than the standard sheer, 100 per cent of the length of the forecastle forward of .1L from the forward perpendicular shall be the effective length.

(2) Where the sheer forward is half the standard sheer or less, 50 per cent of the length shall be the effective length; and where the sheer forward is intermediate between the standard and half the standard sheer, an intermediate percentage of that length shall be the effective length.

(3) 50 per cent of the length of an open extension beyond the bulkhead or beyond .1L from the forward perpendicular shall be the effective length.

Trunks.

61.—(1) A trunk or similar structure which does not extend to the sides of the ship shall be regarded as efficient provided that—

(a) the trunk is at least as strong as a superstructure;

(b) the hatchways are in the trunk deck and comply with the requirements of Rules 17 to 24 and the width of the trunk deck stringer provides a satisfactory gangway and sufficient lateral stiffness;

(c) a permanent working platform fore and aft fitted with guard rails is provided by the trunk deck or by detached trunks connected to other superstructures by efficient permanent gangways;

(d) ventilators are protected by the trunk, by watertight covers or by equivalent means;

(e) open rails are fitted on the weather portions of the freeboard deck in way of the trunk for at least half their length;

(f) the machinery casings are protected by the trunk, by a superstructure of standard height, or by a deck house of the same height and of equivalent strength.

(2) Where access openings in poop and bridge bulkheads are fitted with Class 1 closing appliances, 100 per cent of the length of an efficient trunk reduced in the ratio of its mean breadth to B (as defined in Rule 42) shall be added to the effective length of the superstructures. Where the access openings in these bulkheads are not fitted with Class 1 closing appliances 90 per cent of the length reduced as above shall be added.

(3) Where the height of the trunk is less than the standard height as determined in accordance with Rule 48 the addition referred to in paragraph (2) of this Rule shall be reduced in the ratio of the actual to the standard height; where the height of the hatchway coamings on the trunk deck is less than the height required by Rule 18, a reduction from the actual height of trunk shall be made corresponding to the difference between the actual height of the coamings and the height required by Rule 18.

#### EFFECTIVE LENGTH OF ENCLOSED SUPERSTRUCTURES WITH MIDDLE LINE OPENINGS

62. Where there is an enclosed superstructure with one or more middle line openings in the deck not provided with permanent means of closing in accordance with Rules 17 to 24, the effective length of the superstructure is determined as follows—

Openings without permanent means of closing.

(i) where efficient temporary closing appliances are not provided for the middle line deck openings in accordance with Rule 54, or the breadth of opening is 80 per cent or more of the breadth ( $B_1$ ) of the superstructure deck at the middle of the opening, the ship shall be regarded as having an open well in way of each opening, and freeing ports shall be provided in way of this well. The effective length of superstructure between openings shall be ascertained by applying Rules 57, 59 and 60.

(ii) where efficient temporary closing appliances as defined in Rule 54 are provided for middle line deck openings and the breadth of opening is less than  $.8 B_1$  the effective length of superstructure between openings shall be ascertained by applying Rules 57, 59 and 60, except that where access openings in 'tween deck bulkheads are closed by Class 2 closing appliances, they shall be regarded as being closed by Class 1 closing appliances. The total effective length shall be obtained by adding to the length thus determined the difference between that length and the length of ship, modified in the ratio of—

$$\frac{B_1 - b}{B_1} \quad \text{where } b = \text{breadth of deck opening ;}$$

where  $\frac{B_1 - b}{B_1}$  is greater than .5 it is taken as .5.

#### DEDUCTIONS FOR SUPERSTRUCTURES

63. Where the effective length of superstructures is 1.0 L, the deduction from the freeboard shall be 14 inches at 80 feet length of ship, 34 inches at 280 feet length, and 42 inches at 400 feet length and above; deductions at intermediate lengths shall be obtained by interpolation. Where the total effective

Deductions.

length of superstructure is less than 1.0 L, the deduction shall be a percentage obtained from the following Table—

Superstructures	Total Effective Length of Superstructures (E)											Line
	0	.1L	.2L	.3L	.4L	.5L	.6L	.7L	.8L	.9L	1.0L	
	per cent	per	per	per	per	per	per	per	per	per	per	
All types with forecastle and without detached bridge .. .. .	0	5	10	15	23.5	32	46	63	75.3	87.7	100	A
All types with forecastle and detached bridge *	0	6.3	12.7	19	27.5	36	46	63	75.3	87.7	100	B

\*Where the effective length of a detached bridge is less than .2 L the percentages are obtained by interpolation between lines B and A.

Where no forecastle is fitted the above percentages are reduced by 5.

Percentages for intermediate lengths of superstructures are obtained by interpolation.

SHEER

General.

64.—(1) The sheer shall be measured from the deck at side to a line of reference drawn parallel to the keel through the sheer line at amidships.

(2) In flush deck ships and in ships with detached superstructures the sheer shall be measured at the freeboard deck.

(3) In ships with topsides of unusual form in which there is a step or break in the topsides, the sheer shall be considered in relation to the equivalent depth amidships determined in accordance with Rule 44.

(4) In ships with a superstructure of standard height which extends over the whole length of the freeboard deck, the sheer shall be measured at the superstructure deck ; where the height exceeds the standard, the sheer may be considered in relation to the standard height.

(5) Where a superstructure is intact or access openings in its enclosing bulkheads are fitted with Class 1 closing appliances, and the superstructure deck has at least the same sheer as the exposed freeboard deck, the sheer of the enclosed portion of the freeboard deck shall not be taken into account.

65. The ordinates, in inches, of the standard sheer profile are given in the following Table, where L is the number of feet in the length of the ship :—

Station	Ordinate	Factor
A.P.	.1 L+10	1
1/6 L from A.P.	.0445 L+4.45	4
1/3 L from A.P.	.011 L+1.1	2
Amidships	0	4
1/3 L from F.P.	.022 L+2.2	2
1/6 L from F.P.	.089 L+8.9	4
F.P.	.2 L+20	1

A.P.—After end of summer load water-line.  
 F.P.—Fore end of summer load water-line.

Standard sheer profile.

66.—(1) Where the sheer profile differs from the standard, the seven ordinates of each profile shall be multiplied by the appropriate factors given in table of ordinates. The difference between the sums of the respective products, divided by 18, measures the deficiency or excess of sheer.

Measurement of variations.

(2) Where the after half of the sheer profile is greater than the standard and the forward half is less than the standard, no credit shall be allowed for the part in excess.

(3) Where the forward half of the sheer profile exceeds the standard, and the after portion of the sheer profile is not less than 75 per cent of the standard, credit shall be allowed for the part in excess; where the after part is less than 50 per cent of the standard no credit shall be given for the excess sheer forward. Where the after sheer is between 50 and 75 per cent of the standard, an intermediate allowance may be granted for excess sheer forward.

67. The correction for sheer shall be the deficiency or excess of sheer determined in accordance with Rule 64, multiplied by  $.75 - \frac{S}{2L}$ , where S is the total length of superstructure, as defined in Rule 49.

Correction for Variations.

68. Where the sheer is less than the standard, the correction for deficiency in sheer, determined in accordance with Rule 67, shall be added to the freeboard.

Addition for deficiency.

69. In flush deck ships and in ships where an enclosed superstructure covers .1 L before and .1 L abaft amidships, the correction for excess of sheer determined in accordance with Rule 67, shall be deducted from the freeboard; in ships with detached superstructures where no enclosed superstructure covers less than .1 L before and .1 L abaft amidships, the deduction shall be obtained by interpolation. The maximum deduction for excess sheer shall be  $1\frac{1}{2}$  inches at 100 feet length of ship and shall increase at the rate of  $1\frac{1}{2}$  inches for each additional 100 feet in the length of the ship.

Deduction for Excess.

#### ROUND OF BEAM

70. The standard round of beam of the freeboard deck is one-fiftieth of the breadth of the ship.

Standard.

71. Where the round of beam of the freeboard deck is greater or less than the standard, the freeboard shall be decreased or increased respectively by one fourth of the difference between the actual and the standard round of beam, multiplied by the proportion of the length of the freeboard deck not covered by enclosed superstructures. Twice the standard round of beam is the maximum for which allowance may be given.

Correction.

#### MINIMUM FREEBOARDS

72. The minimum freeboard in summer shall be the freeboard derived from the Freeboard Table set out in Rule 77 after correction for departures from the standards and after deduction for superstructures in accordance with these Rules, so however that if the freeboard, calculated in accordance with these Rules but before the correction required by Note (v) appended to the Table is made, be less than two inches, two inches shall be substituted therefor.

Summer.

73. The minimum freeboard in the Tropical Zone shall be the freeboard obtained by a deduction from the Summer freeboard of  $\frac{1}{4}$  inch per foot of Summer draught measured from the top of the keel to the centre of the load

Tropical.

line disc, so however that if the freeboard, calculated in accordance with these Rules but before the correction required by Note (v) appended to the Table set out in Rule 77 is made, be less than two inches, two inches shall be substituted therefor.

Winter.

74. The minimum freeboard in Winter shall be the freeboard obtained by an addition to the Summer freeboard of  $\frac{1}{4}$  inch per foot of Summer draught, measured from the top of the keel to the centre of the load line disc.

Winter North Atlantic.

75. The minimum Winter North Atlantic freeboard for steamers not exceeding 330 feet in length shall be the Winter freeboard plus two inches; for steamers over 330 feet in length the minimum Winter North Atlantic freeboard shall be the Winter freeboard.

Fresh Water.

76.—(1) The minimum freeboard in fresh water of unit density shall be the freeboard obtained by deducting from the minimum freeboard in salt water—

$$\frac{\Delta}{40 T} \text{ inches, where}$$

$\Delta$  = displacement in salt water in tons at the summer load water-line, and  
 $T$  = tons per inch immersion in salt water at the summer load water-line.

(2) Where the displacement at the summer load water-line cannot be certified, the deduction shall be  $\frac{1}{4}$  inch per foot of summer draught measured from the top of the keel to the centre of the disc.

Freeboard Table.

77. Basic Minimum Summer Freeboards for Steamers which comply with Standards laid down in these Rules—

L	Free-board	L	Free-board	L	Freeboard	L	Freeboard
Feet	Inches	Feet	Inches	Feet	Inches	Feet	Inches
80	8.0	250	32.3	420	77.8	590	127.0
90	9.0	260	34.4	430	80.9	600	129.5
100	10.0	270	36.5	440	84.0	610	132.0
110	11.0	280	38.7	450	87.1	620	134.4
120	12.0	290	41.0	460	90.2	630	136.8
130	13.0	300	43.4	470	93.3	640	139.1
140	14.2	310	45.9	480	96.3	650	141.4
150	15.5	320	48.4	490	99.3	660	143.7
160	16.9	330	51.0	500	102.3	670	145.9
170	18.3	340	53.7	510	105.2	680	148.1
180	19.8	350	56.5	520	108.1	690	150.2
190	21.4	360	59.4	530	110.9	700	152.3
200	23.1	370	62.4	540	113.7	710	154.4
210	24.8	380	65.4	550	116.4	720	156.4
220	26.6	390	68.4	560	119.1	730	158.5
230	28.5	400	71.5	570	121.8	740	160.5
240	30.3	410	74.6	580	124.4	750	162.5

Note.—(i) The minimum freeboards for flush deck steamers shall be obtained by the addition to the above Table at the rate of  $1\frac{1}{2}$  inches for every 100 feet of length.

(ii) The freeboards at intermediate lengths shall be obtained by interpolation.

(iii) Where  $c$  exceeds .68, the freeboard shall be multiplied by the factor—

$$\frac{c + .68}{1.36}$$

(iv) (a) Where  $D$  exceeds  $\frac{L}{15}$  the freeboard shall be increased by—

$\left\{ D - \frac{L}{15} \right\} R$  inches, where  $R$  is  $\frac{L}{130}$  at lengths less than 390 feet, and 3 at 390 feet length and above.

(b) In a ship with an enclosed superstructure covering at least .6  $L$  amidships, or with a complete trunk, or with a combination of intact partial superstructures and trunk which extends all fore and aft, where  $D$  is less than

$\frac{L}{15}$ , the freeboard shall be reduced at the above rate. Where the height of

the superstructure or trunk is less than the standard height, as determined in accordance with Rule 48, the reduction shall be modified in the ratio which the actual height bears to the standard height.

(v) Where the actual depth to the surface of the freeboard deck amidships is greater or less than  $D$ , the difference between these two depths, in inches, shall be added to or deducted from the freeboard as the case may be.

## PART VII

### COMPUTATION OF FREEBOARDS FOR SAILING SHIPS

78. Subject to the provisions of paragraph (c) of subsection (2) of section 203 of the Act and subject to the provisions of Rule 39 and Rules 79 to 85 of these Rules, freeboards for sailing ships shall be computed from the Freeboard Table for Sailing Ships contained in Rule 84 in the same manner as the freeboards for steamers are computed from the Freeboard Table for Steamers contained in Rule 77.

Computation of Freeboard.

79.—(1) In sailing ships having a greater rise of floor than  $1\frac{1}{2}$  inches per foot, the vertical distance from the top of the keel referred to in Rule 43 shall be reduced by half the distance between the total rise of floor at the half-breadth of the ship and the total rise at  $1\frac{1}{2}$  inches per foot.  $2\frac{1}{2}$  inches per foot of half-breadth is the maximum rate of rise for which a deduction may be made.

Depth for Freeboard (D).

(2) Where the form at the lower part of the midship section is of a hollow character or thick garboards are fitted, the depth shall be measured from the point where the line of the flat of the bottom continued inwards cuts the side of the keel.

(3) The depth used with the Freeboard Table shall be taken as not less than  $\frac{L}{12}$

80. The coefficient of fineness ( $c$ ) used with the Freeboard Table contained in Rule 84 shall be taken as not less than .62 and not greater than .72.

Coefficient of Fineness.

B 406

Super-structures in wooden ships.

Deductions for Super-structures.

81. In wood ships, the Assigning Authority shall satisfy themselves as to the efficiency of the construction and closing arrangements of super-structures for which deductions are made from the freeboard.

82. Where the effective length of superstructures is 1.0 L, the deduction from the freeboard shall be 3 inches at 80 feet length of ship, and 28 inches at 330 feet length and above; deductions at intermediate lengths shall be obtained by interpolation. Where the total effective length of super-structures is less than 1.0 L, the deduction shall be a percentage obtained from the following Table :-

Type of superstructures	Total Effective Length of Superstructures (E)										Line	
	0	.1L	.2L	.3L	.4L	.5L	.6L	.7L	.8L	.9L		1.0L
	%	%	%	%	%	%	%	%	%	%	%	
All types without bridge	0	7	13	17	23.5	30	47.5	70	80	90	100	A
All types with bridge * ...	0	7	14.7	22	32	42	56	70	80	90	100	B

\* Where the effective length of bridge is less than .2 L, the percentages are obtained by interpolation between lines B and A. Percentages for intermediate lengths of superstructures are obtained by interpolation.

Minimum Freeboards.

83. (1) No addition to the freeboard shall be required for Winter freeboard, nor shall a deduction be permitted for Tropical freeboard.

(2) An increase in freeboard of 3 inches shall be made for the Winter North Atlantic freeboard.

(3) In computing the Fresh Water freeboard for a wood ship, the draught shall be measured from the lower edge of the rabbet of the keel to the centre of the load line disc.

Freeboard Table for Sailing Ships.

84. Minimum Summer, Winter and Tropical Freeboards for Iron and Steel Flush Deck Sailing Ships, which comply with the Standards laid down in these Rules—

L	Free-board	L	Free-board	L	Free-board	L	Free-board
Feet	Inches	Feet	Inches	Feet	Inches	Feet	Inches
80	9.2	140	21.3	200	35.4	270	53.5
90	11.0	150	23.5	210	37.9	280	56.3
100	12.9	160	25.8	220	40.4	290	59.1
110	14.9	170	28.2	230	42.9	300	61.9
120	17.0	180	30.6	240	45.5	310	64.7
130	19.1	190	33.0	250	48.1	320	67.6
				260	50.8	330	70.5

Note (i) The freeboards at intermediate lengths shall be obtained by interpolation.

(ii) Where c exceeds .62 the freeboard shall be multiplied by the factor

$$\frac{c + .62}{1.24}$$

(iii) Where  $D$  exceeds  $\frac{L}{12}$  the freeboard shall be increased by

$$\left\{ D - \frac{L}{12} \right\} \times \left\{ 1 + \frac{L}{250} \right\} \text{ inches.}$$

(iv) Where the actual depth to the surface of the freeboard deck amidships is greater or less than  $D$ , the difference between these two depths, in inches, shall be added to or deducted from the freeboard, as the case may be.

85. The freeboard for a wood sailing ship shall be the minimum freeboard which would be assigned to the ship if she were of iron or steel, with the addition of such amount of freeboard as the Assigning Authority may determine, having regard to the classification, construction, age and condition of the ship.

Freeboard  
for Wood  
Sailing  
Ships.

## PART VIII

### FREEBOARDS FOR STEAMERS CARRYING TIMBER DECK CARGOES

86. Timber freeboards shall be assigned to a steamer if the steamer, being otherwise entitled to have freeboards assigned to her, complies with this Part of these Rules to the extent required in her case.

Assignment.

### SUPPLEMENTARY CONDITIONS OF ASSIGNMENT

87. The structure of the steamer shall be of sufficient strength for the deeper draught allowed and for the weight of the deck cargo.

Construc-  
tion.

88. The steamer shall have a forecastle of at least standard height and at least 7 per cent of the length of the ship, and, in addition, a poop, or a raised quarter deck with a strong steel hood or deck house fitted aft :

Super-  
structures.

Provided that a steamer the keel of which was laid before 1st July, 1932, need comply with the foregoing provisions of this Rule only so far as, in the opinion of the Assigning Authority, is reasonable and practicable.

89. Machinery casing on the freeboard deck shall be protected by a superstructure of at least standard height, unless the machinery casings are of sufficient strength and height to permit of the carriage of timber alongside.

Machinery  
Casings.

90. Double bottom tanks where fitted within the midship half length of the steamer shall have adequate longitudinal subdivision.

Double  
Bottom  
Tanks.

91. The steamer shall be fitted either with permanent bulwarks at least 3 feet 3 inches high, specially stiffened on the upper edge and supported by strong bulwark stays attached to the deck in the way of the beams and provided with necessary freeing ports, or, with efficient rails at least 3 feet 3 inches high and of specially strong construction.

Bulwarks.

92. Steering arrangements shall be effectively protected from damage by cargo, and, as far as practicable, shall be accessible. Efficient provision shall be made for steering in the event of a breakdown in the main steering arrangements.

Steering  
Arrange-  
ments.

93. Eye plates for lashings shall be riveted to the sheer strake at intervals of not more than 10 feet, the distance from an end bulkhead of a superstructure to the first eyeplate being not more than 6 feet 6 inches. Additional eyeplates may be fitted on the stringer plate.

#### COMPUTATION OF FREEBOARD

Computation.

94. (1) Where the Assigning Authority is satisfied that the steamer is suitable and that the conditions and arrangements are at least equal to the foregoing requirements for the carriage of timber deck cargo, the Summer freeboards computed in accordance with the Rules and Tables in Part VI may be modified to give special timber freeboards, by substituting the following percentages for those in Rule 63.

Types	Total Effective Length of Superstructures (E).										
	0	.1L	.2L	.3L	.4L	.5L	.6L	.7L	.8L	.9L	1.0L
All types	% 20	% 30.75	% 41.5	% 52.25	% 63	% 69.25	% 75.5	% 81.5	% 87.5	% 93.75	% 100

(2) The Winter Timber freeboard shall be obtained by adding to the Summer Timber freeboard one-third of an inch per foot of moulded Summer Timber draught.

(3) The Winter North Atlantic Timber freeboards shall be identical with the Winter North Atlantic freeboards prescribed in Rule 75.

(4) The Tropical Timber freeboard shall be obtained by deducting from the Summer Timber freeboard one-quarter of an inch per foot of the moulded Summer Timber draught.

Special Cases.

95. In the case of a steamer the keel of which was laid before the 1st July, 1932, which does not fully comply with the requirements of Rule 88, the Assigning Authority shall make such addition to the freeboard as may be considered reasonable by the Minister, having regard to the extent to which the steamer falls short of full compliance with those requirements.

#### PART IX—FREEBOARDS FOR TANKERS

Assignment.

96. Tanker freeboards shall be assigned to a ship, being a tanker, if the ship complies with the Conditions of Assignment and also complies with this Part of these Rules to the extent thereby required in her case.

#### SUPPLEMENTARY CONDITIONS OF ASSIGNMENT

Construction.

97. The structure of the ship shall be of sufficient strength for the increased draught corresponding to the freeboard assigned.

Forecastle.

98. The ship shall have a forecastle of which the length is not less than 7 per cent of the length of the ship and the height is not less than the standard height.

Provided that a ship the keel of which was laid before 1st July, 1932, need comply with the foregoing provisions of this Rule only so far as, in the opinion of the Assigning Authority, is reasonable and practicable.

99. The openings in machinery casings on the freeboard deck shall be fitted with steel doors. The casings shall be protected by an enclosed poop or bridge of at least standard height, or by a deck house of equal height and of equivalent strength. The bulkheads at the ends of these structures shall be of the scantlings required for bridge front bulkheads. All entrances to the structures from the freeboard deck shall be fitted with effective closing appliances and the sills shall be at least 18 inches above the deck. Exposed machinery casings on the superstructure deck are to be of substantial construction, and all openings in them shall be fitted with steel closing appliances permanently attached to the casings and capable of being closed and secured from both sides; the sills of such openings shall be at least 15 inches above the deck. Fiddle openings shall be as high above the superstructure deck as is reasonable and practicable and shall have strong steel covers permanently attached in their proper positions:

Machinery Casings.

Provided that a ship the keel of which was laid before 1st July, 1932 need comply with the foregoing provisions of this Rule only so far as, in the opinion of the Assigning Authority, is reasonable and practicable.

100. An efficiently constructed permanent gangway of sufficient strength for its exposed position shall be fitted fore and aft of the level of the superstructure deck between the poop midship bridge, and when any of the crew are berthed forward, from the bridge to the forecastle, unless other equivalent means of access are provided to carry out the purpose of the gangway, such as passages below deck.

Gangway.

101. Safe and satisfactory access from the gangway level to the quarters of the crew, the machinery space and all other parts used in the necessary work of the ship, shall be available at all times. This Rule does not apply to pump rooms if suitable means of access are provided from the freeboard deck, and the access openings are fitted with Class 1 closing appliances.

Protection of Crew, etc.

102. All hatchways on the freeboard deck and on the deck of expansion trunks shall be closed watertight by efficient steel covers.

Hatchways.

103. Ventilators to spaces below the freeboard deck shall be of ample strength or shall be protected by superstructures or by equally efficient means.

Ventilators.

104.—(1) Ships with bulwarks shall have open rails fitted for at least half the length of the exposed portion of the weather deck or such other freeing arrangements as are in the opinion of the Assigning Authority effective for the purpose of freeing the decks of water. The upper edge of the sheer strake shall be kept as low as practicable, and as a general rule shall not be higher than the upper edge of the gunwale bar.

Freeing Arrangements.

(2) Where superstructures are connected by trunks, open rails shall be fitted for the whole length of the weather portions of the freeboard deck;

Provided that a ship the keel of which was laid before 1st July, 1932, need comply with the foregoing provisions of this Rule only so far as, in the opinion of the Assigning Authority, is reasonable and practicable.

#### COMPUTATION OF FREEBOARD

105. Where the Assigning Authorities are satisfied that the foregoing requirements are fulfilled, they shall compute the freeboards in accordance with Part VI of these Rules, subject to the provisions of Rules 106 to 108 and to the substitution of the Table set out in Rule 109 for the Table set out in Rule 77:

Computation.

B 410

Provided, however, that no addition shall be made under Note (i) appended to the Table in Rule 77 in respect of a flush deck steamer.

Deduction for detached Super-structures.

106. When the total effective length of superstructures is less than 1.0 L, the deduction shall be the percentage of the deduction for a superstructure of length 1.0 L, obtained from the following Table :—

	Total Effective Length of Superstructures.										
	0	.1L	.2L	.3L	.4L	.5L	.6L	.7L	.8L	.9L	1.0L
All types	% 0	% 7	% 14	% 21	% 31	% 41	% 52	% 63	% 75.3	% 87.7	% 100

Deduction for excess sheer.

107. Where the sheer is greater than the standard, the correction for excess sheer as determined under Rule 67 shall be deducted from the freeboard of all tankers. Rule 69 shall not apply except that the maximum deduction for excess sheer shall be  $1\frac{1}{2}$  inches at 100 feet length of ship and shall increase at the rate of  $1\frac{1}{2}$  inches for each additional 100 feet in the length of the ship.

Winter North Atlantic.

108. The minimum Winter North Atlantic freeboard shall be the Winter freeboard plus an addition at the rate of 1 inch per 100 feet in length.

Freeboard Table for Tankers.

109. Freeboard Table for Tankers :—

L Feet	Freeboard Inches	L Feet	Freeboard Inches
190	21.5	400	62.5
200	23.1	410	64.9
210	24.7	420	67.4
220	26.3	430	69.9
230	28.0	440	72.5
240	29.7	450	75.1
250	31.5	460	77.7
260	33.3	470	80.2
270	35.2	480	82.7
280	37.1	490	85.1
290	39.1	500	87.5
300	41.1	510	89.8
310	43.1	520	92.1
320	45.1	530	94.3
330	47.1	540	96.5
340	49.2	550	98.6
350	51.3	560	100.7
360	53.5	570	102.7
370	55.7	580	104.6
380	57.9	590	106.5
390	60.2	600	108.4

The freeboards for ships above 600 feet shall be determined by the Minister

110. In the case of any ship the keel of which was laid before the 1st July, 1932, which does not fully comply with the requirements of Rules 98, and 104, the Assigning Authority shall make such addition to the freeboard as may be considered reasonable by the Minister, having regard to the extent to which the ship falls short of full compliance with those requirements.

Special provision.

#### PART X.—FREEBOARDS FOR SHIPS OF SPECIAL TYPE

111.—(1) In the case of steamers of special type over 300 feet in length possessing constructional features similar to those of a tanker which, in the opinion of the Minister afford extra invulnerability against the sea, a reduction in the freeboard computed for steamers under Part VI may be granted.

Freeboards in special cases.

(2) The amount of such reduction shall be determined by the Minister with reference to the freeboard assigned to tankers, having regard to the extent to which the steamer complies with the Conditions of Assignment and with the requirements of Part IX of these Rules and the degree of subdivision provided in the ship, but the freeboard assigned to such a ship shall in no case be less than the freeboard which would be assigned to her if she were a tanker.

#### PART XI.—LOAD LINE

112.—(1) This Rule shall apply to all steamers other than steamers to which Rule 114 applies.

Steamers.

(2) *Summer Load Line*—The maximum depth in salt water to which a steamer to which this Rule applies is entitled to be loaded while within :—

(a) The Summer Zone as defined in the First Part of the Third Schedule thereto, and

Third Schedule.

(b) the areas specified in the first two columns of the Second and Third Parts of the said Schedule during the periods specified respectively opposite to such areas in the third column of the said Second and Third Parts of the said Schedule

shall be the depth indicated by the Summer load line.

(3) *Winter Load Line*—Save as is hereinafter provided, the maximum depth in salt water to which a steamer to which this Rule applies is entitled to be loaded while within the areas specified in the first two columns of the Second Part of the Third Schedule hereto during the periods specified respectively opposite to such areas in the fourth column of the said Second Part of the said Schedule shall be the depth indicated by the Winter load line :

Provided that in the case of a steamer required to be marked with a Winter North Atlantic load line under Part III of these Rules, the maximum depth in salt water to which such steamer is entitled to be loaded whilst engaged on a voyage across the North Atlantic Ocean within the areas numbered 1 and 2 in the first column of the said Second Part of the said Schedule during the periods specified respectively opposite to those areas in the fourth column to the said Second Part of the said Schedule shall be the depth indicated by such Winter North Atlantic load line.

(4) *Tropical Load Line*—The maximum depth in salt water to which a steamer to which this Rule applies is entitled to be loaded while within :—

(a) the Tropical Zone as defined in the First Part of the Third Schedule hereto, and

(b) the areas specified in the first two columns of the Third Part of the Third Schedule hereto during the periods respectively specified opposite those areas in the fourth column of the said Third Part, shall be the depth indicated by the Tropical load line.

Sailing ships.

113. The maximum depth in salt water to which a sailing ship is entitled to be loaded is the depth indicated by the upper edge of the line which passes through the centre of the disc, except when engaged on a voyage across the Atlantic Ocean within the areas numbered 1 and 2 in the first column of the Second Part of the Third Schedule hereto, during the periods specified respectively opposite to those areas in the fourth column of the said Second Part of the said Schedule in which case it shall be the depth indicated by the Winter North Atlantic load line.

Steamers carrying timber deck cargoes.

114.—(1) This Rule shall apply to all steamers marked with Timber load lines in accordance with Part VIII of these Rules and carrying a deck cargo of timber in compliance with the Timber Cargo Regulations.

(2) *Summer Timber Load Line*—The maximum depth in salt water to which a steamer to which this Rule applies is entitled to be loaded while within—

(a) The Summer Zone as defined in the First Part of the Third Schedule hereto, and

(b) the areas specified in the first two columns of the Second and Third Parts of the said Schedule during the periods respectively specified opposite to such areas in the third column of the Second and Third Parts of the said Schedule,

shall be the depth indicated by the Summer Timber load line.

(3) *Winter Timber Load Line*—The maximum depth in salt water to which a steamer to which this Rule applies other than a steamer to which paragraph (4) of this Rule applies, is entitled to be loaded while within the areas specified in the first two columns of the Second Part of the Third Schedule hereto during the periods respectively specified opposite to such areas in the fourth column of the said Second Part of the said Schedule, shall be the depth indicated by the Winter Timber load line.

(4) *Winter North Atlantic Timber Load Line*—The maximum depth in salt water to which a steamer to which this Rule applies is entitled to be loaded whilst engaged on a voyage across the North Atlantic Ocean within the areas numbered 1 and 2 in the first column of the Second Part of the said Schedule during the periods specified respectively opposite to those areas in the fourth column of the said Second Part, shall be the depth indicated by the Winter North Atlantic Timber load line.

(5) *Tropical Timber Load Line*—The maximum depth in salt water to which a steamer to which this Rule applies is entitled to be loaded while within—

(a) the Tropical Zone as defined in the First Part of the Third Schedule hereto, and

(b) the areas specified in the first two columns of the Third Part of the said Schedule during the periods respectively specified opposite those areas in the fourth column of the said Third Part shall be the depth indicated by the Tropical Timber load line.

115. In the application of the foregoing Rules 112 to 114 to a ship at a port which is to be treated under the Third Schedule hereto as being on the boundary between two zones, two areas, or a zone and an area, the ship shall be deemed to be in the zone or area into which she is about to proceed or from which she has arrived, as the case may be.

Boundary  
ports.

PART XII.—LOAD LINES FOR STEAMERS PLYING ON INLAND WATERS ONLY

116. A load line, indicating the minimum freeboard allowed, shall be assigned to any steamer exclusively employed on inland waters and which is subject to the provisions of section 229 of the Act. Such load line shall consist of a horizontal line 12 inches in length and one inch in breadth, marked on each side of the vessel amidships. The upper edge of such line shall indicate the deepest draught that the vessel may be loaded in any of the inland waters of Nigeria. Load lines shall be cut in or otherwise permanently marked on the hull and they shall be painted white or yellow on a dark ground or black on a light ground.

Load Line.

117. The depth of a vessel for the purposes of this Part shall, in the case of a Power Driven Small Craft be measured amidships in a vertical line from the upper edge of the gunwale to the lowest part of the bottom at centre. The gunwale in this case is to be taken as the upper edge of hull of the craft, except that where wash boards or other planks have been fitted to the hull and extend above the true hull, the depth shall be taken from the upper edge of such wash boards or planks. In the case of craft other than Power Driven Small Craft, the depth shall be measured amidships in a vertical line from the upper edge of the gunwale or sheer strake to the top of the keel at centre.

Depth.

118. The survey for the load line shall normally take place concurrently with the survey for a Passenger Certificate or a Safety Certificate or a combined Passenger and Safety Certificate, or a Power Driven Small Craft Licence. At such time, the surveyor shall ascertain the position of the load line and shall indicate such position to the owner who shall cause the proper marks to be made on the vessel to the satisfaction of the surveyor.

Position  
of load  
line.

119.—(1) The position of the load line for Power Driven Small Craft shall be ascertained by allowing 4 inches of freeboard from the gunwale downwards for each foot or part thereof of depth measured in accordance with Rule 117.

Freeboard.

(2) The position of the load line for vessels other than Power Driven Small Craft shall be ascertained by allowing 4 inches of freeboard from the gunwale or upper edge of the sheer strake downwards for every foot or part thereof of depth measured in accordance with Rule 117. Provided that in the case of a fully decked vessel fitted with adequate coamings round all deck openings and hatchways fitted with efficient closing appliances, the freeboard allowed may be reduced to two inches per foot or part thereof of depth.

120.—(1) As in the case of inland waters craft, the assignment of load lines is combined with Passenger and/or Safety Certificates it follows that no such certificates will be issued unless the surveyor is satisfied that the vessel

Conditions  
of assign-  
ment.

is properly constructed and fitted for the trade in which she is to engage, is properly fitted with guard rails where required and that, except in the case of Power Driven Small Craft, the machinery space is adequately insulated from the other compartments.

(2) In abnormally constructed vessels, where the surveyor is not satisfied that the normal freeboard calculation as set out in Rule 119 would suit that type of craft, having regard to the safety of the vessel, he shall transmit the facts of the case along with his recommendations to the Minister, who will, if he thinks fit, assign a special freeboard to suit the case.

121. The Government Inspector of Shipping may exempt any inland waters ship from full compliance with these rules, to the extent to which he is satisfied that compliance therewith is unreasonable or impracticable in the circumstances.

122. Anything required to be done by the Minister under these Rules may be done by the Government Inspector of Shipping acting on the Minister's behalf.

## FIRST SCHEDULE

### FEEs

1. SEA-GOING SHIPS. SEE FEES REGULATIONS PART VI

2. INLAND WATERS VESSELS.

As the survey of inland waters vessels will normally be carried out at the same time as the survey for the issue of a Passenger and/or Safety Certificate or a Power Driven Small Craft Licence, no separate fee will be charged. Where, however, for any reason, the survey for load line is carried out separately from the other surveys the following fees will be charged—

Type of vessel		Fee		
		£	s	d
All Power Driven Small Craft		1	5	0
<i>Other Vessels</i>				
Under 20 tons	.. .. .	10	0	0
20 and under 50 tons	.. .. .	12	10	0
50 " " 100 "	.. .. .	17	10	0
100 " " 300 "	.. .. .	25	0	0
300 " " 600 "	.. .. .	31	5	0
600 and above	.. .. .	37	10	0

Gross Tonnage	CLASSED SHIPS			UNCLASSED SHIPS		
	Fees			Fees		
	(1) Issue	(2) Re- newal Survey	(3) Annual Survey	(4) Issue	(5) Re- newal Survey	(6) Annual Survey
Under 50 tons	£ 11	£ 5	£ 5	£ 25	£ 25	£ 4
50 and under 100	12	5	5	47	47	8
100 " " 300	19	5	5	62	62	8
300 " " 500	25	9	9	86	86	11
500 " " 1,000	31	11	11	116	116	16
1,000 " " 1,500	39	14	14	150	150	20
1,500 " " 2,000	44	15	15	172	172	24
2,000 " " 2,500	49	17	17	196	196	24
2,500 " " 3,000	54	19	19	219	219	27
3,000 " " 4,000	57	20	20	242	242	31
4,000 " " 5,000	64	20	20	266	266	31
5,000 " " 6,000	69	20	20	290	290	31
6,000 " " 7,000	74	21	21	312	312	31
7,000 " " 8,000	77	21	21	336	336	31
8,000 " " 9,000	80	22	22	360	260	31
9,000 " " 10,000	82	24	24	384	384	31
10,000 tons and above	82	24	24	£24	£24	31
				for every addi- tional 1,000 tons	for every addi- tional 1,000 tons	

#### VARIATIONS OF STANDARD FEES

(1) For every annual survey of any ship over 300 tons (classed or unclassified) which is carried through in one operation there shall be paid—

(a) the standard fee, and

(b) in addition, a single fee of £8-0s if, for the purposes of the survey, more than one visit is paid to the ship by the surveyor.

(2) For every annual survey of any ship (classed or unclassified) which is not carried through in one operation there shall be paid—

(a) the standard fee,

(b) in addition, a fee of £8-0s for every partial annual survey, and

(c) for any ship over 300 tons, in addition, a single fee of £15 for every partial annual survey in respect of which, for the purposes of the partial annual survey, more than one visit is paid to the ship by the surveyor.

(3) In the case of a survey of a classed ship for renewal of the Load Line Certificate, the fee in column (2) shall be paid if the renewal is carried out concurrently with a Special Survey for classification purposes, for which a fee is charged. Otherwise the fee will be 50 per cent of that in column (1).

(4) Where the survey for the issue or renewal of a Load Line Certificate is carried out by a Ministry surveyor concurrently with that for a Passenger and Safety Certificate, and the ship is—

(a) a classed ship—no fee will be charged under column (1) or column (2);

(b) an unclassified ship—half the fee under column (4) or column (5) shall be paid.

(5) Where the annual load line survey is made by a Ministry surveyor at the same time as the survey for the issue of a Passenger or Passenger and Safety Certificate, no fee will be charged under column (3) or column (6).

(6) Where minor alterations have been made to a ship having a Load Line Certificate in force, which involve an alteration of the freeboard but do not require a full survey, the fee in column (2) shall be paid whether the ship be classed or unclassified.

(7) Where for special reasons a partial survey is made and a certificate is issued or renewed for a period not exceeding twelve months, one-half of the standard fee appropriate to a full survey shall be paid.

SECOND SCHEDULE

Rule 15

FORMS OF LOAD LINE CERTIFICATES

Form M. of T.—LL.1

INTERNATIONAL LOAD LINE CERTIFICATE

Issued under the authority of the Federal Government of Nigeria, under the provisions of the International Load Line Convention, 1930

Ship's Name		Official Number	
Port of Registry			
Gross Tonnage			
	Freeboard from Deck Line		Load Line
Tropical	feet	inches (T)	inches above S.
Summer	feet	inches (S)	Upper edge of line through centre of disc.
Winter	feet	inches (W)	inches below S.
Winter North Atlantic	feet	inches (WNA)	inches below S.
Allowance for Fresh Water for all freeboards			inches.

The upper edge of the deck line from which these freeboards are measured  
 is \_\_\_\_\_ inches above the top of the \_\_\_\_\_ deck at side.

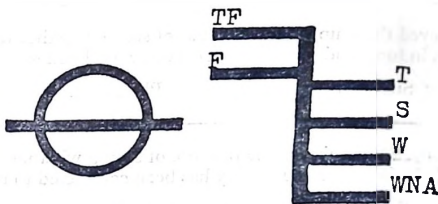

This is to certify that this ship has been surveyed and the freeboards and load lines shown above have been assigned in accordance with the Convention.

This Certificate remains in force until \_\_\_\_\_

Issued at \_\_\_\_\_ on the \_\_\_\_\_ day of \_\_\_\_\_ 19 \_\_\_\_\_

Signature and description.

*Note*—Where sea-going steamers navigate a river or inland water, deeper loading is permitted corresponding to the weight of fuel, etc., required for consumption between the point of departure and the open sea.

I have surveyed this ship for the purpose of seeing whether this Certificate should remain in force and the Survey has been completed to my satisfaction.

Signature of Surveyor \_\_\_\_\_ Place \_\_\_\_\_ Date \_\_\_\_\_

---

I have surveyed this ship for the purpose of seeing whether this Certificate should remain in force and the Survey has been completed to my satisfaction.

Signature of Surveyor \_\_\_\_\_ Place \_\_\_\_\_ Date \_\_\_\_\_

---

I have surveyed this ship for the purpose of seeing whether this Certificate should remain in force and the Survey has been completed to my satisfaction.

Signature of Surveyor \_\_\_\_\_ Place \_\_\_\_\_ Date \_\_\_\_\_

---

I have surveyed this ship for the purpose of seeing whether this Certificate should remain in force and the Survey has been completed to my satisfaction.

Signature of Surveyor ..... Place ..... Date.....

The provisions of the Convention being fully complied with by this ship, this Certificate is renewed till.

Place ..... Signature and description.  
Date 19 .

I have surveyed this ship for the purpose of seeing whether this Certificate should remain in force and the Survey has been completed to my satisfaction.

Signature of Surveyor ..... Place ..... Date.....

I have surveyed this ship for the purpose of seeing whether this Certificate should remain in force and the Survey has been completed to my satisfaction.

Signature of Surveyor ..... Place ..... Date.....

I have surveyed this ship for the purpose of seeing whether this Certificate should remain in force and the Survey has been completed to my satisfaction.

Signature of Surveyor ..... Place ..... Date.....

I have surveyed this ship for the purpose of seeing whether this Certificate should remain in force and the Survey has been completed to my satisfaction.

Signature of Surveyor ..... Place ..... Date.....

#### NOTES

1. This Certificate must be kept framed and posted up in some conspicuous part of the ship so long as it remains in force, and the ship is in use.
2. The Winter North Atlantic load line applies for voyages across the North Atlantic, North of Latitude 36° N., during the winter months as defined by the Load Line Rules. The periods during which the other seasonal load lines apply in different parts of the world are as stated in the Load Line Rules.
3. This Certificate will be cancelled by the Minister if—
  - (a) material alterations have taken place in the hull or superstructures of the ship which affect the position of the load lines, or
  - (b) the fittings and appliances for the protection of openings, the guard rails, the freeing ports or the means of access to the crew's quarters have not been maintained on the ship in as effective a condition as they were in when the Certificate was issued; or
  - (c) the periodical survey is not made as required by the Load Line Rules.

4. Where this Certificate has expired or been cancelled, it must be delivered up to the Assigning Authority and the ship may be detained until such requirement has been complied with, and if any owner or master fails without reasonable cause to comply with such requirement, he shall for each offence be liable to a fine not exceeding one hundred pounds.

*Appliances for closing access openings in bulkheads at ends of detached superstructures*

Forecastle .. .. .	
Bridge Fore End .. .. .	
Bridge After End .. .. .	
Raised Quarter Deck .. .. .	
Poop .. .. .	
<i>Temporary appliances for closing openings in superstructure decks</i>	

Form M. of T.—LL.2

INTERNATIONAL LOAD LINE CERTIFICATE

Issued under the authority of the Federal Government of Nigeria,  
under the provisions of the International Load Line Convention, 1930

Ship's Name  
Port of Registry  
Registered Tonnage

Official Number

Freeboard from Deck Line  
Tropical } feet inches  
Summer }  
Winter }

Load Line  
Upper edge of line  
through centre of disc.

Winter North Atlantic feet inches (WNA)

inches below  
Upper edge of line  
through centre of disc.  
inches

Allowance for fresh water for all freeboards

The upper edge of the deck line from which these freeboards are measured  
is inches above the top of the deck at side.



WNA

This is to certify that this ship has been surveyed and the freeboards and load lines shown above have been assigned in accordance with the Convention.

This Certificate remains in force until  
Issued at on the day of 19 .

Signature and description.

Note.—Where sea-going steamers navigate a river or inland water, deeper loading is permitted corresponding to the weight of fuel, etc., required for consumption between the point of departure and the open sea.

I have surveyed this ship for the purpose of seeing whether this Certificate should remain in force and the Survey has been completed to my satisfaction.

Signature of Surveyor ..... Place ..... Date.....

I have surveyed this ship for the purpose of seeing whether this Certificate should remain in force and the Survey has been completed to my satisfaction.

Signature of Surveyor ..... Place ..... Date.....

I have surveyed this ship for the purpose of seeing whether this Certificate should remain in force and the Survey has been completed to my satisfaction.

Signature of Surveyor ..... Place ..... Date.....

I have surveyed this ship for the purpose of seeing whether this Certificate should remain in force and the Survey has been completed to my satisfaction.

Signature of Surveyor ..... Place ..... Date.....

The provisions of the Convention being fully complied with by this ship, this Certificate is renewed until

Place

Date

19

Signature and description.

I have surveyed this ship for the purpose of seeing whether this Certificate should remain in force and the Survey has been completed to my satisfaction.

Signature of Surveyor ..... Place ..... Date .....

I have surveyed this ship for the purpose of seeing whether this Certificate should remain in force and the Survey has been completed to my satisfaction.

Signature of Surveyor ..... Place ..... Date .....

I have surveyed this ship for the purpose of seeing whether this Certificate should remain in force and the Survey has been completed to my satisfaction.

Signature of Surveyor ..... Place ..... Date .....

I have surveyed this ship for the purpose of seeing whether this Certificate should remain in force and the Survey has been completed to my satisfaction.

Signature of Surveyor ..... Place ..... Date .....

#### NOTES

1. This Certificate must be kept framed and posted up in some conspicuous part of the ship so long as it remains in force, and the ship is in use.
2. The Winter North Atlantic load line applies for voyages across the North Atlantic, North of latitude 36° N., during the winter months as defined in the Load Line Rules. The upper edge of the line through the centre of the disc applies for all other voyages.
3. This Certificate will be cancelled by the Minister if—
  - (a) material alterations have taken place in the hull or superstructures of the ship which affect the position of the load lines ; or
  - (b) the fittings and appliances for the protection of openings, the guard rails, the freeing ports or the means of access to the crew's quarters have not been maintained on the ship in as effective a condition as they were when the Certificate was issued ; or
  - (c) the periodical survey was not made as required by the Load Line Rules.
4. Where this Certificate has expired or been cancelled, it must be delivered up to the Assigning Authority and the ship may be detained until such requirement has been complied with, and if any owner or master fails without reasonable cause to comply with such requirement, he shall for each offence be liable to a fine not exceeding one hundred pounds.

I have surveyed this ship for the purpose of seeing whether this Certificate should remain in force and the Survey has been completed to my satisfaction.

Signature of Surveyor ..... Place ..... Date.....

---

I have surveyed this ship for the purpose of seeing whether this Certificate should remain in force and the Survey has been completed to my satisfaction.

Signature of Surveyor ..... Place ..... Date.....

---

I have surveyed this ship for the purpose of seeing whether this Certificate should remain in force and the Survey has been completed to my satisfaction.

Signature of Surveyor ..... Place ..... Date.....

---

I have surveyed this ship for the purpose of seeing whether this Certificate should remain in force and the Survey has been completed to my satisfaction.

Signature of Surveyor ..... Place ..... Date.....

---

#### NOTES

1. This Certificate must be kept framed and posted up in some conspicuous part of the ship so long as it remains in force, and the ship is in use.
2. The Winter North Atlantic load lines apply for voyages across the North Atlantic, North of Latitude 36°N, during the winter months as defined in the Load Line Rules. The periods during which the other seasonal load lines apply in different parts of the world are as stated in the Load Line Rules.
3. This Certificate may be cancelled by the Minister if—
  - (a) material alterations have taken place in the hull or superstructures of the ship which affect the position of the load lines ; or
  - (b) the fittings and appliances for the protection of openings, the guard rails, the freeing ports or the means of access to the crew's quarters have not been maintained on the ship in as effective a condition as they were in when the Certificate was issued ; or
  - (c) the periodical survey is not made as required by the Load Line Rules.
4. Where this Certificate has expired or been cancelled, it must be delivered up to the Assigning Authority and the ship may be detained until such requirement has been complied with, and if any owner or master fails without reasonable cause to comply with such requirement, he shall for each offence be liable to a fine not exceeding one hundred pounds.

*Appliances for closing access openings in bulkheads at ends of detached superstructures*

B 425

Forecastle .. .. .	
Bridge Fore End .. .. .	
Bridge After End .. .. .	
Raised Quarter Deck .. .. .	
Poop .. .. .	
<i>Temporary appliances for closing openings in superstructure decks</i>	

**Form M. of T.—LL.3**

**NIGERIAN LOAD LINE CERTIFICATE**

Issued under the authority of the Minister of Transport

Ship's Name ..... Official Number .....

Port of Registry .....

Gross Tonnage .....

*Freeboard from Deck Line*  
 Tropical            feet    inches (T)  
 Summer            feet    inches (S)

*Load Line*  
 inches above S  
 Upper edge of line  
 through centre of disc.  
 inches below S.  
 inches below S.  
 inches.

Winter            feet    inches (W)  
 Winter North Atlantic    feet    inches (WNA)  
 Allowance for fresh water for all freeboards  
 The upper edge of the deck line from which these freeboards are measured  
 is ..... inches above the top of the ..... deck at side.

This is to certify that this ship has been surveyed and the freeboards and load lines shown above have been assigned in accordance with the Merchant Shipping Act, (Nigeria) 1962.

This Certificate remains in force until .....  
 Issued at ..... on the ..... day of ..... 19 .....

*Signature and Description*

*Note.*—Where sea-going steamers navigate a river or inland water, deeper loading is permitted corresponding to the weight of fuel etc., required for consumption between the point of departure and the open sea.

NOTES

1. This Certificate must be kept framed and posted up in some conspicuous part of the ship so long as it remains in force, and the ship is in use.

2. The Winter North Atlantic load line applies for voyages across the North Atlantic, North of Latitude 36° N., during the winter months as defined in the Load Line Rules. The periods during which the other seasonal load lines apply in different parts of the world are as stated in the Load Line Rules.

3. This Certificate will be cancelled by the Minister if,

(a) material alterations have taken place in the hull or superstructures of the ship which affect the position of the load lines ; or

(b) the fittings and appliances for the protection of openings, the guard rails, the freeing ports or the means of access to the crew's quarters have not been maintained on the ship in as effective a condition as they were when the Certificate was issued ; or

(c) the periodical survey is not made as required by the Load Line Rules.

4. Where this Certificate has expired or been cancelled, it must be delivered up to the Assigning Authority and the ship may be detained until such requirement has been complied with, and if any owner or master fails without reasonable cause to comply with such requirement, he shall for each offence be liable to a fine not exceeding one hundred pounds.

I have surveyed this ship for the purpose of seeing whether this Certificate should remain in force and the Survey has been completed to my satisfaction.

Signature of Surveyor ..... Place ..... Date .....

I have surveyed this ship for the purpose of seeing whether this Certificate should remain in force and the Survey has been completed to my satisfaction.

Signature of Surveyor ..... Place ..... Date .....

I have surveyed this ship for the purpose of seeing whether this Certificate should remain in force and the Survey has been completed to my satisfaction.

Signature of Surveyor ..... Place ..... Date .....

I have surveyed this ship for the purpose of seeing whether this Certificate should remain in force and the Survey has been completed to my satisfaction.

Signature of Surveyor ..... Place ..... Date .....

The Survey of this ship for the renewal of the Load Line Certificate having been satisfactorily completed in accordance with the Load Line Rules, this Certificate is renewed until,

Place .....

Date ..... 19.....

*Signature and description*

I have surveyed this ship for the purpose of seeing whether this Certificate should remain in force and the Survey has been completed to my satisfaction.

Signature of Surveyor ..... Place ..... Date .....

I have surveyed this ship for the purpose of seeing whether this Certificate should remain in force and the Survey has been completed to my satisfaction.

Signature of Surveyor ..... Place ..... Date .....

I have surveyed this ship for the purpose of seeing whether this Certificate should remain in force and the Survey has been completed to my satisfaction.

Signature of Surveyor ..... Place ..... Date .....

I have surveyed this ship for the purpose of seeing whether this Certificate should remain in force and the Survey has been completed to my satisfaction.

Signature of Surveyor ..... Place ..... Date .....

*Appliances for closing access openings in bulkheads at ends of detached superstructures*

Forecastle .. .. .	.....
Bridge Fore End .. .. .	.....
Bridge After End .. .. .	.....
Raised Quarter Deck .. .. .	.....
Poop .. .. .	.....
	.....
	.....

Temporary appliances for closing openings in superstructure decks.

.....

.....

.....

NIGERIAN LOAD LINE CERTIFICATE  
Issued under the authority of the Minister of Transport

		Official Number
Ship's Name		
Port of Registry		
Registered Tonnage		
	<i>Freeboard from Deck Line</i>	<i>Load Line</i>
Tropical Summer } Winter }	feet      inches	Upper edge of line through centre of disc.
Winter North Atlantic } Atlantic }	feet   inches (WNA)	inches below upper edge of line through centre of disc.
Allowance for fresh water for all freeboards :—		inches.
The upper edge of the deck line from which these freeboards are measured is		inches above the top of the deck at side.

This is to certify that this ship has been surveyed and the freeboards and load lines shown above have been assigned in accordance with the Merchant Shipping Act, (Nigeria) 1962.

This Certificate remains in force until

Issued at                      on the                      day of                      19

*Signature and description*

*NOTE.*—Where sea-going steamers navigate a river or inland water, deeper loading is permitted corresponding to the weight of fuel, etc., required for consumption between the point of departure and the open sea.

NOTES

1. This Certificate must be kept framed and posted up in some conspicuous part of the ship so long as it remains in force, and the ship is in use.
2. The Winter North Atlantic load line applies for voyages across the North Atlantic, North of Latitude 36° N., during the winter months as defined in the Load Line Rules. The upper edge of the line through the centre of the disc applies for all other voyages.
3. This Certificate will be cancelled by the Minister if—
  - (a) material alterations have taken place in the hull or superstructures of the ship which affect the position of the load lines ; or
  - (b) the fittings and appliances for the protection of openings, the guard rails, the freeing ports or the means of access to the crew's quarters have not been maintained in as effective a condition as they were in when the Certificate was issued ; or
  - (c) the periodical survey is not made as required by the Load Line Rules.

4. Where this Certificate has expired or been cancelled, it must be delivered up to the Assigning Authority and the ship may be detained until such requirement has been complied with, and if any owner or master fails without reasonable cause to comply with such requirement, he shall for each offence be liable to a fine not exceeding one hundred pounds.

---

I have surveyed this ship for the purpose of seeing whether this Certificate should remain in force and the Survey has been completed to my satisfaction.

*Signature of Surveyor*

*Place*

*Date*

---

I have surveyed this ship for the purpose of seeing whether this Certificate should remain in force and the Survey has been completed to my satisfaction.

*Signature of Surveyor*

*Place*

*Date*

---

I have surveyed this ship for the purpose of seeing whether this Certificate should remain in force and the Survey has been completed to my satisfaction.

*Signature of Surveyor*

*Place*

*Date*

---

I have surveyed this ship for the purpose of seeing whether this Certificate should remain in force and the Survey has been completed to my satisfaction.

*Signature of Surveyor*

*Place*

*Date*

---

The Survey of this ship for the renewal of the Load Line Certificate having been satisfactorily completed in accordance with the Load Line Rules, this Certificate is renewed until

Place

Date

19

*Signature and description*

---

I have surveyed this ship for the purpose of seeing whether this Certificate should remain in force and the Survey has been completed to my satisfaction.

*Signature of Surveyor*

*Place*

*Date*

---

I have surveyed this ship for the purpose of seeing whether this Certificate should remain in force and the Survey has been completed to my satisfaction.

*Signature of Surveyor*

*Place*

*Date*

---

I have surveyed this ship for the purpose of seeing whether this Certificate should remain in force and the Survey has been completed to my satisfaction.

*Signature of Surveyor*

*Place*

*Date*

I have surveyed this ship for the purpose of seeing whether this Certificate should remain in force and the Survey has been completed to my satisfaction.

Signature of Surveyor

Place

Date

Appliances for closing access openings in bulkheads at ends of detached superstructures				
Forecastle	..	..	..	..
Bridge Fore End	..	..	..	..
Bridge After End	..	..	..	..
Raised Quarter Deck	..	..	..	..
Poop	..	..	..	..
Temporary appliances for closing openings in superstructures decks.				

(Rules 112 to 115)

### THIRD SCHEDULE

#### ZONES AND SEASONAL AREAS

#### FIRST PART

#### Summer and Tropical Zones

1. The Summer Zone shall consist of the two following areas —

(i) the area bounded (a) on the north by a line drawn from the east coast of North America along the parallel of  $36^{\circ}$  N. to Tarifa in Spain; from the east coast of Korea along the parallel of  $35^{\circ}$  N. to the west coast of Honshiu, Japan; from the east coast of Honshiu along the parallel of  $35^{\circ}$  N. to long.  $150^{\circ}$  W., and thence along a rhumb line to the west coast of British Columbia at lat.  $55^{\circ}$  N., and (b) on the south by a line drawn from Cape Catoche in the Yucatan to Cape San Antonio in Cuba; along the south Cuban coast to lat.  $20^{\circ}$  N., and along the parallel of  $20^{\circ}$  N. to the west coast of Africa; from the port of Hong Kong along a rhumb

line to the port of Sual (Luzon Island), and along the west coast of the Islands of Luzon, Samar and Leyte to the parallel of  $10^{\circ}$  N. thence along the parallel of  $10^{\circ}$  N. to long.  $145^{\circ}$  E. thence north to latitude  $13^{\circ}$  N. and thence along the parallel of  $13^{\circ}$  N. to long.  $160^{\circ}$  E. thence along the meridian of  $160^{\circ}$  E. to lat.  $25^{\circ}$  N. thence along the parallel of  $25^{\circ}$  N. to long.  $130^{\circ}$  W. thence south along the meridian of  $130^{\circ}$  W. to lat.  $13^{\circ}$  N. thence along the parallel of  $13^{\circ}$  N. to long.  $105^{\circ}$  W. to lat.  $13^{\circ}$  rhumb line to the point lat.  $30^{\circ}$  N., long.  $120^{\circ}$  W. and from that point along the meridian to the Californian coast.

(ii) the area bounded (a) on the north by a line from the east coast of South America along the Tropic of Capricorn to the west coast of Africa; from the east coast of Africa along the parallel of  $20^{\circ}$  S. to the west coast of Madagascar, thence along the west and north coast of Madagascar to long.  $50^{\circ}$  E. thence north to lat.  $10^{\circ}$  S. thence along the parallel of  $10^{\circ}$  S. to long.  $110^{\circ}$  E. thence along a rhumb line to Port Darwin, Australia, thence along the north and north-east coast of Australia to lat.  $20^{\circ}$  S. thence along the parallel of  $20^{\circ}$  S. to long.  $175^{\circ}$  E. thence along the meridian of  $175^{\circ}$  E. to lat.  $11^{\circ}$  S. thence along the parallel of  $11^{\circ}$  S. to long.  $150^{\circ}$  W. thence south along the meridian of  $150^{\circ}$  W. to lat.  $20^{\circ}$  S. thence along the parallel of  $20^{\circ}$  S. to a point where that parallel meets the rhumb line drawn from lat.  $11^{\circ}$  S. long.  $150^{\circ}$  W. to lat.  $26^{\circ}$  S. long.  $75^{\circ}$  W. thence along that rhumb line to the latter point and thence along the rhumb line to the west coast of South America at lat.  $30^{\circ}$  S.; and (b) on the south by a line drawn from the east coast of South America along the parallel of  $40^{\circ}$  S. to long.  $56^{\circ}$  W. thence along a rhumb line to the point lat.  $34^{\circ}$  S. long.  $50^{\circ}$  W. thence along the parallel of  $34^{\circ}$  S. to the west coast of South Africa; from the east coast of South Africa at lat.  $30^{\circ}$  S. along a rhumb line to the point lat.  $35^{\circ} 30'$  S. long.  $118^{\circ}$  E., off the South coast of Australia thence along a rhumb line to Cape Grim, Tasmania, thence along the north coast of Tasmania to Eddystone Point thence along a rhumb line to the west coast of South Island, New Zealand, at long.  $170^{\circ}$  E. thence along the west, south and east coasts of South Island to Cape Saunders thence along a rhumb line to the point lat.  $33^{\circ}$  S. long.  $170^{\circ}$  W. and thence along the parallel of  $33^{\circ}$  S. to the west coast of South America.

## 2. The Tropical Zone shall consist of—

(i) the area being bounded (a) on the north by a line drawn from the east coast of South America at lat.  $10^{\circ}$  N. along the parallel of  $10^{\circ}$  N. to long.  $20^{\circ}$  W. thence north along the meridian to lat.  $20^{\circ}$  N. and thence along the parallel of  $20^{\circ}$  N. to the west coast of Africa; from the east coast of Africa at lat.  $8^{\circ}$  N. along the parallel to the west coast of the Malay Peninsula, following thence the coast of Malaya and Siam to the east of Cochin China at lat.  $10^{\circ}$  N. thence along the parallel of  $10^{\circ}$  N. to long.  $145^{\circ}$  E. thence north along the meridian to lat.  $13^{\circ}$  N. and thence along the parallel of  $13^{\circ}$  N. to the west coast of central America; and (b) on the south by a line drawn from the east coast of South America along the Tropic of Capricorn to the west coast of Africa; from the east coast of Africa along the parallel of  $20^{\circ}$  S. to the west coast of Madagascar thence along the west and north coasts of Madagascar to long.  $50^{\circ}$  E. thence north to lat.  $10^{\circ}$  S. thence along the parallel of  $10^{\circ}$  S. to long.  $110^{\circ}$  E. thence along a rhumb line to Port Darwin, Australia, thence eastwards along the coast of Australia and Wessel Island to Cape Wessel, thence along the parallel of  $11^{\circ}$  S. to the west side of Cape York; from the east side of Cape York at lat.  $11^{\circ}$  S. along the parallel of  $11^{\circ}$  S. to long.  $150^{\circ}$  W. thence along a rhumb line to the point lat.  $26^{\circ}$  S. long.  $75^{\circ}$  W. and thence along a rhumb line to the West coast of South America at Lat.  $30^{\circ}$  S.

- (ii) The Suez Canal, the Red Sea and the Gulf of Aden to the westward of the meridian of  $45^{\circ}$  E. and
- (iii) The Persian Gulf to the westward of the meridian of  $59^{\circ}$  E.
- NOTES.—(i) The following ports are to be treated as being on the boundary between the Summer Zone and the Tropical Zone :—Coquimbó, Port Darwin and Rio de Janeiro.
- (ii) The port of Fusan (Korea) is to be treated as being on the boundary between the Summer Zone and the area numbered 4 in the Second Part of this Schedule.
- (iii) The port of Yokohama is to be treated as being on the boundary between the Summer Zone and the area numbered 5 in the Second Part of this Schedule.
- (iv) The following ports are to be treated as being on the boundary between the Summer Zone and the area numbered 6 in the Second Part of this Schedule :—Cape Town, Durban, and Valparaiso.
- (v) The following ports are to be treated as being on the boundary between the Summer Zone and the area numbered 11 in the Third Part of this Schedule :—Hong Kong and Suai.
- (vi) The following ports are to be treated as being on the boundary between the Tropical Zone and the area numbered 9 in the Third Part of this Schedule :—Aden and Berbera.
- (vii) Saigon is to be treated as being on the boundary between the Tropical Zone and the area numbered 11 in the Third Part of this Schedule.
- (viii) Mackay is to be treated as being on the boundary between the Summer Zone and the area numbered 14 in the Third Part of this Schedule.

THIRD SCHEDULE  
SECOND PART  
Seasonal Areas—Summer and Winter

No.	Area	Summer Period	Winter Period
	Description		
1.	The area within and to the northwards of the following line :— A line drawn south from the coast of Greenland at long. $50^{\circ}$ W to lat. $45^{\circ}$ N thence along the parallel of $45^{\circ}$ N to long. $15^{\circ}$ W thence north to lat. $60^{\circ}$ N thence along the parallel of $60^{\circ}$ N to the west coast of Norway. Bergen is considered as being on the boundary between this area and area 2 below.	16th April to 15th October.	16th October to 15th April.

THIRD SCHEDULE

SECOND PART

Seasonal Areas—Summer and Winter

<i>Area</i>		<i>Summer Period</i>	<i>Winter Period</i>
<i>No.</i>	<i>Description</i>		
2.	The area north of a line drawn from the east coast of America along the parallel of 36° N to Tarifa in Spain excluding area 1 above but including the Baltic Sea.	1st April to 31st October.	1st November to 31st March.
3.	The Mediterranean and the Black Seas.	16th March to 15th December.	16th December to 15th March.
4.	The Sea of Japan between the parallels of 35° N and 50° N	1st March to 30th November.	1st December to 28/29th February.
5.	The area north of a line drawn from the east coast of Honshiu in Japan along the parallel of 35° N to long. 150° W and thence along a rhumb line to the west coast of British Columbia at lat. 55° N, but excluding area 4 above.	16th April to 15th October.	16th October to 15th April.
6.	The area south of a line drawn from the east coast of South America along the parallel of 40° S to long. 56° W thence along a rhumb line to the point lat. 34° S. long. 50° W. thence along the parallel of 34° S to the west coast of South Africa ; from the east coast of South Africa at lat. 30° S. along a rhumb line to the point lat. 35° 30' S long. 118° E off the south coast of Australia thence along a rhumb line to Cape Grim, Tasmania thence along the north coast of Tasmania to Eddystone Point thence along a rhumb line to the west coast of South Island New Zealand, at long. 170° E thence along the west south and east coasts of South Island to Cape Saunders thence along a rhumb line to the point in lat. 33° S long. 170° W ; and thence along the parallel of 33° S to the west coast of South America.	16th October to 15th April.	16th April to 15th October.

## THIRD SCHEDULE

## SECOND PART

## Seasonal Areas—Summer and Winter

No.	Area Description	Summer Period	Tropical Period
7.	The area bounded on the north by a line from Cape Catoche in Yucatan to Cape San Antonio in Cuba, along the south Cuban coast to lat. 20° N and along the parallel of 20° N to the point lat. 20° N long. 20° W; on the west by the coast of Central America; on the south by the north coast of South America and by the parallel of 10° N; and on the east by the meridian of 20° W.	16th July to 31st October.	1st November to 15th July.
	The area of the Arabian Sea north of the parallel of 24° N and east of the meridian of 59° E.	21st May to 31st July.	1st August to 20th May.
	Karachi is considered as being on the boundary between this area and area 9 below.	21st May to 15th September & 16th October to 30 November.	1st December to 20th May and 16th September to 15th October.
9.	The area of the Arabian Sea south of the parallel of 24° N, north of the parallel of 8° N and east of the meridian of 45° E.	21st May to 15th September & 16th October to 30 November.	1st December to 20th May and 16th September to 15th October.
10.	The area of the Bay of Bengal north of the parallel of lat. 8° N.	16th April to 15th December.	16th December to 15th April.
11.	The area of the China Sea, bounded on the west and north by the coast of Indo-China and China to Hong Kong; on the east by a rhumb line to the port of Sual (Luzon Island) and by the west coast of the Islands of Luzon, Samar and Leyte to the parallel of 10° N; and on the south by the parallel of 10° N.	1st May to 20th January.	21st January to 30th April.
12.	The area in the North Pacific Ocean bounded on the north by the parallel of 25° N, on the west by the meridian of 160° E; on the south by the parallel of 13° N; and on the east by the meridian of 130° W.	1st November to 31st March.	1st April to 31st October.

THIRD SCHEDULE

SECOND PART

Seasonal Areas—Summer and Winter

<i>Area</i>		<i>Summer Period</i>	<i>Tropical Period</i>
<i>No.</i>	<i>Description</i>		
13.	The area bounded on the north and east by the coast of California, Mexico and Central America ; on the west by the meridian of 120° W and by a rhumb line from the point lat. 30° N long. 120° W., to the point lat. 13° N long. 105° W ; and on the south by the parallel of 13° N.	1st July to 31st October & 1st December to 28/29th February.	1st March to 30th June and 1st to 30th November.
14.	The area in the South Pacific Ocean bounded on the north by the parallel of 11° S. ; on the west by the east coast of Australia ; on the south by the parallel of 20° S, and on the east by the meridian of 175° E, together with the Gulf of Carpentaria south of the parallel of 11° S.	1st December to 31st March.	1st April to 30th November.
15.	The area bounded on the west by the meridian of 150° W ; on the south by the parallel of 20° S ; and on the north and east by a rhumb line drawn from the point lat. 11° S long. 150° W to the point lat. 26° S long. 75° W.	1st December to 28th/29th February.	1st March to 30th November.

TABLE 1

(Coamings 24 inches in Height)

HATCHWAY BEAMS AND FORE-AND-AFTERS FOR SHIPS 200 FEET OR MORE IN LENGTH\*

## HATCHWAY BEAMS

Breadth of Hatchway	Mounting		Beams with Fore-and-Afters						Beams without Fore-and-Afters			
			Spacing Centre to Centre						Spacing Centre to Centre			
			6' 0"	8' 0"	10' 0"	10' 0"	4' 0"	5' 0"				
10' 0"	ins. 3	ins. .40A	ins. 11	ins. .30P	ins. 12	ins. .32P	ins. 14	ins. .34P	ins. 9	ins. .46BP	ins. 10	ins. .50BP
12' 0"	3	x	12	x	x	x	x	x	11	x	x	x
14' 0"	3	x	14	x	x	x	x	x	17	x	x	x
16' 0"	3	x	16	x	x	x	x	x	17	x	x	x
18' 0"	3 $\frac{1}{2}$	x	18	x	x	x	x	x	19	x	x	x
20' 0"	4	x	20	x	x	x	x	x	21	x	x	x
22' 0"	4 $\frac{1}{2}$	x	22	x	x	x	x	x	21	x	x	x
24' 0"	5	x	24	x	x	x	x	x	22	x	x	x
26' 0"	5 $\frac{1}{2}$	x	26	x	x	x	x	x	22	x	x	x
28' 0"	6	x	28	x	x	x	x	x	24	x	x	x
30' 0"	6	x	30	x	x	x	x	x	26	x	x	x

FORE-AND-AFTERS

Length of Fore-and-Afters	Mounting		Bulb Plate Centre Fore-and-Afters						Bulb Angle Side Fore-and-Afters					
			Spacing Centre to Centre			Spacing Centre to Centre			Spacing Centre to Centre			Spacing Centre to Centre		
	ins.	ins.	3' 0"	4' 0"	5' 0"	3' 0"	4' 0"	5' 0"	3' 0"	4' 0"	5' 0"	3' 0"	4' 0"	5' 0"
6' 0"	2 1/2 x 2 1/2	ins. x .36	6 x 6	6 1/2 x 6 1/2	7 x 7	ins. x .38	6 x 6	6 x 3	ins. x .36	6 1/2 x 6 1/2	7 x 3 1/2	ins. x .38	7 x 7	ins. x .38
8' 0"	2 1/2 x 2 1/2	ins. x .38	7 x 7	8 x 8	9 x 9	ins. x .42	8 x 8	8 x 3 1/2	ins. x .42	8 x 8	9 x 3 1/2	ins. x .44	9 x 9	ins. x .44
10' 0"	2 1/2 x 2 1/2	ins. x .40	8 x 8	9 1/2 x 9 1/2	11 x 11	ins. x .50	8 x 8	8 x 3 1/2	ins. x .50	9 1/2 x 9 1/2	11 x 3 1/2	ins. x .50	11 x 11	ins. x .50

Wood Centre Fore-and-Afters		Wood Side Fore-and-Afters					
		Spacing Centre to Centre			Spacing Centre to Centre		
3' 0"	4' 0"	5' 0"	3' 0"	4' 0"	5' 0"	3' 0"	4' 0"
D	B	D	D	B	D	D	B
ins. 5 1/2	ins. 7	ins. 6 1/2	ins. 6	ins. 7	ins. 5 1/2	ins. 5 1/2	ins. 6
ins. 6 1/2	ins. 7 1/2	ins. 8	ins. 7 1/2	ins. 8 1/2	ins. 6 1/2	ins. 6 1/2	ins. 7
ins. 8	ins. 8	ins. 9	ins. 8	ins. 9	ins. 7	ins. 8	ins. 8

A = Plain angle.  
 BP = Bulb Plate.  
 P = Plate.  
 D = Depth.  
 B = Breadth.

Depths for hatchway beams are at the middle of the length and are measured from the top mounting to the lower edge. Depths for fore-and-afters are measured from the under side of the hatch covers to the lower edge. Sizes for intermediate lengths and spacing are obtained by interpolation. Where plates are specified, two angles, of the size given for mountings, are to be fitted at the upper and at the lower part of the beam. Where bulb plates are specified, two angles, of the size given for mountings, are to be fitted at the upper part of the beam or fore-and-after. Where bulb angles are specified, one angle, of the size given for mountings, is to be fitted at the upper part of the section. Where the specified flanges of an angle are of different dimensions, the larger flange is to be horizontal.

\*In ships not exceeding 100 feet in length, the depths of beams which are formed of plates and angles may be 60 per cent of the depths given above; the depths of beams and steel fore-and-afters formed of bulb angle or bulb plate section may be 80 per cent of the depths given above; the thickness of plates, bulb angles and bulb plates should correspond to the thickness tabulated for the reduced depths with a minimum thickness of .30 inch; the depths and breadths of wood fore-and-afters may be 80 per cent of those given in the tables for side fore-and-afters, but the centre fore-and-afters must be not less than 6 1/2 inches wide. In ships between 100 feet and 200 feet in length, the sizes of the beams and fore-and-afters are to be determined by linear interpolation.

TABLE 2  
 (Coatings 18 inches in Height)  
 HATCHWAY BEAMS AND FORE-AND-AFTERS FOR SHIPS 200 FEET OR MORE IN LENGTH\*  
 HATCHWAY BEAMS

Breadth of Hatchway	Mounting		Beams with Fore-and-Afters				Beams without Fore-and-Afters					
			Spacing Centre to Centre				Spacing Centre to Centre					
			6' 0"	8' 0"	10' 0"	10' 0"	4' 0"	5' 0"	4' 0"	5' 0"		
10' 0"	ins. 3	ins. 3	ins. .40A	ins. .46BP	ins. 10½	ins. .50BP	ins. 14½	ins. .52BP	ins. 8	ins. .40BP	ins. 8	ins. .44BP
12' 0"	3	3	.40A	.50BP	11	.30P	13	.34P	9	.44BP	9	.50BP
14' 0"	3	3	.42A	.30P	13	.32P	15	.34P	10	.50BP	10	.30P
16' 0"	3½	3	.42A	.32P	15	.34P	17	.36P	11	.30P	11	.32P
18' 0"	4	3	.44A	.34P	17	.36P	19	.38P	12	.32P	12	.34P
20' 0"	4	3	.44A	.36P	19	.38P	21	.40P	12½	.37P	13	.34P
22' 0"	4½	3	.46A	.36P	20	.38P	23	.40P	13	.34P	14	.34P
24' 0"	5	3½	.46A	.38P	21	.38P	25	.42P	13½	.34P	14½	.34P
26' 0"	5½	3½	.48A	.38P	22	.38P	26	.42P	14	.34P	15	.34P
28' 0"	6	3½	.50A	.38P	23	.40P	27	.42P	14½	.34P	16	.34P
30' 0"	6	3½	.52A	.38P	24	.40P	28	.42P	15	.34P	17	.36P

FORE-AND-AFTERS

Length of Fore-and-Afters	Mounting		Bulb Plate Centre Fore-and-Afters				Bulb Angle Side Fore-and-Afters				
			Spacing Centre to Centre				Spacing Centre to Centre				
	ins.	ins.	3' 0"	4' 0"	5' 0"	3' 0"	4' 0"	5' 0"	3' 0"	4' 0"	5' 0"
6' 0"	2½ × 2½	ins. 36	5 × 3.4	5½ × 3.4	6 × 3.6	5 × 3 × .34	5½ × 3 × .34	6 × 3 × .36	ins. 6 × 3 × .36	ins. 7½ × 3½ × .42	ins. 9 × 3½ × .50
8' 0"	2½ × 2½	ins. 38	6 × 3.8	7 × .40	7½ × .42	6 × 3 × .38	7 × 3 × .40	7½ × 3½ × .42	ins. 7½ × 3½ × .42	ins. 8 × 3½ × .46	ins. 9 × 3½ × .50
10' 0"	2½ × 2½	ins. 40	7 × 4.4	8 × .46	9 × .50	7 × 3 × .44	8 × 3½ × .46	9 × 3½ × .50	ins. 8 × 3½ × .46	ins. 9 × 3½ × .50	ins. 9 × 3½ × .50

Wood Centre Fore-and-Afters

Length of Fore-and-Afters	Mounting		Bulb Plate Centre Fore-and-Afters				Bulb Angle Side Fore-and-Afters				
			Spacing Centre to Centre				Spacing Centre to Centre				
	ins.	ins.	3' 0"	4' 0"	5' 0"	3' 0"	4' 0"	5' 0"	3' 0"	4' 0"	5' 0"
6' 0"	5	ins. 7	5 × 6½	6 × 7	7 × 7	5 × 5	5½ × 5½	6 × 6	ins. 5 × 5	ins. 6 × 6	ins. 7 × 7
8' 0"	6	ins. 7	6 × 7½	7 × 8	8 × 8	6 × 6	7 × 7	8 × 8	ins. 6 × 6	ins. 7 × 7	ins. 8 × 8
10' 0"	7	ins. 7	7 × 7½	8 × 8	9 × 9	7 × 7	8 × 8	9 × 9	ins. 7 × 7	ins. 8 × 8	ins. 9 × 9

Wood Side Fore-and-Afters

Length of Fore-and-Afters	Mounting		Bulb Plate Centre Fore-and-Afters				Bulb Angle Side Fore-and-Afters				
			Spacing Centre to Centre				Spacing Centre to Centre				
	ins.	ins.	3' 0"	4' 0"	5' 0"	3' 0"	4' 0"	5' 0"	3' 0"	4' 0"	5' 0"
6' 0"	5	ins. 7	5 × 6½	6 × 7	7 × 7	5 × 5	5½ × 5½	6 × 6	ins. 5 × 5	ins. 6 × 6	ins. 7 × 7
8' 0"	6	ins. 7	6 × 7½	7 × 8	8 × 8	6 × 6	7 × 7	8 × 8	ins. 6 × 6	ins. 7 × 7	ins. 8 × 8
10' 0"	7	ins. 7	7 × 7½	8 × 8	9 × 9	7 × 7	8 × 8	9 × 9	ins. 7 × 7	ins. 8 × 8	ins. 9 × 9

A = Plain Angle

BP = Bulb Plate

P = Plate

D = Depth

B = Breadth.

Depths for hatchway beams are at the middle of the length and are measured from the top mounting to the lower edge. Depths for fore-and-afters are measured from the under side of the hatch covers to the lower edge. Sizes for intermediate length and spacing are obtained by interpolation. Where plates are specified, two angles, of the size given for mountings, are to be fitted at the upper and the lower part of the beam. Where bulb plates are specified, two angles, of the size given for mountings, are to be fitted to the upper part of the beam or fore-and-after. Where bulb angles are specified, one angle, of the size given for mountings, is to be fitted at the upper part of the section. Where the specified flanges of an angle are of different dimensions, the larger flange is to be horizontal.

• In ships not exceeding 100 feet in length, the depths of beams which are formed of plates and angles may be 60 per cent of the depths given above; the depths of beams and steel fore-and-afters formed of bulb angle or bulb plate section may be 80 per cent of the depths given above; the thickness of plates, bulb angles and bulb plates should correspond to the thickness tabulated for the reduced depths with a minimum thickness of .30 inch; the depths and breadths of wood fore-and-afters may be 80 per cent of those given in the tables for side fore-and-afters, but the centre fore-and-afters must be not less than 6½ inches wide. In ships between 100 feet and 200 feet in length, the sizes of the beams and fore-and-afters are to be determined by linear interpolation.

Bridge Front Bulkheads, Unprotected Bulkheads or Poops A L or More in length.		Bulkheads of Poops Partially Protected, or Lets in Length than A L	
Length of Ship	Bulb Angle Stiffeners	Length of Ship	Plain Angle Stiffeners
Feet Under 160	Inches 5½ x 3 x .30	Feet Under 150	Inches 3 x 2½ x .30
160	6 x 3 x .32	150	3½ x 2½ x .32
200	6½ x 3 x .34	200	4 x 3 x .34
240	7 x 3 x .36	250	4½ x 3 x .36
280	7½ x 3 x .38	300	5 x 3 x .38
320	8 x 3 x .40	350	5½ x 3 x .42
360	8½ x 3 x .42		6 x 3 x .44
400	9 x 3 x .44		6½ x 3½ x .46
440	9½ x 3½ x .46		7 x 3½ x .48
480	10 x 3½ x .48		7 x 3½ x .50
520	10½ x 3½ x .50		7 x 3½ x .52
560	11 x 3½ x .52		
	Bulkhead Plating		Bulkhead Plating
200 and under	Inch .3	160 and under	Inch .24
360 and above	.44	400 and above	.38
	Bulkhead Plating		Bulkhead Plating
			Inch .20
			.30

For ships intermediate in length the thicknesses of bulkhead plating are obtained by interpolation.

MADE at Lagos the 17th day of September, 1964,

R. A. Njoku,  
Minister of Transport

EXPLANATORY NOTE

These Rules lay down the maximum depths to which vessels may be loaded in varying circumstances and include such requirements as appear to the Minister to be necessary to implement the provisions of the International Convention Respecting Load Lines, 1930.

MERCHANT SHIPPING ACT, 1962  
1962, No. 30

Merchant Shipping Act (Delegation of Powers)  
(Amendment) Notice, 1964

Commencement : 17th September, 1964

In exercise of the powers conferred by section 414 of the Merchant Shipping Act, 1962, and of all other powers enabling me in that behalf I hereby give the following notice—

1. This Notice may be cited as the Merchant Shipping Act (Delegation of Powers) (Amendment) Notice, 1964.

Citation.

2. The Schedule to the Merchant Shipping Act (Delegation of Powers) Notice 1963 is hereby amended by the insertion, immediately after paragraph 93, of the following new paragraphs :—

Amendment of L.N. 112 of 1963.

“94. To give consent in writing on such terms and conditions as may be necessary Section 331

Government Inspector of Shipping

95. To give consent in writing on such terms and conditions as may be necessary Section 345(3)

Government Inspector of Shipping”

MADE in Lagos this 17th day of September, 1964.

R. A. NJOKU,  
Minister of Transport



The following Bills, which will in due course be presented to Parliament for enactment, are published for general information.

EXPORT OF NIGERIAN PRODUCE (MID-WESTERN NIGERIA APPLICATION) BILL

EXPLANATORY MEMORANDUM

The object of this Bill is to remove doubt as to the application of the Export of Nigerian Produce Act 1958 to Mid-Western Nigeria occasioned by the creation of that Region subsequent to the passing of such Act.

ZANNA BUKAR DIPCHARIMA,  
Minister of Commerce and Industry

A BILL

FOR

AN ACT TO AMEND THE EXPORT OF NIGERIAN PRODUCE ACT 1958, SO AS TO MAKE SPECIFIC PROVISION FOR MID-WESTERN NIGERIA

[ ]

WHEREAS the Export of Nigerian Produce Act, 1958 (hereafter in this Act referred to as "the principal Act") makes divers provisions in respect of regional marketing boards and of the application of the regional marketing laws :

Commencement.  
No. 36 of 1958.

5 AND WHEREAS doubts have arisen as to the extent of application of the principal Act to Mid-Western Nigeria and it is necessary that they be resolved :

10 BE IT THEREFORE ENACTED by the Legislature of the Federation of Nigeria in this present Parliament assembled and by the authority of the same as follows :

1. In section two of the principal Act (which provides sundry interpretations for use in the principal Act)—

Meaning of sundry expressions extended or explained.

15 (a) in the definition of "Regional Marketing Board" that definition shall be amended by inserting at the end thereof the words "or the Mid-Western Region Marketing Board" ; and

20 (b) the Western Region Marketing Law 1954 referred to in the expression "Regional Marketing Law" shall apply to Mid-Western Nigeria as effectively as it applies to Western Nigeria but subject to section two of the Mid-Western Nigeria (Transitional Provisions) Act, 1963 (which provides for the continuance only in certain circumstances of divers laws).

2.—(1) This Act may be cited as the Export of Nigerian Produce (Mid-Western Nigeria Application) Act, 1964 and this Act and the principal Act as heretofore amended may be cited together as the Export of Nigerian Produce Acts 1958 to 1964.

(2) This Act shall apply throughout the Federation.

(923)

# EVIDENCE (AMENDMENT) BILL

## EXPLANATORY MEMORANDUM

The power to sign conferred by the Evidence Act in respect of certain certificates for use as evidence in criminal cases is restricted to a few only of the Central Bank officials.

The object of this Bill is to empower other officers of that Bank to be authorised by the Governor thereof to the like effect.

F. S. OKOTIE-EBOH,  
*Minister of Finance*

## A BILL

FOR

AN ACT TO AMEND THE EVIDENCE ACT AS TO CERTAIN CERTIFICATES IN CRIMINAL CASES.

[ ]

BE IT ENACTED by the Legislature of the Federation of Nigeria in this present Parliament assembled and by the authority of the same as follows :—

Commence-  
ment.

1. —Where a certificate purports to be signed by an officer of the  
5 Central Bank of Nigeria who himself adds after his signature the words  
“duly authorised by the Governor of the Central Bank of Nigeria for the  
purposes of section forty-one of the Evidence Act” it shall be accepted  
by all courts and persons as sufficient evidence of the facts stated in the  
certificate, and no certificate shall be questioned on the ground only of  
10 the authorisation ; but subject thereto the proviso to subsection (1) of  
section forty-one of the Evidence Act shall have effect with regard to  
any such certificate.

Certificates  
of Central  
Bank officers  
as evidence  
in criminal  
cases.

Cap. 62.

2.—(1) This Act may be cited as the Evidence (Amendment) Act,  
1964 and shall be read as one with the Evidence Act.

Short title,  
repeal and  
operation.  
Cap. 62

15 (2) The Evidence (Amendment) Act, 1960 is hereby repealed.

(3) This Act shall apply throughout the Federation.

No. 14 of  
1960.



# THE CIVIL AVIATION BILL

## EXPLANATORY MEMORANDUM

It is desirable in its own interest that the Republic of Nigeria, realising the need to keep abreast of developments in the field of Aviation and as a member state of the International Civil Aviation Organisation should enact its own civil aviation law.

The main purpose of this bill is therefore to replace obsolete and redundant United Kingdom civil aviation law as applied to Nigeria mainly under the Colonial Aviation Orders mentioned in the Schedule to this Bill.

K. O. MBADIWE,  
*Federal Minister of Aviation*

### ARRANGEMENT OF CLAUSES

#### *Control of air navigation*

##### *Clause*

1. Power to regulate air navigation.
2. Investigation of accidents.
3. Dangerous flying.

#### *Control of air transport undertakings, etc.*

4. Licensing of air transport undertakings.
5. Duty to furnish information about air transport undertakings.

#### *Provision of airports and control of land for aviation purposes*

6. Power of Minister to provide airports, etc.
7. Control of land in the interests of aviation.
8. Indication of presence of obstructions near airports.

#### *Special provisions as to trespass, nuisance, salvage and patents, etc.*

9. Liability in respect of trespass, nuisance and surface damage from aircraft.
10. Liability in respect of nuisance at airports.
11. Application to aircraft of law of wreck and salvage.
12. Exemption of aircraft etc. from seizure on patent claims.

#### *General*

13. Offences.
14. Compensation.
15. Application of Act to the state.
16. Subsidiary legislation.
17. Interpretation, etc.
18. Repeals and transitional provisions.
19. Short title, extent and commencement.

SCHEDULE—Enactments repealed.



# A BILL

## FOR

AN ACT TO MAKE FRESH PROVISION AS RESPECTS CIVIL AVIATION ; AND FOR CONNECTED PURPOSES.

[See section 19(2)]

BE IT ENACTED by the Legislature of the Federation of Nigeria in this present Parliament assembled and by the authority of the same as follows :—

Commence-  
ment.

### *Control of air navigation*

5 1.—(1) The Minister may by regulations make such provision as appears to him to be necessary or expedient—

Power to  
regulate air  
navigation.

(a) for carrying out the Convention on International Civil Aviation concluded at Chicago on the seventh day of December, 1944, any annex to the convention which relates to international standards and recommended practices and is adopted in accordance with the convention, and any amendment of the convention or of any such annex which is made in accordance with the convention ;

(b) generally for regulating air navigation.

15 (2) Without prejudice to the generality of the foregoing subsection, the powers conferred by that subsection shall in particular include power to make regulations—

(a) as to the registration of aircraft in Nigeria ;

20 (b) for prohibiting aircraft from flying unless certificates of airworthiness issued or validated under the regulations are in force with respect to them and except upon compliance with such conditions as to maintenance and repair as may be prescribed ;

25 (c) for the licensing, inspection and regulation of airports, for access to airports and places where aircraft have landed, for the inspection of aircraft factories, and for prohibiting or regulating the use of airports which are not licensed in pursuance of the regulations ;

30 (d) for prohibiting persons from engaging in, or being employed in or in connection with, air navigation in such capacities as may be prescribed unless they satisfy the prescribed requirements, and for the licensing of persons employed at airports in the inspection, testing or supervision of aircraft ;

(e) as to the conditions under which, and in particular the airports to or from which, aircraft entering or leaving Nigeria may fly, and as to the conditions under which aircraft may fly from one part of Nigeria to another ;

35 (f) as to the conditions under which passengers and goods may be carried by air and under which aircraft may be used for other gainful purposes, and for prohibiting the carriage by air of goods of such classes as may be prescribed ;

- (g) for minimizing or preventing interference with the use or effectiveness of apparatus used in connection with air navigation, and for prohibiting or regulating the use of such apparatus and the display of signs and lights liable to endanger aircraft ; 5
- (h) generally for securing the safety, efficiency and regularity of air navigation and the safety of aircraft and of persons and property carried in aircraft, and for preventing aircraft from endangering other persons and property ; 5
- (i) for requiring persons engaged in, or employed in or in connection with, air navigation to supply meteorological information for the purposes of air navigation ; 10
- (j) for regulating the making of signals and other communications by or to aircraft and persons carried in aircraft ;
- (k) for instituting and regulating the use of a civil air ensign and any other ensign established by the Minister for purposes connected with air navigation ; 15
- (l) for prohibiting aircraft from flying over such areas in Nigeria as may be prescribed ;
- (m) for applying, with or without modifications, the enactments relating to customs in relation to airports and to aircraft and to persons and property carried in aircraft ; 20
- (n) as to the manner and conditions of the issue, validation, renewal, extension or variation of any certificate, licence or other document required by the regulations (including the examinations and tests to be undergone), and as to the form, custody, production, cancellation, suspension, endorsement and surrender of any such document ; 25
- (o) for the registration of births and deaths occurring in aircraft and of particulars of persons missing from aircraft ;
- (p) for regulating the charges that may be made for the use of airports licensed under the regulations and for services provided at such airports ; 30
- (q) for specifying the fees to be paid in respect of the issue, validation, renewal, extension or variation of any certificate, licence or other document or the undergoing of any examination or test required by virtue of the regulations and in respect of any other matters in respect of which it appears to the Minister to be expedient for the purposes of the regulations to charge fees ; 35
- (r) for exempting from the provisions of the regulations or any of them any aircraft or persons or classes of aircraft or persons.
- (3) Regulations under this section may provide for the imposition of penalties for offences against the regulations, not exceeding in the case of any particular offence a fine of five hundred pounds and imprisonment for a term of six months, and, subject to Chapter III of the Constitution of the Federation (which relates to fundamental rights), for the taking of such steps (including firing on aircraft) as may be prescribed in respect of aircraft flying over areas of Nigeria over which flying is prohibited by the regulations, 40 45

2.—(1) Without prejudice to the generality of subsection (1) of the foregoing section, the Minister may make regulations providing for the investigation of any accident arising out of or in the course of air navigation and either occurring in or over Nigeria or occurring to Nigerian aircraft elsewhere.

Investigation of accidents.

(2) Without prejudice to the generality of the foregoing subsection, regulations under this section may in particular contain provision—

(a) requiring notice to be given of any such accident as aforesaid in such manner and by such persons as may be prescribed ;

(b) applying, with or without modifications, for the purpose of investigations held with respect to any such accidents any of the provisions of any law in force in Nigeria relating to the investigation of deaths or accidents ;

(c) prohibiting, pending investigation, access to or interference with aircraft to which an accident has occurred and authorising any person, so far as may be necessary for the purposes of an investigation, to have access to, examine, remove, take measures for the preservation of, or otherwise deal with, any such aircraft ;

(d) authorising or requiring the cancellation, suspension, endorsement or surrender of any licence or certificate granted in Nigeria in pursuance of this Act or the withdrawal or suspension of any validation conferred in Nigeria of a licence granted by a competent authority elsewhere, where it appears on investigation that the licence, certificate or validation ought to be so dealt with, and requiring the production accordingly of any such licence or certificate.

3.—(1) Where an aircraft is flown in such a manner as to cause danger to any person or property on land or water, the pilot or other person in charge of the aircraft and the owner of the aircraft shall be liable on summary conviction to a fine not exceeding two hundred pounds or imprisonment for a term not exceeding six months or both.

Dangerous flying.

(2) In any proceedings against the owner of an aircraft in respect of an alleged offence under this section, it shall be a defence to prove that the act alleged to constitute the offence was done without the knowledge and consent of the owner.

(3) In this section "owner", in relation to an aircraft and an alleged offence, includes any person by whom the aircraft is hired at the time of the alleged offence.

(4) Nothing in subsection (1) of this section shall be construed as derogating from the powers conferred by section one of this Act.

40 *Control of air transport undertakings, etc.*

4.—(1) The Minister may make regulations—

(a) to secure that aircraft shall not be used in Nigeria by any person—

Licensing of air transport undertakings.

(i) for plying, while carrying passengers or goods for reward, on such journeys or classes of journeys (whether beginning and ending at the same point or at different points) as may be prescribed ;  
or

such flying undertaken for the purpose of any trade or  
may be prescribed,  
the authority of and in accordance with a licence  
by the prescribed authority ; 5  
the circumstances in which a licence may or shall be  
used, revoked or suspended, and in particular as to the 5  
which the licensing authority is to have regard in deciding  
grant or refuse a licence ;  
appeals (if any) from the licensing authority by persons 10  
the grant, refusal, revocation or suspension of a licence ; 10  
the conditions which may be attached to a licence (includ-  
ng as to the fares, freight or other charges to be charged  
er of the licence), and for securing compliance with any  
attached ;  
the information to be furnished by an applicant for, or 15  
of, a licence to such authorities as may be prescribed ; 15  
paying the fees to be paid in respect of the grant of a licence,  
such fees to be specified by such person or authority as 20  
scribed. 20  
Regulations made under this section may provide for the  
penalties for offences against the regulations, not exceed-  
the case of a first offence against any particular provision, a 25  
exceeding five hundred pounds or imprisonment for a term 25  
not exceeding three months or both ; and  
the case of a second or subsequent offence against the same  
a fine not exceeding five thousand pounds or imprisonment  
not exceeding two years or both.  
The Minister may make regulations— 30  
regarding any person who carries on the business of carrying 30  
or goods in aircraft for reward, on such journeys or classes  
as (whether beginning and ending at the same point or at  
points) as may be prescribed, to furnish to the prescribed  
such information relating to the use of aircraft for the 35  
of the business, and to the persons employed in connection 35  
with it, as may be prescribed ; and  
specifying the times at which, and the form and manner in  
which the information required under the regulations is to be 40  
furnished. 40  
Regulations under this section may provide for the imposition 40  
of penalties for offences against the regulations, not exceeding in the  
particular offence a fine of twenty pounds and a further  
penalty of twenty pounds for every day on which the offence continues after 45  
the first day on which it is committed. 45  
Regulations made under this section shall, in relation to any  
information with respect to any particular undertaking 45  
obtained by virtue of regulations under this section shall,  
except in so far as may be otherwise provided, be in force  
only in relation to that undertaking, and shall not, otherwise  
than in connection with the execution of the regulations,  
be used for any purpose other than that for which the information  
was obtained. 50  
If any person discloses any such information in contraven-

tion of this subsection he shall be liable, on summary conviction, to imprisonment for a term not exceeding three months or a fine not exceeding fifty pounds or both or, on conviction on indictment, to imprisonment for a term not exceeding two years or a fine not exceeding one hundred pounds or both.

(4) Nothing in the last foregoing subsection shall apply to the disclosure of any information for the purposes of any legal proceedings which may be taken by virtue of that subsection or of regulations made under this section, or for the purposes of any report of such proceedings; but save as aforesaid that subsection shall, in relation to any legal proceedings (including arbitration), preclude any person who is in possession of any information obtained by virtue of such regulations from disclosing, and from being required by any court or arbitrator to disclose, that information without the consent of the person carrying on the undertaking to which the information relates.

*Provision of airports and control of land for aviation purposes*

6.—(1) The Minister may establish and maintain airports and may provide and maintain, in connection with airports established by him, roads, approaches, apparatus, equipment and buildings and other accommodation.

Power of  
Minister to  
provide  
airports, etc.

(2) For the avoidance of doubt it is hereby declared that the following purposes are public purposes of the Federation within the meaning of the Public Lands Acquisition Act, that is to say—

Cap. 167.

(a) the purposes of subsection (1) of this section; and

(b) the purpose of securing that land in the vicinity of the site of an airport which the Minister has established or acquired or is about to establish or acquire shall not be used in such a manner as to cause interference with, or danger or damage to, aircraft at, approaching or leaving the airport.

7.—(1) The Minister may, if he is satisfied that it is necessary so to do in order to secure the safe and efficient use for civil aviation purposes of any land, structure, works or apparatus vested in him or which he proposes to acquire or instal, by order declare that any area of land specified in the order shall be subject to control by directions given in accordance with the following provisions of this section.

Control  
of land  
in the  
interests of  
aviation.

(2) Where any such order is in force, the Minister may, in accordance with provisions of the order in that behalf, give directions—

(a) for requiring the total or partial demolition of any building or structure within the area to which the order relates;

(b) for restricting the height of trees and other vegetation upon any land within the area, or for requiring any tree or other vegetation upon any such land to be cut down or reduced in height;

or extinguishing any private right of way over land within the

for restricting the installation of cables, mains, pipes, wires or apparatus over, on or under any land within the area ;

for extinguishing, at the expiration of such period as may be specified by the directions, any subsisting right of installing or maintaining any such apparatus as aforesaid over, on or under any land within the area ; and

for requiring that, before the expiration of such period as may be specified by the directions, any such apparatus shall be removed from any land within the area.

An order under this section may contain provision for empowering any person authorised in that behalf by the Minister to move or remove any structure or as to bring it into conformity with the requirements of any directions given under the order, any building, structure, vegetation or apparatus which contravenes those requirements.

Where the Minister makes or has under consideration the making of an order under this section in respect of any land, any person authorised in that behalf by the Minister may at all reasonable times enter upon the land in order to make any survey which the Minister requires to be made for the purposes of any steps to be taken in consequence of the order or, as the case may be, for the purpose of determining whether the order should be made ;

Provided that admission shall not, by virtue of this subsection, be treated as of right to any land which is occupied unless twenty-four hours notice in writing of the intended entry has been served on the occupier.

(5) The Minister shall give notice of any direction given in pursuance of this section by publishing the direction in the Gazette of India and by taking such steps as he considers reasonable for ensuring that a copy of the direction is served on each person appearing to be the owner or occupier of any land to which the direction applies.

(6) A person who obstructs any other person in the exercise of any powers conferred upon that other person by virtue of subsection (3) of this section shall be guilty of an offence and liable on conviction to imprisonment for a term not exceeding six months or a fine of an amount not exceeding one hundred pounds or both.

(7) A person who incurs expense or suffers damage by reason of the giving of a direction in pursuance of this section shall be entitled to recover from the Minister adequate compensation in respect of the expense or damage.

(8) The powers of the Minister under this section shall not be construed as prejudicing his power to acquire land for the purpose of carrying out any requirement which might have been imposed under this section in relation to the land.

Indication of presence of obstructions near airports.

8.—(1) If the Minister is satisfied, with respect to any building or structure in the vicinity of an airport to which this section applies, that in order to avoid danger to aircraft flying in that vicinity in darkness or conditions of poor visibility, provision ought to be made (whether by lighting or otherwise) for giving to such aircraft warning of the presence of that building or structure, he may by order authorise (subject to any conditions specified in the order) the proprietor of the airport and any person acting under the proprietor's instructions—

5 (a) to execute, instal, maintain, operate, and as occasion requires to repair and alter, such works and apparatus as may be necessary for enabling such warning to be given in the manner specified in the order ; and

10 (b) so far as may be necessary for exercising any of the powers conferred by the order, to enter upon and pass over (with or without vehicles) any such land as may be specified in the order :

15 Provided that no such order shall be made in relation to any building or structure if it appears to the Minister that there have been made, and are being carried out, satisfactory arrangements for the giving of such warning as aforesaid.

20 (2) The Minister shall, before making any such order as aforesaid—

(a) cause to be published, in such manner as he thinks best for informing persons concerned, notice of the proposal to make the order and of the place where copies of the draft order may be obtained free of charge ; and

25 (b) take into consideration any representations with respect to the order which may, within such period not being less than two months after the first publication of the notice as may be specified therein, be made to him by any person appearing to him to have an interest in any land which would be affected by the order ;

30 and at the end of that period the order may, subject to the provisions of this section, be made with such modifications (if any) of the original draft as the Minister thinks proper.

(3) Every such order as aforesaid shall provide—

35 (a) that, except in a case of emergency, no works shall be executed on any land in pursuance of the order unless, at least fourteen days previously, the proprietor of the airport to which the order relates has served in the manner specified by the order on the occupier of that land, and on every other person known by the proprietor to have an interest in the land, a written notice containing such particulars of the nature of the proposed works, and the manner in which and the time at which it is proposed to execute them, as may be specified by the order ; and

40 (b) that if within fourteen days from the service of the said notice on any person having such an interest the proprietor of the airport receives written objection on the part of that person to the proposals contained in the notice then, except in so far as the objection is withdrawn, no steps shall be taken in pursuance of the notice without the specific authority of the Minister ;

and shall also provide for requiring the proprietor of the airport to which the order relates to pay to any person having an interest in any land affected by the order adequate compensation for any loss or damage which that person may suffer in consequence of the order ; and for the purposes of this subsection any expense reasonably incurred in connection with the lawful removal of any apparatus installed in pursuance of such an order, and so much of any expense incurred in connection with the repair, alteration, demolition or removal of any building, structure or erection to which such an order relates as is attributable to the operation of the order, shall be deemed to be loss or damage suffered in consequence of the order.

(4) The ownership of any thing shall not be taken to be affected by reason only that it is placed in, or affixed to, any land in pursuance of such an order as aforesaid ; and (subject to the provisions of the next following subsection) so long as any such order in respect of an airport is in force, no person shall, except with the consent of the proprietor of the airport, wilfully interfere with any works or things which, to the knowledge of that person, are works or things executed or placed in, on or over any land in pursuance of the order.

If any person contravenes the foregoing provisions of this subsection, he shall be liable on summary conviction to imprisonment for a term not exceeding six months or a fine not exceeding two hundred pounds or both ; and every person who wilfully obstructs a person in the exercise of any of the powers conferred by such an order as aforesaid shall be liable on summary conviction to a fine not exceeding fifty pounds.

(5) Nothing in this section shall operate, in relation to any building or structure, so as to restrict the doing of any work for the purpose of repairing, altering, demolishing or removing the building or structure if—

(a) notice of the doing of the work is given as soon as may be to the proprietor of the airport ; and

(b) the giving of warning of the presence of the building or structure in the manner provided by any order under this section in force in relation thereto is not interrupted.

(6) In this section—

(a) the expression “airport to which this section applies” means—

(i) an airport under the control of the Minister or of the Minister of the government of the Federation responsible for defence ; or

(ii) any premises which, in pursuance of regulations made under section one of this Act, are for the time being licensed as an airport for public use ; and

(b) the expression “proprietor of the airport” means—

(i) in the case of such an airport as is mentioned in sub-paragraph (i) above, the officer in charge of the airport ; and

(ii) in any other case, the holder of the licence issued in respect of the airport in pursuance of this Act.

*Special provisions as to trespass, nuisance, salvage and patents, etc.*

5 9.—(1) No action shall lie in respect of trespass or nuisance by reason only of, or of the ordinary incidents of, the flight of an aircraft having regard to wind, weather and all the circumstances of the case.

Liability in respect of trespass, nuisance surface damage from aircraft.

10 (2) Where loss or damage is caused to any person or property on land or water by, or by a person in or an article or person falling from, an aircraft while in flight, taking off or landing, then, without prejudice to the law relating to contributory negligence, damages in respect of loss or damage shall be recoverable without proof of negligence or intention or other cause of action, as if the loss or damage had been caused by the wilful act, neglect or default of the owner of the aircraft :

15 Provided that where loss or damage is caused as aforesaid in circumstances in which—

(a) damages are recoverable from the owner in respect of the loss or damage by virtue only of the foregoing provisions of this subsection ; and

20 (b) a legal liability is created in some person other than the owner to pay damages in respect of the loss or damage ;

the owner shall be entitled to be indemnified by that other person against any claim in respect of the loss or damage.

25 (3) References in the last foregoing subsection to loss or damage include, in relation to any person, loss of life and personal injury ; and where an aircraft has been bona fide demised or hired out for any period exceeding fourteen days to any other person by the owner of the aircraft and no pilot, commander, navigator or operative member of the crew of the aircraft is in the employment of the owner, the last foregoing subsection shall have effect as if for references to the owner there were substituted references to the person to whom the aircraft has been so demised or hired out.

35 10.—(1) The Minister may make regulations as to the conditions under which noise and vibration may be caused by aircraft on airports and may provide that subsection (2) of this section shall apply to any airport as respects which provision as to noise and vibration caused by aircraft is so made.

Liability in respect of nuisance at airports.

40 (2) No action shall lie in respect of nuisance by reason only of the noise and vibration caused by aircraft on an airport to which this subsection applies by virtue of the foregoing subsection so long as the provisions of the regulations in force under that subsection as respects the airport are complied with.

45 11.—(1) Any services rendered in assisting, or in saving life from, or in saving the cargo or apparel of, an aircraft in, on or over the sea or any tidal water, or on or over the shores of the sea or any tidal water, shall be deemed to be salvage services in all cases in which they would have been salvage services if they had been rendered in relation to a

Applicati to aircraft of law of wreck and salvage.

vessel; and where salvage services are rendered by an aircraft to any property or person, the owner of the aircraft shall be entitled to the same reward for those services as he would have been entitled to if the aircraft had been a vessel.

The foregoing provisions of this subsection shall have effect notwithstanding that the aircraft concerned is a foreign aircraft, and notwithstanding that the services in question are rendered elsewhere than within the limits of the territorial waters of Nigeria.

(2) The Minister may by regulations direct that any provisions of any law for the time being in force in Nigeria which relate to wreck, salvage of life or property or to the duty of rendering assistance to vessels in distress shall, with such modifications (if any) as may be prescribed, apply in relation to aircraft as those provisions apply in relation to vessels.

(3) For the purposes of this section, any provisions of any law in force in Nigeria which relate to vessels laid by or neglected as unfit for sea service shall be deemed to be provisions relating to wreck.

12.—(1) Any lawful entry into Nigeria or any lawful transit across Nigeria, with or without landings, of an aircraft to which this subsection applies shall not entail any seizure or detention of the aircraft or any proceedings against the owner or operator of the aircraft or any other interference with the aircraft by or on behalf of any person in Nigeria on the ground that the construction, mechanism, parts, accessories or operation of the aircraft is or are an infringement of any patent, design or model.

(2) The importation into and storage in Nigeria of spare parts and spare equipment for an aircraft to which this subsection applies and the use and installation thereof in the repair of such an aircraft shall not entail any seizure or detention of the aircraft or of the spare parts or spare equipment or any proceedings against the owner or operator of the aircraft or the owner of the spare parts or spare equipment or any other interference with the aircraft by or on behalf of any person in Nigeria on the ground that the spare parts or spare equipment or their installation are or is an infringement of any patent, design or model.

(3) Subsections (1) and (2) of this section apply—

(a) to any aircraft (other than an aircraft used in military, customs or police services) registered in a country or territory as respects which there is for the time being in force a declaration made by the Minister, with a view to the fulfilment of the relevant provisions of the convention mentioned in section one of this Act, that the benefit of those subsections extends to that country or territory; and

(b) to such other aircraft as the Minister may by order specify:

Provided that subsection (2) of this section shall not apply in relation to any spare parts or spare equipment which are sold or distributed in Nigeria or are exported from Nigeria for sale or distribution.

(4) Where it is alleged by any person interested that a foreign aircraft which is not an aircraft to which subsection (1) of this section applies and which is making a passage through or over Nigeria infringes in itself or part of it any invention, design or model which is entitled to

protection in Nigeria, it shall be lawful, subject to and in accordance with rules made by the Minister, to detain the aircraft until the owner of it deposits or secures in respect of the alleged infringement a sum thereupon the aircraft shall not, during the continuance of the passage, be subject to any lien, arrest, detention or prohibition, whether by order of a court or otherwise, on account of the alleged infringement.

5

(5) The deposited sum shall be such sum as may be agreed between the parties interested or, in default of agreement, as may be fixed by the Minister; and the payment of the deposited sum shall be made or secured to the Minister in such manner as may be specified by rules

10

(6) The deposited sum shall be dealt with by such tribunal and in accordance with such procedure as may be prescribed by rules made by the Minister, and the rules may provide generally for carrying the provisions of subsections (4) and (5) of this section into effect.

15

(7) For the purposes of subsection (4) of this section, the expression "owner" shall include the actual owner of an aircraft and any person claiming through or under him, and the expression "passage" shall include all reasonable landings and stoppages in the course of the passage.

20

#### General

13.—(1) Any act done by any person on a Nigerian aircraft outside Nigeria which, if it had been done by him in any part of Nigeria, would have constituted an offence under the law in force in that part shall, for the purposes of any criminal proceedings in that part of Nigeria against that person in respect of that act, be deemed to have been done by him in that part of Nigeria.

25

Offences-

(2) Except with the consent of the Attorney-General of the Federation, no proceedings shall be instituted by virtue of the foregoing subsection against a person who was not a citizen of Nigeria at the time of the act in question.

30

(3) Where it is alleged that an offence under this Act or regulations made by virtue of this Act has been committed, proceedings in respect of the offence may be brought in any court in Nigeria which would have had jurisdiction in the matter if the offence had been committed in the part of Nigeria for which the court acts.

35

14. A person claiming compensation in pursuance of any provision in that behalf of this Act or of an instrument made by virtue of this Act may, for the purpose of determining his interest in the subject-matter of the claim and the amount of the compensation, apply—

40

Compensa-  
tion.

(a) where the subject matter of the claim or the usual residence of the claimant is situated in any territory within the meaning of the Constitution of the Federation, to the High Court of that territory;

(b) in any other case, to the High Court of Lagos.

45

15.—(1) The Minister may by regulations provide that this Act shall bind the state to such extent as may be prescribed.

50

Application  
of Act to the  
state.

(2) Nothing in the foregoing subsection shall be construed as prejudicing the operation of provisions of this Act referring expressly to a Minister or to a person subject to the control of a Minister.

16.—(1) Any regulations, rules or order made by the Minister in pursuance of this Act may contain—

(a) such incidental, supplemental, consequential and transitional provisions; and

(b) such provisions as to the extra-territorial operation of the instrument in question, as the Minister considers expedient for the purposes of the regulations, rules or order. 5

(2) Without prejudice to the generality of the foregoing subsection, regulations under this Act may, for the purpose of securing compliance with the regulations, include provision for the detention of any aircraft in which the regulations relate. 10

17.—(1) In this Act, unless the context otherwise requires, the following expressions have the meanings hereby assigned to them respectively, that is to say—

“airport” means any area of land or water designed, equipped, set apart or commonly used for affording facilities for the landing and departure of aircraft; 15

“foreign aircraft” means an aircraft other than a Nigerian aircraft;

“the Minister” means the Minister of the government of the Federation responsible for civil aviation; 20

“Nigerian aircraft” means an aircraft registered in Nigeria in pursuance of regulations made under section one of this Act; and

“prescribed” means prescribed by regulations made under this Act.

(2) Any power conferred by this Act is in addition to and not in derogation of any other power so conferred. 25

18.—(1) Subject to the following subsection, the enactments specified in the first and second columns of the Schedule to this Act are hereby repealed to the extent shown in the third column of that Schedule.

(2) Anything done under any enactment repealed by the foregoing subsection shall be deemed to have been done under the corresponding provision of this Act; so however that— 30

(a) without prejudice to the provisions of section sixteen of this Act, nothing in the foregoing provisions of this subsection shall be construed as continuing in force any order, regulations or other instrument of a legislative character having effect by virtue of an enactment so repealed; and 35

(b) without prejudice to the operation of section six of the Interpretation Act, 1964 (which relates to the effect of repeals), nothing in the foregoing provisions of this subsection or in the foregoing subsection shall affect any proceedings pending on the day when the foregoing subsection comes into force, and accordingly any such proceedings may be continued as if that subsection had not been passed. 40

19.—(1) This Act may be cited as the Civil Aviation Act, 1964, and shall, without prejudice to the operation of any provision of this Act having or relating to extra-territorial effect, apply throughout the Federation. 45

(2) This Act shall come into force on such day as the Minister may by order appoint, and different days may be so appointed as respects different provisions of this Act.

## SCHEDULE

Section 18.

## Enactments repealed

<i>Chapter or number</i>	<i>Short title</i>	<i>Extent of repeal</i>
Cap. 8.	The Air Navigation (Safety of Navigation) Act.	The whole Act.
Cap. 33.	The Civil Aviation (Births, Deaths and Missing Persons) Act.	The whole Act.
1962, No. 30.	The Merchant Shipping Act, 1962.	In section four hundred and twenty-seven, paragraph (p). The whole Act.
1963, No. 17.	The Director of Civil Aviation (Transfer of Functions) Act, 1963.	
S.I. 1952 No. 868, 1953 Nos. 591 and 1669, 1954 No. 830, 1955 No. 709, 1958 No. 1514, and 1959 No. 1052.	The Colonial Civil Aviation (Application of Act) Orders, 1952 to 1959.	The whole of the Orders.



GULF OIL COMPANY TRAINING FUND  
(ADMINISTRATION) BILL

EXPLANATORY MEMORANDUM

With moneys provided by the Gulf Oil Company it is intended to establish a fund to be known as the Gulf Oil Company Training Fund.

Provision is made in this Bill for administration of the Fund which will be used for the training of Nigerians in the different aspects of the petroleum industry ; and to endow faculties in Nigerian Institutions of Higher Learning.

YUSUFF MAITAMA SULE,  
*Minister of Mines and Power*

ARRANGEMENT OF CLAUSES

*Clause*

- |   |   |
|---|---|
| <ol style="list-style-type: none"> <li>1. Establishment of the Gulf Oil Company Training Fund.</li> <li>2. Purposes of the fund.</li> </ol> | <ol style="list-style-type: none"> <li>3. Disbursements from the fund.</li> <li>4. Enactment amended.</li> <li>5. Short title and application.</li> </ol> |
|---|---|

**A BILL**

FOR

AN ACT TO ESTABLISH AND ADMINISTER A FUND TO BE KNOWN AS THE GULF OIL COMPANY TRAINING FUND AND FOR PURPOSES CONNECTED THEREWITH.

[ ]

BE IT ENACTED by the Legislature of the Federation of Nigeria in this present Parliament assembled and by the authority of the same as follows :—

- |   |   |  |
|---|---|--|
| <ol style="list-style-type: none"> <li>5</li> <li>10</li> <li>15</li> </ol> | <ol style="list-style-type: none"> <li>1. There shall be established a fund to be known as the Gulf Oil Company Training Fund (in this Act hereafter referred to as "the fund") into which shall be paid all moneys received in terms of an agreement made between the said Company and the Government of the Federation that is to say—             <ol style="list-style-type: none"> <li>(a) the sum of one hundred and ninety-three thousand, one hundred and thirteen pounds received as part of the moneys so payable ; and</li> <li>(b) any further sums from time to time payable under the said agreement ;</li> </ol> </li> <li>and moneys in the fund together with interest (if any) payable in respect thereof shall be applied by the Minister of the government of the Federation responsible for mines and power for any of the purposes set out in section two of this Act.</li> </ol> | <p>Commence-<br/>ment.</p> <p>Establish-<br/>ment of the<br/>Gulf Oil<br/>Company<br/>Training<br/>Fund.</p> |
|---|---|--|

Purposes of  
the fund.

2. The fund shall be available for purposes of training Nigerians as technicians or craftsmen as the case may be in the fields of engineering, science and administration in so far as they relate to the petroleum industry, and to this end the fund may be used—

(a) to provide scholarships in universities and institutions ; 5

(b) to maintain or subsidise any such training ; or

(c) to make any suitable endowments to faculties in Nigerian Universities, Colleges, or approved institutes ; and

(d) to make available suitable books and training equipment in the aforesaid fields. 10

Disburse-  
ments from  
the fund.  
No. 33 of  
1958.

3. Disbursements from the fund shall be made in accordance with rules made under section twenty-three of the Finance (Control and Management) Act 1958.

Enactment  
amended.  
No. 33 of  
1958.

4. The First Schedule to the Finance (Control and Management) Act, 1958, is amended by the insertion immediately after item 11 in Part II of the following item— 15

“(12) Gulf Oil Company Training Fund :

The fund established by section one of the Gulf Oil Company Training Fund (Administration) Act, 1964, for the purposes specified in section two of that Act.” 20

Short title  
and  
application.

5. This Act may be cited as the Gulf Oil Company Training Fund (Administration) Act, 1964, and shall apply throughout the Federation.

(916)

The following Bill, which will in due course be presented to Parliament for enactment, is published for general information.

## PHARMACISTS BILL

### EXPLANATORY MEMORANDUM

The existing Pharmacy Act (Cap. 152) relates to both pharmacists and pharmaceutical practice. However, as Federal Government legislative competence is at present limited to pharmacists, it is necessary to separate matters relating to pharmacists from the existing omnibus Act and make them the subject of separate legislation. This is sought to be achieved by this Bill.

The provisions of the Bill are designed to rationalise the basis of the education, qualification, registration and the discipline of pharmacists.

M. A. MAJEKODUNMI,  
*Federal Minister of Health*

### ARRANGEMENT OF CLAUSES

#### Clause

##### *The Pharmacists Board of Nigeria*

1. Establishment of Pharmacists Board
2. Financial provisions.
3. Control of board by the Minister.

##### *The Register*

4. Appointment of registrar and preparation etc. of registers.
5. Publication of registers and lists of corrections.

##### *Registration*

6. Examination qualifications.
7. Registration of members.
8. Approval of courses, qualifications and institutions.
9. Supervision of instruction and examinations leading to approved qualification.

##### *Professional discipline*

10. Establishment of disciplinary committee and investigating panel.

##### *Miscellaneous and general*

11. Penalties for unprofessional conduct, etc.
12. Offences.
13. Employment in the public service or the armed forces.
14. Miscellaneous supplementary provisions.
15. Regulations, rules and orders.
16. Transitional provisions and repeals.
17. Change of title of Pharmacy Act.
18. Interpretation, etc.
19. Short title, extent and commencement.

##### *Schedules*

1. Supplementary provisions relating to the pharmacists board.
2. Supplementary provisions relating to the disciplinary committee and investigating panel.
3. Enactment repealed and enactment amended.
4. Enactment affected.



# A BILL

FOR

AN ACT TO MAKE BETTER PROVISION FOR THE REGULATION OF PHARMACEUTICAL CHEMISTS AND FOR PURPOSES CONNECTED THEREWITH: AND TO AMEND CONSEQUENTIALLY THE PHARMACY ACT.

[Section 19(2)]

BE IT ENACTED by the Legislature of the Federation of Nigeria in this present Parliament assembled and by the authority of the same as follows:—

Commence-  
ment.

*The Pharmacists Board of Nigeria*

- 5     1.—(1) There shall be established a body to be known as the Pharmacists Board of Nigeria (in this Act referred to as "the board") which under that name shall be a body corporate with perpetual succession and a common seal and be charged with the general duty of—
- Establish-  
ment of  
Pharmacists  
Board.
- 10     (a) determining what standards of knowledge and skill are to be attained by persons seeking to become pharmaceutical chemists (in this Act referred to as "pharmacists") and raising those standards from time to time as circumstances may permit;
- 15     (b) securing in accordance with the provisions of this Act the establishment and maintenance of—
- (i) a register of pharmacists, and
- (ii) a register to be known as "the provisional register" of such other persons as the board may recognise for the purposes of this Act,
- 20     and thereafter securing the publication from time to time by the secretary to the board of lists of those persons whose names are entered in such registers; and
- (c) performing the other functions conferred on the board by this Act.
- 25     (2) Subject to the provisions of this Act, the board shall consist of a chairman and members appointed by the Minister and shall comprise,—
- (a) the chief pharmacist of the Federal Ministry of Health who shall be chairman; and
- 30     (b) the following persons, namely,—
- (i) the president of the Pharmaceutical Society of Nigeria,
- (ii) the chief pharmacist or as the case may be, the principal pharmacist in each Region,
- (iii) the heads of pharmacy sections of institutions in Nigeria approved by the board,
- 35     (iv) one member nominated by the council of the pharmaceutical society of Nigeria,
- 40     (v) one member from each Region and one member from the Federal territory nominated from those territories by the respective branches of the pharmaceutical society of Nigeria after consultation with the Minister.

(3) The provisions of the First Schedule to this Act shall have effect with respect to the qualifications and tenure of office of members of the board, and of the powers and procedure of the board and other matters there mentioned.

(4) Regulations may provide for increasing or reducing the membership of the board. 5

2.—(1) The board shall prepare and submit to the Minister, not later than the first day of September of the year in which this subsection comes into force and of each subsequent year, an estimate of its expenditure and income during the next succeeding financial year. 10

(2) The board shall keep proper accounts in respect of each financial year, and proper records in relation to those accounts, and shall cause its accounts to be audited as soon as may be after the end of the financial year to which the accounts relate by a firm of auditors approved, as respects that year, by the Minister of the government of the Federation responsible for finance. 15

(3) The Minister may, out of moneys provided by Parliament, make to the board either by way of grant or by way of loan, payments of such amounts as Parliament may from time to time determine.

of  
y the  
3.—(1) The Minister may give to the board directions of a general character or relating generally to particular matters (but not to any individual person or case) with regard to the exercise by the board of its functions, and it shall be the duty of the board to comply with the directions. 20

(2) Before giving a direction under subsection (1) of this section, the Minister shall serve a copy of the proposed direction on the board and shall afford the board an opportunity of making representations to him with respect to the direction; and after considering any representations made to him in pursuance of this subsection the Minister may give direction either without modification or with such modifications as appear to him to be appropriate having regard to the representations. 25 30

#### The Register

f  
and  
ion  
4.—(1) There shall, on the recommendation of the board be appointed as registrar of the board a fit person who shall be a pharmaceutical chemist in the employ of the Public Service of the Federation: 35  
Provided that the registrar may also be the secretary with the approval of the Minister.

(2) There may likewise be so appointed a deputy registrar and such other officers and employees as may from time to time be necessary for the purposes of this Act.

(3) The registrar shall in accordance with rules made by the board under this section, prepare and maintain a register of the names, addresses and approved qualifications and of such other particulars as may be specified of all persons who are entitled to be registered under this Act and who apply in the specified manner to be so registered. 40

(4) Subject to the following provisions of this section, the board shall make rules with respect to the form and keeping of the registers and the making of entries therein, and in particular—

5 (a) regulating the making of applications for registration and providing for the evidence to be produced in support of applications;

(b) providing for the notification to the registrar, by the person to whom any registered particulars relate, of any change in those particulars;

10 (c) specifying the fees to be paid to the board in respect of the entry of names on the registers and authorising the registrar to refuse to enter a name on a register until any fee specified for the entry has been paid;

(d) specifying anything falling to be specified under the foregoing provisions of this section;

15 but rules made for the purposes of paragraph (d) of this subsection shall not come into force until they are confirmed by order of the Minister.

(5) It shall be the duty of the registrar—

20 (a) to correct, in accordance with the directions of the board, any entry in a register which the board directs him to correct as being in the opinion of the board an entry which was incorrectly made;

(b) to make from time to time any necessary alterations in the registered particulars of registered persons; and

25 (c) to remove from the relevant register the name of any registered person who has died, or unless exempted fails after the expiration of one year to pay a retention fee under this Act.

(6) If the registrar—

30 (a) sends by post to any registered person a registered letter addressed to him at his address on the register enquiring whether the registered particulars relating to him are correct and receives no reply to the letter within the period of six months from the date of posting it; and

(b) upon the expiration of that period sends in like manner to the person in question a second similar letter and receives no reply to that letter within three months from the date of posting it,

35 the registrar may remove the particulars relating to the person in question from the relevant register; and the board may direct the registrar to restore to the appropriate register any particulars removed therefrom under this subsection.

5.—(1) It shall be the duty of the registrar—

40 (a) to cause the registers to be printed, published and put on sale to members of the public not later than two years from the beginning of the year in which this section comes into force; and

45 (b) in each year after that in which a register is first published under paragraph (a) of this subsection to cause to be printed, published and put on sale as aforesaid a corrected edition of the registers or as the board thinks fit a list of corrections made to the registers since they were last printed; and

Publication  
of registers  
and lists of  
corrections.

(c) to cause a print of each edition of the registers and of the list of corrections to be deposited at the principal office or offices, as the case may be, of the board ;

and it shall be the duty of the board to keep the registers and lists so deposited, open at all reasonable times for inspection by members of the public.

(2) A document purporting to be a print of an edition of a register published under this section by authority of the registrar in the current year or documents purporting to be prints of an edition of a register so published in a previous year and of a list of corrections to that edition so published in the current year shall, as an alternative to any other mode of proof in any proceeding be admissible as evidence that any person specified in the document or in the documents if read together, as being registered under this Act—

(a) is so registered, or

(b) is so registered subject to payment of the annual retention fee ; and that if not specified in the registers he is not so registered.

(3) The registers shall show in an appropriately headed column when the annual licence fee was last paid by each person appearing as registered therein, unless exempted under this Act.

#### Registration

6.—(1) The board shall from time to time arrange for the examination of candidates as pharmacists and for the issue of diplomas under the provisions of this Act ; and for such purpose the board may prescribe fees and appoint examiners from time to time at such remuneration as the Minister may approve.

(2) The board may exempt any person from the requirements of examination under this section either wholly or in part where it is satisfied that such person is the holder of a diploma issued by any authority outside Nigeria ; and if such holder is not a citizen of Nigeria, he shall, in addition, satisfy the board that he has been resident in Nigeria for not less than twelve months immediately preceeding the date of application for exemption.

(3) A diploma issued under this section shall show that the person named therein is qualified to apply for registration as a pharmacist ; and if an applicant is thereafter so registered under this Act he shall, upon payment of the prescribed fee, be entitled to an annual licence to practise as a pharmacist accordingly.

7.—(1) An applicant for registration shall unless otherwise precluded by this Act, be entitled to be registered as a pharmacist if he satisfies the board—

(a) that he is of good character, and is the holder of—

(i) a diploma under this Act, or

(ii) a qualification granted outside Nigeria and for the time being accepted by the board for the purpose of this subsection ; and

(b) if the board so requires, that he has had sufficient practical experience as a pharmacist.

(2) Any person aggrieved by a decision of the Board under this section may appeal to the Minister within one month after notice is given to him of the decision.

(3) For the purposes of this section, the board shall from time to time publish in the gazette particulars of the qualifications for the time being accepted by the board.

8.—(1) The board may approve—

5 (a) any course of training which is intended for persons who are seeking to become, or are already, pharmacists and which the board considers is designed to confer on persons completing it sufficient knowledge and skill for the practice of that profession ;

10 (b) any institutions, either in Nigeria or elsewhere, which the board considers is properly organised and equipped for conducting the whole or any part of a course of training approved by the board under this section ;

15 (c) any qualification which, as a result of an examination taken in conjunction with a course of training approved by the board under this section, is granted to candidates reaching a standard at the examination indicating, in the opinion of the board, that they have sufficient knowledge and skill to practise the profession of a pharmacist.

20 (2) The board may, if it thinks fit, withdraw any approval given under this section in respect of any course, qualification or institution ; but before withdrawing such an approval the board shall—

(a) give notice that it proposes to do so to each person in Nigeria appearing to the board to be a person by whom the course is conducted or the qualification is granted or the institution is controlled, as the case may be ; and

25 (b) afford each such person an opportunity of making to the board representations with regard to the proposal ; and

(c) take into consideration any representations made as respects the proposal in pursuance of the last foregoing paragraph.

30 (3) As respects any period during which the approval of the board under this section for a course, qualification or institution is withdrawn, the course, qualification or institution shall not be treated as approved under this section ; but the withdrawal of such an approval shall not prejudice the registration or eligibility for registration of any person who by virtue of the approval was registered or eligible for registration

35 immediately before the approval was withdrawn.

(4) The giving or withdrawal of an approval under this section shall have effect from such date, either before or after the execution of the instrument signifying the giving or withdrawal of the approval, as the board may specify in that instrument ; and the board shall—

40 (a) as soon as may be publish a copy of every such instrument in the gazette ; and

(b) not later than seven days before its publication as aforesaid, send a copy of the instrument to the Minister.

45 9.—(1) It shall be the duty of the board to keep itself informed of the nature of the instruction given at approved institutions to and examinations taken by persons attending approved courses of training and for the purposes of performing that duty the board may appoint, either from among its own members or otherwise, persons to visit approved institutions or to attend such examinations.

Approval of  
courses,  
qualifica-  
tions and  
institutions.

Supervision  
of instruct-  
and exami-  
tions lead  
to approve  
qualifica-

It shall be the duty of a visitor appointed under this subsection to the board on—

(1) the sufficiency of the instruction given to persons attending approved courses of training at institutions visited by him ;

(2) the sufficiency of any examinations attended by him ; and 5

(3) any other matters relating to the institutions or examinations which the board may, either generally or in a particular case, request him to report ;

no visitor shall interfere with the giving of any instruction or the giving of any examination. 10

(3) On receiving a report made in pursuance of this section, the board shall as soon as may be send a copy of the report to the person appearing to the board to be in charge of the institution or responsible for the examinations to which the report relates requesting that person to make observations on the report to the board within such period as may be specified in the request, not being less than one month beginning from the date of the request. 15

#### Professional Discipline

10.—(1) There shall be a committee to be known as the Pharmacists Disciplinary Committee (in this Act hereafter referred to as the "disciplinary committee") which shall be charged with the duty of considering and determining any case referred to it by the panel established by the following provisions of this section, and any other case of which the disciplinary committee has cognisance under the following provisions of this Act. 20

(2) The disciplinary committee shall consist of the chairman of the board and eleven other members of the board appointed by the board and shall include not less than five members of the board holding office by virtue of sub-paragraphs (iv) and (v) of paragraph (b) of sub-section (2) of section one of this Act, or where the number of those members is for the time being less than five, all those members. 25

(3) There shall be a body, to be known as the Pharmacists Investigating Panel (in this Act hereafter referred to as "the panel"), which shall be charged with the duty of— 30

(a) conducting a preliminary investigation into any case where it is alleged that a registered person has misbehaved in his capacity as a pharmacist or should, for any other reason be the subject of proceedings before the tribunal ; and 35

(b) deciding whether the case should be referred to the tribunal.

(4) The panel shall consist of five members to be appointed by the board and shall include one qualified in law to be appointed on the recommendation of the Attorney-General of the Federation ; and the secretary shall be the secretary of the panel, but shall not have a vote. 40

(5) The provisions of the Second Schedule to this Act shall, in so far as they are applicable to the disciplinary committee and the panel respectively, have effect with respect to those bodies. 45

*Miscellaneous and General*

11.—(1) Where—

(a) a registered person is judged by the disciplinary committee to be guilty of infamous conduct in any professional respect ; or

5 (b) a registered person is convicted, by any court in Nigeria or elsewhere having power to award imprisonment, of an offence (whether or not an offence punishable with imprisonment) which in the opinion of the disciplinary committee is incompatible with the status of a pharmacist ; or

10 (c) the disciplinary committee is satisfied that the name of any person has been fraudulently registered, the disciplinary committee may, if it think fit, give a direction reprimanding that person or ordering the registrar to strike his name off the relevant register or registers.

15 (2) The disciplinary committee may, if it thinks fit, defer or further defer its decision as to the giving of a direction under the foregoing subsection until a subsequent meeting of the disciplinary committee ; but—

(a) no decision shall be deferred under this subsection for periods exceeding two years in the aggregate ; and

20 (b) no person shall be a member of the disciplinary committee for the purposes of reaching a decision which has been deferred or further deferred unless he was present as a member of the disciplinary committee when the decision was deferred.

25 (3) For the purposes of subsection (1) of this section a person shall not be treated as convicted as mentioned in paragraph (b) of that subsection unless the conviction stands at a time when no appeal or further appeal is pending or may (without extension of time) be brought in connection with the conviction.

30 (4) When the disciplinary committee gives a direction under subsection (1) of this section, the disciplinary committee shall cause notice of the direction to be served on the person to whom it relates.

35 (5) The person to whom such a direction relates may, at any time within twenty-eight days from the date of service on him of the notice of the direction, appeal against the direction to the Supreme Court ; and the disciplinary committee may appear as respondent to the appeal and, for the purpose of enabling directions to be given as to the costs of the appeal and of proceedings before the disciplinary committee, shall be deemed to be a party thereto whether or not it appears on the hearing of the appeal.

40 (6) A direction of the disciplinary committee under subsection (1) of this section shall take effect—

(a) where no appeal under this section is brought against the direction within the time limited for the appeal, on the expiration of that time ;

45 (b) where such an appeal is brought and is withdrawn or struck out for want of prosecution, on the withdrawal or striking out of the appeal ;

Penalties for unprofessional conduct, etc.

where such an appeal is brought and is not withdrawn or struck  
 aforesaid, if and when the appeal is dismissed ;  
 shall not take effect except in accordance with the foregoing pro-  
 of this subsection.

A person whose name is removed from a register in pursuance  
 direction of the disciplinary committee under this section shall  
 entitled to be registered in that register again except in pursuance  
 direction in that behalf given by the disciplinary committee on the  
 tion of that person ; and a direction under this section for the  
 l of a person's name from a register may prohibit an application  
 his subsection by that person until the expiration of such period  
 the date of the direction (and where he has duly made such an  
 tion, from the date of his last application) as may be specified  
 direction.

2.—(1) Unless otherwise exempted under this Act, any person,  
 being a fully registered pharmacist or, being a fully registered  
 acist and allowing his licence to expire so that payment of the  
 bided fee is in arrears for more than one year, who—

a) for or in expectation of reward practises or holds himself out  
 pharmacist ; or

b) takes or uses any letters after his name to indicate qualification  
 pharmaceutical chemist ; or

c) without reasonable excuse takes or uses any name, title, addition  
 description implying that he is authorised by law to practise as a  
 pharmacist,

shall be guilty of an offence.

2) If any person, for the purpose of procuring the registration of  
 name, qualification or other matter—

a) makes a statement which he believes to be false in a material  
 particular ; or

b) recklessly makes a statement which is false in a material parti-  
 cular,

shall be guilty of an offence.

3) If the registrar or any other person employed by the board  
 makes any falsification in any matter relating to the register he  
 shall be guilty of an offence.

4) A person guilty of an offence under this section shall be liable—

a) on summary conviction, to a fine not exceeding fifty pounds ;

b) on conviction on indictment, to a fine not exceeding five hundred

pounds or imprisonment for a term not exceeding two years or to both.

Where an offence under this section which has been committed  
 by a body corporate is proved to have been committed with the consent  
 or connivance of, or to be attributable to any neglect on the part of, any  
 officer, manager, secretary or other similar officer of the body corporate,  
 or any person purporting to act in any such capacity, he, as well as the  
 body corporate, shall be deemed to be guilty of that offence and shall  
 be liable to be proceeded against and punished accordingly.

13.—(1) A person shall not hold an appointment as a pharmacist in the public service of the Federation or of a Region or in the armed forces of the Federation unless—

- (a) he is the holder of an annual licence to practise as a pharmacist ;  
 5 or  
 (b) he is, as the holder of a diploma granted by the board or of some other approved qualification, exempted from the requirement of an annual licence fee.

Employment  
in the public  
service or  
the armed  
forces.

(2) The Minister may by order in the gazette exempt any class or classes of persons from the requirements of this Act as to annual licences for such period or periods as he thinks fit ; and may at any time amend, vary or revoke any such notice.

14.—(1) A fully registered pharmacist shall be entitled to practise as a pharmaceutical chemist throughout the Federation.

(2) Without prejudice to the rule of law whereby a contract may be void if it is inconsistent with the provisions of an enactment, no person other than a fully registered pharmacist shall be entitled to bring any proceedings in any court of law for the purpose of recovering any fee or other consideration whatsoever payable in respect of services rendered or facilities or things supplied by him when purporting to act as a pharmaceutical chemist.

Miscellaneous  
supplementary  
provisions.

(3) It shall be the duty of the person in charge of each school of pharmacy, university or similar institution in the Federation at which there is held a course of training intended for persons who are seeking to become members of the pharmaceutical profession to furnish to the registrar, not later than the thirty-first day of March in every year, a list of the names, and of such other particulars as the board may by order specify, of all persons who attended any such course at the institution in question at any time during the preceding year.

15.—(1) Any power to make regulations, rules or orders conferred by this Act shall include power—

- (a) to make provision for such incidental and supplementary matters as the authority making the instrument considers expedient for the purposes of the instrument ; and  
 35 (b) to prescribe membership fees in such amount as the Minister may from time to time approve ; and  
 (c) to make different provision for different circumstances.

Regulations,  
rules and  
orders.

(2) The Minister shall lay a copy of all regulations before each House of Parliament as soon as may be after the regulations are made.

16.—(1) A person whose name is not on the register maintained under the Pharmacy Act by reason of its having been removed by order of the Pharmacy Board under that Act shall be deemed for the purposes of this Act to have had his name removed, in pursuance of a direction of the disciplinary committee which took effect on the date when this subsection came into force, from the register maintained under this Act ; and the provisions of subsection (7) of section eleven of this Act shall have effect accordingly as if the direction aforesaid prohibited applications under that subsection for the period of six months.

Transitional  
provisions  
and repeals  
Cap. 152

Pharmacy Act which, immediately that Act relating to such proceedings; the Pharmacy Board established in any court on appeal may be exercised, as if this Act had not the foregoing provisions of this Act, in any order made or judgment proceedings or appeal, but not for proceedings under that Act shall be	5 10
Pharmacy Act shall—	
The Minister may by order appoint the Third Schedule to this Act, and in relation to different provisions	15
Act, as affected by this Act, there- reference to the Federation or to the Act, it shall have effect subject to the Third Schedule, and to the provisions	20
Subsection (2) of this section, the Pharmacy Act shall be abolished.	
Act as is not repealed by this Act may, be cited as the Poisons and Pharmacy	25
After “poisons” up to the end of the Third Schedule shall be repealed; and the words “as the Poisons” shall be substituted for all words in this section, the words “as the Poisons	30
Content mentioned in section nineteen of this Act.	
As context otherwise requires, the meanings hereby assigned to them	35
As being approved under this Act; a qualification which is approved in this Act; the Pharmacy Board of Nigeria; means the Pharmacists Disciplinary Act; the Federation; the Minister of the government of the Federal Republic of Nigeria relating to health; as defined to it by section ten of this Act;	40
As being a pharmacist registered and under this Act; any regulations;	45 50

"register" means a register maintained under this Act, and "registered" shall be construed accordingly;

"the registrar" means the registrar appointed in pursuance of section four of this Act;

"regulations" means regulations made by the Minister.

5

(2) For the purposes of this Act—

(a) a person is fully registered if his name is for the time being entered in the register other than the provisional register; and

10

(b) a person whose name is in the provisional register is one whose qualifications as a pharmacist are provisionally recognised by the board and are subject to the provisions of this Act and regulations made thereunder,

and "registered" shall be construed in accordance with paragraphs (a) and (b) of this subsection.

15

(3) Any approval, consent, direction, notice, observations, report, representation or request authorised or required to be given or made by or under this Act shall be in writing and may, without prejudice to any other method of service but subject to the provisions of rules made under the Second Schedule to this Act, be served by post.

20

19.—(1) This Act may be cited as the Pharmacists Act, 1964, and shall apply throughout the Federation, so however that the provisions of the Fourth Schedule shall, save as to subsection (1) of section forty-nine and subsection (1) of section sixty-nine of the Act there cited, have effect in the Federal territory.

Short title,  
extent and  
commence-  
ment.

25

(2) The provisions of this Act shall come into force on such date as the Minister may by order appoint, and different dates may be appointed for the purposes of different provisions.

## SCHEDULES

Section 1 (4)

### FIRST SCHEDULE

#### SUPPLEMENTARY PROVISIONS RELATING TO THE PHARMACISTS BOARD

##### *Qualifications and tenure of office of members*

1.—(1) A person shall not be a member of the board unless he is a pharmaceutical chemist.

(2) Members other than those appointed by office shall hold office for a period of three years beginning with the date of his appointment as a member, but shall be eligible for reappointment at the expiration of that period.

(3) Any member other than a member appointed by office may at any time resign his appointment by notice in writing under his hand; and the resignation shall have effect upon signification by any means of its acceptance by the Minister.

(4) Members appointed by office shall cease to be members upon ceasing to hold the office entitling appointment to the board.

*the board*

ons of this paragraph, and of any  
is Act, the board shall have power  
is calculated to facilitate the carrying

ower to borrow money or to dispose  
or consent of the Minister.

a scales approved by the Minister,  
ay remuneration (including pensions)  
nber, officer or servant of the board

*ings of the board*

of this Act the board may make  
ceedings of the board or any com-

entative from each of the Regions is  
; the chairman for the meeting shall

at all meetings at which he is present ;  
ending may elect one of their number  
ting.

on shall be decided by a majority of  
nd voting thereon. Every member  
hall have a deliberative vote for the  
ne votes are equal the chairman shall  
ve vote, a casting vote.

isions of standing orders, the board  
roned by the chairman ; and if the  
notice given to him by not less than  
non a meeting of the board to be held  
e when the notice is given.

to obtain the advice of any person on  
co-opt that person as a member for  
person who is a member by virtue of  
towards a quorum.

the board shall, notwithstanding the  
ummoned by the Minister who may  
it as to the procedure which shall be  
er meeting may be convened by the  
refuses to do so.

*ommittees*

nt one or more committees to carry  
of its functions as the board may

nder this paragraph shall consist of  
id by the board, and not more than  
e persons who are not members of

the board ; and a person other than a member of the board shall hold office on the committee in accordance with the terms of the instrument by which he is appointed.

(3) A decision of a committee of the board shall be of no effect until it is confirmed by the board.

#### *Miscellaneous*

9.—(1) The fixing of the seal of the board shall be authenticated by the signature of the chairman or of some other member authorised generally or specially by the board to act for that purpose.

(2) Any contract or instrument which, if made or executed by a person not being a body corporate, would not be required to be under seal may be made or executed on behalf of the board by any person generally or specially authorised to act for that purpose by the board.

(3) Any document purporting to be a document duly executed under the seal of the board shall be received in evidence and shall, unless the contrary is proved, be deemed to be so executed.

10. The validity of any proceedings of the board or a committee thereof shall not be affected by any vacancy in the membership of the board or committee, or by any defect in the appointment of a member of the board or of a person to serve on the committee, or by reason that a person not entitled to do so took part in the proceedings.

11. Any member of the board, and any person holding office on a committee of the board, who has a personal interest in any contract or arrangement entered into or proposed to be considered by the board or a committee thereof shall forthwith disclose his interest to the board and shall not vote on any questions relating to the contract or arrangement.

12. A person shall not, by reason only of his membership of the board, be treated as holding an office of emolument under the State.

### SECOND SCHEDULE

Section 10 (5)

#### SUPPLEMENTARY PROVISIONS RELATING TO THE DISCIPLINARY COMMITTEE AND INVESTIGATING PANEL

##### *The Tribunal*

1. The quorum of the disciplinary committee shall be four, who shall all be pharmacists.

2.—(1) The Chief Justice of Nigeria shall make rules as to the selection of members of the disciplinary committee for the purposes of any proceedings and as to the procedure to be followed and the rules of evidence to be observed in proceedings before such committee.

(2) The rules shall in particular provide—

(a) for securing that notice of the proceedings shall be given, at such time and in such manner as may be specified by the rules, to the person who is the subject of the proceedings ;

(b) for determining who, in addition to the person aforesaid, shall be a party to the proceedings ;

- for securing that any party to the proceedings shall, if he so requires, be entitled to be heard by the disciplinary committee ;
- ) for enabling any party to the proceedings to be represented by a legal practitioner ;
- ) subject to the provisions of subsection (5) of section eleven of the Act, as to the costs of proceedings before the disciplinary committee ;
- ) for requiring, in a case where it is alleged that the person who is the subject of the proceedings is guilty of infamous conduct in any professional respect, that where the disciplinary committee adjudges the allegation has not been proved it shall record a finding that the person is not guilty of such conduct in respect of the matters to which the allegation relates ;
- ) for publishing in the gazette notice of any direction of the disciplinary committee which has taken effect providing that a person's name shall be struck off a register.
4. For the purposes of any proceedings before the disciplinary committee, any member of the said committee may administer oaths to any party to the proceedings may sue out of the registry of the Federal Supreme Court writs of subpoena ad testificandum and duces tecum ; but no person appearing before the said committee shall be compelled—
- (a) to make any statement before the disciplinary committee tending to incriminate himself ; or
- (b) to produce any document under such a writ which he could not be compelled to produce at the trial of an action.
- 4.—(1) For the purpose of advising the disciplinary committee on questions of law arising in proceedings before it, there shall in all such proceedings be an assessor to the said committee who shall be appointed by the board on the nomination of the Chief Justice of Nigeria and shall be a legal practitioner of not less than seven years standing.
- (2) The Chief Justice of Nigeria shall make rules as to the functions of assessors appointed under this paragraph, and in particular such rules shall contain provisions for securing—
- a) that where an assessor advises the disciplinary committee on a question of law as to evidence, procedure or any other matters specified by the rules, he shall do so in the presence of every party or person representing a party to the proceedings who appears thereat if the advice is tendered while the said committee is deliberating in private, that every such party or person as aforesaid shall be informed what advice the assessor has tendered ;
- b) that every such party or person as aforesaid shall be informed in any case the disciplinary committee does not accept the advice of the assessor on such a question as aforesaid.
5. An assessor may be appointed under this paragraph either generally or for any particular proceedings or class of proceedings, and shall hold and vacate office in accordance with the terms of the instrument by which he is appointed.

*The panel*

5. The quorum of the panel shall be three all of whom shall be pharmacists.

6.—(1) The panel may, at any meeting of the panel attended by not less than six members of the panel make standing orders with respect to the panel.

(2) Subject to the provisions of any such standing orders, the panel may regulate its own procedure.

*Miscellaneous*

7.—(1) A person ceasing to be a member of the disciplinary committee or the panel shall be eligible for reappointment as a member of that body.

(2) A person may, if otherwise eligible, be a member of both the disciplinary committee and the panel; but no person who acted as a member of the panel with respect to any case shall act as a member of the said committee with respect to that case.

8. The disciplinary committee or the panel may act notwithstanding any vacancy in its membership; and the proceedings of either body shall not be invalidated by any irregularity in the appointment of a member of that body, or (subject to subparagraph (2) of paragraph 7 above) by reason of the fact that any person who was not entitled to do so took part in the proceedings of that body.

9. The disciplinary committee and the panel may each sit in two or more divisions.

10. Any document authorised or required by virtue of this Act to be served on the disciplinary committee or the panel shall be served on the registrar.

11. Any expenses of the disciplinary committee or the panel shall be defrayed by the board.

12. A person shall not, by reason only of his appointment as a legal assessor to the disciplinary committee or as a member of the panel, be treated as holding an office of emolument under the State.

## THIRD SCHEDULE

PART A—ENACTMENT REPEALED Section 16 (3) (a)

Chapter  
152 Short title  
Pharmacy Act

Extent of repeal  
Part II and Part III except sections 15,  
19, 20, 22, 23, 25 and 26

## PART B—ENACTMENT AMENDED

Sections 16 (3) (b) and 17

apter Short title  
52 Pharmacy Act

## Extent of amendment

In section two, in the definition of—

- (a) "the Board" there shall be substituted for the words "the Pharmacy Board established under this Act" the words "the Pharmacists Board of Nigeria established under the Pharmacists Act, 1964 ;"
- (b) "chemist and druggist" there shall be substituted for the words defined and the interpretation thereof the following definition—  
' "chemist" means a person permitted to practise as a pharmaceutical chemist under the Pharmacists Act, 1964 and authorised under this Act to import, mix, compound, prepare, dispense and sell drugs and poisons, and includes any person who immediately before the commencement of the Pharmacists Act, 1964 was authorised under this Act to so deal in drugs and poisons as a chemist and druggist, which authority or licence, as the case may be, is still in force on the commencement of the Pharmacists Act, 1964, and references in this Act shall be so construed accordingly ;"
- (c) "dispenser" there shall be substituted for all words after "means" the words 'the holder of a certificate as such under any enactment repealed by this Act and duly recognised in the provisional register of the Pharmacists Board of Nigeria' ;
- (d) "Pharmaceutical Registrar" there shall be substituted for the words defined the word "registrar" and in the interpretation thereof and the words "section seven" there shall be substituted the words "the Pharmacists Act, 1964".

In section twenty, for the words in paragraph (b) there shall be substituted the words—

"a pharmacist licensed under the Pharmacists Act, 1964".

<i>Chapter</i>	<i>Short title</i>	<i>Extent of amendment</i>
		In section twenty-two in subsections (2), (4), (6) and (7) for the words "Pharmaceutical Registrar" there shall be substituted the word "registrar".
		In section twenty-three in subsection (1), for the words "Pharmaceutical Registrar" there shall be substituted the word "registrar".
		In section forty-nine in subsection (1) there shall be repealed the words "and druggist".
		In section sixty-nine in subsection (1) there shall be repealed—
		(a) paragraph (b)
		(b) the words "certificates, diploma," in paragraph (c)
		(c) the words "certificate, diploma," in paragraph (d).

---

FOURTH SCHEDULE      Sections 17 and 19 (1)

ENACTMENT AFFECTED

<i>Chapter</i>	<i>Short title</i>	<i>Extent affected</i>
152	Poisons and Pharmacy Act	Sections 1 and 2 of Part I ; Sections 15, 19, 20, 22, 23, 25 and 26 of Part III ; and Part IV to the end of the Act.



The following Bill, which will in due course be presented to Parliament for enactment, is published for general information.

## SUPPLEMENTARY APPROPRIATION (1964-65) BILL, 1964

### EXPLANATORY MEMORANDUM

This Bill makes supplementary provision for the service of the Federation for the year 1964-65, and provides for the repayment of an advance made from the Contingencies Fund.

F. S. OKOTIE-BOH,  
*Minister of Finance*

## A BILL

### FOR

AN ACT TO AUTHORISE THE ISSUE OUT OF THE CONSOLIDATED REVENUE FUND OF EIGHT HUNDRED AND FORTY-SEVEN THOUSAND, FIVE HUNDRED POUNDS FOR THE PURPOSE OF REPLACING ADVANCES FROM THE CONTINGENCIES FUND AND OF MAKING FURTHER PROVISION FOR THE SERVICE OF THE YEAR ENDING ON THE THIRTY-FIRST DAY OF MARCH, ONE THOUSAND NINE HUNDRED AND SIXTY-FIVE ; AND TO APPROPRIATE THAT AMOUNT FOR THE PURPOSE SPECIFIED IN THIS ACT.

[ ]

Commence-  
ment.

BE IT ENACTED by the Legislature of the Federation of Nigeria in this present Parliament assembled and by the authority of the same as follows :—

1. The aggregate amount mentioned in section one of the Appropriation Act, 1964 (which provides for the issue out of the Consolidated Revenue Fund in respect of the year ending on the 31st day of March, 1965, of sums not exceeding in aggregate £62,275,980) shall be increased by eight hundred and forty-seven thousand five hundred pounds ; and the additional amount shall be appropriated—
- 5
- 10 (a) as to five thousand five hundred pounds to the replacement of an advance from the Contingencies Fund ; and
- (b) as to eight hundred and forty-two thousand pounds to heads of expenditure as indicated in the Schedule to this Act ;
- 15 and subsection (3) of section one of the Appropriation Act, 1964 (which provides for the lapse of balances outstanding at the end of the financial year) shall have effect accordingly.

Issue and  
appropria-  
tion of  
£847,500  
from the  
Consoli-  
dated  
Revenue  
Fund f  
Contin-  
gencies  
Fund  
for ser-  
of 196  
1964,  
No. 2

2. This Act may be cited as the Supplementary Appropriation (1964-65) Act, 1964, and shall apply throughout the Federation.

Section 1		SCHEDULE					Amount
Head						£	
23	Police ..	..	..	..	..	115,000	
36	Ministry of Education	..	..	..	..	342,000	
41	Ministry of Finance	..	..	..	..	300,000	
45	Ministry of Health ..	..	..	..	..	15,000	
48	Prisons	..	..	..	..	70,000	
	Total ..	..	..	..	..	<u>£842,000</u>	

The following Bill, which will in due course be presented to Parliament for enactment, is published for general information.

CASINO LICENSING BILL

EXPLANATORY MEMORANDUM

This Bill seeks to provide for the licensing and control of Casino established in the Federal territory. Included in the Bill is a schedule which lays down, amongst other provisions, rules governing the conduct of a Club in which a Casino is established.

ALHAJI SHEHU SHAGARI,  
Federal Minister of Internal Affairs

ARRANGEMENT OF CLAUSES

Clause

- 1. Power of Minister to license, etc., a casino.
- 2. Security for performance by licensee of obligations.
- 3. Notice of licensed premises to be displayed.
- 4. Power of Minister to require information.

- 5. Inspection of premises by police.
- 6. Offences.
- 7. Interpretation.
- 8. Short title, application and commencement.

SCHEDULE—Provisions applicable in respect of casino.



# A BILL

FOR

C 315

AN ACT TO MAKE PROVISION FOR THE LICENSING AND CONTROL OF A CASINO IN THE FEDERAL TERRITORY AND FOR CONNECTED PURPOSES.

BE IT ENACTED by the Legislature of the Federation of Nigeria in this present Parliament assembled and by the authority of the same as follows :—

Commence-  
ment.

1.—(1) It shall be lawful for the Minister by licence under his hand and in such form as he may approve, to authorise any person approved by the Council of Ministers to establish in the Federal territory and operate therein a casino for such period or periods as may be prescribed, anything in any enactment to the contrary notwithstanding.

Power of  
Minister to  
license, etc.  
a casino.

(2) A casino licensed under the foregoing subsection shall be established in such locality as the Minister may approve and shall be operated only as a proprietary club of the licensee; and the provisions of the Schedule to this Act shall apply to such proprietary club, so however, that the Minister with the approval of the Council of Ministers may by order at any time add to, amend, vary, or revoke such provisions,

(3) Regulations may prescribe—

(a) the terms and conditions under which the licence may be issued and the duration of the licence;

(b) the conditions subject to compliance with which the licence may be renewed, amended, varied, or transferred;

(c) the fees payable on application for and issue of the licence;

(d) the games to be played in the casino, and where applicable, the maximum percentage of commission to be taken by the licensee in respect of each game, and the maximum odds to be paid by the licensee;

(e) the minimum reserve fund in cash to be held on any one night by the licensee in the casino;

(f) the conditions subject to which persons may be admitted to the casino;

(g) the measures to be taken for the prevention of fraud on players or on the licensee;

(h) penalties for breach of the regulations not exceeding fifty pounds or imprisonment for three months, or both.

(4) Orders and regulations made under the foregoing provisions of this section shall be laid before both Houses of Parliament on any of the next twenty sitting days after they are made, and if then annulled without prejudice to anything done or purported to have been done under any such orders or regulations.

(5) A licence under this section may be revoked—

(a) if upon complaint by the Inspector-General of Police to the Minister, the Council of Ministers are satisfied that it is a proper case for such action and direct accordingly;

- b) if the Council of Ministers are satisfied it is in the public interest to revoke the licence ; or
- c) If the Minister is satisfied that a court of competent jurisdiction is lower than one presided over by a chief magistrate so recommends the course of any criminal proceeding. 5
- 2.—(1) The Minister may require the licensee to deposit with as security for the due performance of any obligation of the licensee under this or any other Act an amount as may be agreed between the licensee and the Minister not less in any event than two hundred pounds; if default is made in such performance by the licensee, the Minister in his discretion— 10
- (a) if the obligation can be satisfied by the payment of money, notify the licensee that he intends to apply the money so held as security in satisfaction or part satisfaction, as the case may be, of such obligation ; or 15
- (b) arrange with the Council of Ministers for the licence to be revoked.
- (2) Moneys used to satisfy an obligation under the foregoing subsection shall, if the Minister so directs, be replaced by the licensee to the extent necessary to bring the amount held on deposit up to the original sum. 20
3. The licensee shall cause to be prominently displayed in the casino a notice that the premises are so licensed ; and the notice shall show the games authorised to be played, and as the case may be, the maximum percentage of commission to be deducted in play, and the dividends payable. 25
4. The licensee shall at intervals of not more than six months after the commencement of his licence supply to the Minister such information relating to the operation of the casino as may be reasonably necessary to ensure due compliance by the licensee with the requirements of the licence. 30
5. A superior police officer in uniform may, during the course of any play, enter upon the premises occupied by the licensee under this Act ; and, if he has reasonable cause to suspect that they are not lawfully used or operated in the prescribed manner, he may search any part of the premises. 35
- 6.—(1) If a licence is granted under this Act, no person other than the licensee shall be entitled to use the word "casino" in conjunction with his name ; and the failure to comply with the requirement of this section shall be an offence punishable by conviction— 40
- (a) in the case of a body corporate by a fine of not less than five hundred pounds ;
- (b) in any other case, by a fine of not less than one hundred pounds or more than two hundred pounds or by imprisonment of a term of not more than one year, or both such fine and imprisonment ; 45
- the court convicting shall order the offending name to be changed with.
- (2) Any person not duly licensed under this Act, who falsely represents himself to be so licensed, shall be guilty of an offence and liable on conviction— 50

- (a) in the case of a body corporate to a fine of not less than five hundred pounds or more than one thousand pounds ;  
 (b) in any other case to a fine of not less than two hundred pounds or more than five hundred pounds, or imprisonment for a term of two years or both such fine and imprisonment.

7. In this Act unless the context otherwise requires—  
 “casino” means any building or part of a building licensed under this Act to which members of the public authorised by the licensee have access for the purpose, among other things, of playing at prescribed games of chance ;  
 “licence” means a licence issued under section one of this Act ;  
 “the Minister” means the Minister of the Government of the Federation charged with responsibility for Internal Affairs ;  
 “prescribed” means prescribed by this Act or by regulations made under this Act.

Interpretation.

- 8.—(1) This Act may be cited as the Casino Licensing Act 1964 and shall apply to the Federal territory.

- (2) This Act shall come into force on a day to be appointed by the Minister by notice in the gazette.

Short title, application and commencement.

## SCHEDULE

### Section 1

#### PROVISIONS APPLICABLE IN RESPECT OF A CASINO

1. The rules of the club may provide for permanent and temporary membership and they shall be approved by the Minister.
2. The licensee shall fix an amount to be known as the minimum income and persons resident in Nigeria other than those in the categories set in the next paragraph, who are desirous of membership of the club shall be admitted to such membership and to play subject to proof to the satisfaction of the licensee that any such applicant is in receipt of at least the minimum income in respect of any consecutive period of twelve months preceding the date of application for membership.
3. Persons of the following categories shall not while in the Federal territory be eligible for membership of the club, namely :—
  - (a) persons serving in the armed forces of the Federation ;
  - (b) persons serving in the Nigeria Police Force or in any local government or native authority police force ;
  - (c) members (including presidents) of any court of law in the Federation ;
  - (d) officers of the public service of the Federation, or of any Region ;
  - (e) officers or servants of any local government council, native authority, or body corporate directly established by any law enacted by any legislature, in the Federation.



L.N. 110 of 1964

ELECTORAL ACT, 1962  
(1962, No. 31)

Public Service Commission of the Federation  
(Delegation of Powers) Notice, 1964

Commencement : 24th September, 1964

In exercise of the powers conferred by section 147 of the Constitution of the Federation, and of all other powers enabling it in that behalf, the Public Service Commission of the Federation, with the approval of the Prime Minister, has made the following Delegation Notice—

1. This Notice may be cited as the Public Service Commission of the Federation (Delegation of Powers) Notice, 1964. Citation.

2. The powers and duties of the Public Service Commission of the Federation under the sections of the Electoral Act, 1962 as shown in the Schedule hereto, are delegated to the Permanent Secretary, Federal Ministry of Internal Affairs, subject to the conditions that such powers shall be exercised and such duties performed in accordance with any general or special direction given by the Public Service Commission of the Federation. Delegation of powers.

SCHEDULE

Section 5 subsections (1) and (3)

Section 9

Section 29 subsection (1)

Section 30 subsection (1)

DATED at Lagos this 16th day of September, 1964.

SULE KATAGUM,  
*Chairman*

YUSUFU JEGA,  
*Commissioner*

L. O. UWECHIA,  
*Commissioner*

M. E. R. OKORODUDU,  
*Commissioner*

L.N. 111 of 1964

THE CONSTITUTION OF THE FEDERATION  
(1963, No. 20)

**The Supreme Court (Bench and Divisions) Rules, 1964**

*Commencement : 18th September, 1964*

In exercise of the powers conferred by section 121 of the Constitution of the Federation, the Supreme Court has made the following rules :—

1. These Rules may be cited as the Supreme Court (Bench and Divisions) Rules, 1964 and shall come into force on 18th September, 1964.

2. In these Rules, unless it is otherwise expressly provided or required by the context—

'Chief Justice' means the Chief Justice of Nigeria ;

'Judge' includes the Chief Justice and the Justices of the Supreme Court ;

'matter' includes an appeal and any cause or matter within the jurisdiction of the Supreme Court and anything covered by the word 'matter' in subsection (4) of section 121 of the Constitution of the Federation.

3. The Supreme Court may, according as the Chief Justice from time to time may direct, sit as one bench only or in two or three divisions sitting at the same time.

4. Where in any matter an important point of law arises which the Chief Justice (whether or not a member of the bench which took the matter) thinks should be considered by a larger bench, he may direct the matter to be heard or reheard before a larger bench, which shall include, if the matter was heard in part or in full, the judges who had heard the matter or as many of them as can be had : provided that no such direction shall be given after judgment on the matter has been delivered.

MADE at Lagos this 16th day of September, 1964.

A. A. ADEMOLA,  
Chief Justice of Nigeria

L.N. 112 of 1964

THE CONSTITUTION OF THE FEDERATION  
(1963, No. 20)

Adaptation of Laws (Miscellaneous Provisions) Order, 1964

Commencement : 1st October, 1963

In exercise of the powers conferred upon him by section one hundred and fifty-six of the Constitution of the Federation the President acting in accordance with the advice of the Council of Ministers hereby makes the following Order—

1. The Acts referred to in the First Schedule to this Order (being Acts having effect by virtue of the said Constitution in whole or in part throughout the Federation) are hereby modified to the extent specified under the respective short titles thereof.

General modifications in statutes applicable mainly to the Federation.

2. The Acts referred to in the Second Schedule to this Order (being Acts which by virtue as aforesaid may be amended only in so far as they have effect in the Federal territory unless otherwise therein set out) are hereby modified to the extent specified under the respective short titles thereof.

General modifications in statutes applicable mainly to the Federal territory.

3. Except where otherwise expressly provided, if by this Order sections are to be added, or words substituted for certain other words in any section or portion of an existing enactment, or words are to be omitted or remain unmodified therein that addition, substitution or omission shall, as the case may require be made, or the words shall remain unmodified accordingly.

Substitution etc. recurrent in enactment.

4. If as a consequence of any modification effected by this Order a Minister is authorised to appoint any person to exercise any functions under the Act so modified, and such person is an officer in the public service of the Federation, the consent of the relevant authority controlling the particular service shall be necessary to such appointment; but a statement in the terms of any appointment that such consent has been given shall be *prima facie* evidence of such consent.

Appointment of member of Federal Public Service to exercise functions.

5.—(1) The provisions of this Order which adapt or modify any existing law so as to alter the manner in which or the authority by which or the law under or in accordance with which any powers are exercisable, shall not render invalid any notification, order, by-law, rule, regulation, or delegation duly made or issued, or anything done before the commencement of this Order. Any such notification, order, by-law, rule, regulation, or delegation may be revoked, varied or undone in the like manner, to the like extent and in the like circumstances as if it had been made, issued or done after the commencement of this Order by the competent authority, and under and in accordance with the provisions then applicable to such case.

Savings.

(2) Nothing in this Order shall affect the previous operation of or shall affect anything duly done, or suffered under any existing instrument, or any right, privilege, operation or liability already acquired, accrued or incurred under any law, or any penalty, forfeiture or punishment incurred in respect of any offence already committed against an existing law.

Short title,  
application,  
etc.

6.—(1) This Order may be cited as the Adaptation of Laws (Miscellaneous Provisions) Order 1964.

(2) The modifications and adaptations herein shall, in respect of every Act in the Schedules hereto, apply according as a section or other division intended to be hereby affected, applies to the Federation, or to the Federal territory.

## FIRST SCHEDULE

### ADMINISTRATION (FOREIGN EMPLOYMENT) ACT (CAP. 1)

#### Section 4

*Delete* "Governor-General" and *substitute* "Public Service Commission of the Federation".

#### Section 5

*Delete* "Every" and *substitute* "Any person exercising the powers of a".

### ADMINISTRATION OF ESTATES BY CONSULAR OFFICERS ACT (CAP. 3)

#### Section 3

*Delete* "Governor-General" and *substitute* "President"

*Delete* "Her Majesty" in paragraph (b) and *substitute* "the Government of the Federation".

### ADMINISTRATOR-GENERAL'S ACT (CAP. 4)

#### Section 2

In the definition of "High Court" *delete* the words of interpretation and *substitute* "the High Court of a territory".

#### Section 3

In subsection (1) *delete* "Governor" and *substitute* "Public Service Commission of the Federation".

#### Section 50

*Delete* subsections (3) and (5).

In subsection (4) *delete* "Governor-General" and *substitute* "Minister".

#### Section 53

*Delete* "Governor-General" and *substitute* "Minister".

#### Section 67

*Delete* "the divisional officer of the division" and *substitute* "the Minister or other authority exercising the powers of a divisional officer of the division in the region".

#### Section 70

In subsection (3) *delete* "1894" and *substitute* "1962" and *delete* the corresponding marginal note.

#### Section 74

*Delete* this section.

ADMIRALTY TRANSPORTS (DISCIPLINE) ACT (CAP. 5)  
(See under NAVY TRANSPORTS (DISCIPLINE) ACT)

ADULTERATION OF PRODUCE ACT (CAP. 6)

**Section 3**

Delete "The Governor-General may appoint" and substitute "There may appointed by the proper authority".

**Section 5**

In subsection (2) delete "Governor-General in Council" and substitute "Minister".

**Section 14**

Delete "Governor-General in Council" and substitute "President".

AIR NAVIGATION (SAFETY OF NAVIGATION) ACT  
(CAP. 8)

**Section 2**

In the definition of "Aerodrome" delete "or of Her Majesty's Air Force".

**Section 13**

In subsection (1) delete "or of the Southern Cameroons".

**Section 17**

Delete "Governor-General" and substitute "President".

ANTIQUITIES ACT (CAP. 12)

**Section 2**

In the definition of—

(a) "antiquity" delete "Governor-General" where it occurs and substitute "President";

(b) "the Minister" delete "by directions given under section 98 of the Nigeria (Constitution) Order in Council 1954".

**Section 4**

Delete except as to the marginal note and substitute—

"4.—(1) The Commission shall consist of a chairman and a deputy chairman both to be appointed by the Minister and such other members as may be appointed under subsection (2) of this section.

(2) The other members to be appointed shall comprise—

(a) three persons appointed by the Minister,

(b) four persons from each Region appointed by the respective Governors."

**Sections 9 (1), 14, 16, 17, 20, 26 (1)**

Delete references to "Governor-General" or "Governor-General in Council" wherever they occur and substitute "Minister".

**Sections 16, 26 (2)**

Delete references to "in Council" where they occur relative to a Governor of a Region.

AUDIT ACT (CAP. 17)

In the long title and in sections 3, 4, 5, 7, 8, 9, 10, 11, 12, 13, 14, 15.

Delete "of Federal Audit" where it occurs and substitute "of Audit of the Federation".

**Section 2**

Delete the definition of Director-General of the Oversea Audit Service.

**Section 3**

In subsection (1) *delete* the first sentence and *substitute* "There shall be appointed under the Constitution of the Federation a fit person to hold the office of Director of Audit of the Federation who shall not, while holding such office, be capable of holding any other office of profit under the State."

**Section 5**

*Delete* "the Governor-General shall appoint a" and *substitute* "there may be appointed a fit"

**Section 6**

*Delete* this section except as to the marginal note and *substitute*—  
"6. If the office of Director of Audit of the Federation is vacant or the holder of the office is for any reason unable to perform the functions of the office some other person may, subject to the provisions of the Constitution of the Federation, be appointed to act in the office."

**Section 7**

In subsection (1) *delete* "under the general supervision of the Director-General of the Oversea Audit Service"

**Section 9**

In subsection (1) *delete* from "shall audit" up to the end of the subsection and *substitute* "may, if he thinks fit, audit the accounts of any body established by any Act."

In subsection (4) *delete* "Governor-General in Council" and *substitute* "Minister"

**Section 11**

*Delete* "Governor-General" and *substitute* "President"

**Section 13**

In subsection (1) *delete* "Governor-General in Council" and *substitute* "Minister"

**Section 15**

*Delete* this section

**BANKING ACT (CAP. 19)****Section 3**

In paragraph (a) of subsection (5) *delete* "Governor-General in Council" and *substitute* "President"

**Section 14**

In paragraph (c) *delete* "Governor-General in Council" and *substitute* "President"

**BUILDING LINES (FEDERAL TRUNK ROADS) ACT (CAP. 27)****Section 2**

In the definition of "Federal trunk road" *delete* all words after "road" where it last occurs up to the end of the definition and *substitute* "under the Constitution of the Federation for the purposes of its construction, alteration and maintenance ;"

**CARRIAGE OF GOODS BY SEA ACT (CAP. 29)****Section 1**

In subsection (2) *delete* from the commencement up to "1894" and *substitute* "Nothing in this Act shall affect the operation of sections two hundred and forty-seven, two hundred and forty-eight, two hundred and forty-nine, two hundred and fifty-two, three hundred and eighty-two, and three hundred and eighty-three of the Merchant Shipping Act 1962,"

**CENTRAL BANK OF NIGERIA ACT (CAP. 30)****Section 2**

In the definition of "Region" or "Regional" *delete* the words "or to the southern Cameroons"

**Section 4**

In subsection (1) *delete* "Federal Government" and *substitute* "Government of the Federation"

*Delete* subsection (2) (as inserted by the Adaptation of Laws (Cameroons Provisions) Order 1960)

**Section 9**

In subsection (1) *delete* "Governor-General" and *substitute* "President"

**Section 11**

In paragraph (a) of subsection (2) *delete* "Governor-General" and *substitute* "President"

In paragraph (b) of subsection (2) *delete* "Governor-General" and *substitute* "Prime Minister"

## CHANGE OF TITLES ACT (CAP. 31)

**Section 4**

*Delete* from "Governor-General in Council" up to the word "Cameroons" and *substitute* "Minister charged with responsibility for the ministry, department or office affected"

**Section 6**

*Delete* from "Governor-General in Council" up to the word "Cameroons" and *substitute* "Minister charged with responsibility for the department affected"

## CIVIL AVIATION (BIRTHS, DEATHS AND MISSING PERSONS) ACT (CAP. 33)

**Section 2**

In the definition of "principal Registrar" *delete* all words after "appointed" up to the end of the definition and *substitute* "under the Births, Deaths and Burials Act."

## COINS ACT (CAP. 34)

**Section 3**

In subsection (1) *delete* the words "Subject to the approval of the Secretary of State,"

**Section 8**

In paragraph (a) *delete* all words after "Region" up to the end of the paragraph.

## COMPANIES ACT (CAP. 37)

**Section 2**

In the definition of "prescribed" *delete* "Governor-General" and *substitute* "President"

**Section 223**

In subsection (1) *delete* all words after "elsewhere" up to the end of the subsection and *substitute* "in accordance with the relevant provisions of the Oaths Act 1963"

## CONSULAR CONVENTIONS ACT (CAP. 38)

**Section 4**

In subsection (1)—

(a) *delete* "this section" and *substitute* "any Act conferring diplomatic immunity or privilege";

(b) *delete* "Secretary" and *substitute* "Minister"

In subsection (2) *delete* "the United Kingdom and Colonies" and *substitute* "Nigeria"

**Section 5**

*Delete* "Governor-General" and *substitute* "Federal Minister charged with responsibility for External Affairs"

**Section 6**

In subsection (1)—

(a) *delete* "Governor-General in Council" and *substitute* "Federal Minister charged with responsibility for Finance",

(b) *delete* "Her Majesty" and *substitute* "or on behalf of Nigeria"

In subsection (3)—

(a) *delete* from paragraph (b) "or the Southern Cameroons",

(b) *delete* from paragraph (c)—

(i) "or the Southern Cameroons" where it twice occurs, and

(ii) "or the Commissioner of the Cameroons, as the case may be,"

COPYRIGHT ACT (CAP. 40)

**Section 2**

(a) in paragraph (a) *delete* "Comptroller of Customs and Excise" and *substitute* "Board of Customs and Excise";

(b) in paragraph (b),—

(i) *delete* "Comptroller" and *substitute* "said Board", and

(ii) *delete* "Governor-General in Council" and *substitute* "President";

(c) in paragraph (c) *delete* "Comptroller" where it twice occurs and *substitute* "said Board";

(d) in paragraph (d) *delete* "Customs Act" and *substitute* "Customs and Excise Management Act, 1958".

CRIMINAL CODE ACT  
(CAP. 42)

**Section 2**

In subsection (1) *delete* all words following "Region" where it first occurs up to the end of the subsection and *substitute* "and of the Federal territory with respect to the several matters therein dealt with, and shall apply as though the Federal territory were a Region"

In subsection (2) *delete* the word "first"

**Section 3**

*Delete* "in Council" where it occurs therein

CRIMINAL CODE  
(As the schedule to the Criminal Code Act)

**Section 1**

In subsection (1)—

In the definition of "court" in paragraph (d) *delete* "Federal Supreme Court and the judges" and *substitute* "Supreme Court and the Justices"

In the definition of "judicial officer" *delete* "and a judge of the Federal" and *substitute* "and a justice of the"

*Delete* the definition of "law officer" and *substitute*—

"Law Officer" in respect of the Federation or for the purposes of the Federal territory means the Attorney-General and the Solicitor-General of the Federation respectively, and includes the Director of Public Prosecutions and such other qualified officers, by whatever names designated, to whom any of the powers of a law officer are delegated by law or necessary intendment;

In the definition of "mail" *insert* immediately before the words "Her Majesty" the words "the Federation or of"

*Delete* the definition of "Nigeria" and *substitute*—

"Nigeria" means the Federal Republic of Nigeria;

In the definition of "officer of the Posts and Telegraphs Department" *delete* "Governor-General" and *substitute* "Public Service Commission of the Federation"

In the definition of "packet boat" *delete* the words "employed by or under the Post Office or Admiralty of the United Kingdom, as well as any vessel" and *substitute* "and includes any other vessel so"

In the definition of "person" and "owner" *delete* "Her Majesty" and *substitute* "the State"

In the definition of "person employed in the public service"—

(a) *delete* paragraph (1) and *substitute*—

"(1) any civil office, the power of appointing a person to which or removing a person from which is vested in the Public Service Commission, or any board; or"

(b) *delete* paragraph (2) and *substitute*—

"(2) any office to which a person is appointed by or under the Constitution of the Federation or any enactment; or"

(c) in that part of the definition commencing with the words "and the said term further includes" *delete* in paragraph (6) thereof the word "Governor-General" and *substitute* "President"

Subsection (1A) (as inserted by the Adaptation of Laws (Federal Provisions) Order, 1960)

*Delete* this subsection

Subsections (2) and (3)

*Delete* these subsections

#### Section 10A

In subsection (1) *delete* the definition of "law of a Region" in relation to—

(a) any Region other than the Northern Nigeria means any law enacted by the Legislature thereof or having effect by the Constitution of the Federation as if it were such a law;

(b) Northern Nigeria means any law so enacted or having such effect but subject to the provisions of the Penal Code (Northern Region)

(c) the Federal territory or Lagos means any Act (including this Code) having effect throughout the Federation or applicable to the Federal territory only and includes any Act expressed to apply to Lagos as if it were a Region;

No. 25 of  
1960

#### Section 15

*Delete* "military" and *substitute* "armed"

#### Section 19

*Delete*—

(a) "Her Majesty" and *substitute* "the State"

(b) "Governor" and *substitute* "Attorney-General"

#### Section 21

*Delete* all words after "affects" up to the end of the section and *substitute* "the prerogative of mercy where exercised in accordance with the Constitution of the Federation."

#### CHAPTER VI:

*Delete* all words after "Treason and" up to the end of this chapter heading and *substitute* "certain other Offences"

#### Section 37

In subsection (1) *delete* all words after "against" up to the end of the subsection and *substitute* "the State, in order to intimidate or overawe the President or the Governor of a Region, is guilty of treason, and is liable to the punishment of death."

In subsection (2) *delete* all words after "against" up to "subjects" and *substitute* "the State with intent to cause such levying of war as would be treason if committed by a citizen of Nigeria,"

*Add* a new subsection (3) as follows—

"(3) Nothing in this section prevents any act from being treason which is treason by any other enactment having the force of law in Nigeria."

### Section 39

In subsection (1) *delete* "Her Majesty's pleasure" and *substitute* "the pleasure of the President"

### Section 40

In paragraph (2) *delete* "Governor-General" and *substitute* "President"

### Section 41

*Delete* paragraphs (a), (b) and (c) and *substitute* new paragraphs (a) to (d) as follows—

"(a) to remove during his term of office otherwise than by constitutional means the President of the Federal Republic as Head of State of the Federation and Commander-in-Chief of the armed forces thereof; or

(b) to likewise remove during his term of office the Governor of a Region; or

(c) to levy war against Nigeria in order by force or constraint to compel the President to change his measures or counsels, or in order to put any force or constraint upon, or in order to intimidate or overawe any House of Parliament or any other Legislature or legislative authority; or

(d) to instigate any foreigner to make any armed invasion of Nigeria or of any of the territories thereof;"

### Section 44

In paragraph (a) *delete* all words after "serving" up to the end of the paragraph and *substitute* "in any of the armed forces of Nigeria or any member of the police force from his duty and allegiance; or"

### Section 45

*Delete* the words "non-commissioned officer or private of the military forces" and *substitute* "warrant or other officer below commissioned rank and others inferior in rank to them and by whatever name described in any of the armed forces"

*Delete* the words "non-commissioned officer or private of the said military forces" and *substitute* "warrant or other officer below commissioned rank and others inferior in rank to them and by whatever name described in any of the said armed forces,"

### Section 46A

In subsection (1) in paragraph (a) *delete* "Her Majesty's Forces" and *substitute* "the armed forces of Nigeria"

### Section 48

In paragraph (1) *delete* "Her Majesty" and *substitute* "Nigeria"

### Section 49A

In subsection (1)—

(a) *insert* immediately after "enemy" the words "in any war in which Nigeria may be engaged"

(b) *delete* "Her Majesty's forces" and *substitute* "the armed forces of Nigeria"

### Section 49B

In subsection (2) *delete* "British" and *substitute* "Nigerian"

**Section 49C**

*Delete paragraphs (a) and (b)*

In paragraph (c) *delete* all words after "Nigeria"

**Section 49D**

*Delete this section*

**Section 50**

In subsection (2)—

In paragraph (a) of the definition of "seditious intention" *delete* all words after "person" where it first occurs up to "Nigeria" where it first occurs and *substitute* "of the President or of the Governor of a Region or the Government of the Federation"

In paragraphs (b) and (c) of the said definition *delete* "Her Majesty's subjects or" where the expression occurs and *substitute* "the citizens or other"

In the sub-division of the said definition commencing "But an act."—

(a) in paragraph (i) *delete* all words after "to show that" up to the end of the paragraph and *substitute* "the President or the Governor of a Region as the case may be ; or", and

(b) in paragraph (iii) *delete* "Her Majesty's subjects or" and *substitute* "the citizens or other"

**Section 51**

*Delete* "Her Majesty" and *substitute* "the State" where the words occur in the section

**Section 55**

*Delete* "military" and *substitute* "armed"

**Section 57**

*Delete* "Governor-General" where it occurs in the section and *substitute* "President"

**Section 58**

In subsections (6), (7) and (8) *delete* "Her Majesty" where the expression occurs and *substitute* "the State"

In subsection (8) in paragraph (a) *delete* "in Council" where it twice occurs

**Section 61**

*Delete* "Governor-General" and *substitute* "President"

**Section 68**

*Delete* "Her Majesty" and *substitute* "the State"

**Section 72**

*Delete—*

(a) "Her Majesty's" and *substitute* "the"

(b) "in Nigeria" and *substitute* "of Nigeria"

(c) "Queen's name" and *substitute* "the name of the Federal Republic"

**Section 88**

In subsection (2) *delete* "Queen's name" and *substitute* "the name of the President"

**Section 109**

Delete "military" and substitute "armed"

**Section 110**

Delete in paragraph (1) the words "Her Majesty's naval or military forces or in the military forces" and substitute "any of the armed forces"; and delete where the words "Her Majesty or of the Governor-General" occur after the reference to an offence, and substitute "the President"

**Section 146**

Delete the definition of "current" and substitute—

"current" applied to coin, means any coin of the kinds or denominations coined for and lawfully current in Nigeria, and includes any other coin lawfully current in any other country;

**Section 148**

In subsection (3) in paragraph (e) delete "of Her Majesty's mints" and substitute "mint within the Commonwealth".

**Section 160A**

Delete this section and substitute

"Making etc. of promissory notes payable to bearer on demand without authority.

160A. Any person other than the Central Bank of Nigeria who makes or issues within Nigeria promissory notes payable to bearer on demand or circulates within Nigeria any promissory notes payable to bearer on demand is guilty of a misdemeanour and liable on conviction to a fine equal to double the value of every promissory note unlawfully made, issued or circulated or to imprisonment for a term of twelve months, or to both."

**Section 169**

Delete "Governor-General" and substitute "Minister charged with responsibility for postal matter"

**Section 171**

Delete "Governor-General" where it appears in the proviso and substitute "Minister charged with responsibility for postal matter"

**Section 177**

In paragraph (1)—

In sub-paragraphs (a) and (b) delete "Her Majesty's" where it occurs therein and substitute "State"

In paragraph (4) delete "Governor-General" and substitute "Minister charged with responsibility for postal matter"

**Sections 198, 202 and 203**

Delete "in Council" where it occurs

**Section 239**

In the proviso delete "the Eastern or Western Region or in Lagos or in the Southern Cameroons" and substitute "any Region (other than the Northern)

**Section 246**

Delete "Governor-General" and substitute "President"

**Section 251**

Delete "Her Majesty's naval or military forces or in the military" and substitute "any of the armed forces"

**Section 280**

Delete "military" and substitute "armed"

**Section 305**

In subsection (5) delete "or of the Region concerned"

**Section 319**

In subsection (2) delete "Her Majesty's pleasure" and substitute "pleasure of the President"

**Section 345**

In subsections (1) and (2) delete "British" and substitute "Nigerian" where the word occurs

**Section 350**

In the second paragraph delete all words after "property of" up to "military" and substitute "the State while it is under the control of an officer of the armed"

**Section 369**

In paragraph (6) delete "being a British subject or a non-native holds or possesses" and substitute "whether or not a citizen of Nigeria holds or possesses in Nigeria"

**Section 378**

In paragraphs (1) to (4) delete "Governor-General" where it occurs and substitute "President"

In paragraphs (2) to (4) delete "or a Secretary of State"

**Section 379**

In paragraph (1) delete "Governor-General, Minister, a Governor or a Secretary of State" and substitute "President or a Governor of a Region, or a Minister,"

In paragraph (2) delete "in Council"

**Section 390**

In paragraph (5) of the punishment in special cases provided by this section delete "Her Majesty" and substitute "the State"

**Section 428**

Delete "military" where it twice occurs and substitute "armed"

**Section 463**

In the definition of "bank note" delete "or West African"

**Section 467**

Under the heading "*Punishment in Special Cases*" in—

(a) paragraph (1) in sub-paragraph (a) delete all words after "used as," up to the end of the sub-paragraph and substitute "the public seal of Nigeria or of any Region of Nigeria or the great or privy seal of any country of the Commonwealth or under the protection of a Commonwealth country, or the seal of the President or the Governor of a Region; or"

(b) paragraph (2)—

(i) in sub-paragraph (a) delete all words after "debt" where it first occurs up to "State" and substitute "of Nigeria or of any Region thereof or of any other country"

(ii) in sub-paragraph (c) delete all words after "Government of any" where it secondly occurs and substitute "other country,"

(c) paragraph (3)—

(i) in sub-paragraph (a) delete all words after "signature of the" up to "State" where it secondly occurs and substitute "President or a Governor of a Region or of a Minister, as the case may be,"

i) in sub-paragraph (b) delete all words after "Nigeria" up to the end of the paragraph and substitute "or in any other country";

ii) in sub-paragraph (c) delete all words after "Nigeria" up to "Her Majesty" where it thirdly occurs and substitute "or any other property of State in any country,"

paragraph (4)—

i) in sub-paragraph (a) delete "Federal"

ii) in sub-paragraphs (a), (c) and (f) delete all words after "any part of" up to "Her Majesty" where they occur therein and substitute "a Commonwealth country or of a country under the protection of a Commonwealth country"

(iii) in sub-paragraphs (h) and (v) delete "in Council"

Section 470  
delete all words after "any part of" up to "Her Majesty" and substitute "a Commonwealth country or any country under the protection of a Commonwealth country"

Section 480

paragraph (1)—

i) in sub-paragraph (a) delete "of Her Majesty's dominions" and substitute "Commonwealth country or any country under the protection of a Commonwealth country";

b) in sub-paragraph (b) delete all words after "any part of" where it secondly occurs up to "Her Majesty" and substitute "a Commonwealth country or any country under the protection of a Commonwealth country";

c) in the reference to forfeiture at the end of this section delete "Her Majesty" and substitute "this State"

Section 481

paragraph (1) delete all words after "Nigeria or" up to "foreign country" and substitute "in any other country,"

Section 483

in paragraph (1) delete all words after "Nigeria or" up to "foreign country" and substitute "of any other";

In the reference to forfeiture in this section delete "Her Majesty" and substitute "the State"

Section 494

subsection (3) delete "Crown or the Government" and substitute "State of Lagos, the government of the State, as the case may be,"

Section 500

after "crew" a new definition as follows—

"Government" means the government of the Federation and includes a national government;

Section 505

immediately before the definition of "ship" a new definition as

"Government" means the government of the Federation and includes a national government;

Section 518

paragraph (1) delete "in Council"

Section 518A

subsection (1) delete "or the sovereign"

## CRIMINAL PROCEDURE ACT (CAP. 43)

**Section 1**

In subsection (2)—

(a) *delete* paragraph (a)

(b) in paragraph (b) *delete* all words after "Lagos" up to the end of the paragraph and *substitute* "as if it were a Region".

**Section 2**

In the definition of—

(a) "High Court" *delete* all words after "established" up to the end of the definition and *substitute* "for a Region",

(b) "offence" *delete* all words after the word "against" where it first force in the Region",

(c) "whip" *delete* "Governor-General" and *substitute* "Minister charged with responsibility for prisons"

*Insert* in alphabetical sequence the following definition—

"law officer" has the meaning assigned thereto under the Criminal Code ;

**Section 10**

In subsection (1)—

(a) in paragraph (e) *delete* all words after "deserter" up to the end of the paragraph and *substitute* "from any of the armed forces of Nigeria"

(b) in paragraph (f) *delete* all words after "he is" up to "extending to" and *substitute* "under any enactment in force in"

**Section 58**

In subsection (1)—

(a) *delete* "who is not a subject of Her Majesty or a native" and *substitute* "other than a citizen",

(b) *delete* "Governor-General" and *substitute* "Attorney-General of the Federation"

In subsection (2) in paragraph (b) *delete* "Governor-General" where it twice occurs and *substitute* "Attorney-General of the Federation"

**PART X**

In this division *delete* from the heading the word "CROWN" and *substitute* "STATE"

**Section 72**

In subsection (1) *delete* "Her Majesty's" and *substitute* "the"

**Section 73**

In subsection (1) *delete* "Crown" and *substitute* "State"

**Section 74**

In subsections (1) and (2) *delete* "Crown" where it occurs and *substitute* "State".

**Sections 131 and 132(1)**

*Delete* "crown counsel" or "or crown counsel" where the words appear

**Section 142**

*Delete* "Federal"

**Section 146**

In paragraphs (c), (e) and (f) *delete* "Crown" where it occurs and *substitute* "State"

**Section 213**

In subsection (1) *delete* "Crown" and *substitute* "State"

**Section 223**

In subsection (5) *delete* "or crown counsel"

on 230

subsection (2) *delete* "Her Majesty's pleasure" and *substitute* "the  
re of the President"

on 243A

subsection (1) *delete* from the commencement up to "that order the"  
*substitute* "Where any question as the interpretation of the Constitution  
Federation arises in the course of a trial and is referred to the Supreme  
under the provisions of the said Constitution that"

on 255

subsection (5) *delete* "Crown" and *substitute* "State"

ion 259

*delete* the word "Federal"

ion 272

paragraph (b) *delete* "Governor-General" and *substitute* "Federal  
ster of Finance"

ion 275

subsection (1) in paragraph (a) in subparagraph (i) *delete* "crown  
isel"

ion 292

*delete* "crown counsel or Resident"

tion 330

*delete* "Regional Attorney-General, crown counsel or Resident" and  
*substitute* "or to the Director of Public Prosecutions or a state counsel"  
the sub-heading immediately before section 333 *delete* "Crown" and  
*substitute* "State"

tion 333

n subsections (1), (2), (3) and (5) *delete* the words "or crown counsel"  
re they occur

tion 337

2) *Delete* "The Queen" where it first occurs and *substitute* "The Republic"

5) *Delete* "Our Lady the Queen" and *substitute* "The Republic"

3) *Delete* "[or A.B.] on behalf of our Lady the Queen" and *substitute*  
the Federation [or A.B.] on behalf of the Republic"

ctions 341 (1) and 342 (paragraph) (a)

*delete* "or crown counsel"

ion 343

*Delete* "crown counsel"

*Add* after "information" where it occurs at the end of the section,  
nothing in this section shall be construed so as to exclude the provisions  
ction 104 of the Constitution of the Federation."

on 349

the second proviso to subsection (1) *delete* "Crown" and *substitute*  
e"

on 352

*delete* "Crown" and *substitute* "State"  
"crown counsel"

n 363

*delete* "Her Majesty's" and *substitute* "the"

n 364

subsection (1) *delete* "Crown" and *substitute* "Republic"

n 368

subsection (3) *delete* "Her Majesty's pleasure" and *substitute* "the  
of the President"

**Section 370**

In subsection (1) *insert* after the word "authority" the words "mentioned in section 103 of the Constitution of the Federation"

*Delete* subsection (2) (as amended by the Criminal Procedure (Capital Sentences) (Amendment) Act 1961)

**Section 371A** (As inserted by section 3 of the Criminal Procedure (Capital Sentences) (Amendment) Act 1961)

*Delete* "Governor-General" and *substitute* "President"

**Section 371D** (As inserted by section 3 of the 1961 Act aforesaid)

*Delete* "Governor-General" and *substitute* "President"

**Section 376**

In subsection (4) *delete* "Federal"

Immediately before section 401, in the heading in italics and in "Part XLIV" *delete* "Her Majesty's Pleasure" and *substitute* "the pleasure of the President"

**Section 401**

In subsections (1) and (2) *delete* "Her Majesty's pleasure" and *substitute* "the pleasure of the President"

In subsections (1) to (4) *delete* "Governor" and *substitute* "President" where the word occurs

**Section 406**

*Delete* "Her Majesty" and *substitute* "the Federal Republic"

**Section 462**

*Delete* "Crown" and *substitute* "State"

In Chapter XII

In the reference to "Part III" *delete* "The Southern Cameroons"

**Section 486A** (as inserted by the Adaptation of Laws (Cameroons Provisions) Order 1960)

*Delete* this section

**Section 488** (as inserted by the Adaptation of Laws (Federal Provisions) Order 1960)

*Delete* this section

## FOURTH SCHEDULE—

The forms hereunder shall, for the purposes of section one hundred and one of the Constitution of the Federation have effect and be deemed to have been substituted for the forms in this Schedule which, in terms of section four of the Criminal Procedure (Capital Sentences) (Amendment) Act, 1961, were therein declared to have ceased to apply, that is to say—

PUBLIC  
SEAL

## ORDER FOR EXECUTION

WHEREAS at the  
holden at Lagos on the.....day of.....19....., one  
.....was duly convicted  
of a capital offence and was sentenced to death :

AND WHEREAS a written report of the case from the trial judge, together with such other information derived from the record of the case or elsewhere, having been duly taken into consideration at a meeting of the Advisory

Council the member of the Council of Ministers designated for the purpose in his own deliberate judgment thereafter has decided to recommend to me that I should exercise my powers in relation to the person so convicted :

AND WHEREAS I have decided in accordance with the advice of the said member of the Council of Ministers to confirm the sentence :

Now THEREFORE I do hereby order that the said sentence be carried out according to the law and that the said ..... be executed at a time and by the person appointed by you and that the body of the said..... be buried in the usual place for interment for condemned criminals executed at the place of execution.

AND FOR SO DOING this shall be your Warrant.

GIVEN under my hand and the Public Seal of the Federation this ..... 19..... day of .....

President

to the Sheriff at Lagos  
PUBLIC SEAL

ORDER FOR COMMUTATION OF SENTENCE

..... day of ..... 19.....

..... holden at Lagos :

..... convicted of a capital offence and was sentenced to death by the ..... holden at Lagos :  
..... written report of the case from the trial judge, together  
..... information derived from the record of the case or elsewhere  
..... taken into consideration at a meeting of the Advisory  
..... of the Council of Ministers designated for the purpose  
..... thereafter has decided to recommend to me  
..... in relation to the person so duly convicted :  
..... in accordance with the advice of the said  
..... to commute the sentence :  
..... commute the sentence and direct that the  
..... and that in lieu thereof the said  
..... be imprisoned for .....  
..... Public Seal of the Federation this  
..... day of ..... 19.....

President

(appropriate prisons authority)

## CROWN LANDS ACT (CAP. 45)

Long Title

Delete "Crown" and substitute "State"

Section 1

Delete "Crown" and substitute "State"

Section 2

Delete the definition of "Crown land" and substitute the following—

"State land" means all public lands in the Federation which are for the time being vested in the President on behalf or for the benefit of the Federal Republic or the Federal Government as the case may be, and all lands heretofore held or hereafter acquired by any authority of the Federation for any public purpose or otherwise for such benefit, as well as land so acquired under any Act of Parliament, but does not include lands which although acquired and so held are subject to the Land and Native Rights Act."

Section 3

Delete "consent of the Secretary of State" and substitute "approval of the Council of Ministers"

Sections 3, 4, 6 (1), 11, 13, 15, 18, 19, 26, 27, 28 (1), 29 (1), 30, 31, 33, 36, 38 (2)

Delete "Crown" where it occurs and substitute "State"

Sections 11 and 16

Delete "Her Majesty" and substitute "the State"

Section 22

Delete "Crown" where it occurs in subsections (2) and (3) and substitute "State"

Section 37

(a) Delete "Governor in Council" and substitute "Minister", and

(b) Delete "Crown" where it severally occurs and substitute "State"

Section 38

(a) Delete subsection (1) and substitute a new subsection as follows—

"(1) This Act shall apply to and in respect of Lagos as though it were a Region."

(b) Delete subsection (4)

## CURRENCY OFFENCES ACT (CAP. 46)

Section 2

In the definition of—

"coin" delete all words after "Nigeria" up to the end of the definition;

"note" delete all words after "enactment" up to the end of the definition.

Section 7

In subsection (1) delete the words "the Colony or Protectorate" and substitute "Nigeria"

## CUSTOMS DUTIES (DUMPED AND SUBSIDIZED GOODS) ACT (CAP. 47)

Sections 3 (1), 4, 5 (1), 6, 10 (4), 11

Delete "Governor-General in Council" where it occurs in the sections and substitute "President"

Section 5

In subsection (6) delete "Crown" and substitute "Federal Government"

alphabetical sequence the following definition—  
unless the context otherwise requires includes

ained in any” up to “Federal Legislature or”  
r in any proclamation or speech of the President  
any legislation of the United Kingdom still  
n any proclamation or speech”  
and *substitute* “part of the Commonwealth”

“Governor-General” and *substitute* “Federal

d *substitute* “the assumption of office of the  
sed by the President ; ”

l words after “Nigeria” where it first occurs up  
*substitute* “ ; the seals”

British Crown” and *substitute* “Nigeria”

er “territories” the words “within the Common-

ritish Crown” and *substitute* “Federal Republic”

ll words after “England” up to “Nigeria” and  
urt of Nigeria, or former Supreme Court now  
f Lagos,”

Her Majesty’s” and *substitute* “the”

on” up to “authorised” and *substitute* “in the

ragraph (iii) *delete* all words after “Nigeria”  
raph and *insert* “or elsewhere ;”

words “all proclamations, Acts” and *substitute*  
s of a Regional Legislature, proclamations,

nnement *insert* “Acts of Parliament of the  
utes theretofore enacted including”

on” and *substitute* “other part of the Common-

and *substitute* “any such country”

In paragraph (g) *delete* "British possession or of any foreign state" and *substitute* "other country"

In paragraph (i) —

(a) *delete* "any foreign court, in any British possession" and *substitute* "outside Nigeria,"

(b) in sub-paragraph (i) *delete* "the foreign" and *substitute* "a foreign"

(c) in sub-paragraph (ii) *delete* "Her Majesty" and *substitute* "Nigeria or if there is no such representative appointed then by any representative of the United Kingdom,"

In paragraph (j) *delete* "in the United Kingdom or in any British possession or in a foreign country" and *substitute* "elsewhere than in Nigeria"

### Section 115

*Delete* "British possession" and *substitute* "part of the Commonwealth"  
*Delete* all words after "journal" up to "Printer,"

### Section 116

(a) *delete* "the United Kingdom" where it occurs elsewhere than at the end of the section, and *substitute* "any part of the Commonwealth," and

(b) *delete* "the United Kingdom" where it occurs at the end of the section and *substitute* "the part of the Commonwealth where the document is produced"

### Section 117

*Insert* after the word "representative" the words "of Nigeria, or as the case may be,"

### Section 175

In paragraph (b) *delete* "Crown" and *substitute* "State"

**Section 230** (as inserted by the Adaptation of Laws (Cameroons Provisions) Order 1960)

*Delete* "and Southern Cameroons"

## FACTORIES ACT (CAP. 66)

### Section 3

*Delete* "Crown" and *substitute* "State"

### Section 4

*Delete* "Governor-General in Council" and *substitute* "President"

### Section 5

In subsection (7) *delete* "Crown" and *substitute* "State"

### Section 6

In subsection (1) in the definition of "Minister" *delete* all words after "Ministers" up to "1954" and *substitute* "charged with responsibility for the welfare of labour"

### Section 11

In subsection (2) *delete* all words after "Board" up to "if he thinks fit," and *substitute* "he may"

### Section 69

*Delete* subsection (1) and *substitute* the following new subsection—

"(1) There may be appointed for the purposes of this Act a chief inspector and such inspectors and other officers as may from time to time be necessary."

**Section 72**

In subsection (1) *delete* "the House of Representatives" and *substitute* "both Legislative Houses"

In subsection (2)—

(a) *delete* "The House of Representatives" and *substitute* "The Legislative Houses"

(b) *delete* "before the House"

FEDERAL LOANS BOARD ACT (CAP. 88)  
(Formerly Industrial Loans (Lagos and Federation) Act)

**Section 1**

*Delete* "1961"

**Section 2**

*Delete* all words after "charged" up to "1954".

**Section 4**

In subsection (2) *delete* all words after "consent of the" up to the end of the subsection and *substitute* "appropriate authority."

In subsection (3) *delete* in the proviso "Governor-General in Council" and "Crown" and *substitute* respectively "Minister" and "State".

**Section 5**

*Delete* in the proviso "Governor-General in Council" and *substitute* "appropriate authority"

**Section 9**

In subsection (1) in paragraph (c) of the proviso, *delete* "Governor-General in Council" and *substitute* "President".

**Section 23**

Re-number this as subsection (1) and *add* a new subsection as follows—

"(2) For the avoidance of doubt, the provisions of this section shall apply to any other Act providing for the registration of land in the Federal territory in replacement of the aforesaid Acts or either of them."

FIREARMS ACT (CAP. 69)

**Section 1**

In subsection (2) *delete* all words after "Lagos" up to the end of the subsection and *substitute* "as if it were a Region"

**Section 5**

In subsection (2) *delete* all words after "or any part thereof," where it first occurs up to "or any part thereof," where it secondly occurs

**Section 18**

*Delete* all words after "designated" up to "1955," and *substitute* "as a customs airport under any enactment"

**Section 25**

*Delete* all words after "Region" up to "Cameroons" where it secondly occurs.

**Section 33**

*Delete* subsection (2) and *substitute* the following new subsection—

"(2) The Governor in Council of a Region may by regulations provide for the fees to be paid in respect of the licensing of personal firearms in the Region."

**Section 39**

Delete all words after "apply" up to "Federation" and substitute "to any member of or any person attached or lent to the armed forces of Nigeria"

**FOLDED WOVEN GOODS ACT (CAP. 70)**

Insert the following as a new section 1A immediately following section 1—  
 'Interpretation. 1A. In this Act, "Minister" means the Federal Minister charged with responsibility for Customs.'

**Sections 12, 13 and 16**

Delete "Governor-General" or "Governor-General in Council" as the case may require and substitute "Minister"

**FUGITIVE CRIMINALS SURRENDER ACT (CAP. 73)****Section 1**

Delete subsection (2)

**Section 2**

Renumber as subsection (1) and in the definition of "diplomatic representative of a foreign State" delete "Governor-General" and substitute "President"

Insert a new subsection as follows—

"(2) References in this Act to "the Protectorate" or to "the Colony" shall be read and construed respectively as references to the parts of the Federal Republic formerly known by those names, and references to "Governor-General" where they occur in this Act shall be read as references to the President."

**Section 4**

In paragraph (c) delete "Her Majesty's jurisdiction" and substitute "the jurisdiction exercisable by or on behalf of the Crown in the United Kingdom"

**Section 5**

Delete "of Her Majesty's dominions or of the Protectorate" and substitute "in Nigeria"

**Section 16**

Delete "Her Majesty's dominions or protectorates" and substitute "Nigeria"

**GENERAL LOAN AND STOCK ACT (CAP. 74)****Section 3**

Delete "Governor-General" and substitute "Minister".

**Sections 5, 8, 13 and 14.**

Delete the word "Colony" where it occurs and substitute "Federation".

**Sections 16 and 29**

Delete "Secretary of State" where it occurs and substitute "Minister".

**Section 37**

Delete "with the approval of the Secretary of State".

**GOLD TRADING ACT (CAP. 76)****Section 1**

In subsections (2) and (3) delete all words after "Nigeria" up to "Trusteeship" where they occur in the subsections.

**Sections 13 and 17**

Delete "Mines Department" where it occurs and substitute "mines division of the ministry responsible for the control of minerals".

## LABOUR CODE ACT (CAP. 91)

### Section 3

Delete "Crown" and substitute "State"

### Section 4

In subsection (1) delete "The Governor-General may appoint" and substitute "There may be appointed"

### Section 5

In subsection (2) in paragraph (h) insert after "Minister" the words "and subject to the right of intervention of the appropriate Attorney-General"

### Section 66

In subsection (1) delete "other"

### Section 90

Delete "Governor-General in Council" and substitute "Minister"

### Section 91

Delete all words after "duties of the" up to the end of the section and substitute "Minister under this Part may be exercised by the Governor thereof."

### Sections 97, 112 and 117

Delete "Governor-General in Council" and substitute "President"

### Section 119

In subsection (2) in the definition of "prescribed" delete "Governor-General in Council" and substitute "in the case of a Region by the Governor thereof, and in the case of Lagos, by the Minister"

### Section 120

Delete "Governor-General" and substitute "President"

### Section 122

Delete "Governor-General in Council" and substitute "President"

### Section 159

Delete "or the Southern Cameroons"

### Section 177

Delete all words from the commencement up to "Minister" and substitute "The Minister may"

### Section 185

In subsection (1) delete "Imperial"

In subsection (2) delete all words after "Shipping Act," up to the end of the subsection, and substitute "1962, to make in respect of the maintenance and return of seaman to whom the provisions of subsection (2) of section forty-four of that Act are applicable."

### Section 188

In subsection (1) delete all words after "permitting" up to the end of the subsection and substitute "any person to embark at any port or place in Nigeria as a deck passenger, satisfies himself that such person, whether intending to work outside Nigeria or not, has complied with the requirements of the Immigration Act 1963, unless otherwise exempted therefrom."

Delete subsections (2) and (3)

**Section 190**

In subsection (1) *delete* all words after "generally by the" up to "natives of Nigeria;" in paragraph (a), and *substitute*—

"chairman of the Board of Customs and Excise—

(a) muster all his deck passengers who are citizens of Nigeria;"

In subsection (3) *delete* all words from the commencement of paragraph (a) up to "Protectorate," where it secondly occurs and *substitute*—

"(a) any person not otherwise exempted, who has embarked at any

port or place in Nigeria as a deck passenger, and whether or not intending to work outside Nigeria, has failed to comply with the requirements of the Immigration Act 1963; or

(b) any deck passenger who has embarked without proper entry papers for Nigeria at any port in West Africa outside Nigeria,"

1963 No. 6.

**Section 191**

*Delete* all words after "returning" up to "Protectorate" and *substitute* "any deck passenger found on muster made for the purposes of section one hundred and ninety of this Act to any other country"

**Section 192**

(a) *Insert* immediately after "regulations" the words "not inconsistent with the Immigration Act 1963"

(b) *Delete* paragraph (d)

**Section 194**

*Delete* "Her Majesty" and *substitute* "the Government of the Federation"

**Section 202**

*Delete* "with the approval of the Governor-General"

**Section 206**

In paragraph (c) *delete* "Her Majesty's Forces" and *substitute* "the Armed Forces of Nigeria;"

**Section 218**

*Delete* "Governor-General" and *substitute* "Federal Minister of Finance"

**Section 224**

In subsection (3)—

(a) in paragraph (a) *delete* "United Kingdom" and *substitute* "Commonwealth", and

(b) in paragraph (b) *delete* all words after "attached" up to the end of the paragraph, and *substitute* "or by any high commissioner, ambassador, consul, vice-consul, or consular agent of Nigeria."

**Section 226**

*Delete* "Governor-General in Council" and *substitute* "Minister"

**Section 228**

*Delete* all words after "Lagos" up to the end of the section and *substitute* "as if it were a Region"

**LAND AND NATIVE RIGHTS ACT (CAP. 96)**

In the long title *delete* all words after "within" up to the end thereof and *substitute* "Northern Nigeria and to make provision where rights are held for the purposes of the government of the Federation"

**Section 1**

(a) *Re-number* this as subsection (1); and *delete* all words therein after "apply," up to the end of the subsection and *substitute* "to Northern Nigeria, so however that the provisions of sections 7 and 13, to the extent of rights held for the purposes of the government of the Federation, shall have effect throughout the Federation."

(b) *Insert* a new subsection as follows—

"(2) To the extent to which reference is made in this Act to rights held for the purposes of the government of the Federation, nothing in this Act shall have effect in that part of the Cameroons formerly known as the Southern Cameroons, and this Act shall be so construed accordingly."

**Section 7**

(a) *Delete* "the Northern Region" and *substitute* "Northern Nigeria"

(b) *Delete* "Governor-General" where it twice occurs and *substitute* "President"

**Section 13**

In subsection (1) in paragraph (c) *delete* all words after "Federation" where it secondly appears up to the end of the paragraph

In subsection (2)—

(a) *delete* "the Northern Region" and *substitute* "Northern Nigeria"

(b) *delete* "Governor-General" and *substitute* "President"

LAW (MISCELLANEOUS PROVISIONS) ACT (CAP. 89)  
(Formerly Interpretation Act)

**Section 5**

*Delete* all words after "Region" where it first occurs up to the end of the section, and *substitute* "in such application references to the Attorney-General, the Director of Medical Services, the Director of Public Works and the Commissioner of Police of a Region shall mean respectively as to Lagos, the Attorney-General of the Federation, the Chief Medical Adviser to the Federal Government, the Chief Engineer in Lagos, and the Inspector-General of Police."

**Section 58**

*Delete* this section and *substitute*,—

58. Any document purporting to bear the fiat or consent of and to be signed by the Attorney-General of the Federation or any public officer duly designated by him and necessary before a prosecution or action as the case may be is commenced, shall be received by all courts and persons as prima facie evidence in any proceeding without proof of signature."

**Section 71**

*Delete* "Crown" and *substitute* "State"

LEGISLATIVE HOUSES (POWERS AND PRIVILEGES) ACT  
(CAP. 102)

**Section 2**

*Delete* the definition of "President" and *substitute* the following—

"President" in relation to the Senate means the President thereof and includes the Deputy President and any Senator for the time being presiding therein, and in relation to the House of Representatives means the Speaker and includes the Deputy Speaker and any Member for the time being presiding therein ;

**Section 8**

In subsection (2) *delete* "Governor-General" and *substitute* "President of the Federal Republic"

**Section 28**

*Delete* "Nigeria (Constitution) Order in Council 1954" and *substitute* "Constitution of the Federation"

**Section 29** (as substituted by the Adaptation of Laws (Miscellaneous Provisions) Order 1960)

*Delete* all words after "shall" up to the end of the section and *substitute* "as the case may require, forthwith thereafter give notice in writing of the fact to the President concerned."

**Section 30**

(a) *Insert* immediately after "him" the words "by the Constitution of the Federation or"

(b) *Delete* all words after "House" where it secondly occurs up to the end of the section

**Section 32**

*Delete* all words after "except" up to the end of the section and *substitute* "by the Attorney-General of the Federation upon information given to him in writing by the President of the House concerned."

## LOAN (INTERNAL BORROWING) ACT (CAP. 108)

**Section 3**

In paragraph (b) *delete*—

(a) "or to the Government of the Southern Cameroons",

(b) "or the Southern Cameroons" and

(c) where they thrice occur the words "or of the Southern Cameroons"

## LOCAL BORROWING ACT (CAP. 109)

**Section 5**

*Delete* all words after "as the case may be" up to the end of the section.

**Section 6**

*Delete* this section

## SCHEDULE

*Delete* "Southern Cameroons Marketing Board"

## LOCAL FORCES ACT (CAP. 110)

Immediately after section 62 *add* a new section as follows—

63. To the extent to which this Act is still in force, references therein—

(a) to units of the forces mentioned therein, shall be construed as references as nearly as may be to corresponding units of the Nigerian Army ;

(b) to "Governor-General" or "Governor-General in Council" shall be construed as references to the President ;

(c) to appointments, training, discipline and administration shall be construed as references to appointments, training, discipline and administration under or subject as nearly as may be to control by the Army Council ;

(d) to Her Majesty or Her Majesty acting through a Secretary of State shall be omitted."

LOCAL LOANS (REGISTERED STOCK AND SECURITIES)  
ACT (CAP. 111)

**Section 2**

In the definition of "Minister" *insert* immediately after the words "means the" the word "Federal"

**Section 3**

In subsection (1) *delete* "Governor-General" and *substitute* "Minister"

**Section 5**

In subsection 1A (as inserted by section 4 of the Local Loans (Registered Stock and Securities), (Amendment) Act 1959) *delete* the words "or of the Southern Cameroons" where they twice occur

**Section 46**

In subsection (2) *delete* "Federal Audit" and *substitute* "Audit of the Federation"

MANTENANCE ORDERS ACT (CAP. 114)

**Section 11**

*Delete* this section except as to the marginal note and *substitute*—

"11. Where the President is satisfied that reciprocal provisions have been made by the legislature of any country of the Commonwealth or of any British possession for the enforcement within such country or possession of maintenance orders made by courts in Nigeria, the President may by order extend this Act to such country or possession, and this Act shall thereupon apply in respect of such country or possession as though the references to England or Ireland were references to such country or possession and the references to the Secretary of State for the Colonies were references to the President, Governor-General, or Governor, as the case may be, of such country or possession."

**Section 13**

*Delete* all words after "Lagos" up to the end of the section and *substitute* "as if it were a Region"

MARRIAGE ACT (CAP. 115)

**Section 2**

*Delete* "Definitions" and *substitute* "In this Act unless the context otherwise requires"

*Insert* immediately after "district" a new definition as follows—

"Minister" means in respect of Lagos, the Federal Minister charged with responsibility for marriages, and includes in respect of a Region, the appropriate Minister ;

**Section 3**

*Delete* "Governor-General" and *substitute* "President"

**Section 4**

In subsection (1) *delete* from the commencement up to "appoint" and *substitute* "There may from time to time be appointed"

In subsection (2) *delete* "The Governor shall appoint" and *substitute* "There may likewise be appointed"

Subsection (3)

*Delete* this subsection

**Section 13**

*Delete* from the commencement up to "respectively," and *substitute* "The Minister"

**Section 15**

*Delete* "Federal"

**Section 20**

Delete paragraph (c) and substitute—

“(c) any officer of or above the grade of assistant secretary.”

**Section 35**

Delete “native law and custom” where it twice occurs and substitute “customary law”

**Section 36**

Delete “native law and custom” where it occurs in subsections (1) and (2) and substitute “customary law”

**Section 38**

(a) Delete “Governor” and substitute “Minister”

(b) Delete “Treasury” and substitute “Consolidated Revenue Fund or other appropriate Fund as the case may be,”

**Sections 47 and 48**

Delete “native law or custom” and substitute “customary law”

**Section 50**

(a) Delete “the Colony” and substitute “Nigeria”

(b) Delete “Governor-General” and substitute “Minister”

**Section 52**

(a) In paragraph (a) delete “the Colony” and substitute “Nigeria”

(b) In paragraph (d) delete “native law or custom” and substitute “customary law”

**Section 57**

Delete all words after “Lagos” up to the end of the section and substitute “as if it were a Region”

**FIRST SCHEDULE**

In Form D delete “Governor” and substitute “Minister”

In Form G delete “in the Colony”

In Form H delete “the Colony” and substitute “Nigeria”

**MERCHANDISE MARKS ACT (CAP. 117)****Section 14**

In subsection (3) delete “Governor-General in Council” and substitute “Minister”

**Section 18**

Delete all words after “holding a” up to “Royal Family” and substitute “warrant or other authority, or for the service of the President, or any ministry or department of the Federation,”

**MILITARY PENSIONS (CAP. 119)**

In the long title delete all words after “service” up to the end thereof and substitute “by Nigerian officers and other ranks in the military forces of Nigeria or by African officers and other ranks in any former military force”

**Section 2**

(a) Insert immediately after the definition of “lodging” a new definition as follows—

“Minister” means the Federal Minister charged with responsibility for military pensions;

(b) In the definition of “Military Forces of Nigeria” delete all words therein after “means” and substitute “the Nigerian Army”

(c) In the definition of “officer” delete “Her Majesty’s West African Forces” and substitute “the Nigerian Army”

**Sections 3 and 5**

Delete "Governor-General" where it occurs and substitute "Minister"

**Section 6**

In subsection (1) delete "Crown" and substitute "State"

In subsection (2) delete "Governor-General" and substitute "Minister"

**Section 7**

In subsection (1) in paragraph (d) delete "Governor-General" and substitute "Minister"

In subsection (2) (as substituted by section 2 of the Military Pensions (Amendment) Act 1958) in paragraph (a) delete "Governor-General" and substitute "Minister"

In subsection (3) in paragraph (b) delete "Governor-General" where it occurs and substitute "Minister"

In subsection (4) in paragraph (b) delete "Governor-General" and substitute "Minister"

**Section 8**

Delete "Governor-General" and substitute "Minister"

**Section 9**

Delete "Governor-General" and substitute "Federal Minister charged with responsibility for defence"

**Section 11**

Delete "Crown" where it twice occurs and substitute "State"

**Section 12**

In subsection (3) delete "Governor-General" where it occurs and substitute "Minister"

In subsection (5) delete "Governor-General" and substitute "Minister"

**Section 13**

Delete "Governor-General" where it occurs in subsections (1), (3) and (5) and substitute "Minister"

**Section 14** (as substituted by section 2 of the Military Pensions (Amendment) Act 1960)

Delete "Governor-General" where it occurs in subsections (1) and (3) and substitute "Minister"

**Section 15**

In subsection (1) delete "Governor-General" where it occurs and substitute "Minister"

**SCHEDULE**

In paragraph 3 in subparagraph (1) (b) delete "Governor-General" and substitute "commander of the Nigerian Army"

In paragraphs 6, 11 (3), 13 (1) proviso, 14 (first proviso) and 15 (4) delete "Governor-General" and substitute "Minister"

**MINERAL OILS ACT (CAP. 120)**

**Section 6**

In subsection (1) in paragraph (b) delete "Crown" and substitute "State"

**Section 9**

Delete "Governor-General in Council" and substitute "Minister"

## MINERALS ACT (CAP. 121)

**Section 2**

(a) In the definitions of "chief inspector" and "inspector" delete "Governor-General" and substitute "Public Service Commission of the Federation"

(b) In the definition of "owner"—

(i) delete in the reference therein to "native community" where it twice occurs the word "native", and

(ii) delete "native law and custom" and substitute "customary law"

(c) In the definition of "private land" delete "Crown" where it occurs and substitute "State"

**Section 3**

In subsection (1) delete "Crown" and substitute "State"

**Section 5**

In subsection (1) delete "native" and substitute "citizen"

**Section 18**

In subsection (7) delete "Crown" and substitute "State"

**Section 19**

In subsection (1) in proviso (iii) delete "Crown" and substitute "State"

**Section 21**

Delete "Crown" and substitute "State"

**Section 41**

In subsections (2) and (4) delete "Crown" and substitute "State"

In subsection (5) delete "Resident of the province" and substitute "Chief Inspector"

**Section 42**

Number the two paragraphs as subsections (1) and (2) respectively

**Section 43**

Delete "Crown" where it occurs in the subsections and substitute "State"

**Sections 45, 75(2) and 77**

Delete "Crown" and substitute "State"

**Section 81**

In subsection (1) delete from the commencement up to "consider" and substitute "There may from time to time be appointed a chief inspector and such other inspectors and officers as may be considered"

**Section 82**

In paragraph (c) delete "Crown" and substitute "State"

**Section 85**

In subsection (1),—

(i) in paragraph (a) delete—

(a) "Crown" and substitute "State"

(b) all words in the paragraph after "Region" up to the end of the paragraph;

(ii) in paragraph (b)—

(a) delete "this" and substitute "his",

(b) after "Governor" insert the words "of the Region or in the case of Lagos of the Minister";

(iii) in paragraph (c) in subparagraph (ii) delete "Governor-General" and substitute "Minister"

**Section 102**  
*Delete* "Governor-General" and *substitute* "Minister"

**Section 107**  
*Delete* "Crown" and *substitute* "State"

**Section 115**  
In paragraph (b) *delete*—  
(a) "native" and *substitute* "citizen of Nigeria",  
(b) "Governor-General" and *substitute* "Minister",

**Section 118**  
In subsection (1) *delete* "Governor-General in Council" and *substitute* "Minister"

In subsection (2) in paragraph (xxi) *delete* "Governor-General" and *substitute* "Minister"

**Section 120**  
In subsection (1)—  
*delete* "Department" where it first occurs and *substitute* "Division of the Ministry responsible for the control of minerals"  
*delete* "Department" where it secondly occurs and *substitute* "division"

#### FIRST SCHEDULE

In Form B *delete* "Governor-General" and *substitute* "Minister"

In Form I in paragraph 4 of the terms and conditions, *delete* "Crown" and *substitute* "State"

### MINISTERS' STATUTORY POWERS AND DUTIES (MISCELLANEOUS PROVISIONS) ACT (CAP. 122)

**Section 1**  
*Delete* the apostrophe in the word "Ministers" in the short title

**Section 2**  
In subsection (1) *delete*—  
(a) "Governor-General" where it first occurs and *substitute* "President",  
(b) "Governor-General in Council",  
(c) "(other than the Secretary of State)"

In subsection (3)—  
(i) *delete* in paragraph (a) all words after "for which" up to the end of the paragraph, and *substitute* "under the Constitution of the Federation, a Minister may not be charged with responsibility; or",  
(ii) *delete* in paragraph (b) "Federal Audit" and *substitute* "Audit of the Federation".

**Section 3**  
In subsection (1) in paragraph (c) *delete* "Governor-General" and *substitute* "Nigeria Police Council or of the Police Service Commission of the Federation, as the case may require,"

**Section 4**  
*Insert* at the end of the section "The signification of the exercise of the power shall be sufficient evidence that all necessary consents have been obtained, unless the contrary is proved."

**Section 5**

Delete all words after "of such power" up to "such Order" and substitute "made and in operation immediately before the twentieth day of January 1964 (being the date of the commencement of the Interpretation Act 1964) and notwithstanding the repeal of the authority under which the delegation was made,"

**MOTOR SPIRIT (RETURNS) ACT**  
(CAP. 125)

In the long title delete all words after "provision" up to "relating" and substitute "for making returns of motor spirit imported into Nigeria for purposes incidental"

In the second recital delete the words "Nigeria (Constitution) Order in Council, 1954" and substitute "Constitution of the Federation"

**Section 2**

In the definition of "prescribed authority" delete all words after "means" and substitute "the Board of Customs and Excise"

**Section 3**

In subsection (3) insert immediately following the word "authority" the words ", who shall for the purposes of this Act be the Board of Customs and Excise."

**Section 7**

In subsection (4) delete all words after "deposited in a" up to "Customs Act" and substitute "State, Government or private warehouse approved or licensed as the case may be under the Customs and Excise Management Act, 1958,"

**Section 11**

In subsection (4) delete "of the High Court"

**Section 15**

Delete "Customs Ordinance" and substitute "Customs and Excise Management Act, 1958"

**Section 17**

Delete all words after "Lagos" up to the end of the section and substitute "as if it were a Region"

**NAVY TRANSPORTS (DISCIPLINE) ACT (CAP. 5)**  
(Formerly Admiralty Transports (Discipline) Act)

Long Title and **Sections 1 and 2 (1)**

Delete "Admiralty" where it occurs and substitute "Navy"

**Section 2 (2)**

(a) Delete "221" and substitute "112"

(b) Delete "1894" where it twice occurs and substitute "1962"

**NIGER TRANSIT ACT**  
(CAP. 130)

**Section 4**

Delete "Governor-General in Council" and substitute "President"

**NIGERIA (TEN YEAR PLAN) LOCAL LOAN ACT**  
(CAP. 132)

**Section 3**

Delete all words after "Nigeria, as the" up to "State" and substitute "Minister with the approval of Parliament may,"

BROADCASTING CORPORATION ACT  
(CAP. 133)

Section two of the Nigerian Broadcasting Corporation Act (1962) (Cap. 133) (1)

Paragraph (iii)—  
Paragraph (a) delete "Foreign Affairs and Commonwealth External Affairs"  
"Governor-General in Council" and substitute

"as determined" up to "Crown" and substitute "by the State" and "no remuneration, fees or allowances, except such as may from time to time be authorised or approved by the Ministers, shall be paid to any person who holds office in the State."

"Governor-General in Council" and substitute

"Minister" in Council" and substitute "Minister"

Paragraphs (a) and (b) delete "Governor-General in Council" and substitute "President"

"Governor-General in Council" where it occurs in the proviso and in the Ministers"

Paragraph (a) delete "Governor-General in Council" and substitute

"Governor-General" and substitute

"Governor-General or the Governor of the Region" and substitute "Governor or Regional Minister"

"Governor-General in Council" and substitute "Council of Ministers"

Paragraph (3) delete "Governor-General" where it occurs

Paragraph (i) of paragraph (b)

"Governor-General in Council" where it occurs in the subsections

Proviso

COAL CORPORATION ACT  
(CAP. 134)

Proviso to subsection (4)—  
"Governor-General" and substitute

"the Council of Ministers", and substitute "State"

**Section 12**

In subsection (1) *delete* "Governor-General in Council" where it twice occurs and *substitute* "President"

In subsection (2) *delete* "Governor-General" and *substitute* "President"

**Section 17**

In subsection (2) *delete* "Resident" and *substitute* "Minister in a Region or in Lagos, as the case may be, charged with responsibility for matters of any such nature"

**Section 19**

In subsections (1) and (3) *delete* "Crown" where it occurs and *substitute* "State"

**Section 24**

*Delete* "Secretary of State" and *substitute* "Federal Minister of Finance"

**Section 26**

In subsection (4) *delete* "the House of Representatives" and *substitute* "both Federal Legislative Houses"

**Section 27**

In subsection (2) *delete* "the House of Representatives" and *substitute* "both Federal Legislative Houses"

**Section 31**

In subsections (5) and (6) *delete* "Governor-General" where it occurs and *substitute* "Public Service Commission of the Federation or of a Region, as the case may be,"

**Section 33**

*Delete* "Governor-General in Council" and *substitute* "Minister"

NIGERIAN RAILWAY CORPORATION ACT  
(CAP. 139)

**Section 5**

In paragraph (b) *delete* "twelve" and *substitute* "thirteen"

In paragraph (b) in subparagraph (iii)—

(a) *delete* "three" and *substitute* "four"

(b) *insert* at the end of the subparagraph "and one by the Governor in Council of the Mid-Western Region"

**Section 7**

*Delete*—

(a) "Governor-General in Council" and *substitute* "Council of Ministers"

(b) "Crown" and *substitute* "State"

**Section 17**

In subsection (1) in paragraph (f) *delete* "Governor-General in Council" and *substitute* "President of the Republic"

**Section 26**

In subsection (2) *delete* "Governor-General in Council" and *substitute* "Minister"

**Section 33**

In subsections (1), (2) and (3) *delete* "Governor-General" where it occurs and *substitute* "President"

**Section 40**

In subsection (7) *delete* "Crown" where it twice occurs and *substitute* "State"

In subsection (11) *delete* "Governor-General in Council" and *substitute* "Minister"

Sections (1) and (2) *delete* "Governor-General" where it occurs  
*substitute* "Public Service Commission of the Federation"

Section (1)—  
Paragraph (b) *delete* "the Queen's enemies" and *substitute* "of the  
of the State," and  
Paragraph (d) *delete* "or of the Southern Cameroons"

"Governor-General in Council" and *substitute* "Minister"

## NOTARIES PUBLIC ACT (CAP. 141)

Subsections (1) and (2) *delete* "the Federation" where it occurs and  
*substitute* "Nigeria"

"the Federation" where it twice occurs and *substitute* "Nigeria"

Subsection (1) *delete* "Federal"  
Subsection (2) *delete* "the Federation" and *substitute* "Nigeria"

Subsection (3) *delete* "the Federation" and *substitute* "Nigeria"

Sections 6, 7, 8, 9, 10 and 12  
*delete* "Federal" where it occurs

"the Federation" and *substitute* "Nigeria"

"judges" where it occurs in the subsections and *substitute* "justices"

Subsection (1) *delete* "the Federation" and *substitute* "Nigeria"

Subsection (1) *delete* all words after "notary public" where they first  
up to "Protectorate", and *substitute* "in that part of Nigeria formerly  
as the Colony may act as a notary public in any part of Nigeria and"  
Subsection (2) *delete* "Federal"

*delete* the word "Federal" where it secondly occurs

## OIL PIPELINES ACT (CAP. 145)

"the definition of "Minister" *delete* all words after "charged" up to

"Federal"

"Governor-General" and *substitute* "Minister"

"Lagos" up to the end of the section and *substitute*  
"were a Region"

PENSIONS ACT (CAP. 147)  
A—PENSIONS ACT

In the long title *delete* "Her Majesty's Service" and *substitute* "oversea service civil or military on behalf of the United Kingdom and known as Her Majesty's Service or, as the case may be, in Service of the State."

**Section 3**

In the paragraph to subsection (1) *delete* all words after "shall be" up to the end of the paragraph and *substitute* "published in the Gazette and laid before both Legislative Houses."

**Section 6**

In subsection (1) *delete* "Crown" and *substitute* "State"

**Section 17**

In subsection (4) *delete* "Her Majesty" and *substitute* "Nigeria"

FIRST SCHEDULE

Regulation 24

In paragraph (4) *delete* "Her Majesty" and *substitute* "Nigeria"

Regulation 30

*Re-number* this as paragraph (1) and *insert* a new paragraph as follows—

"(2) The Minister may by order in the Gazette apply the provisions of this regulation to the case of service with the armed forces of Nigeria and in such case any reference to "Her Majesty's Forces" shall be read as a reference to the armed forces of Nigeria."

Regulation 31

*Insert* after "active list" the words "of the armed forces of Nigeria or, as the case may be, of the"

PETITIONS OF RIGHT ACT (CAP. 149)

**Section 3**

*Delete* except for marginal note and *substitute*—

"3. All claims against the Government of the Federation or against any Ministry or Department thereof, being of the same nature as claims which before the commencement of the Crown Proceedings Act 1947 of the Parliament of the United Kingdom might in England have been preferred against the Crown by petition, manifestation or plea of right may, with the consent of the Attorney-General of the Federation, be preferred in a High Court having original jurisdiction in respect thereof or if the Supreme Court has such jurisdiction, in that Court, in a suit instituted by the claimant as plaintiff against such person as the said Attorney-General may designate, as defendant, for the purpose."

**Section 4**

*Re-number* as subsection (1) and—

(a) *delete* "a copy" and *substitute* "two copies";

(b) *delete* "or other officer designated as aforesaid";

*Add* a new subsection (2) as follows—

"(2) The decision of the Attorney-General of the Federation shall be conclusive and, if he gives his consent, one copy of the statement of claim with his fiat endorsed shall be returned to the court having original jurisdiction; and the claim shall be prosecuted in that court."

**Section 5**

*Delete* this section

**Section 6**

*Delete* "or other officer designated as aforesaid"

**Section 7**

Delete all words after "court to the" up to "direct" where it first occurs and substitute "Attorney-General of the Federation who, if the decree is for the payment of money, shall direct the issue of a warrant for"

**Section 8**

In paragraph (a) delete "a superior court" and substitute "the court in which proceedings are brought, or the Supreme Court, as the case may be,"

**Section 9**

Insert after "shall" the words, "as to matters within federal competence,"

**Section 10**

Delete all words after "references to the" up to the end of the section and substitute "Attorney-General of the Federation shall be construed as references to the Attorney-General of the Region concerned."

**Section 11**

Delete this section

**Section 12**

Delete all words after "conferred on the" up to the end of the section and substitute "Supreme Court by subsection (1) of section one hundred and fourteen of the Constitution of the Federation."

**PETROLEUM ACT**  
(CAP. 150)

**Section 3**

In subsection (1) delete "Governor-General in Council" and substitute "Federal Minister charged with responsibility for explosives"; and in paragraph (i) of the said subsection, delete "the Governor-General in Council" and substitute "Parliament" and thereafter delete "him" and substitute "Parliament"

Insert a new subsection thereafter as follows—

"(1A) The Minister may consult with any Federal or Regional Minister before making any such regulations, but the question whether any consultation was held or what happened in the course of a consultation shall not be enquired into by any court."

In subsection (2) insert after "Region" the words "or in the case of Lagos, the Minister"

**Section 4**

Insert after "Minister" the words "in the case of Lagos"

**Section 5**

Delete all words after "Lagos" up to the end of the section and substitute "as if it were a Region"

**PETROLEUM FUEL (CONTROL) ACT**  
(CAP. 151)

**Section 3**

In subsection (1) delete "Governor-General in Council" and substitute "Federal Minister charged with responsibility for petroleum"

In subsection (2) delete "Governor-General in Council" and substitute "said Minister"

PHARMACY ACT  
(CAP. 152)

**Section 69**

In subsection (1) *delete* "Governor-General in Council" and *substitute* "President"

In subsection (2) *insert* after "Region" the words "or in the case of Lagos, the Minister"

**Section 70**

*Delete* all words after "Lagos" up to the end of the section and *substitute* "as if it were a Region"

PIERS ACT  
(CAP. 153)

**Section 5**

In paragraph (b) *delete* "Governor-General" where it twice occurs and *substitute* "Minister"

**Section 6**

*Delete* "Governor-General" and *substitute* "Minister"

**Section 7**

*Delete* "Governor-General" where it twice occurs and *substitute* "Minister"

**Section 8**

*Delete* "Governor-General" and *substitute* "Minister"

**Section 13**

*Delete—*

(a) "Marine Officer" and *substitute* "Inspector of Shipping";

(b) "Governor-General" and *substitute* "Minister"

**Section 14**

*Delete* "Governor-General in Council" and *substitute* "Minister"

**Section 15**

In subsection (1) *delete* all words after "declared by" up to "Governor in Council" and *substitute* "Parliament to be an international waterway or inter-Regional waterway, the functions of the Minister shall be vested in the Governor"

*Delete* subsection (2)

POLICE ACT  
(CAP. 154)

**Section 9**

*Delete* all words after "service with" up to "Nigeria" where it secondly occurs and *substitute* "the armed forces of Nigeria or any force for the time being attached thereto or acting therewith"

**Section 16**

In subsection (2) in paragraph (a) *delete* "native" and *substitute* "customary"

**Section 18**

In subsection (4) *delete* "Her Majesty" and *substitute* "Nigeria"

**Section 2**

In the definition of—

- (a) "Minister" *delete* all words after "means" up to "1954" and *substitute* "the Federal Minister charged"
- (b) "Public Service Commission" *delete* from "established" to the end of the definition and *substitute* "of the Federation"

**Section 4**

*Delete* "Governor-General in Council" and *substitute* "President"

**Section 8**

In subsection (1) (as replaced by subsection (2) of section one of the Ports Act 1963) *delete* the reference to "seventeen" and *substitute* "twenty"; and in the reference to "nine shall be appointed" as provided in paragraph (b) of the replacing subsection, where reference is made to "nine shall be appointed", *delete* "nine" and *substitute* "twelve"; and *insert* in the said paragraph after "Western Nigeria" the words "as respects three others, from Mid-Western Nigeria"

In subsection (5)—

- (a) *delete* "Governor-General in Council" where it twice occurs and *substitute* "Minister"
- (b) *delete* "Crown" and *substitute* "State"

**Section 11**

In subsection (1) in paragraph (d) *delete* "Governor-General in Council" and *substitute* "Council of Ministers"

**Section 26**

*Delete* this section

**Section 29** (as substituted by section six of the Ports (Amendment) Act 1960)

In subsection (1) *delete* "Governor-General in Council" and *substitute* "Council of Ministers"

**Section 34**

In subsection (2) *delete* "Governor-General" and *substitute* "President"

**Section 35**

*Delete* "Governor-General in Council" and *substitute* "Council of Ministers"

**Section 38**

*Delete* "Resident of the Province" and *substitute* "responsible Minister in the Region"

**Section 42 I** (as inserted by paragraph (b) of section three of the Ports (Amendment) Act 1961)

*Delete* "Crown" and *substitute* "State"

**Section 43**

*Delete* all words after "purposes of" up to "requires" and *substitute* "the Customs and Excise Management Act 1958, the Authority shall set apart and maintain such area, and provide office accommodation therein, in such manner as the Board of Customs and Excise"

**Section 46**

In subsection (2) in paragraph (a) *delete* "Her Majesty" and *substitute* "any of the armed forces of Nigeria or owned or operated by the government of the Federation or of any Region"

**Section 71**

Delete "Her Majesty" and substitute "any government of the Federal Republic"

**Section 75**

In subsection (1) in paragraph (f) delete "Queen's" and substitute "State"

**Section 80**

In subsection (1) delete "Customs and Excise Department" and substitute "Board of Customs and Excise"

**Section 84**

Delete "Her Majesty" and substitute "any of the armed forces of Nigeria or of the governments of the Federation or any Region"

**Section 86**

In subsection (3)—

(a) in paragraph (b) delete "Queen's enemies" and substitute "enemies of the State"

(b) thereafter delete all words after "Act" where it first occurs in the subsection up to "that Act" where it first occurs and substitute "1962"

**Section 88**

In subsection (1)—

(a) in paragraph (b) delete "Queen's enemies" and substitute "enemies of the State"

(b) thereafter delete all words after "Act" where it first occurs in the subsection up to "that Act" where it first occurs and substitute "1962"

**Section 91**

In paragraph (a) of the proviso to the section in subparagraph (ii) delete "Queen's enemies" and substitute "enemies of the State"

**Section 119**

Delete "Customs Act" and substitute "Customs and Excise Management Act 1958"

## POST OFFICE ACT (CAP. 156)

**Section 2**

(a) In the definition of "fictitious postage stamp" delete "Her Majesty's dominions" and insert "of the Commonwealth or"

(b) Delete the definition "Her Majesty's dominions" and insert the following—

"Commonwealth" includes any colonies, trust territory or any territory over which there is a mandate from the former League of Nations belonging to or controlled by any member of the Commonwealth ;"

(c) In the definition of "postage stamp" delete all words after "whether" up to the end of the definition and substitute "such postage stamp is issued by Nigeria or by any other country"

(d) in the definition of "port" delete all words therein after "place" and substitute "designated a customs port or customs airport under any enactment ;"

**Section 7**

In subsection (1) delete "Governor-General" and substitute "Public Service Commission of the Federation"

**Section 12**

Delete subsection (2) (as inserted by the Adaptation of Laws (Cameroons Provision) Order, 1960)

**Section 20**  
Delete all words after "Department" where it secondly occurs up to "foreign" and substitute "of any other"

**Section 28 and section 37 paragraph (g)**  
Delete "Governor-General in Council" and substitute "Minister"

### PROBATES (RESEALING) ACT (CAP. 161)

In the long title delete "Her Majesty's Dominions" and substitute "the Commonwealth or"

#### Section 2

(a) In the definition of "British court in a foreign country" delete "out of Her Majesty's dominions" and substitute "outside the Commonwealth"

(b) Delete the definition of "High Court of a Region or part of the Federation" and substitute—

"High Court" means the High Court of a Region or of Lagos, as the case may require ;

(c) Delete the definition "Her Majesty's dominions" and insert the following—

"Commonwealth" includes any colonies, trust territory or any territory over which there is a mandate from the former League of Nations belonging to or controlled by any member of the Commonwealth ;

(d) Delete the definition "part of the Federation"

(e) In the definition of "probate" and "letters of administration" delete "Her Majesty's dominions" and insert "the Commonwealth"

#### Section 3

(a) Delete "Her Majesty's dominions" and insert "the Commonwealth"

(b) Delete the words "of a Region or part of the Federation",

(c) Delete the words "that Region or part of the Federation" and substitute "Nigeria"

#### Section 4

(a) Delete "of a Region or part of the Federation"

(b) In paragraphs (a) and (b) thereof delete "that Region or part of the Federation" and substitute in both cases "Nigeria"

#### Section 5

(a) Delete "of a Region or part of the Federation",

(b) Delete "that Region or part of the Federation" and substitute "Nigeria"

#### Section 7

In subsection (1) (as amended by the Adaptation of Laws (Miscellaneous Provisions) Order, 1960) delete all words after "High Court" where it first occurs up to "Governor-General" where it last occurs.

### PUBLIC ARCHIVES ACT (CAP. 163)

#### Section 2

In the definition of "archives" delete in paragraph (b) the words "and the Southern Cameroons"

In the definition of "public office" delete all words after "Region" up to "Cameroons" where it secondly occurs and substitute, "the Supreme Court, all High Courts,"

#### Section 5

Delete "House of Representatives" and substitute "Parliament"

**Section 6**

In subsection (2) *delete* "or of the Southern Cameroons"

**Section 8**

*Delete* "Governor-General" and *substitute* "President"

**Section 9**

In subsection (1)—

- (a) *delete* "the Federation" and *substitute* "Nigeria"  
 (b) *delete* "fifteen" and *substitute* "sixteen" and *insert* immediately following the words "Eastern Region" the words "one by the Governor in Council of the Mid-Western Region,"

PUBLIC LANDS ACQUISITION ACT (CAP. 167)

**Section 2**

In the definition of "native community" *delete* all words after "community" where it secondly occurs and *substitute* "elsewhere than in the Northern Region"

**Section 3**

In subsection (1) *delete* "Governor-General" and *substitute* "President"  
 In subsection (2) *delete* "Crown" where it twice occurs and *substitute* "State"

**Sections 4 (1), 5, 6 (1), 8 (2), 10 and 14.**

*Delete* "Governor-General" where it occurs and *substitute* "President"

**Section 15**

In the second proviso where they respectively occur—

- (a) *delete* "Her Majesty's Forces or any department of Government or of the Crown" and  
 (b) *delete* "Her Majesty's Forces or by the department of Government or of the Crown"—  
 and *substitute* in both cases "the armed forces of Nigeria or a department of Government or of the State, as the case may be"

**Sections 16, 17, 18 (1), 19, and 20 (2)**

*Delete* "Governor-General" where it occurs and *substitute* "President"

**Section 20**

In subsection (1) *delete* all words after "decision" where it first occurs up to "been taken" and *substitute* "of the Court on appeal taken"

*Add* after subsection (5) a new subsection as follows—

"(6) In this section "Court" means the High Court, and as the case may be includes the Supreme Court and, in appropriate case and to the extent allowed by section 158 of the Constitution of the Federation, the Privy Council."

**Sections 22 and 23**

*Delete* "Governor-General" and *substitute* "President"

**Section 26**

*Delete* all words after "Governor-General" up to "estate or" and *substitute* "President in trust for the State, the"

**Section 27**

(a) *Delete* "the Governor-General" where it first occurs and *substitute*

"a Federal Minister"

(b) *Delete* "Governor-General" and *substitute* "State"

**Section 28**

*Delete* "person duly authorised by the Governor-General" and *substitute* "duly authorised person"

**Sections 30 and 31**  
Delete "Governor-General" where it occurs and substitute "State"

**Section 31**  
Delete "Crown" and substitute "State"

**Section 32**  
In paragraph (a) delete "Governor-General" and substitute "President"

In paragraph (b)—

(a) insert after "Eastern" the words, "Mid-Western,"

(b) delete all words therein after "Regions" where it secondly occurs

In paragraph (d)—

(a) insert after "Western" the words "or Mid-Western"

(b) delete all words therein after "Region"

**Section 34**  
Delete this section

#### Schedule

1. In Form "A" delete "Governor-General" where it occurs and substitute "State" and delete "him" and substitute "the State"

2. In Form "B"—

(a) delete "Governor-General" where it occurs and substitute "President"

(b) in the habendum delete "to the use of Her Majesty, Her heirs and successors" and substitute "in trust for the State and on behalf of the Federation"

3. In Form "C"—

(a) delete "Governor-General" where it occurs and substitute "President"

(b) in the habendum delete "in trust for Her Majesty, Her heirs and successors" and substitute "unto the President in trust for the State"

4. In Form "D" delete from "Governor-General" up to "Her Majesty" and substitute "President in trust for the State and on behalf of the Federation"

5. In Form "E"—

(a) delete "Governor-General" where it occurs and substitute "President"

(b) delete "employed by him" and substitute "authorised by a Federal Minister"

6. In Form "F" delete "Governor-General" where it occurs and substitute "State"

### PUBLIC TRUSTEE ACT (CAP. 170)

#### Section 4

Delete subsection (1) and substitute—

"(1) There may from time to time be appointed a fit person to the office of Public Trustee and such office may be held in conjunction with any other office which the Public Service Commission of the Federation may approve."

In subsection (2)—

(a) delete "The Governor-General may appoint" and substitute "There may also be appointed"

(b) delete "he considers" and substitute "are considered"

#### Section 8

In subsection (2) delete in paragraph (g) the words "of the Imperial Parliament or Act" and substitute "or Law"

#### Section 10

Delete all words after "Court" up to "Governor-General"

**Section 19**

In subsection (3) *delete* "into the Treasury" and *substitute* "to the Accountant-General of the Federation for credit of the appropriate Fund"

**Section 23**

*Delete* "Governor-General in Council" and *substitute* "President"  
QUARANTINE ACT (CAP. 172)

**Section 4**

*Delete* "Governor-General in Council" and *substitute* "President"

**Section 6**

*Insert* after "Minister" the words "in the Federal territory"

**Section 8**

In subsection (1)—

(a) *insert* immediately after "been made" where it first occurs, the words "by the Minister,"

(b) *delete* "Governor-General" where it first occurs and *substitute* "President,"

(c) *delete* "Governor-General" where it secondly occurs and *substitute* "Minister or the President, as the case may be,"

*Delete* subsection (2)

**RAILWAY LOAN (INTERNATIONAL BANK) ACT (CAP. 174)**

*Insert* immediately following section 8 a new section as follows—

"Interpretation of Governor-General.

9. References in this Act to the Governor-General, in respect of anything done or to be done on the first day of October 1963 (being the date of the commencement of the Constitution of the Federation) and thereafter, shall be read as references to the Federal Minister of Finance and this Act shall be construed accordingly; and any reference to a Secretary of State shall cease to have effect."

**RECIPROCAL ENFORCEMENT OF JUDGMENTS ACT (CAP. 175)****Section 5**

*Delete* this section and *substitute*—

"Power to extend provisions of this Act.

5.—(1) Where the President is satisfied that arrangements have been made as between Nigeria and any other country of the Commonwealth (including any territory administered by the United Kingdom) for the reciprocal enforcement of judgments obtained in superior courts of the country concerned and of Nigeria, he may by order declare that this Act shall extend to judgments so obtained in the country with which such arrangements have been made in like manner as it extends to judgments obtained in a superior court in the United Kingdom; and upon the making of such proclamation this Act shall extend and apply accordingly.

(2) Any order made under this section may at any time be varied or revoked.

(3) For the purposes of this section—

(a) the President may act on information received from—

(i) the Governor-General, President, or Governor, as the case may be, of any member of the Commonwealth, and

(ii) the Secretary of State in respect of any territory administered by the United Kingdom, including any mandated or trust territory; and  
 (b) "superior court" means a High Court and includes any court by whatever name called of equivalent or superior jurisdiction."

REGIONAL COURTS (FEDERAL JURISDICTION) ACT  
 (CAP. 177)

In the long title *delete* "Queen's" and *substitute* "State"

**Section 6**

*Delete* from the commencement up to the word "who", and *substitute* "The President may, with the consent of the Governor of a Region, confer upon the Attorney-General of the Region the power to intervene in a matrimonial cause under the title of state proctor and if the power is conferred, the said Attorney-General"

**Section 7**

*Delete* this section

REGISTRATION OF UNITED KINGDOM PATENTS ACT  
 (CAP. 182)

**Section 2**

In the definition of "Registrar of Patents" *delete* "Governor-General" and *substitute* "Public Service Commission of the Federation"

SAVINGS BANK ACT (CAP. 188)

**Section 6**

*Delete* "Governor-General" and *substitute* "Public Service Commission of the Federation or of a Region, as the case may be,"

**Section 12**

(a) *delete* "of Federal Audit" and *substitute* "Audit of the Federation,"  
 (b) *delete* "House of Representatives" and *substitute* "both Legislative Houses", and

(c) *delete* all words after "Gazette"

**Section 13**

In subsection (3)—

*Delete* "with the prior consent of the Secretary of State" and *substitute* "after consultation with the Federal Minister of Finance,"

**Section 14**

*Delete* "Governor-General in Council" and *substitute* "President"

**Section 15**

*Delete* all words after "Government Savings Bank" up to "foreign country" and *substitute* "of any other country".

SHERIFFS AND CIVIL PROCESS ACT (CAP. 189)

**Section 1**

In subsection (3)—

(a) *insert* immediately after "Western" in paragraph (a) the word "Mid-Western,"

(b) *delete* all words after "Lagos" in paragraph (b) up to the end thereof and *substitute* "as if it were a Region".

**Section 19**

In the definition of—

- (a) "the High Court" *delete* all words after "means" and *substitute* "the High Court of Lagos",  
 (b) "magistrates' court" *delete* all words after "established" and *substitute* "in Lagos".

**Section 29**

In subsection (4) in its application to Lagos, *delete* "Nigeria" and *substitute* "Lagos".

**Section 45**

*Delete*—

- (a) "native" where it first occurs and *substitute* "Nigerian",  
 (b) "native law or custom" and *substitute* "customary law".

**Section 94**

*Delete* the words "with the approval of the Governor" and *insert* "of Lagos in respect of the Federal territory".

In Part VII *delete* from the heading the words "The Southern Cameroons".

**Section 113** (as inserted by the Adaptation of Laws (Cameroons Provisions) Order 1960).

*Delete* "Northern and Southern".

## STATISTICS ACT (CAP. 193)

**Section 3**

*Delete* "Governor-General" and *substitute* "President".

**Section 6**

In subsection (1)—

- (a) in paragraph (b) *delete* all words after "List" up to "and",  
 (b) in paragraph (c) *delete* all words after "concerned" up to "Southern Cameroons".

**Section 7**

In subsection (1) in paragraph (b) *delete* "and the Southern Cameroons".

**Section 13**

*Delete* "or of the Southern Cameroons".

**Section 14**

*Delete* "Governor-General" and *substitute* "Minister".

**Sections 19 and 20**

*Delete* "Governor-General in Council" where it appears and *substitute* "President".

## SURVEY ACT (CAP. 194)

**Section 2**

In the definition of "public survey" *delete* "Crown" where it twice occurs and *substitute* "State".

**Section 7**

In subsection (1) *delete* "Southern Cameroons" and *substitute* "Mid-Western".

**Section 8**

In subsection (2) *delete* "Legal Department" and *substitute* "Ministry of Justice".

**Section 30**  
In subsections (1) and (2) *delete* "native" and *substitute* "local".

**Section 37**  
*Delete* "Governor-General" and *substitute* "Minister in respect of Lagos".

**Section 39**  
*Delete* all words after "Lagos" up to the end of the section and *substitute* "as if it were a Region and accordingly—

(a) references to the powers of a Governor shall, in respect of Lagos, be construed as references to the powers of the Federal Minister charged with responsibility for survey matters, and

(b) references to a regional director of surveys, shall be construed as references to the director of federal surveys."

### TELEGRAPHS ACT (CAP. 195)

**Section 2**  
*Insert* immediately after the definition of "Manager" a new definition as follows—

"Minister" means the Federal Minister charged with responsibility for telegraphs ;

**Section 12**  
*Insert* immediately after the words "sent by" the words "the President in his office as President, or by the"

**Section 23**  
*Delete* "Governor-General in Council" and *substitute* "Minister".

### TIN (PRODUCTION AND EXPORT RESTRICTION) ACT (CAP. 197)

**Section 5**  
*Delete* all words after "apply to" up to the end of the section and *substitute* "Northern Nigeria".

**Section 6**  
In subsection (2) *delete* "the Northern Region" where it twice occurs and *substitute* "Northern Nigeria".

**Sections 7(1), 8(1) and 11(1)**  
*Delete* "the Northern Region" and *substitute* "Northern Nigeria".

**Section 12**  
In subsection (1)—  
(a) *delete* "Mines Department" and *substitute* "mines division of the ministry responsible for the control of mines"

(b) *delete* "Her Majesty" and *substitute* "the State"

(c) *delete* "Governor-General" and *substitute* "Minister".

**Section 16**  
In the proviso *delete* "the Northern Region" and *substitute* "Northern Nigeria".

**Section 18**  
*Delete* "Governor-General is pleased to declare" and *substitute* "the President by order in the Gazette declares".

TOBACCO (LICENCES AND RETURNS) ACT  
(CAP. 198)

In the long title *delete* all words after "provision" and *substitute* "for licences to and returns by importers into Nigeria of tobacco for purposes incidental to the regional allocation of the proceeds of import duty thereon in respect of each quarter under the Constitution of the Federation".

*Delete* the preamble.

In the enacting formula *delete* "Now, Therefore".  
In section 2, in the definition of—

(a) "dutiable tobacco" *delete* "Customs Act" and *substitute* "Customs and Excise Management Act 1958",

(b) "prescribed authority" *delete* all words after the figures "1951" and *substitute* "as amended by this Act and hereinafter referred to as "the 1951 Order" and appointed by the Minister",

(c) "tobacco manufacturer's licence" *delete* "issued under section 40 of the Excise Act" and *substitute* "under section one hundred and five of the Customs and Excise Management Act 1958".  
*Insert* immediately after section 2 a new section as follows—

"Interpretation.

2A. In this Act, "Minister" means the Federal Minister charged with responsibility for the allocation of tobacco duty; and for the avoidance of doubt, the reference in section 6 of the 1951 Order to the Governor shall be read as a reference to the Minister under this Act, and the 1951 Order shall be deemed to be amended to the extent necessary to give effect thereto."

**Section 8**

In subsection (4) *delete* "of the High Court"

**Section 12**

*Delete* "Customs Act" and *substitute* "Customs and Excise Management Act 1958"

**Section 14**

*Delete* all words after "Lagos" up to the end of the section and *substitute* "as if it were a Region"

TRADE MARKS ACT (CAP. 199)

**Section 2**

In the definition of "Registrar" *delete* "Minister" and *substitute* "Public Service Commission of the Federation"

**Section 7**

*Delete* "the Northern Region" and *substitute* "Northern Nigeria"

**Section 61**

*Delete* "Governor-General in Council" and *substitute* "President"

**Section 64**

*Delete*—

(a) all words after "in writing" up to "that goods" and *substitute* "to the proper officer under the Customs and Excise Management Act 1958",

(b) all words after "be detained" up to "until the rights" and *substitute* "by such proper officer"

(c) in the proviso *delete* all words after "reimburse" up to "all expenses" and *substitute* "to such proper officer"

**Section 65**

In subsection (3) *delete* all words after "authority" where it first occurs up to the proviso, and *substitute* "of the President uses in connection with any trade, business, calling or profession the Arms of Nigeria, or, without the authority of a Governor of a Region likewise so uses the Arms of the Region (in this subsection such Arms being collectively referred to as "the said Arms") or arms so closely resembling the said Arms or any of them as to be calculated to deceive, in such manner as to be calculated to lead to the belief that he is duly authorised to use any of the said Arms, or if any person without the authority of the President or of the Governor of a Region, as the case may be, uses in connection with any trade, business, calling or profession any device, emblem, or title in such manner as to be calculated to lead to the belief that he is employed by or supplies goods to the President or to a Governor of a Region in their respective official capacities, as the case may be, he shall be guilty of an offence and liable to a fine of twenty pounds ;"

**Section 67**

*Delete* "Governor-General in Council" and *substitute* "President "where it occurs

## TRADE UNIONS ACT (CAP. 200)

**Section 11**

*Delete* from the commencement up to "may think" and *substitute* "The Public Service Commission of the Federation may appoint such person as it thinks"

**Section 17**

In subsection (3) *delete* "Federal"

**Section 33**

*Delete* "Governor-General in Council" where it appears and *substitute* "President"

**Second Schedule**

In Forms L and O *delete* "Statutory Declarations Act 1835" and *substitute* "Oaths Act 1963"

TRADES DISPUTES (ARBITRATION AND INQUIRY)  
(FEDERAL APPLICATION) ACT (CAP. 202)**Section 4**

In subsection (1) *delete* in the proviso all words after "authorised" up to the end of the subsection and *substitute* "by the Public Service Commission of the Federation or of a Region, as the case may be, in respect of officers in the public service, shall be paid to any person who holds an office which is a public office for the purposes of the Constitution of the Federation".

In subsection (2) *delete* from the commencement up to "determine" and *substitute* "There may be appointed at such remuneration and on such terms and conditions as may be determined"

In subsection (3) *delete* all words after "paid out of" up to the end of the subsection and *substitute* "the Consolidated Revenue Fund"

**Section 5**

*Delete* "Governor-General" and *substitute* "relevant public service commission"

TRUSTEE INVESTMENT IN GOVERNMENT SECURITIES  
ACT (CAP. 203)

**Titles**

For the reference in section 2 of an amending Act of 1960 (No. 37 of 1960) to the principal Act as the "Government Securities Act" there shall be substituted the reference "Trustee Investment in Government Securities Act"; and the long and short titles of such amending Act shall be altered correspondingly.

**Section 2** (of the principal Act)

Delete "Imperial Parliament" and substitute "Parliament of the United Kingdom"

**Section 5** (of the principal Act)

Delete "Auditor-General" and substitute "Director of Audit of the Federation"

**Section 6** (as replaced by the amending Act of 1960)

(a) Delete "Her Majesty's" where it thrice occurs and substitute "the",

(b) Delete "submitted to the Governor-General for his assent" and substitute "introduced into the Parliament of the Federation"

UNIVERSITY COLLEGE HOSPITAL ACT (CAP. 205)

**Section 2**

In the definition of "the Minister" delete all words after "means" up to the end of the definition and substitute "the Federal Minister charged with responsibility for matters relating to hospitals"

**Section 5**

In subsection (3) in paragraph (e) delete sub-paragraph (i) and substitute—  
"(i) the permanent secretary of the Federal Ministry of Health,"

**Section 12**

In subsection (1) in paragraphs (d) and (e) delete "Governor-General" where it occurs and substitute "Minister",

In subsection (2) delete "House of Representatives" and substitute "both Legislative Houses"

**Section 17**

Delete "Governor-General" and substitute "Minister"

VETERINARY SURGEONS ACT (CAP. 210)

**Section 27**

Delete "Legal Department" and substitute "Ministry of Justice"

**Section 31**

In subsection (1) delete "Federal" where it twice occurs

WAGES BOARD ACT (CAP. 211)

**Section 1**

Delete subsection (2)

**Section 4(1)**

(a) delete "the Western Region" where it occurs and substitute "Western Nigeria",

(b) insert after "Regional Law or" the words "as the case may be in respect of"

**Second Schedule**

In paragraph 8 delete "Governor-General in Council may determine" and substitute "Federal Minister of Finance may from time to time approve"

## WAR PENSIONS ACT (CAP. 212)

**Section 1**

Add a new subsection as follows—

"(2) This Act shall apply in respect of war service only as defined in this Act, and references to "Her Majesty" or to "Her Majesty's Forces" shall be construed accordingly."

**Section 3**

In subsection (1) *insert* after "State" or in respect of any period after the first day of October, 1963 the President without the necessity for any such sanction"

In subsection (2)—

(a) *insert* in paragraph (e) after "Governor-General" where it twice appears the words "or the President as the case may be"

(b) *delete* "Governor-General" in paragraph (k) and *substitute* "Minister"

**Section 5**

*Insert* a new subsection (1A) immediately after subsection (1) as follows—

"(1A) The powers conferred upon the Governor-General in Council by subsection (1) of this section may, on the coming into operation of the Constitution of the Federation be exercised by the President."

**Section 7**

*Delete* "Governor-General" and *substitute* "Minister"

**Section 8**

*Delete* "House of Representatives" where it twice occurs and *substitute* "both Legislative Houses"

**Section 10**

*Delete* "Crown" and *substitute* "State"

**Section 11**

*Delete* "Governor-General" where it occurs and *substitute* "Minister"

**Section 12**

(a) *Delete* "Governor-General" where it twice occurs and *substitute* "Minister"

(b) *Delete* "Crown" and *substitute* "Federal Government"

## WATERWORKS ACT (CAP. 213)

**Section 2**

In the definition of "appropriate officer" *delete* all words after "Minister" up to the end of the definition

**Section 3**

(a) *Delete* "the Minister" where it first occurs and *substitute* "Parliament"

(b) *Delete* "or the Southern Cameroons"

**Section 16**

In subsection (1) *insert* after "Minister may" the words "in respect of Lagos or the control of water from sources within the operation of section 3 of this Act"

**Section 14** WEIGHTS AND MEASURES ACT (CAP. 214)

*Delete* this section save for the marginal note and *substitute* the following new section—

"14. The person who for the time being holds office as superintendent of weights and measures shall by virtue of such office be deemed to be the inspector for the purposes of this Act. If the office of superintendent is vacant it may be filled under the designation of either superintendent or

inspector as the appointing authority may from time to time approve or direct; and the person so appointed shall have all the powers of the inspector under this Act."

**Section 15**

In subsection (1) *delete* from the commencement up to "think fit" where it secondly occurs and *substitute* "There may be appointed fit persons to be deputy inspectors for the purposes of this Act; and there shall be assigned a portion of Nigeria".

**Section 45**

In subsection (1) *delete* "Governor-General in Council" and *substitute* "Minister"

WEST AFRICAN COUNCIL FOR MEDICAL RESEARCH ACT  
(CAP. 215)

**Section 1**

*Delete* "of" and *substitute* "for"

**Section 4**

In subsection (1) *delete* "Governor-General" in paragraph (b) and *substitute* "President"

**Sections 9, 10, 17, and 18**

*Delete* "Governor-General" where it occurs in the sections and *substitute* "President"

**Section 19**

In subsection (1) *delete* "Governor-General" and *substitute*

**Section 20**

In subsections (1), (3) and (6) *delete* "Governor-General" and *substitute* "Minister" and *substitute* "Minister"

**Section 22**

*Delete* "Governor-General" and *substitute* "President"

WEST AFRICAN EXAMINATIONS COUNCIL (NIGERIAN  
STATUS) ACT (CAP. 217)

**Section 4**

In subsection (1) *delete* "Governor-General" and *substitute* "President"

In subsection (3) *delete* "Governor-General" and *substitute* "Minister"

WIDOWS' AND ORPHANS' PENSIONS ACT  
(CAP. 220)

**Section 3 (2)**

In paragraph (b) *delete*—

(a) "Governor-General" and *substitute* "Minister"

(b) "Governor-General's" and *substitute* "Minister's"

**Section 4 (1)**

In paragraph (d) *delete* "of Her Majesty's Orders in Council" and *substitute* "Orders in Council made in the United Kingdom"

In paragraph (g) *delete* "by the Secretary of State"

**Section 5 (1)**

*Delete* "Governor-General" and *substitute* "Minister"

**Section 6 (1)**

In paragraph (b) (ii) *delete* "Governor-General" and *substitute* "Minister"

In paragraph (b) (iii) *delete* "Governor-General's" and *substitute* "Minister's"

**Section 18 (2) and (3), 21**

Delete "Governor-General" and substitute "Minister"

**Section 33**

In subsection (2) delete "Chief Secretary" and substitute "Minister"

**Section 37**

(a) In subsection (1) delete all words after "serving with" up to "so served" and substitute "the armed forces of Nigeria in time of war or in consequence of having so served with any such force or in the case of service with the forces known as Her Majesty's Forces in time of war prior to the first day of October, 1960"

(b) In subsection (2) delete from the commencement up to "Governor-General" where it secondly occurs and substitute "Where an officer with any necessary approval leaves or has left the service of Nigeria for the purpose aforesaid with the expressed intention of returning to service in Nigeria as soon as practicable after the termination of his service with any such armed force he may, by electing in such manner as may be prescribed and notwithstanding any other provision of this Act,"

(c) In the proviso to subsection (2) in paragraph (b) delete "Crown" and substitute "State"

In subsection (4) delete "Governor-General or the Secretary of State" and substitute "Minister"

In subsection (5)

(a) delete "Her Majesty's Forces" and substitute "the armed forces of Nigeria or as the case may be in the forces known as Her Majesty's Forces"

(b) delete "Governor-General" and substitute "Minister"

**Sections 38 and 39**

Delete "Governor-General" where it occurs and substitute "Minister"

**Section 41**

Delete "Governor-General in Council" and substitute "President"

**Section 46** (as replaced by section 6 of the Widows' and Orphans' Pensions (Amendment) Act 1960 and there referred to as section 47)

In subsection (2) delete "Governor-General" and substitute "President"

**WORKMEN'S COMPENSATION ACT**

(CAP. 222)

**Section 3**

In subsection (1)—

(a) in the definition of "court" delete "Governor-General" and substitute "President"

(b) in the definition of "employer" delete all words after "includes" up to "and any body of persons" and substitute "the Government of the Federation and of any Region thereof"

In subsection (2) delete "Her Majesty's" and substitute "the"

**Section 4**

In subsection (1)—

delete "Crown" and substitute "State" where it twice occurs delete from "employment" in paragraph (ii) of the exceptions up to "who have been" and substitute "of the State otherwise than in the government of the Federation or of any Region and"

In subsection (3) *delete* "Governor-General" where it twice occurs and *substitute* "Minister"  
 In subsection 4 *delete* "Governor-General" and *substitute* "Minister"

### Section 10

In subsection (5) *delete* "public revenues of the Federation" and *substitute* "Consolidated Revenue Fund"

### Section 22

In subsections (2) and (4) *delete* "other" where it first occurs in the subsections,

*Delete* from the commencement of subsection (5) up to "colony" where it first occurs and *substitute*—

"(5) In this section, "colony" means any British Colony in Africa and includes any former"

### Sections 35 (1) and 36 (1)

*Delete* "The Governor-General in Council may make rules" where they occur and *substitute* "The President may make regulations"

### Section 36

In subsection (2) *delete* "with the approval of the Governor-General"

In subsection (3) *delete* all words after "Lagos" up to the end of the subsection and *substitute* "as if it were a Region"

### Section 37

In subsection (1)—

(a) *delete* "Her Majesty's dominions" and *substitute* "the Commonwealth"

(b) *delete* "Governor-General in Council" and *substitute* "President"

(c) in paragraph (b) *delete* "appointed by the Governor-General" and *substitute* "duly appointed"

In subsection (2) *delete* "Her Majesty's dominions" as words defined and *substitute* "part of the Commonwealth"

## SECOND SCHEDULE ANATOMY ACT (CAP. 11)

### Section 1

*Delete* all words after "Anatomy Act" up to the end of the section

### Section 12

*Insert* after "Council" the words "or in the case of Lagos, the Minister,"

### Section 13

*Delete* all words after "Lagos" up to the end of the section and *substitute* "as if it were a Region"

## ARBITRATION ACT (CAP. 13)

### Section 1

In subsection (2) *delete* all words after "Lagos" up to the end of the subsection and *substitute* "as if it were a Region"

In the definition of—

(a) "court" *delete* "a High Court" and *substitute* "the High Court of Lagos"

(b) "rules of court" *delete* "with the approval of the Governor"

**Section 17**  
Delete "with the approval of the Governor"

**Section 19**  
Delete all words after "Nigeria" up to the end of the section and substitute a party, but nothing in this Act shall affect the law as to costs payable by State."

### AROTAS (CROWN GRANTS) ACT (CAP. 14)

Add immediately following section five a new section as follows—

**6. References in this Act—**  
(a) to the Crown shall as from the date of constitution of Nigeria as a Federal Republic be read and construed as references to the State ;  
(b) to native law and custom shall be read as references to customary law ;  
and this Act shall have effect accordingly."

### ASSESSMENT ACT A.—ASSESSMENT ACT (CAP.15)

**Section 2**  
In subsection (1) in the definition of "owner" delete "Crown" and substitute "State"

In subsection (2) delete all words after "established" up to the end of the subsection and substitute "in the Federal territory under the provisions of this Act or to any tenements or place within such territory shall be construed as a reference to the Minister."

**Section 26**  
Delete "with the approval of the Governor"

**Section 27**  
Delete all words after "respect" up to the end of the section and substitute of the Federal territory as though it were a Region".

### B.—THE ASSESSMENT LAW 1954 OF THE WESTERN REGION ACT

**Section 1**  
In subsection (2) delete "Town of Lagos" and substitute "Federal territory"

**Section 2**  
Add a new subsection (3) as follows—  
"(3) References in this Act to "Governor" or "Governor in Council", to the extent to which this Act applies to the Federal territory, shall be construed as references to the Minister."

### BETTING DUTY ACT (CAP. 20)

**Section 2**  
In the definition of "authorised race club" delete "Governor" and substitute "Minister".

**Section 7**

In subsection (1) *delete* "Governor-General in Council" and *substitute* "Minister"

**BILLS OF SALE ACT**  
(CAP. 22)

**Section 5**

*Delete* this section

**BIRTHS, DEATHS AND BURIALS ACT**  
(CAP. 23)

**Section 4**

*Delete* this section except for the marginal note and *substitute*—

"4.—(1) There may be appointed a fit person to be Principal Registrar for the purposes of this Act.

(2) There may likewise be appointed such Registrars and Deputy Registrars as may from time to time be necessary for the purposes of this Act."

**Section 5**

*Delete* this section and *substitute*—

"Appoint-  
ment of  
registries.

5. The Minister may by notice in the Gazette appoint registry offices and direct for what area and in relation to what class of persons each such office shall be the proper office for the registration of births and deaths under this Act."

**Section 49**

*Insert* after "A Governor in Council" the words "or in Lagos, the Federal Minister of Health"

**Section 50**

*Delete* "Governor-General in Council may" and *substitute* "President may by order"

*Insert* after section 50 a new section 50A as follows—

"Regulations  
and orders  
to be laid  
before  
Parliament.

50A. Regulations made under section forty nine and Orders made under section fifty of this Act shall be laid before both Houses of Parliament as soon as may be after they are made; and if either House, on any of the twenty days on which it sits next after the date on which any such regulations or orders are laid before it resolves that they be annulled, they shall cease to have effect on the day next following the date of the resolution, but without prejudice to anything previously done in pursuance of the regulations or order, as the case may be."

**Section 51**

*Delete* this section and *substitute*—

"51. This Act shall apply to and in respect of Lagos as though it were a Region."

**First Schedule**

(a) In Form A *delete* the sub-head "Non-Native Births Register" and *substitute* a new sub-head of "Births Register of Aliens"

(b) In Form B *delete* the sub-head "Native Births Register" and *substitute* a new sub-head of "Births Register of Nigerians"

(c) In Form C *delete* the sub-head "Non-Native Deaths Register" and *substitute* a new sub-head of "Deaths Register of Aliens"

(d) In Form D *delete* the sub-head "Native Deaths Register" and *substitute* a new sub-head of "Deaths Register of Nigerians"

CHILDREN AND YOUNG PERSONS ACT  
(CAP. 32)

~~Section 12~~  
~~Her Majesty's pleasure~~ and *substitute* "the pleasure of the  
at"

~~Section 13~~  
~~Governor-General~~ and *substitute* "Minister"

~~Section 17~~  
subsection (1) *delete* "The Governor may appoint" and *substitute* "There  
om time to time be appointed"  
subsection (4) *delete* "by the Governor" where the words occur in  
aphs (a) and (b)

~~Section 30~~  
subsection (4) *delete* the words "or crown counsel" where it thrice occurs.

~~Section 32~~  
the first numerical section reference in this Act to "32" *substitute* "31"  
n subsection (1) thereof *delete* "Governor in Council" and *substitute*  
ister"

~~Section 33~~  
*delete* all words after "Lagos" up to the end of the section and *substitute* "as  
gh it were a Region"

COLONIAL CHURCH COUNCIL (INCORPORATION) ACT  
under St. Saviour's Church Council (Incorporation) Act)

CO-OPERATIVE SOCIETIES ACT  
(DIVISION A OF CAP. 39)

~~Section 1~~  
Add at end of this section, "and shall apply to Lagos"

~~Section 2~~  
*Delete* the definition of appropriate registrar  
in the definition of "registrar" *delete* all words after "means" up to the end  
the definition and *substitute* "the registrar of co-operative societies under  
Act, and for the purposes of section 46 of this Act includes any such  
ety registered elsewhere in Nigeria ; "

~~Section 4~~  
*Delete* this section and *substitute*—  
"Appointment of registrar, etc.  
4. There may be appointed a fit person to be registrar of  
co-operative societies and such other persons to assist him  
as may be necessary ; and the persons appointed to assist  
the registrar shall have such of the powers of the registrar  
as may from time to time be conferred upon them by notice  
in the Gazette."

~~Section 5~~  
*Delete* "Governor" and *substitute* "Minister"

~~Sections 9, 11, 13, 19 (1), 27 paragraph (b), 35 (1), 38, 46 (1), (2), (3), (4),  
47 (1), 48, 49 (1), 50 (1), 51, 54 (1), 55, 57, 58 paragraph (1), 59 (1),  
65 (2) (f), (3), and 67 (1) (a).~~

~~delete~~ "appropriate" where it occurs

~~Section 9~~

~~delete~~ all words after "by-laws" where it secondly occurs up to the end of  
~~Section~~

**Sections 19 and 31**

In each subsection (2) *delete* "in his Region" and *substitute* "under this Act"

**Section 34**

In subsection (1) *delete* from the commencement up to "Region" and *substitute* "The Minister by notice in the Gazette may in respect of all or any of the societies registered under this Act"

In subsection (2) *delete* "Regional"

**Section 54**

*Add* a new subsection (6) as follows—

"(6) References in this section to "Governor" or to "Governor of the Region" shall be construed as references to the Minister."

**Section 60**

*Delete* "of the Region"

**Section 65**

In subsection (1) *delete* "A Governor in Council" and *substitute* "The Minister."

**Section 70**

*Delete* this section

CO-OPERATIVE SOCIETIES (LAGOS) MISCELLANEOUS ACT  
(DIVISION B OF CAP. 39)

**Section 6**

In subsection (1) *delete* from paragraph (a) the words "or the Southern Cameroons"

CORONERS ACT  
(CAP. 41)

**Section 31**

*Delete* this section except as to the marginal note and *substitute*—

"31. The powers conferred upon the Attorney-General of the Federation by sections twenty-nine and thirty of this Act may, in Lagos, be exercised through the Director of Public Prosecutions of the Federation acting in accordance with the provisions of section one hundred and four of the Constitution of the Federation."

**Section 37**

*Delete* all words after "Lagos" and *substitute* "as if it were a Region"

CROWN GRANTS (LAGOS) ACT  
(CAP. 44)

**Section 6**

*Delete* "Crown" and *substitute* "State"

DESTRUCTION OF MOSQUITOES ACT  
(CAP. 50)

**Section 1**

In subsection (2) *delete* "Crown" and *substitute* "State"

**Section 2**

In the definitions of—

- (a) "owner" *delete* "Crown" and *substitute* "State", and
- (b) "sanitary authority" *delete* "by a Governor"

**Section 22(6)**

*Delete* "of Nigeria"

**Section 24**

*Delete* all words after "Lagos" up to the end of the section and *substitute* "as if it were a Region"

DISEASES OF ANIMALS ACT  
(CAP. 54)

Section (1) insert after "Governor in Council of a Region" the  
the Minister in respect of Lagos,"

All words after "Lagos" up to the end of the section and substitute  
are a Region"

DOGS ACT  
(CAP. 55)

2  
In alphabetical sequence the following definition—  
Governor" in the application of this Act to Lagos means the Minister ;

25  
Delete "Governor-General in Council" and substitute "Minister"

27  
this section

EDUCATION (LAGOS) ACT  
(CAP. 56)

12  
Section (2) delete "Crown" and substitute "State"

32  
Subsections (2) and (3) delete "Governor-General" and substitute  
"Minister"

61  
Delete "Governor-General" and substitute "Minister"

62  
Subsection (1)—  
Delete "Governor-General" and substitute "Minister," and  
Delete "House of Representatives" and substitute "both Legislative  
Assemblies"

63  
Subsection (1) delete from the commencement up to "Act" and substi-  
tute "Minister" (other  
than the power to make regulations)"  
Subsection (2) delete "Governor-General" and substitute "Public  
Commission of the Federation"

EMPLOYMENT OF EX-SERVICEMEN ACT  
(CAP. 59)

3  
Section (1) delete from the commencement up to "may think" and  
insert "There may be appointed such additional labour officers as may

Section (2) delete from the commencement up to "all such" and  
insert "There may also be appointed"

4  
Delete "Governor-General" and substitute "Minister in respect of Lagos"

38  
Delete "Commissioner of Labour" and substitute "Minister"

ENTERTAINMENT TAX ACT  
(CAP. 60)

B 507

**Section 2**

In subsection (1) *insert* in alphabetical sequence after "entertainment" the following definition—

"Minister" means the Federal Minister charged with responsibility for finance and accordingly references in this Act to "Financial Secretary" in its application to Lagos shall be so construed;

*Delete* subsection (2)

**Section 14**

In subsection (1) *delete* all words after "lawful for" up to "the Federation" and *substitute* "both Houses of Parliament,"

In subsection (2) *insert* after "Governor" the words ", or in the case of Lagos the Minister,"

FORESTRY ACT  
(CAP. 72)

**Section 2**

In the definition of—

(a) "Resident" *delete* all words after "Minister" up to the end of the definition;

(b) "Lands at the disposal of the Government" *delete* the word "Crown" and *substitute* "State"

**Section 63**

*Delete* this section and *substitute* the following new section—

"Applica- 63. This Act shall apply to Lagos as if it were a Region, tion of Act and accordingly in such application references— to Lagos (a) to "Governor" or "Governor-General" without the words "in Council" shall be read as references to the Federal Minister charged with responsibility for forestry;

(b) to the Treasury of a Region shall be read as references to the office administered by the Accountant-General of the Federation; and

(c) to the Chief Conservator of Forests shall be construed as references to the Permanent Secretary of the Ministry concerned with forestry."

GOLDSMITHS ACT  
(CAP. 77)

**Section 2**

In the definition of "Resident" *delete* all words after "Council" and *substitute* "and accordingly, references in this Act to any administrative officer shall be construed as references to any such officer in the employ of that Council;"

**Section 11**

In subsection (1) *delete* the words "officer of the Mines Department" and *substitute* "duly authorised under this Act, or officer of the mines division of the ministry of the Federation responsible for minerals,"

**Section 15**

*Insert* after "Governor in Council of a Region" the words "or in respect of Lagos, the Minister charged with responsibility for minerals"

**Section 16**

*Delete* all words after "Lagos" up to the end of the section and *substitute* as if it were a Region"

## HIDES AND SKINS ACT (CAP. 79)

**Section 2**

*Delete* "Governor in Council" and *substitute* "Minister"

**Section 3**

*Delete* "Governor-General in Council" and *substitute* "Minister"

**Section 4**

*Delete* all words after "Lagos" up to the end of the section and *substitute* "as if it were a Region"

## HIGH COURT OF LAGOS ACT (CAP. 80)

**Section 2**

In subsection (1), in the definition of—

(a) "Chief Justice" *delete* the words "of the High Court,"

(b) "Federal Supreme Court" *delete* the word "Federal" where it twice occurs

**Section 5**

*Delete* this section and *substitute*—

"Appointment of Chief Justice and other judges and tenure of office.

5.—(1) Any person if duly qualified may be appointed as Chief Justice of Lagos or other judge of the High Court in manner prescribed by section one hundred and twenty-three of the Constitution of the Federation; and any such office if vacant or the office holder is unable to perform the functions of his office, may be filled in an acting capacity by some duly qualified person in like manner under the said Constitution.

(2) A person holding office under this section shall, unless the President acting in accordance with the advice of the Prime Minister otherwise permits or allows, vacate his office on attaining the age of sixty-two years.

(3) Subject to the foregoing provisions of this section, any person so appointed to office may be removed only in manner prescribed by the Constitution of the Federation."

**Sections 7 and 8(2)**

*Delete* "Governor-General acting in his discretion" and *substitute* "President acting in accordance with the advice of the Prime Minister"

**Section 10**

*Delete* "Order" and *substitute* "of the Federation"

**Section 17**

In paragraphs (a), (b) and (c) *delete* "Her Majesty's" and *substitute* "the State"

In paragraph (d) *delete* "Her Majesty's" where it secondly occurs and *substitute* "the State"

**Section 22**

*Delete* "Her Majesty's" and *substitute* "the State"

**Section 27**

In subsection (1) *delete* "every native law and custom" and "any such native law or custom" where the expressions respectively occur, and *substitute* "customary law"

In subsection (2) *delete* "Any such law or custom" and *substitute* "Customary law"

In subsection (3) *delete* "native law or custom" where it thrice occurs and *substitute* "customary law"

**Section 28**

Delete "Federal"

**Section 29**

Delete "143 of the Constitution Order" and substitute "125 of the Constitution of the Federation"

**Section 35**

In subsection (4) delete "Federal"

**Section 50, the divisional heading of Part IVA and section 50A** (as inserted by the High Court of Lagos (Amendment) Act 1960 and subsequently renumbered as to sections to accord with the 1958 Edition of the High Court of Lagos Act)

Delete "Federal" where it occurs

**Section 62**

In subsection (1) delete the words "Federal" and "or the Southern Cameroons" where they occur

**Section 67**

Delete "native law or custom" and "that law or custom" where they respectively occur and substitute "customary law"

**Section 81**

Delete where they occur in the subsections—

(a) "Crown" or "crown" and substitute "State" or as the case may require, "state"

(b) "Department" or "department" and substitute "Ministry, department or office"

**Section 83**

In subsection (1) delete "Governor-General" and substitute "Public Service Commission of the Federation"

**Section 89**

In subsection (1) delete "with the approval of the Governor-General"

In paragraph (i) of subsection (1) delete "Federal"

In subsection (2) delete "Crown" and substitute "State"

### HOSPITAL FEES ACT (CAP. 81)

**Section 3**

Renumber this section as subsection (1) and insert the following new subsection—

"(2) The power conferred by the foregoing subsection may, in Lagos, be exercised by the Minister of Health."

**Section 8**

Delete all words after "Lagos" up to the end of the section and substitute "as if it were a Region"

### IKOYI LANDS ACT (CAP. 82)

**Section 5**

Delete "Crown" and substitute "State"

**Section 7**

Renumber this section as subsection (1) and insert a new subsection as follows—

“(2) Lands under this Act which immediately before the date of assumption of republican status for the Federation, were deemed to be Crown Lands shall, with effect from the date of such assumption, be classed as State Lands and may be dealt with accordingly.”

**ILLITERATES PROTECTION ACT**  
(CAP. 83)

**Section 2**

Delete “the Colony and Protectorate” and substitute “Lagos”

**Section 5**

Delete “Federal”

**Section 6**

Delete all words after “apply to” up to the end of the section and substitute “Lagos”

**JURY ACT**  
(CAP. 90)

**Section 1**

In subsection (2) delete all words after “apply to” up to the end of the subsection and substitute “Lagos as if it were a Region”

**Section 2**

Delete “Counsel for the Crown” as words defined, and substitute “Counsel for the State” as words defined

**Section 6**

In the paragraph commencing—

(a) “Such other public officers” delete “Governor-General” and substitute “Public Service Commission of the Federation”

(b) “Officers of” delete from the commencement up to “Force” and substitute “Officers of the Armed Forces of Nigeria and any officers on loan or attached to any of such forces”

(c) “Persons enrolled” delete “Federal”

**Section 7**

Delete “of the High Court”

**Section 33**

In subsection (2) delete “Crown” and substitute “State”

**Section 34**

In paragraph (b) delete “Queen” and substitute “State”

**Sections 35, 42, 43, 44, 45, 46, 48, 49, 51, 66, 68, and 71**

Delete “Crown” where it occurs and substitute “State”

**Section 82**

Delete “Her Majesty’s” and substitute “the”

**Section 88**

In subsection (3) delete “Her Majesty” and substitute “the State”

**Section 89**

Delete “with the approval of the Governor”

**Section 5**

*Delete—*

- (a) "Governor-General" and *substitute* "Minister"
- (b) "Crown" and *substitute* "State"

**Section 7**

In subsection (2) *delete* all words from the commencement up to the proviso thereto, and *substitute* "The Public Service Commission of the Federation may from time to time on such conditions as it thinks fit approve the appointment of any officer under its control to any office under the board."

**Section 10**

In subsection (3) *delete* "Governor-General in Council" and *substitute* "Minister"

**Section 26**

In subsection (5) *delete* the figures "IV" and *substitute* the figures "VI"

**Section 59**

In subsection (3) *delete* "Crown" and *substitute* "State"

**Section 66**

In subsection (1) in paragraph (b) *delete* all words after "authorised" up to the end of the paragraph and *substitute* "or approved by the Federal Minister of Finance"

LAND DEVELOPMENT (PROVISION FOR ROADS) ACT  
(CAP. 97)

**Section 1**

In subsection (1) *insert* at end thereof "and shall apply to the Federal territory"

*Delete* subsection (2)

**Section 2**

(a) *Delete* the definition of district council

(b) In the definition of "prescribed authority" *delete* all words after "Board" up to the end of the definition.

**Section 7**

In subsection (1) *delete* all words after "forwarded" up to the end of the subsection and *substitute* "to the chief federal land officer or to such other officer or authority as the Minister of Lagos Affairs may direct, and another such copy to be deposited in the office of the Lagos City Council."

In subsection (2)—

(a) *delete* "paragraphs (a) to (d) of",

(b) *delete* "Regional", and

(c) in the proviso *delete* "or section 18 of the Nigeria Town and Country Planning Act"

**Sections 8 and 10**

*Delete* all words after "Lagos" up to "may be" and *substitute* "City Council"

**Section 11**

*Delete* all words after "vest" up to the end of the section and *substitute* "in the Lagos City Council"

**Section 14**

*Delete* this section

LAND REGISTRATION  
(CAP. 99)

the words "Crown Grant" as words defined and—  
substitute "State Grant" and  
insert the word "every" in that definition insert "grant heretofore  
is a Crown grant and any"; and  
definition of "local judgment" delete "Federal"

section (1)—

delete "Governor-General shall" and substitute "Public Service  
Commission of the Federation may";

delete "he" and substitute "it"

3  
section (2)—

delete "Crown" and substitute "Nigeria"

in paragraph (b) delete "Royal" where it twice occurs  
section (3) delete all words after "(2) shall be" up to the end of the  
section and substitute "every person having authority to administer an  
any place out of Nigeria"

19

section (2) delete "Crown" and substitute "State or former Crown"

section (2)—

insert immediately after the word "No" the words "State or former",  
delete "a Crown" and substitute "such a"

delete "Crown" where it last occurs and substitute "a"

section (4) delete in the proviso all words following "Region"

1 10

delete the words "of the" and substitute "of the President or of a"

1 14

delete the word "Crown" where it twice occurs and substitute "State"

22

section (1) delete "Governor-General" and substitute "Minister"

section (2) delete "Federal" where it twice occurs

new subsection as follows—

This section shall continue to have effect subject to the provisions  
of section one hundred and twenty of the Constitution of the Federation  
which provides for finality of decisions of the Supreme Court."

24

section (2) delete all words after "Justice" where it first occurs  
"Lagos" where it last occurs and substitute "of Lagos may make  
court for giving effect to sections nineteen, twenty and twenty-  
one of this Act in the High Court or any magistrates' court of Lagos and  
in matters for requiring and regulating the filing in court of maps and  
plans in connection with the title to land in Lagos"

32 and 34

Council" insert "in a Region or the Minister of Lagos Affairs as  
may require,"

6

delete all words after "Lagos" up to the end of the section and substitute  
"in a Region"

LEGITIMACY ACT  
(CAP. 103)

**Section 1**

*Insert at end of the section "and shall apply to the Federal territory"*

**Section 4**

In subsection (1) *delete* "a High Court having jurisdiction" and *substitute* "the High Court"

In subsection (2) *delete* all words after "Justice of" up to "Governor-General" and *substitute* "Lagos"

**Section 5**

In subsection (2) *delete* "native law and custom" and *substitute* "customary law"

**Section 9**

In subsection (1)—

(a) *delete* "in a country, other than Nigeria," and *substitute* "elsewhere than in Nigeria", and

(b) *delete* "in Nigeria" where it occurs thereafter

*Delete* subsection (3)

**Section 10**

In subsection (3) *delete* "native law and custom" and *substitute* "customary law"

LEPROSY ACT  
(CAP. 104)

**Section 3**

In subsection (4)—

(a) *delete* "A Governor may appoint" and *substitute* "There may be appointed", and

(b) *delete* "as he may think"

**Section 6**

In subsection (2) *delete* "native law and custom" and *substitute* "customary law"

**Section 11**

In subsection (1) *delete* "native" and *substitute* "citizen"

In subsection (2) *insert* immediately after "Governor" the words " , or in respect of Lagos, the Minister,"

**Section 21**

*Insert* immediately after "Governor in Council" the words "or as the case may require, the Minister"

**Section 22**

*Delete* "native" where it twice occurs and *substitute* "customary"

**Section 23**

In subsection (3) *delete* "native law and custom" and *substitute* "customary law"

**Section 25**

*Delete* all words after "Lagos" up to the end of the section and *substitute* "as if it were a Region"

LIQUOR ACT  
(CAP. 105)

**Section 2**

In the definition of—

(a) "licensed premises" and "premises" *delete* "sections 54, 57, 58 and" and *substitute* "section"

(b) "trade spirits" *delete* "Act" and *substitute* "and Excise Management Act"

*Delete* the definition "native of a prohibited area"

**Section 3**

- (a) in paragraph (g) *delete* all words after "mess" where it first occurs up to "Force" and *substitute* "in the armed forces of Nigeria"  
 (b) in paragraph (i) *delete* all words after "crews" up to the end of the definition and *substitute* "of ships of the Nigerian Navy under conditions approved by the commodore of the navy;"  
 (c) in paragraph (l) *delete* all words after "members" up to "bona fide" and *substitute* "of the armed forces of Nigeria by any institute or", and  
 (d) *delete* the proviso to this section.

**Section 15**

*Delete* all words after "area" where it first occurs up to "(a)" and *substitute* "from Lagos,"

**Section 63**

*Delete*, "other than an offence under section 57,"

**Section 68**

*Renumber* the section as subsection (1) and *insert* a new subsection as follows—

(2) In respect of Lagos,—

- (a) the reference to "Governor in Council" shall be read as a reference to the Federal Minister of Transport, and  
 (b) the reference to "Governor-General in Council" shall be deleted and there shall be substituted the word "Minister".

**Section 69**

*Delete* all words after "Lagos" up to the end of the section and *substitute* "as if it were a Region"

LUNACY ACT  
(CAP. 112)

**Sections 5 and 19**

*Insert* after "Governor" the words "or in the case of Lagos, the Minister"

**Section 6**

*Delete* "Governor" and *substitute* "appropriate public service commission"

**Section 7**

In subsection (1) *delete* "within the Colony" and *substitute* "appointed for Lagos"

**Section 20**

In subsection (1) *delete* "native" and *substitute* "citizen"

**Section 21**

In subsection (1) *delete* all words after "lunatic is a" up to "custom" and *substitute* "citizen of Nigeria, any community bound by customary law"

**Section 22**

*Delete* this section and *substitute*—

"Removal  
of Lunatics  
out of  
Nigeria

22. Where any person not a citizen of Nigeria is in Lagos adjudged to be a lunatic and the Minister is satisfied that the life of the lunatic may be endangered or his recovery hindered by detaining him in Nigeria, the Minister may report the case to the Federal Minister charged with responsibility for immigration; and if a report is so made the Federal Minister so charged with responsibility may take such action under the Immigration Act 1963 as he thinks fit."

**Section 23**

*Delete* this section

**Section 28**

*Delete* this section

**Section 31**

*Insert* after "Council" the words "or in Lagos the Minister"

**Section 32**

*Delete* all words after "Lagos" up to the end of the section and *substitute* "as if it were a Region"

**The Schedule**

In Form C *delete* "Her Majesty's name" and *substitute* "the name of the State"

In Form D *insert* in the part marked "Statement" immediately following the word "Christian" where it twice occurs the words "or fore"

In Form J *insert* after the word "Governor" where it twice occurs the words "or Federal Minister of Health"

**MAGISTRATES' COURT (LAGOS) ACT**  
(CAP. 113)

**Section 2**

In the definition of—

(a) "Chief Justice", *delete* "of the High Court"

(b) "Constitution Order", *delete* the word "Order" and thereafter *delete* all words therein after "means" and *substitute* "the Constitution of the Federation ; "

(c) "judge", *delete* "of that court"

**Section 4**

In subsection (1) *delete* from the commencement up to "to be" and *substitute* "There may be appointed from time to time by notice in the Gazette such number of"

In subsection (2) *delete* from commencement up to "appoint any" and *substitute* "There may in like manner be appointed from time to time a fit"

**Section 9**

In subsection (1) *delete* "Governor-General" and *substitute* "Minister of Justice"

**Section 11**

*Delete* from the commencement of subsection (1) up to "Governor-General" where it secondly occurs and *substitute*—

"(1) If the Public Service Commission of the Federation considers it expedient so to do it may by notice in the Gazette and for such time as it thinks fit, in any particular case, authorise a person holding office as a justice of the peace to act as a magistrate ; and until the said Commission"

**Section 12**

*Delete* from the commencement up to "may deem" and *substitute* "There may from time to time be appointed as many registrars and other officers as the Public Service Commission of the Federation thinks"

**Sections 14 and 15**

In the respective subsections (1) *delete* "Order"

**Section 17**

*Delete* "Governor-General" where it occurs in the three subsections and *substitute* "Attorney-General"

**Section 22**

In subsection (1) *delete* "every native law and custom" and "such native law and custom" and *substitute* in both cases "customary law"

In subsection (2) *delete* "Any such law or custom" and *substitute* "Customary law"

In subsection (3) *delete* "native law or custom" where it thrice occurs and *substitute* "customary law"

**Section 37**

In subsection (1) *delete* all words after "judgment" up to "Cameroons" and *substitute* "of any court of competent jurisdiction (not being a court martial) superior to every magistrates' court under this Act"

*Add* immediately after subsection (2) the following new subsection—

"(3) For the purposes of this section, the former High Court established for the trust territory of the Southern Cameroons shall in respect of any judgment given by it before its abolition be deemed to have been a court of such superior jurisdiction."

**Section 46** (as amended by the Adaptation of Laws (Miscellaneous Provisions) Order 1960)

*Delete* all words from the commencement up to "any other Act" and *substitute* "Subject to the provisions of the Constitution and of this or any other Act relating to judgments and orders, every judgment and order of the court shall be final"

**Section 56** (as substituted by the Adaptation of Laws (Miscellaneous Provisions) Order 1960)

*Delete* "148 of the Constitution Order" and *substitute* "one hundred and twenty-five of the Constitution of the Federation"

**Section 58** (as amended by the Adaptation of Laws (Miscellaneous Provisions) Order 1960)

In subsection (1) *delete* "148 of the Constitution Order" and *substitute* "one hundred and twenty-five of the Constitution of the Federation"

**Section 75**

*Delete* this section

**Section 76**

*Delete* "Crown" where it occurs in the subsections and *substitute* "State"

**Section 77**

In subsection (1) *delete* "with the approval of the Governor-General"

In subsection (2) *delete* "Crown" and *substitute* "State"

**Section 78**

In paragraph (b) *delete* the word "this" where it secondly occurs in the paragraph

## MONEYLENDERS ACT

(CAP. 124)

**Section 4**

In subsection (2) *insert* immediately following "Council"—

(a) where it first occurs the words "or in the case of Lagos, the Federal Minister of Internal Affairs," and

(b) where it secondly occurs the words "or in the case of Lagos the said Minister"

**Section 31**

*Insert* after the word "Council" the words "or in the case of Lagos the Minister"

**Section 32**

*Delete* all words after "Lagos" and *substitute* "as if it were a Region"

MOTOR VEHICLES (THIRD PARTY INSURANCE) ACT  
(CAP. 126)

**Section 2**

In subsection (1) in the definition of "bankruptcy" *delete* "the United Kingdom or of any British possession" and *substitute* "any part of the Commonwealth"

**Section 5**

In paragraph (a) *delete* all words after "owned by" up to "being used" and *substitute* "the Government of the Federation or if operated in Lagos, of the Government of a Region, while such motor vehicle is used or operated"

*Delete* paragraph (f) (as inserted by the Adaptation of Laws (Cameroons Provisions) Order 1960)

**Sections 19 and 23**

*Delete* "Governor-General in Council" and *substitute* "Minister"

NATIVE LIQUOR (TOWNSHIPS AND CERTAIN AREAS) ACT  
(CAP. 127)

**Section 3**

In subsection (1) *insert* after "Council" the words "or in respect of Lagos, the Minister of Lagos Affairs"

NEWSPAPERS ACT (CAP. 129)

**Section 21**

In subsection (1) *delete* "Governor-General in Council" and *substitute* "Minister"

**Section 23**

*Delete* this section

**SCHEDULE**

*Delete* all words after "bound unto" up to "heirs and" and *substitute* "the President of the Federal Republic of Nigeria in the sum of two hundred and fifty pounds in Nigerian currency to be paid to the President and his"

PAWNBROKERS ACT  
(CAP. 146)

**Section 49**

*Insert* after "Region" where it first occurs the words "or in the case of Lagos, the Minister of Lagos Affairs"

**Section 50**

*Delete* all words after "Lagos" up to the end of the section and *substitute* "as if it were a Region"

PREVENTION OF CRIMES ACT  
(CAP. 157)

**Section 1**

*Delete* all words after "apply to" up to the end of the section and *substitute* "the Federal territory"

**Section 3**

In subsection (2) *delete* "Nigeria" and *substitute* "Lagos."

Governor-General in Council" and substitute "Federal Minister  
with responsibility for police"

## PRINTING PRESSES REGULATION ACT (CAP. 158)

and "and shall apply to the Federal territory"

section (1) delete "Region" and substitute "Federal territory"

section (1) delete "Nigeria" and substitute "Federal territory"

"Governor in Council" and substitute "Minister"

this section

## PRIVATE HOSPITALS ACT (CAP. 160)

2  
definition of "medical officer" delete the words "or by the Principal  
Officer of the Southern Cameroons"

definition of "Regional Director" insert at the end the words ", and  
means the Federal Minister of Health"

13  
number this section as subsection (1) and insert a new subsection as

2) In the application of this section to Lagos, the Minister may make  
provisions after consultation with the Nigeria Medical Council."

14  
delete all words after "Lagos" up to the end of the section and substitute  
"were a Region"

## PROVIDENT FUNDS ACT (CAP. 162)

1  
at end of the section "and shall apply to the Federal territory"

3  
section (1)—  
delete "A Governor in Council" and substitute "The Federal Minister  
with responsibility for provident funds (in this Act referred to as  
"Minister")"

delete "Region" and substitute "Federal territory"  
in paragraph (h) delete "Crown" and substitute "State"

6  
delete "Federal Audit" and substitute "Audit of the Federation"  
delete "Governor, or Minister, as the case may be" and substitute

6  
this section

PUBLIC COLLECTIONS (REGULATION) ACT  
(CAP. 164)

B 519

**Section 1**

*Add at end of the section, "and shall apply to the Federal territory"*

**Section 2**

In subsection (1) *insert* immediately following the definition of "collector" a new definition as follows—  
"Minister" means the Federal Minister of Lagos Affairs ;

**Section 6**

In subsection (1) *delete* all words after "prescribed form" up to "made" and *substitute* "to the Ministry of Lagos Affairs"

*Delete* subsection (2)

In subsection (3)—

(a) *delete* "registration authority" and *substitute* "permanent secretary to the said Ministry, (hereafter in this Act referred to as "the registration authority")"

(b) in paragraph (b) *delete* "in any part of Her Majesty's dominions" and *substitute* "anywhere"

In subsections (4) and (6)—

*delete* "Governor in Council" where it twice occurs in the subsections and *substitute* "Minister"

**Section 12**

*Delete* "Region concerned" and *substitute* "the Federation"

**Section 13**

*Delete* "Governor in Council" and *substitute* "Minister"

**Section 14**

*Delete* this section

PUBLIC HEALTH ACT  
(CAP. 165)

**Section 3**

*Add* immediately after subsection (2) a new subsection as follows—

"(3) In the application of this Act to Lagos, references to a Governor or to a Governor in Council or to a Governor of a Region shall, unless the context otherwise requires be read and construed as references to the Federal Minister of Health."

**Section 34**

*Delete* all words after "administrative officer" up to "authority" and *substitute* "or police officer"

**Section 47**

In subsection (1) in paragraph (b) *delete* all words after "made" up to the end of the paragraph and *substitute* "in the case of Lagos by the city council, may be sued for and enforced in any court of competent jurisdiction."

*Delete* subsection (2)

**Section 55**

*Delete* all words after "Lagos" up to the end of the section and *substitute* "as if it were a Region"

PUBLIC HOLIDAYS  
CAP. (166)

d of the section "and shall apply to the Federal territory"

: words "throughout Nigeria"

Governor-General or Governor as the case may be" and *substitute*  
al Minister charged with responsibility for that department"

his section.

PUBLIC ORDER (LAGOS) ACT  
(CAP. 169)

definition of "Minister" *delete* all words therein after "responsi-  
' and *substitute* "Lagos Affairs"

3  
section (2) *delete* "Crown" and *substitute* "State"

5  
section (1) *delete* "charged with responsibility for Lagos municipal

section (2) *delete* all words after "conferred" up to "municipal affairs"

6  
subsection (1) *delete* in paragraph (a) "the Crown" and *substitute*

7  
subsection (3)—

*delete* "Chief Justice of the High Court" and *substitute* "Chief Justice

*delete* "Crown" and *substitute* "State"

PUBLICATIONS ACT  
(CAP. 171)

*delete* "Nigeria" and *substitute* "the Federal territory"

1  
at end of the section "and shall apply to the Federal territory"

3  
subsection (1)—

*delete* "Nigeria" and *substitute* "the Federal territory",

*delete* "University College, Ibadan" and *substitute* "University of

QUEEN'S GARDENS AND GLOVER HALL  
(CAP. 173)

1  
at end of the section "and shall apply to the Federal territory".  
1A (as inserted by section 2 of Acts No. 40 of 1959)

2  
the definition of "Minister" *delete* all words after "responsibility for"  
the end of the definition and *substitute* "Lagos Affairs"

18

*delete* "Colony" where it twice occurs and *substitute* "Federal territory"

29

subsection (1) *delete* "Governor-General in Council" and *substitute*  
"Minister"

RECOVERY OF PREMISES ACT  
(CAP. 176)

B 521

**Section 1**

In subsection (1) *add* at the end thereof "and shall apply to the Federal territory"

In subsection (2)—

(a) *delete* "Governor in Council" and *substitute* "Minister of Lagos Affairs (hereafter in this Act referred to as "the Minister")"

(b) *delete* "towns, villages, places or",

(c) *delete* "town, village, place or" where the words twice occur.

In subsection (3) *delete* "town, village, place or area by Order in Council" and *substitute* "area by order"

**Section 2**

In the definition of—

(a) "court" *delete* "native" and *substitute* "customary",

(b) "landlord" *delete* "Crown" where it twice occurs and *substitute* "State"

**Section 32**

*Delete* this section.

REGISTRATION OF TITLES ACT  
(CAP. 181)

**Section 1**

*Add* at end of the section "and shall apply to Lagos"

**Section 2**

In subsection (1) *delete* from the commencement up to the end of the first sentence, and *substitute* "The Minister may by order apply this Act to any area in Lagos"

In subsection (2) *delete* from the commencement up to "in Council" where it secondly occurs and *substitute* "The Minister"

**Section 4**

In subsection (1) *delete* all words after "places" up to the end of the subsection and *substitute* "as in Lagos the Minister may direct"

In subsection (3) *delete* all words after "land registry" up to "appoint" where it secondly occurs and *substitute* "there may from time to time be appointed a registrar of titles (in this Act referred to as "the registrar") and there may also be appointed"

In subsection (4) *delete* from the commencement up to "a chief registrar" and *substitute* "There may be appointed"

**Section 7**

*Delete* "Crown" where it twice occurs and *substitute* "State"

**Section 30**

*Delete* "Crown" and *substitute* "State"

**Section 48**

In subsection (1) *delete* "Her Majesty" where it twice occurs and *substitute* "the State"

**Section 50**

*Delete* "Crown" and *substitute* "State"

**Section 51**

In subsection (1) *delete* "Her Majesty" and *substitute* "the State"

**Section 55**

In subsection (3) *delete* "Crown" and *substitute* "State"

**Section 63**

In subsection (1) *delete* "Governor-General or Governor as the case may be" and *substitute* "Attorney-General of the Federation"

**Section 65**

In subsections (1) and (2) *delete* "Director of Surveys or" where it occurs.

**Sections 77 and 78**

*Delete* "Her Majesty" where it occurs and *substitute* "the State"

**Section 78**

*Delete* "Governor-General" where it twice occurs and *substitute* "President"

**Sections 98(6) and 99(3)**

*Delete* "Federal"

**Section 103**

*Delete* all words after "Act" up to "in Council" where it secondly occurs and *substitute* "the Minister".

**First Schedule**

**Forms 1 and 12**

*Delete* the reference to "Crown" where it occurs in the notes and *substitute* "State"

**Forms 1, 3, 8, 9, 10**

*Delete* "Statutory Declarations Act 1835" where the words occur therein and *substitute* "Oaths Act 1963"

RENT RESTRICTION ACT  
(CAP. 183)

**Section 22**

*Delete* this section and *substitute*—  
"Application to Lagos.

22. In the application of this Act to Lagos the Federal territory shall be deemed to be a Region, and references—

(a) to the Governor or a Governor in Council shall be construed as references to the Federal Minister of Lagos Affairs;

(b) to the power for a Chief Justice to make rules shall be construed as a power for the Chief Justice of Lagos to make rules without the need for approval, and section 20 shall be deemed to be amended to the extent necessary and shall have effect accordingly."

ROAD TRAFFIC ACT  
(CAP. 184)

**Section 3**

In subsection (1) in paragraph (b) *delete* "Crown" and *substitute* "State"

**Sections 6A and 9A** (as inserted by the Adaptation of Laws (Cameroons Provisions) Order 1960)

*Delete* "Northern or Southern"

**Section 13**

In subsection (2) *delete* "him by order" and *substitute* "Parliament"

**Section 34**

(a) In subsection (1) in paragraph (n) *delete* "Crown" in subparagraph (iv) and *substitute* "State"

(b) In subsection (2) delete "Governor-General in Council" and substitute "President"

(c) In paragraph (e) of subsection (2) delete "the Governor-General by Order" and substitute "Parliament"

**Section 37**

Delete "Crown" and substitute "State"

**Section 38**

Delete all words after "Lagos" up to the end of the section and substitute "as if it were a Region"

SALE OF FOOD ACT  
(CAP. 185)

**Section 1**

Add at end "and shall apply to the Federal territory"

**Section 2**

In the definition of "analyst" delete "Governor-General" and substitute "Federal Minister of Health"

**Section 7**

Delete "Governor" and substitute "Federal Minister of Health"

SALE OF PRODUCE (TAXATION) ACT  
(CAP. 186)

**Section 4**

Delete "Governor-General in Council" and substitute "Federal Minister charged with responsibility for commerce"

SALES BY AUCTION ACT  
(CAP. 187)

**Section 1**

Delete all words after "apply" up to the end of the section and substitute "to the Federal territory"

**Section 4**

In subsection (1) delete all words after "auctioneer" up to "applies"

**Section 19**

In subsection (1)—

(a) delete all words after "thereof" up to "situated" and substitute "has been given in Lagos", and

(b) delete all words after "prescribed" where it secondly occurs up to "take place" and substitute "as the Minister"

In subsection (2) delete from the commencement up to "notice"

**Section 20**

In subsection (1) delete all words after "shorter time" up to "to take place" and substitute "as the Minister"

Delete subsection (2)

**Section 30**

Delete "Governor in Council" and substitute "Minister"

**Section 31**

Delete this section

ST. SAVIOUR'S CHURCH COUNCIL (INCORPORATION) ACT  
(CAP. 35)

(Formerly the Colonial Church Council (Incorporation) Act)

**Section 2**  
In subsection (3) *delete* "Governor-General of Nigeria" and *substitute* "President"

**Section 11**  
*Delete* all words after "rights" up to "persons" and *substitute* "of the State or any person"

TRADE DISPUTES (ARBITRATION AND INQUIRY) ACT  
(CAP. 201)

**Section 1**

In subsection (1) *insert* at the end of the subsection "and shall apply to Lagos"

In subsection (2) *delete* "Crown" where it twice occurs and *substitute* "State"

**Section 3**

In subsection (3) *delete* all words after "section" up to the end of the subsection and *substitute* "he may inform the Council of Ministers accordingly"

**Section 4**

In subsection (1)—

(a) *delete* "Governor-General" where it twice occurs and *substitute* "Minister"

(b) *delete* all words after "Section 3" up to the end of the subsection and *substitute* "may deal with such trade dispute accordingly."

In subsections (2) and (3) *delete* "Governor-General" where it occurs therein and *substitute* "Minister"

**Sections 7, 8, 9, 10 and 13**

*Delete* "Governor-General" and *substitute* "Minister"

**Section 14**

*Delete* "Governor-General in Council" and *substitute* "Minister"

**Section 15**

In subsection (1) *delete* "Governor-General" where it appears and *substitute* "Minister",

In subsection (2) *delete* "Governor-General" and *substitute* "Public Service Commission of the Federation" and thereafter *delete* "he" and *substitute* "it"

In subsection (3)—

(a) *delete* "Governor-General" where it first occurs and *substitute* "Minister"

(b) *delete* all words after "paid out of" and *substitute* "the Consolidated Revenue Fund."

UNLICENSED GUIDES (PROHIBITION) ACT  
(CAP. 207)

**Section 1**

*Delete* all words after "apply" up to the end of the section and *substitute* "to the Federal territory"

**Section 3**

In subsection (8) in paragraph (b) *delete* "Governor" and *substitute* "Minister"

**Section 13**

*Delete* "In any Region the Governor in Council" and *substitute* "The Minister of Lagos Affairs"

**Section 14***Delete* this sectionVACCINATION ACT  
(CAP. 208)**Section 1***Add* at the end of the section "and shall apply to the Federal territory."**Section 2**In the definition of "medical officer" *delete* all words after "service of" up to the end of the definition and *substitute* "the city council"**Section 3**In subsection (2) *delete* from the commencement up to "think" and *substitute* "There may be appointed such additional persons"**Sections 4 and 5***Delete* "Eastern and Western Regions" where it occurs and *substitute* "Federal territory"**Section 6***Delete* this section**Section 7***Number* the first paragraph as subsection (1) and *delete* from the commencement up to "order each" and *substitute* "The Minister may by order"In subsection (2) *delete* all words after "subsection (1)" up to "Resident" and *substitute* "the Lagos City Council may"In subsection (3) in the proviso *delete* "a native authority or a local government council" and *substitute* "the Lagos City Council"**Sections 8 and 9***Delete* these sections**Sections 10 and 11***Delete* "under section 9,"**Section 12***Delete* "Eastern or Western Region" and *substitute* "Federal territory"**Sections 13, 14 and 15***Delete* these sections**Section 21**(a) *Delete* from the commencement up to "Cameroons" where it secondly occurs and *substitute* "The Minister"(b) *Delete* the proviso to this sectionVENEREAL DISEASES ACT  
(CAP. 209)**Section 1**

In subsection (1)—

(a) *insert* immediately after the short title, the words "shall apply to the Federal territory,"(b) *delete* "Governor-General by notice" and *substitute* "Minister by order"*Delete* subsection (2) and *substitute*—

"(2) The Minister may by the same order appoint different times for the coming into operation of this Act or direct that any section shall apply with such modifications or exceptions as may be specified in the order."

**Section 2**(a) *Insert* in alphabetical sequence the following definition—

"Minister" means the Federal Minister of Health;

(b) In the definition of "medical officer of health" *delete* all words after "Government" up to the end of the definition

**Section 9**

Delete from the commencement up to "Region" and substitute "Where it is reported to the Minister that venereal disease is prevalent among the residents in any part of Lagos and the Minister is satisfied,"

**Section 15**

Delete "A Governor may make rules for his Region" and substitute "The Minister may make regulations"

In paragraph (c) delete "Regional Director of Medical Services" and substitute "Chief Medical Adviser"

**Section 17**

Delete this section

**WILD ANIMALS PRESERVATION ACT**  
(CAP. 221)

**Section 8**

Insert at the commencement "The Minister in respect of Lagos or"

**Section 14**

In subsection (2) insert after "Minister" the words "in respect of Lagos"

**Section 16**

Insert after "shall" the words "in Lagos"

**Sections 18, 19 and 20**

Insert after "Governor in Council" where they occur the words "or in Lagos the Minister"

**Section 22**

In subsection (3) insert after "Governor" the words "or in Lagos, the Minister"

**Section 26**

Delete from the commencement up to "birds" where it first occurs and substitute "Where the Minister is satisfied that it is in the public interest and so he may authorise any person to kill animals or birds in Lagos"

**Section 36**

Delete "native" and substitute "citizen"

**Section 37**

In subsection (1) delete the first sentence and substitute—

"Any person authorised by the Minister may issue in favour of citizens of Nigeria a permit to hunt, kill or capture in Lagos any animal or bird mentioned in the Second Schedule to this Act; and with the approval of the Minister a permit may likewise be so issued in favour of any such citizen to hunt, kill or capture any animal or bird mentioned in the First Schedule".

In subsection (3) delete "Governor" and substitute "Minister".

**Section 42**

In subsection (1) insert after "Council" the words "or in Lagos the Minister"

In subsection (2) delete "Governor-General in Council" and substitute "Minister"

**Section 43**

Delete all words after "Lagos" up to the end of the section and substitute "if it were a Region"

YELLOW FEVER AND INFECTIOUS DISEASES  
(IMMUNISATION) ACT  
(CAP. 224)

**Section 1**

*Add* at end of the section "and shall apply to Lagos."

**Section 2**

In the definition of "health officer" *delete* "Her Majesty's Forces" and *substitute* "the armed forces"

*Delete* the definition of prescribed area

**Section 3**

*Delete* subsection (1)

In subsection (2) *delete* from the commencement up to "Order" and *substitute* "The Minister may by order direct that all persons or any specified classes of persons in or coming into Lagos"

**Sections 4 and 5**

*Delete* "into a prescribed area" where it occurs and *substitute* "Lagos"

**Section 6**

*Delete* all words after "Federation" up to the end of the section and *substitute* "may regulate the procedure whereby adults or children to whom an order under section three of this Act applies shall present themselves or be brought for examination and, if necessary, inoculation."

**Section 7**

*Delete* all words after "Federation" up to the end of the section

**Section 11**

*Delete* from the commencement up to "make rules" and *substitute* "The Minister may, after consultation if he thinks fit, with the chief medical adviser to the Federation make regulations"

**Section 12**

In subsection (1)—

(a) *delete* "Governor-General or a Governor" and *substitute* "President"

(b) *delete* the proviso

In subsection (2) *delete* paragraph (b) and the connecting word "and"

**Section 13**

*Delete* this section

MADE at Lagos this 12th day of September, 1964.

R. C. ONYEJEU,  
*Acting Deputy Secretary to the  
Council of Ministers*

## EXPLANATORY NOTE

*This Note is not part of the Order but is intended to explain its effect*

The amendments made by this order cover the first six volumes of the 1958 Edition of the Laws, those relating to the Federation, or partly to the Federation and partly to the Federal territory, being included in the First Schedule, and others being included in the Second Schedule. They are intended to give effect to changes in the law occasioned by the Constitution of the Federation made since the attainment of independence, and the subsequent adoption of republican status.

It is notified for general information that since the passing of the Designation of Ordinances Act, 1961, all Ordinances whether applicable to the Federation or only to the Federal territory are now known as Acts of Parliament and are to be referred to as such. References to the word "Ordinance" where it still appears in the edition aforesaid should be so construed accordingly.

(904)





L.N. 113 of 1964

IMMIGRATION ACT, 1963  
(1963, No. 6)

**M. Mounir Thomas—Prohibited Immigrants Order, 1964**

WHEREAS as provided under subsection (3) of Section 18 of the Immigration Act, 1963, I am of the opinion that M. MOUNIR THOMAS should be classed as a prohibited immigrant :

NOW THEREFORE in exercise of the powers conferred on me by the said subsection (3) of Section 18 of the Immigration Act, 1963, and of all other powers enabling me in that behalf, I hereby order that the said M. MOUNIR THOMAS be classed as a prohibited immigrant and deported from Nigeria and shall leave on the next available opportunity and remain thereafter out of Nigeria.

MADE in Lagos, this 5th day of October, 1964.

ALHAJI SHEHU SHAGARI,  
*Federal Minister of Internal Affairs*

M.I.A/S. 131/T. 1

L.N. 114 of 1964

MERCHANT SHIPPING ACT, 1962  
(No. 30 OF 1962)

**Merchant Shipping (Declaration of Certificates) Order, 1964**

*Commencement : 10th September, 1964*

In exercise of the powers conferred by section nine of the Merchant Shipping Act, 1962, and of all other powers enabling me in that behalf, I hereby make the following Order—

1. Foreign-going certificates of competency as Master, First Mate, Second Mate and First and Second Class Engineer issued by competent authorities in the countries listed in the Schedule hereto are hereby declared to have the same force as if they are certificates granted under the Merchant Shipping Act, 1962.

2. This Order may be cited as the Merchant Shipping (Declaration of Certificates) Order, 1964.

Declaration in respect of certificates.

Short title.

SCHEDULE

Australia	Canada	Hong Kong
India	Republic of Ireland	Malaysia
New Zealand	Pakistan	

MADE at Lagos this 10th day of September, 1964.

R. A. NJOKU,  
*Minister of Transport*

T1926/II

L.N. 115 of 1964

MERCHANT SHIPPING ACT, 1962  
(1962, No. 30)

Merchant Shipping (Recognition of Schools of Nautical Cookery)  
Regulations, 1964

Commencement : 10th September, 1964

In exercise of the powers conferred by section 427 of the Merchant Shipping Act, 1962, and of all other powers enabling me in that behalf, I hereby make the following regulations—

Short title.

1. These regulations may be cited as the Merchant Shipping (Recognition of Schools of Nautical Cookery) Regulations, 1964.

Recognised  
Schools of  
Nautical  
Cookery.

2. For the purposes of sub-regulation 5 of regulation 2 of the Merchant Shipping (Manning) Regulations, 1963, the following Schools of Nautical Cookery are recognised for the purpose of granting Certificates of Competency as Ship's Cook :

The Robert Gordon's Technical College, Aberdeen.

Grimsby Nautical School, Orwell Street, Grimsby.

Leith Nautical College, 59 Commercial Street, Edinburgh, 6.

City of Liverpool Nautical Training School for Ships' Stewards and Cooks, Oldham Street, Liverpool, 1.

London School of Nautical Cookery, The Sailors' Home and Red Ensign Club, Dock Street and Ensign Street, London, E.1.

National Sea Training Schools of Nautical

Cookery at

.. .. .	..	Cardiff
.. .. .	..	Glasgow
.. .. .	..	Hull
.. .. .	..	South Shields
Royal Naval School of Cookery at	.. ..	Chatham
		Devonport
		Portsmouth
The Army Catering Corps Training Centre	.. ..	Aldershot
The Army Catering Corps Schools	.. ..	British Army of the
		Rhine.
		Middle East Land
		Forces
R.A.F. Catering Centre at	.. ..	Far East Land Forces
		Halton
		Innsworth

3. The Government Inspector of Shipping may by notice recognise other schools for the purpose of granting certificates of competency as a ship's cook and when published in the Gazette the notice of recognition shall have effect as if any such school had been included in these regulations.

MADE at Lagos this 10th day of September, 1964.

R. A. NJOKU,  
Minister of Transport

MERCHANT SHIPPING ACT, 1962  
(1962, No. 30)

**The Merchant Shipping (Marine Boards) Regulations, 1964**

ARRANGEMENT OF REGULATIONS

1. Citation and commencement.
2. Interpretation.
3. Attorney-General to appear for Government.
4. Summoning of Marine Board.
5. Notice of investigation.
6. Parties to the proceedings.
7. Parties by permission.
8. Notice to produce.
9. Notice to admit.
10. Evidence.
11. Proceedings of Board.
12. Addresses and evidence for the parties.
13. Examination of witnesses.
14. Questions for the Board.
15. Addresses.
16. Adjournment.
17. Decision of the Board.
18. Costs.
19. Copy of report.

e-hearing of the case.

ervice of notices.

roof of service.

ssessors allowances.

ublication of regulations.

ODULE—Prescribed Forms.

MERCHANT SHIPPING ACT, 1962  
(1962, No. 30)

The Merchant Shipping (Marine Boards) Regulations, 1964

In exercise of the power conferred by section 427 of the Merchant Shipping Act, 1962, and of all other powers enabling me in that behalf, I hereby make the following regulations—

1. These regulations may be cited as the Merchant Shipping (Marine Boards) Regulations 1964, and shall come into force on the 8th day of October, 1964. Short title and commencement.
2. In these regulations, unless the context otherwise requires—
  - “Attorney-General” means the Attorney-General of the Federation and these regulations ;
  - “Board” means a Marine Board constituted under section 268 of the Act ;
  - “investigation” means a formal investigation into a shipping casualty or into a charge of incompetency or misconduct ;
  - “prescribed fee” means the fee which may be prescribed by regulations made under section 427 (r) of the Act ;
  - “President” means the president of the Marine Board.Interpretation.
3. Every investigation shall be conducted on behalf of the Government by the Attorney-General. Attorney-General to appear for Government.
4. When any investigation has been ordered, the Minister shall summon the Board by summons as in Form 1 in the Schedule and he shall, at the same time, cause notice of the sitting as in Form 2 in the Schedule hereto to be served upon the Attorney-General and upon the owner, master and officers of the ship, and upon any other person who in his opinion ought to be served. Summoning of Marine Board.
- 5.—(1) When an investigation has been ordered, the Attorney-General may cause a notice (hereinafter referred to as “notice of investigation”) to be served upon the persons already served with notices of the sitting and upon any other person who in his opinion ought to be served with such notice. Notice of investigation.
  - (2) The notice of investigation shall contain a statement of the questions which on the information then in the possession of the Attorney-General, he intends to raise on the hearing of the investigation and shall be as in Form 3
  - (3) The Attorney-General may, at any time before the hearing of the investigation, by a subsequent notice amend, add to or omit any of the questions specified in the notice of investigation.
6. The Attorney-General, the owner, the master, and any officer of the ship and any other person upon whom a notice of investigation has been served, shall be deemed to be the parties to the proceedings. Parties to the proceedings.
7. Any other person may, by leave of the President, appear, and any person who appears under this regulation shall thereupon become a party to the proceedings. Parties by permission

party may give to any other party notice in writing to produce any documents relating to the matters in dispute which may be lawfully produced and which are in the possession or under the control of such other party; and, if such notice is not complied with, secondary evidence of the contents of any document may be given by or on behalf of the party who gave such notice.

A party may give to any other party notice in writing to admit any documents; and, in case of neglect or refusal to admit after such notice, the neglecting or refusing shall be liable for all the costs of proving the documents, whatever may be the result, unless the President is of the opinion that the refusal to admit was reasonable; the cost of proving any document shall not be allowed when the notice required by this section has not been complied with, unless the officer by whom the costs are taxed is of the opinion that the failure to give the notice constitutes a saving of expense.

Oaths and affidavits and statutory declarations may, by permission of the President, be used as evidence at the hearing if sworn to or taken in the manner provided by the law of Nigeria.

At the time and place appointed for holding the investigation, the parties may proceed with the investigation whether the parties, upon whom a subpoena of investigation has been served, or any of them, are present or not.

(1) After the question for the opinion of the Board has been stated, the Board shall proceed to hear the parties to the investigation and determine the question so stated.

Each party to the investigation shall be entitled to address the Board, to produce witnesses, or to recall any of the witnesses who have already been examined for further examination, and generally to adduce evidence.

The parties shall be heard and their witnesses examined, cross-examined and re-examined in such order as the President may direct.

The Attorney-General may also produce and examine further witnesses, and may be cross-examined by the parties and re-examined by him.

(1) The proceedings on the investigation shall commence with the production and examination of witnesses by the Attorney-General.

These witnesses, after being examined by or on behalf of the Attorney-General, may be cross-examined by the parties in such order as the President may direct and may then be re-examined by the Attorney-General.

Questions asked and documents tendered as evidence in the course of the examination of these witnesses shall not be open to objection merely on the ground that they do, or may raise questions which are not contained in the statement of the case or questions specified in the subpoena of investigation or subsequent notices referred to in regulation 5.

(2) When the examination of the witnesses produced by the Attorney-General has been concluded, the Attorney-General shall state in an open court before the Board the questions in reference to the casualty, and the conduct of the parties, or other persons connected therewith, upon which the opinion of the Board is desired.

(2) In framing the questions for the opinion of the Board, the Attorney-General may make such modifications, in addition to or omissions from the questions in the notice of investigation or subsequent notices referred to in regulation 5 as, having regard to the evidence which has been given, he may think fit.

15. When the whole of the evidence in relation to the questions for the opinion of the Board has been concluded, any of the parties who desires to do so may address the Board upon the evidence, and the Attorney-General may address the Board in reply upon the whole case. Addresses.

16. The President may adjourn the investigation from time to time and from place to place; where an adjournment is asked for by a party to the investigation or by the Attorney-General, the President may impose such terms as to payment of costs or otherwise as he may think just as a condition of granting such adjournment. Adjournment.

17.—(1) When the certificate of an officer is cancelled or suspended, the decision of the Board to that effect shall always be given in an open session of the Board. Decision of Board.

(2) In other cases, the President may give the decision in an open session of the Board or by serving a copy thereof on the parties.

(3) The decision of the Board shall be in the form of a report as in Form 5 in the Schedule to these Regulations.

(4) This Report shall be sent to the Minister immediately after the conclusion of the investigation.

18.—(1) The President may order that the costs and expenses of the investigation, or any part thereof, shall be paid by the Attorney-General or by any other party. Costs.

19. The Minister shall, if application is made to him therefor, give to any party to the proceedings, a copy of the Board's report, on payment of a prescribed fee. Copy of report.

20. Where the High Court remits a case for re-hearing in accordance with section 271 (1) of the Act, the Minister shall cause such reasonable notice of the remission, as the circumstances of the case may, in his opinion, permit, to be given to the parties whom he considers to be affected thereby. Re-hearing of the case.

21. Any notice, summons or other document issued under these regulations may be served by sending the same by registered letter to the address of the person to be served. Service of notices.

22. The service of any notice, summons or other document may be proved by the oath or affidavit of the person by whom it was served. Proof of service.

23. There shall be paid by the Board to each assessor who is not a member of the Public Service the sum of five pounds for each day of the hearing or a part thereof. Assessors allowances.

24. A copy of these regulations shall be kept at every Ministry, Mercantile Marine and Harbour Masters' Office and any person desiring to peruse them shall be entitled to do so. Publication of regulations.

SCHEDULE  
(Regulations 4, 5 (2), 18 (2) and 19)  
PRESCRIBED FORMS

FORM 1  
(Regulation 4)

SUMMONS TO BOARD

The matter of a formal investigation to be held at.....  
.....into the circumstances attending the.....  
enforcement of the Merchant Shipping Act, 1962 and of the Merchant  
Shipping (Marine Boards) Regulations, 1964, I hereby summon you to  
appear as President (or Member or Scientific referee) on this investigation  
on the..... day of.....  
at..... hour of..... in the..... noon.  
on this..... day of....., 19.....

.....  
*Minister of Transport*

You will attend as summoned.

.....  
*Signature of Person summoned*

FORM 2  
(Regulation 4)

NOTICE OF SITTING OF BOARD

The matter of a formal investigation to be held at.....  
.....the circumstances attending the.....  
.....the Master, Managing  
or Owner of..... shares in the ship,  
.....pellant (or the Attorney-General).  
I hereby give notice that the Board for the above investigation will meet at.....  
.....on the..... day of..... 19.....,  
at..... o'clock in the..... noon to  
discuss the above matter.  
on this..... day of..... 19.....

.....  
*Minister of Transport*

FORM 3  
(Regulation 5 (2))  
NOTICE OF INVESTIGATION

To.....  
Owner, etc., of..... Master, Mate, Engineer, M.E.A.,  
of..... or belonging to the ship

I hereby give you notice that the Minister has ordered a formal investigation into the circumstances attending the..... and the said investigation has been ordered. You are hereby required to produce to the Marine Board all documents relevant to this case which may be in your possession and in particular, the following documents—

I further give you notice that on the information at present available to me, the questions annexed hereto are those upon which it appears desirable, to seek the opinion of the Marine Board; these questions are however subject to alteration, addition, omission or amendment at any time before the hearing of the investigation.

DATED this..... day of..... 19.....

I. Report (or statement of case) *Attorney-General*  
II. Questions.

1. Whether the

(Here insert the proposed questions).

FORM 4  
(Regulation 18 (2))  
ORDER ON A PARTY FOR PAYMENT OF COSTS  
OF INVESTIGATION

In the matter of a formal investigation held at.....  
on the\*..... before..... days of.....  
..... into the circumstances attending the..... assisted by.....

The Board orders—

(1) That..... of.....  
do pay to the Attorney-General the sum of..... on account of  
the expenses of this investigation; or

(2) That the Attorney-General do pay to.....  
of..... the sum of..... on account  
of the expenses of this investigation.

GIVEN under my hand this..... day of..... 19.....

*President*

\* Here state all the days on which the Marine Board sat.

FORM 5  
(Regulation 19)

REPORT OF BOARD

In the matter of a formal investigation held at.....  
 on the\*..... day of  
 before.....  
 assisted by..... into the circumstances  
 attending the.....

The Marine Board, having carefully inquired into the circumstances attending the above-mentioned shipping casualty, finds, for the reasons stated in the Annex hereto, that the (here state finding of the Board).

DATED this.....day of....., 19.....

*President*

I do/do not† concur in the above report.

Member.  
 Member.  
 Member.  
 Member.

ANNEX TO THE REPORT

*(Here state fully the circumstances of the case, the opinion of the Marine Board touching the causes of the casualty, and the conduct of any persons implicated therein, and whether the certificate of any officer is either suspended or cancelled, and if so for what reasons).*

MADE at Lagos this 8th day of October, 1964.

R. A. NJOKU,  
*Federal Minister of Transport*

EXPLANATORY NOTE

These regulations prescribe the Rules of Procedure to be followed by a Marine Board when making investigations as to casualties affecting ships or of charges of incompetency or misconduct on the part of officers of ships.

\* Here state all the days on which the Marine Board sat.

† If a Member does not concur in the report his reasons for dissenting therefrom shall be annexed to the report.

Supplement to Official Gazette No. 85, Vol. 51, 15th October, 1964—Part B

L.N. 117 of 1964

LABOUR CODE ACT (CHAPTER 91)

The Labour Code (Trade Union Contributions) Order, 1962

Commencement : 1st August, 1964

In exercise of the powers conferred by subsection (2) of section 27A of the Labour Code Act, and of all other powers enabling me in that behalf, I hereby make the following Order :—

1. This Order may be cited as the Labour Code (Trade Union Contributions) Order, 1964, and shall be of Federal application.
2. The trade union specified in the first column of the Schedule is hereby approved for the purpose of subsection (1) of section 27A of the Labour Code Act with effect from the date specified in the second column of the Schedule.

Citation and application.

Trade Unions approved by Minister pursuant to section 27A (a), Cap. 91 Schedule.

Section 2

SCHEDULE

Name of Trade Union	Date
Union of Messengers, Lagos .. .. .	1-8-64
X-Ray Technical Staff Union .. .. .	1-8-64
Bank of West Africa African Workers' Union .. .. .	1-8-64

DATED at Lagos this 24th day of July, 1964.

J. M. JOHNSON,  
Federal Minister of Labour

L.N. 118 of 1964

EXCISE (CONTROL OF DISTILLATION) ACT, 1964  
(1964, No. 22)

Excise (Control of Distillation) Act (Appointed Day) Order, 1964

In exercise of the powers conferred by subsection (2) of section 28 of the Excise (Control of Distillation) Act, 1964, and of all other powers enabling me in that behalf, I hereby make the following Order—

1. The Excise (Control of Distillation) Act, 1964 shall be deemed to have come into force on the 1st day of April, 1964.
2. This Order may be cited as the Excise (Control of Distillation) Act (Appointed Day) Order, 1964.

Commencement.

Citation.

DATED this 18th day of September, 1964.

FESTUS S. OKOTIE-EBOH,  
Federal Minister of Finance

19 of 1964

**LAGOS TOWN PLANNING (COMPENSATION) ACT, 1964**  
(1964, No. I)

**Lagos Town Planning (Compensation) Act (Appointed Day)  
Order, 1964**

*Commencement : 15th October, 1964*

exercise of the powers conferred by subsection (2) of section 2 of the  
Lagos Town Planning (Compensation) Act, 1964 and of all other powers  
enabling him in that behalf, the President had made the following order—

1. The Lagos Town Planning (Compensation) Act, 1964 shall come into  
force on 15th October, 1964.

2. This Order may be cited as the Lagos Town Planning (Compensation)  
Order, (Appointed Day) Order, 1964.

MADE this 14th day of October, 1964.

R. C. ONYEJEPU,  
*Acting Deputy Secretary to the  
Council of Ministers*

# EVIDENCE (AMENDMENT) ACT, 1964



1964, No. 24

AN ACT TO AMEND THE EVIDENCE ACT AS TO CERTAIN CERTIFICATES IN CRIMINAL CASES.

[12th October, 1964]

Commence-  
ment.

BE IT ENACTED by the Legislature of the Federation of Nigeria in this present Parliament assembled and by the authority of the same as follows :—

1.—Where a certificate purports to be signed by an officer of the Central Bank of Nigeria who himself adds after his signature the words "duly authorised by the Governor of the Central Bank of Nigeria for the purposes of section forty-one of the Evidence Act" it shall be accepted by all courts and persons as sufficient evidence of the facts stated in the certificate, and no certificate shall be questioned on the ground only of the authorisation ; but subject thereto, the proviso to subsection (1) of section forty-one of the Evidence Act shall have effect with regard to any such certificate.

Certificat  
of Centra  
Bank offi  
as eviden  
in crim  
cases.

Cap. 6

2.—(1) This Act may be cited as the Evidence (Amendment) Act, 1964 and shall be read as one with the Evidence Act.

Short  
repeal  
opera  
Cap.

(2) The Evidence (Amendment) Act, 1960 is hereby repealed.

(3) This Act shall apply throughout the Federation.

No.  
1966



## SURVEY ACT, 1964



1964, No. 25

AN ACT TO ALTER THE CONSTITUTION OF THE SURVEYORS LICENSING BOARD AND THE QUALIFICATIONS REQUIRED FOR THE ISSUE OF A SURVEYOR'S LICENCE; AND FOR PURPOSES CONNECTED WITH THE MATTERS AFORESAID.

[12th October, 1964]

Commence-  
ment.

BE IT ENACTED by the Legislature of the Federation of Nigeria in this present Parliament assembled and by the authority of the same as follows:—

1.—(1) The Surveyors Licensing Board (hereafter in this section referred to as "the board") shall, instead of being constituted as provided by section three of the Survey Act, be constituted in accordance with the following provisions of this section; and accordingly the provisions of that section from the words "consisting of" onwards are hereby repealed.

Alteration  
of constitu-  
tion of  
Surveyors  
Licensing  
Board.

Cap. 194.

(2) The board shall consist of the following members, that is to say,—

(a) the Director of Federal Surveys, who shall be the chairman of the board;

(b) the Surveyor-General of each Region or a licensed surveyor nominated by him; and

(c) three licensed surveyors of whom—

(i) two shall be appointed by such body as the Minister may designate as being in his opinion representative of licensed surveyors in Nigeria; and

(ii) the other shall be appointed by the Minister and shall be a person appearing to the Minister to be engaged in the training, at a university or school of survey in Nigeria, of persons seeking to become surveyors.

(3) A person appointed as a member of the board by virtue of paragraph (c) above—

(a) may resign his office by notice in writing to the Minister ;

(b) may be removed from office by the Minister for misbehaviour or for inability to perform the functions of his office ;

(c) shall, unless he previously resigns or is removed from office, hold office for such period not exceeding three years as may be specified in his instrument of appointment ; and

(d) shall, on ceasing to hold office, be eligible for re-appointment.

(4) The quorum of the board shall be three, and the validity of any proceedings of the board shall not be affected by any vacancy in the membership of the board or by any defect in the appointment of a member.

(5) For the avoidance of doubt it is hereby declared that any person (other than the Director of Federal Surveys) who is a member of the board immediately before the day when this Act comes into force shall cease to be such a member on that day.

(6) In this section "licensed surveyor" has the same meaning as in the Survey Act.

2. No surveyor's licence shall be granted after the commencement of this Act by virtue of paragraph (c) of section five of the Survey Act (which authorises the grant of such a licence in certain circumstances to a person who has completed fifteen years service as a surveyor in the said paragraph (c) is hereby repealed.

3. This Act may be cited as the Survey Act, 1964, and shall apply throughout the Federation.

Abolition of power to license as surveyors persons qualified only by experience in public departments.

Short title and extent.

# PHARMACISTS ACT, 1964



## ARRANGEMENT OF SECTIONS

### *Section*

#### *The Pharmacists Board of Nigeria*

1. Establishment of Pharmacists Board
2. Financial provisions.
3. Control of board by the Minister.

#### *The Register*

4. Appointment of registrar and preparation etc. of registers.
5. Publication of registers and lists of corrections.

#### *Registration*

6. Examination qualifications.
7. Registration of pharmaceutical chemists
8. Approval of courses, qualifications and institutions.
9. Supervision of instruction and examinations leading to approved qualification.

#### *Professional discipline*

10. Establishment of disciplinary committee and investigating panel.

### *Miscellaneous and general*

11. Penalties for unprofessional conduct, etc.
12. Offences.
13. Employment in the public service or the armed forces.
14. Miscellaneous supplementary provisions.
15. Regulations, rules and orders.
16. Transitional provisions and repeals.
17. Change of title of Pharmacy Act.
18. Interpretation, etc.
19. Short title, extent and commencement.

### *Schedules*

1. Supplementary provisions relating to the pharmacists board.
2. Supplementary provisions relating to the disciplinary committee and investigating panel.
3. Enactment repealed and enactment amended.
4. Enactment affected.



## 1964, No. 26

AN ACT TO MAKE BETTER PROVISION FOR THE REGULATION OF PHARMACEUTICAL CHEMISTS AND FOR PURPOSES CONNECTED THEREWITH: AND TO AMEND CONSEQUENTIALLY THE PHARMACY ACT.

BE IT ENACTED by the Legislature of the Federation of Nigeria in this present Parliament assembled and by the authority of the same as follows:—

[Section 19(2)]

Commencement.

*The Pharmacists Board of Nigeria*

1.—(1) There shall be established a body to be known as the Pharmacists Board of Nigeria (in this Act referred to as "the board") which under that name shall be a body corporate with perpetual succession and a common seal and be charged with the general duty of—

Establishment of Pharmacists Board.

(a) determining what standards of knowledge and skill are to be attained by persons seeking to become pharmaceutical chemists (in this Act referred to as "pharmacists") and raising those standards from time to time as circumstances may permit;

(b) securing in accordance with the provisions of this Act the establishment and maintenance of—

(i) a register of pharmacists, and

(ii) a register to be known as "the provisional register" of such other persons as the board may recognise for the purposes of this Act,

and thereafter securing the publication from time to time by the secretary to the board of lists of those persons whose names are entered in such registers; and

(c) performing the other functions conferred on the board by this Act.

(2) Subject to the provisions of this Act, the board shall consist of a chairman and members appointed by the Minister and shall comprise,—

(a) the chief pharmacist of the Federal Ministry of Health who shall be chairman; and

(b) the following persons, namely,—

(i) the president of the Pharmaceutical Society of Nigeria,

(ii) the chief pharmacist or as the case may be, the principal pharmacist in each Region,

(iii) the heads of pharmacy sections of institutions in Nigeria approved by the board,

(iv) one member nominated by the council of the pharmaceutical society of Nigeria,

(v) one member from each Region and one member from the Federal territory nominated from those territories by the respective branches of the pharmaceutical society of Nigeria after consultation with the Minister.

(3) The provisions of the First Schedule to this Act shall have effect with respect to the qualifications and tenure of office of members of the board, and of the powers and procedure of the board and other matters there mentioned.

(4) Regulations may provide for increasing or reducing the membership of the board.

2.—(1) The board shall prepare and submit to the Minister, not later than the first day of September of the year in which this subsection comes into force and of each subsequent year, an estimate of its expenditure and income during the next succeeding financial year.

(2) The board shall keep proper accounts in respect of each financial year, and proper records in relation to those accounts, and shall cause its accounts to be audited as soon as may be after the end of the financial year to which the accounts relate by a firm of auditors approved, in respect of that year, by the Minister of the government of the Federation responsible for finance.

(3) The Minister may, out of moneys provided by Parliament, make to the board either by way of grant or by way of loan, payments of such amounts as Parliament may from time to time determine.

3.—(1) The Minister may give to the board directions of a general character or relating generally to particular matters (but not to any individual person or case) with regard to the exercise by the board of its functions, and it shall be the duty of the board to comply with the directions.

(2) Before giving a direction under subsection (1) of this section, the Minister shall serve a copy of the proposed direction on the board and shall afford the board an opportunity of making representations to him with respect to the direction; and after considering any representations made to him in pursuance of this subsection the Minister may give direction either without modification or with such modifications as appear to him to be appropriate having regard to the representations.

#### *The Register*

4.—(1) There shall, on the recommendation of the board be appointed as registrar of the board a fit person who shall be a pharmaceutical chemist in the employ of the Public Service of the Federation: Provided that the registrar may also be the secretary with the approval of the Minister.

(2) There may likewise be so appointed a deputy registrar and such other officers and employees as may from time to time be necessary for the purposes of this Act.

(3) The registrar shall in accordance with rules made by the board under this section, prepare and maintain a register of the names, addresses and approved qualifications and of such other particulars as may be specified of all persons who are entitled to be registered under this Act who apply in the specified manner to be so registered.

(4) Subject to the following provisions of this section, the board shall make rules with respect to the form and keeping of the registers and the making of entries therein, and in particular—

(a) regulating the making of applications for registration and providing for the evidence to be produced in support of applications;

(b) providing for the notification to the registrar, by the person to whom any registered particulars relate, of any change in those particulars;

(c) specifying the fees to be paid to the board in respect of the entry of names on the registers and authorising the registrar to refuse to enter a name on a register until any fee specified for the entry has been paid;

(d) specifying anything falling to be specified under the foregoing provisions of this section;

but rules made for the purposes of paragraph (d) of this subsection shall not come into force until they are confirmed by order of the Minister.

(5) It shall be the duty of the registrar—

(a) to correct, in accordance with the directions of the board, any entry in a register which the board directs him to correct as being in the opinion of the board an entry which was incorrectly made;

(b) to make from time to time any necessary alterations in the registered particulars of registered persons; and

(c) to remove from the relevant register the name of any registered person who has died, or unless exempted fails after the expiration of one year to pay a retention fee under this Act.

(6) If the registrar—

(a) sends by post to any registered person a registered letter addressed to him at his address on the register enquiring whether the registered particulars relating to him are correct and receives no reply to the letter within the period of six months from the date of posting it; and

(b) upon the expiration of that period sends in like manner to the person in question a second similar letter and receives no reply to that letter within three months from the date of posting it,

the registrar may remove the particulars relating to the person in question from the relevant register; and the board may direct the registrar to restore to the appropriate register any particulars removed therefrom under this subsection.

5.—(1) It shall be the duty of the registrar—

(a) to cause the registers to be printed, published and put on sale to members of the public not later than two years from the beginning of the year in which this section comes into force; and

(b) in each year after that in which a register is first published under paragraph (a) of this subsection to cause to be printed, published and put on sale as aforesaid a corrected edition of the registers or as the board thinks fit a list of corrections made to the registers since they were last printed; and

;) to cause a print of each edition of the registers and of the list of corrections to be deposited at the principal office or offices, as the case may be, of the board ;

shall be the duty of the board to keep the registers and lists so deposited open at all reasonable times for inspection by members of the public.

(2) A document purporting to be a print of an edition of a register issued under this section by authority of the registrar in the current year or documents purporting to be prints of an edition of a register so issued in a previous year and of a list of corrections to that edition published in the current year shall, as an alternative to any other mode of proof in any proceeding be admissible as evidence that any person specified in the document or in the documents if read together, is registered under this Act—

(a) is so registered, or

(b) is so registered subject to payment of the annual retention fee ; and that if not specified in the registers he is not so registered.

(3) The registers shall show in an appropriately headed column the annual licence fee was last paid by each person appearing as registered therein, unless exempted under this Act.

Registration

6.—(1) The board shall from time to time arrange for the examination of candidates as pharmacists and for the issue of diplomas under the provisions of this Act ; and for such purpose the board may prescribe the fees and appoint examiners from time to time at such remuneration as the Minister may approve.

(2) The board may exempt any person from the requirements of this section under this section either wholly or in part where it is satisfied that such person is the holder of a diploma issued by any authority outside Nigeria ; and if such holder is not a citizen of Nigeria, he shall, in addition, satisfy the board that he has been resident in Nigeria for not less than twelve months immediately preceding the date of application for exemption.

(3) A diploma issued under this section shall show that the person named therein is qualified to apply for registration as a pharmacist ; and if an applicant is thereafter so registered under this Act he shall, on payment of the prescribed fee, be entitled to an annual licence to practise as a pharmacist accordingly.

7.—(1) An applicant for registration shall unless otherwise precluded by this Act, be entitled to be registered as a pharmacist if he satisfies the

(a) that he is of good character, and is the holder of—

(i) a diploma under this Act, or

(ii) a qualification granted outside Nigeria and for the time being accepted by the board for the purpose of this subsection ;

and (b) if the board so requires, that he has had sufficient practical experience as a pharmacist.

(2) Any person aggrieved by a decision of the Board under this section may appeal to the Minister within one month after notice is given to him of the decision.

(3) For the purposes of this section, the board shall from time to time publish in the gazette particulars of the qualifications for the time being accepted by the board.

8.—(1) The board may approve—

(a) any course of training which is intended for persons who are seeking to become, or are already, pharmacists and which the board considers is designed to confer on persons completing it sufficient knowledge and skill for the practice of that profession;

(b) any institutions, either in Nigeria or elsewhere, which the board considers is properly organised and equipped for conducting the whole or any part of a course of training approved by the board under this section;

(c) any qualification which, as a result of an examination taken in conjunction with a course of training approved by the board under this section, is granted to candidates reaching a standard at the examination indicating, in the opinion of the board, that they have sufficient knowledge and skill to practise the profession of a pharmacist.

(2) The board may, if it thinks fit, withdraw any approval given under this section in respect of any course, qualification or institution; but before withdrawing such an approval the board shall—

(a) give notice that it proposes to do so to each person in Nigeria appearing to the board to be a person by whom the course is conducted or the qualification is granted or the institution is controlled, as the case may be; and

(b) afford each such person an opportunity of making to the board representations with regard to the proposal; and

(c) take into consideration any representations made as respects the proposal in pursuance of the last foregoing paragraph.

(3) As respects any period during which the approval of the board under this section for a course, qualification or institution is withdrawn, the course, qualification or institution shall not be treated as approved under this section; but the withdrawal of such an approval shall not prejudice the registration or eligibility for registration of any person who by virtue of the approval was registered or eligible for registration immediately before the approval was withdrawn.

(4) The giving or withdrawal of an approval under this section shall have effect from such date, either before or after the execution of the instrument signifying the giving or withdrawal of the approval, as the board may specify in that instrument; and the board shall—

(a) as soon as may be publish a copy of every such instrument in the gazette; and

(b) not later than seven days before its publication as aforesaid, send a copy of the instrument to the Minister.

9.—(1) It shall be the duty of the board to keep itself informed of the nature of the instruction given at approved institutions to and examinations taken by persons attending approved courses of training and for the purposes of performing that duty the board may appoint, either from among its own members or otherwise, persons to visit approved institutions or to attend such examinations.

Approval of  
courses,  
qualifica-  
tions and  
institutions.

Supervision  
of instructor  
and examina-  
tions leading  
to approved  
qualification

(2) It shall be the duty of a visitor appointed under this subsection report to the board on—

- (a) the sufficiency of the instruction given to persons attending approved courses of training at institutions visited by him ;
  - (b) the sufficiency of any examinations attended by him ; and
  - (c) any other matters relating to the institutions or examinations on which the board may, either generally or in a particular case, request him to report ;
- but no visitor shall interfere with the giving of any instruction or the holding of any examination.

(3) On receiving a report made in pursuance of this section, the board shall as soon as may be send a copy of the report to the person appearing to the board to be in charge of the institution or responsible for the examinations to which the report relates requesting that person to make observations on the report to the board within such period as may be specified in the request, not being less than one month beginning with the date of the request.

### Professional Discipline

10.—(1) There shall be a committee to be known as the Pharmacists Disciplinary Committee (in this Act hereafter referred to as the "disciplinary committee") which shall be charged with the duty of considering and determining any case referred to it by the panel established by the following provisions of this section, and any other case of which the disciplinary committee has cognisance under the following provisions of this Act.

(2) The disciplinary committee shall consist of the chairman of the board and eleven other members of the board appointed by the board and shall include not less than five members of the board holding office by virtue of sub-paragraphs (iv) and (v) of paragraph (b) of sub-section (2) of section one of this Act, or where the number of those members is for the time being less than five, all those members.

(3) There shall be a body, to be known as the Pharmacists Investigating Panel (in this Act hereafter referred to as "the panel"), which shall be charged with the duty of—

(a) conducting a preliminary investigation into any case where it is alleged that a registered person has misbehaved in his capacity as a pharmacist or should, for any other reason be the subject of proceedings before the tribunal ; and

(b) deciding whether the case should be referred to the tribunal.

(4) The panel shall consist of five members to be appointed by the board and shall include one qualified in law to be appointed on the recommendation of the Attorney-General of the Federation ; and the Registrar shall be the secretary of the panel, but shall not have a vote.

(5) The provisions of the Second Schedule to this Act shall, in so far as applicable to the disciplinary committee and the panel respectively, have effect with respect to those bodies.

*Miscellaneous and General*

## 11.—(1) Where—

(a) a registered person is judged by the disciplinary committee to be guilty of infamous conduct in any professional respect ; or

(b) a registered person is convicted, by any court in Nigeria or elsewhere having power to award imprisonment, of an offence (whether or not an offence punishable with imprisonment) which in the opinion of the disciplinary committee is incompatible with the status of a pharmacist ; or

(c) the disciplinary committee is satisfied that the name of any person has been fraudulently registered, the disciplinary committee may, if it think fit, give a direction reprimanding that person or ordering the registrar to strike his name off the relevant register or registers.

Penalties for unprofessional conduct, etc.

(2) The disciplinary committee may, if it thinks fit, defer or further defer its decision as to the giving of a direction under the foregoing subsection until a subsequent meeting of the disciplinary committee ; but—

(a) no decision shall be deferred under this subsection for periods exceeding two years in the aggregate ; and

(b) no person shall be a member of the disciplinary committee for the purposes of reaching a decision which has been deferred or further deferred unless he was present as a member of the disciplinary committee when the decision was deferred.

(3) For the purposes of subsection (1) of this section a person shall not be treated as convicted as mentioned in paragraph (b) of that subsection unless the conviction stands at a time when no appeal or further appeal is pending or may (without extension of time) be brought in connection with the conviction.

(4) When the disciplinary committee gives a direction under subsection (1) of this section, the disciplinary committee shall cause notice of the direction to be served on the person to whom it relates.

(5) The person to whom such a direction relates may, at any time within twenty-eight days from the date of service on him of the notice of the direction, appeal against the direction to the Supreme Court ; and the disciplinary committee may appear as respondent to the appeal and, for the purpose of enabling directions to be given as to the costs of the appeal and of proceedings before the disciplinary committee, shall be deemed to be a party thereto whether or not it appears on the hearing of the appeal.

(6) A direction of the disciplinary committee under subsection (1) of this section shall take effect—

(a) where no appeal under this section is brought against the direction within the time limited for the appeal, on the expiration of that time ;

(b) where such an appeal is brought and is withdrawn or struck out for want of prosecution, on the withdrawal or striking out of the appeal ;

(c) where such an appeal is brought and is not withdrawn or struck out as aforesaid, if and when the appeal is dismissed ; and shall not take effect except in accordance with the foregoing provisions of this subsection.

(7) A person whose name is removed from a register in pursuance of a direction of the disciplinary committee under this section shall not be entitled to be registered in that register again except in pursuance of a direction in that behalf given by the disciplinary committee on the application of that person ; and a direction under this section for the removal of a person's name from a register may prohibit an application under this subsection by that person until the expiration of such period from the date of the direction (and where he has duly made such an application, from the date of his last application) as may be specified in the direction.

12.—(1) Unless otherwise exempted under this Act, any person, not being a fully registered pharmacist or, being a fully registered pharmacist and allowing his licence to expire so that payment of the prescribed fee is in arrears for more than one year, who—

(a) for or in expectation of reward practises or holds himself out as a pharmacist ; or

(b) takes or uses any letters after his name to indicate qualification as a pharmaceutical chemist ; or

(c) without reasonable excuse takes or uses any name, title, addition or description implying that he is authorised by law to practise as a pharmacist,

shall be guilty of an offence.

(2) If any person, for the purpose of procuring the registration of any name, qualification or other matter—

(a) makes a statement which he believes to be false in a material particular ; or

(b) recklessly makes a statement which is false in a material particular,

he shall be guilty of an offence.

(3) If the registrar or any other person employed by the board wilfully makes any falsification in any matter relating to the register he shall be guilty of an offence.

(4) A person guilty of an offence under this section shall be liable—

(a) on summary conviction, to a fine not exceeding fifty pounds ;

(b) on conviction on indictment, to a fine not exceeding five hundred pounds or imprisonment for a term not exceeding two years or to both.

(5) Where an offence under this section which has been committed by a body corporate is proved to have been committed with the consent or connivance of, or to be attributable to any neglect on the part of, any director, manager, secretary or other similar officer of the body corporate, or any person purporting to act in any such capacity, he, as well as the body corporate, shall be deemed to be guilty of that offence and shall be liable to be proceeded against and punished accordingly.

13.—(1) A person shall not hold an appointment as a pharmacist in the public service of the Federation or of a Region or in the armed forces of the Federation unless—

Employment in the public service or the armed forces.

(a) he is the holder of an annual licence to practise as a pharmacist ; or

(b) he is, as the holder of a diploma granted by the board or of some other approved qualification, exempted from the requirement of an annual licence fee.

(2) The Minister may by order in the gazette exempt any class or classes of persons from the requirements of this Act as to annual licences for such period or periods as he thinks fit ; and may at any time amend, vary or revoke any such notice.

14.—(1) A fully registered pharmacist shall be entitled to practise as a pharmaceutical chemist throughout the Federation.

Miscellaneous supplementary provisions.

(2) Without prejudice to the rule of law whereby a contract may be void if it is inconsistent with the provisions of an enactment, no person other than a fully registered pharmacist shall be entitled to bring any proceedings in any court of law for the purpose of recovering any fee or other consideration whatsoever payable in respect of services rendered or facilities or things supplied by him when purporting to act as a pharmaceutical chemist.

(3) It shall be the duty of the person in charge of each school of pharmacy, university or similar institution in the Federation at which there is held a course of training intended for persons who are seeking to become members of the pharmaceutical profession to furnish to the registrar, not later than the thirty-first day of March in every year, a list of the names, and of such other particulars as the board may by order specify, of all persons who attended any such course at the institution in question at any time during the preceding year.

15.—(1) Any power to make regulations, rules or orders conferred by this Act shall include power—

Regulations, rules and orders.

(a) to make provision for such incidental and supplementary matters as the authority making the instrument considers expedient for the purposes of the instrument ; and

(b) to prescribe membership fees in such amount as the Minister may from time to time approve ; and

(c) to make different provision for different circumstances.

(2) The Minister shall lay a copy of all regulations before each House of Parliament as soon as may be after the regulations are made.

16.—(1) A person whose name is not on the register maintained under the Pharmacy Act by reason of its having been removed by order of the Pharmacy Board under that Act shall be deemed for the purposes of this Act to have had his name removed, in pursuance of a direction of the disciplinary committee which took effect on the date when this subsection came into force, from the register maintained under this Act ; and the provisions of subsection (7) of section eleven of this Act shall have effect accordingly as if the direction aforesaid prohibited applications under that subsection for the period of six months.

Transition provision and repe: Cap. 152

(2) Any proceedings under the Pharmacy Act which, immediately before the date when the provisions of that Act relating to such proceedings are repealed, were pending before the Pharmacy Board established by that Act or before the Minister or in any court on appeal may be continued, and any right of appeal under that Act which was exercisable immediately before that date may be exercised, as if this Act had not been passed; and for the purposes of the foregoing provisions of this section and of enabling effect to be given to any order made or judgment given in connection with any such proceedings or appeal, but not for any other purposes, the register maintained under that Act shall be deemed not to be abolished.

(3) The provisions of the Pharmacy Act shall—

(a) be repealed on such date as the Minister may by order appoint to the extent set out in Part A of the Third Schedule to this Act, and different dates may be appointed in relation to different provisions thereof, and

(b) to the extent to which that Act, as affected by this Act, thereafter continues in force in its application to the Federation or to the Federal territory, as the case may be, it shall have effect subject to the amendments set out in Part B of that Schedule, and to the provisions of the next succeeding section;

and subject to the provisions of subsection (2) of this section, the register maintained under the said Pharmacy Act shall be abolished.

17. So much of the Pharmacy Act as is not repealed by this Act may, on the commencement of this Act, be cited as the Poisons and Pharmacy Act, and accordingly—

(a) in the long title, all words after "poisons" up to the end of the long title in its application to the Federation shall be repealed; and

(b) in section one thereof there shall be substituted for all words after "cited" up to the end of the section, the words "as the Poisons and Pharmacy Act.";

and that Act shall have effect to the extent mentioned in section nineteen and set out in the Fourth Schedule to this Act.

18.—(1) In this Act, unless the context otherwise requires, the following expressions have the meanings hereby assigned to them respectively, that is to say—

"approved" means for the time being approved under this Act;

"approved qualifications" means a qualification which is approved in respect of the pharmaceutical profession;

"the board" means the Pharmacists Board of Nigeria;

"the disciplinary committee" means the Pharmacists Disciplinary Committee under section ten of this Act;

"gazette" means the Gazette of the Federation;

"the Minister" means the Minister of the government of the Federation responsible for matters relating to health;

"the panel" has the meaning assigned to it by section ten of this Act;

"pharmacist" means a pharmaceutical chemist registered and permitted to practise as such under this Act;

"prescribed" means prescribed by regulations;

Change of  
title of  
Pharmacy  
Act.  
Cap. 152.

Interpreta-  
tion, etc.

"register" means a register maintained under this Act, and "registered" shall be construed accordingly;

"the registrar" means the registrar appointed in pursuance of section four of this Act;

"regulations" means regulations made by the Minister.

(2) For the purposes of this Act—

(a) a person is fully registered if his name is for the time being entered in the register other than the provisional register; and

(b) a person whose name is in the provisional register is one whose qualifications as a pharmacist are provisionally recognised by the board and are subject to the provisions of this Act and regulations made thereunder, and "registered" shall be construed in accordance with paragraphs (a) and (b) of this subsection.

(3) Any approval, consent, direction, notice, observations, report, representation or request authorised or required to be given or made by or under this Act shall be in writing and may, without prejudice to any other method of service but subject to the provisions of rules made under the Second Schedule to this Act, be served by post.

19.—(1) This Act may be cited as the Pharmacists Act, 1964, and the Fourth Schedule shall, save as to subsection (1) of section forty-nine and subsection (1) of section sixty-nine of the Act there cited, have effect in the Federal territory.

Short title, extent and commencement.

(2) The provisions of this Act shall come into force on such date as the Minister may by order appoint, and different dates may be appointed for the purposes of different provisions.

## SCHEDULES

### FIRST SCHEDULE

Section 1 (4)

#### SUPPLEMENTARY PROVISIONS RELATING TO THE PHARMACISTS BOARD

##### *Qualifications and tenure of office of members*

1.—(1) A person shall not be a member of the board unless he is a pharmaceutical chemist.

(2) Members other than those appointed by office shall hold office for a period of three years beginning with the date of his appointment as a member, but shall be eligible for reappointment at the expiration of that period.

(3) Any member other than a member appointed by office may at any time resign his appointment by notice in writing under his hand; and the resignation shall have effect upon signification by any means of its acceptance by the Minister.

(4) Members appointed by office shall cease to be members upon ceasing to hold the office entitling appointment to the board.

*Powers of the board*

- 1.—(1) Subject to the provisions of this paragraph, and of any provisions of the Minister under this Act, the board shall have power to do anything which in its opinion is calculated to facilitate the carrying out of its activities.
- (2) The board shall not have power to borrow money or to dispose of any property except with the prior consent of the Minister.
- (3) Except in accordance with scales approved by the Minister, the board shall not have power to pay remuneration (including pensions) or allowances or expenses to any member, officer or servant of the board or to any other person.

*Proceedings of the board*

3. Subject to the provisions of this Act the board may make orders and regulations for the purpose of giving effect to the provisions of this Act and for the purpose of carrying into effect the provisions of this Act.
4. Where at least one representative from each of the Regions is present, seven members including the chairman for the meeting shall constitute a quorum.
5. The chairman shall preside at all meetings at which he is present; and in his absence the members attending may elect one of their number to be chairman of the meeting.
6. Questions for determination shall be decided by a majority of the votes of members present and voting thereon. Every member other than a co-opted member shall have a deliberative vote for the purpose; and in the event that the votes are equal the chairman shall have in addition to his deliberative vote, a casting vote.
- 7.—(1) Subject to the provisions of standing orders, the board shall meet whenever it is summoned by the chairman; and if the chairman is required to do so by notice given to him by not less than three other members, he shall summon a meeting of the board to be held within fourteen days from the date when the notice is given.
- (2) Where the board desires to obtain the advice of any person on any particular matter, the board may co-opt that person as a member for a specified period as it thinks fit; but a person who is a member by virtue of this subparagraph shall not count towards a quorum.
- (3) The first meeting of the board shall, notwithstanding the provisions of this paragraph, be summoned by the Minister who may give such directions as he thinks fit as to the procedure which shall be followed at the meeting. Any other meeting may be convened by the Minister if the chairman fails or refuses to do so.

*Committees*

- 8.—(1) The board may appoint one or more committees to carry out on behalf of the board, such of its functions as the board may determine.
- (2) A committee appointed under this paragraph shall consist of a specified number of persons determined by the board, and not more than a third of those persons may be persons who are not members of the board.

the board ; and a person other than a member of the board shall hold office on the committee in accordance with the terms of the instrument by which he is appointed.

(3) A decision of a committee of the board shall be of no effect until it is confirmed by the board.

#### *Miscellaneous*

9.—(1) The fixing of the seal of the board shall be authenticated by the signature of the chairman or of some other member authorised generally or specially by the board to act for that purpose.

(2) Any contract or instrument which, if made or executed by a person not being a body corporate, would not be required to be under seal may be made or executed on behalf of the board by any person generally or specially authorised to act for that purpose by the board.

(3) Any document purporting to be a document duly executed under the seal of the board shall be received in evidence and shall, unless the contrary is proved, be deemed to be so executed.

10. The validity of any proceedings of the board or a committee thereof shall not be affected by any vacancy in the membership of the board or committee, or by any defect in the appointment of a member of the board or of a person to serve on the committee, or by reason that a person not entitled to do so took part in the proceedings.

11. Any member of the board, and any person holding office on a committee of the board, who has a personal interest in any contract or arrangement entered into or proposed to be considered by the board or a committee thereof shall forthwith disclose his interest to the board and shall not vote on any questions relating to the contract or arrangement.

12. A person shall not, by reason only of his membership of the board, be treated as holding an office of emolument under the State.

## SECOND SCHEDULE

Section 10 (5)

### SUPPLEMENTARY PROVISIONS RELATING TO THE DISCIPLINARY COMMITTEE AND INVESTIGATING PANEL

#### *The Tribunal*

1. The quorum of the disciplinary committee shall be four, who shall all be pharmacists.

2.—(1) The Chief Justice of Nigeria shall make rules as to the selection of members of the disciplinary committee for the purposes of any proceedings and as to the procedure to be followed and the rules of evidence to be observed in proceedings before such committee.

(2) The rules shall in particular provide—

(a) for securing that notice of the proceedings shall be given, at such time and in such manner as may be specified by the rules, to the person who is the subject of the proceedings ;

(b) for determining who, in addition to the person aforesaid, shall be a party to the proceedings ;

(c) for securing that any party to the proceedings shall, if he so requires, be entitled to be heard by the disciplinary committee ;

(d) for enabling any party to the proceedings to be represented by a legal practitioner ;

(e) subject to the provisions of subsection (5) of section eleven of this Act, as to the costs of proceedings before the disciplinary committee ;

(f) for requiring, in a case where it is alleged that the person who is the subject of the proceedings is guilty of infamous conduct in any professional respect, that where the disciplinary committee adjudges that the allegation has not been proved it shall record a finding that the person is not guilty of such conduct in respect of the matters to which the allegation relates ;

(g) for publishing in the gazette notice of any direction of the disciplinary committee which has taken effect providing that a person's name shall be struck off a register.

3. For the purposes of any proceedings before the disciplinary committee, any member of the said committee may administer oaths and any party to the proceedings may sue out of the registry of the Federal Supreme Court writs of subpoena ad testificandum and duces tecum ; but no person appearing before the said committee shall be compelled—

(a) to make any statement before the disciplinary committee tending to incriminate himself ; or

(b) to produce any document under such a writ which he could not be compelled to produce at the trial of an action.

4.—(1) For the purpose of advising the disciplinary committee on questions of law arising in proceedings before it, there shall in all such proceedings be an assessor to the said committee who shall be appointed by the board on the nomination of the Chief Justice of Nigeria and shall be a legal practitioner of not less than seven years standing.

(2) The Chief Justice of Nigeria shall make rules as to the functions of assessors appointed under this paragraph, and in particular such rules shall contain provisions for securing—

(a) that where an assessor advises the disciplinary committee on any question of law as to evidence, procedure or any other matters specified by the rules, he shall do so in the presence of every party or person representing a party to the proceedings who appears thereat or, if the advice is tendered while the said committee is deliberating in private, that every such party or person as aforesaid shall be informed what advice the assessor has tendered ;

(b) that every such party or person as aforesaid shall be informed if in any case the disciplinary committee does not accept the advice of the assessor on such a question as aforesaid.

(3) An assessor may be appointed under this paragraph either generally or for any particular proceedings or class of proceedings, and shall hold and vacate office in accordance with the terms of the instrument by which he is appointed.

*The panel*

5. The quorum of the panel shall be three all of whom shall be pharmacists.

6.—(1) The panel may, at any meeting of the panel attended by not less than six members of the panel make standing orders with respect to the panel.

(2) Subject to the provisions of any such standing orders, the panel may regulate its own procedure.

*Miscellaneous*

7.—(1) A person ceasing to be a member of the disciplinary committee or the panel shall be eligible for reappointment as a member of that body.

(2) A person may, if otherwise eligible, be a member of both the disciplinary committee and the panel; but no person who acted as a member of the panel with respect to any case shall act as a member of the said committee with respect to that case.

8. The disciplinary committee or the panel may act notwithstanding any vacancy in its membership; and the proceedings of either body shall not be invalidated by any irregularity in the appointment of a member of that body, or (subject to subparagraph (2) of paragraph 7 above) by reason of the fact that any person who was not entitled to do so took part in the proceedings of that body.

9. The disciplinary committee and the panel may each sit in two or more divisions.

10. Any document authorised or required by virtue of this Act to be served on the disciplinary committee or the panel shall be served on the registrar.

11. Any expenses of the disciplinary committee or the panel shall be defrayed by the board.

12. A person shall not, by reason only of his appointment as a legal assessor to the disciplinary committee or as a member of the panel, be treated as holding an office of emolument under the State.

---

### THIRD SCHEDULE

PART A—ENACTMENT REPEALED *Section 16 (3) (a)*

*Extent of repeal*

Chapter  
152

*Short title*  
Pharmacy Act

Part II and Part III except sections 15,  
19, 20, 22, 23, 25 and 26

PART B—ENACTMENT AMENDED		Sections 16 (3) (b) and 17
Chapter	Short title	Extent of amendment
152	Pharmacy Act	In section two, in the definition of—

- (a) "the Board" there shall be substituted for the words "the Pharmacy Board established under this Act" the words "the Pharmacists Board of Nigeria established under the Pharmacists Act, 1964"
- (b) "chemist and druggist" there shall be substituted for the words defined and the interpretation thereof the following definition—  
' "chemist" means a person permitted to practise as a pharmaceutical chemist under the Pharmacists Act, 1964 and authorised under this Act to import, mix, compound, prepare, dispense and sell drugs and poisons, and includes any person who immediately before the commencement of the Pharmacists Act, 1964 was authorised under this Act to so deal in drugs and poisons as a chemist and druggist, which authority or licence, as the case may be, is still in force on the commencement of the Pharmacists Act, 1964, and references in this Act shall be so construed accordingly ; "
- (c) "dispenser" there shall be substituted for all words after "means" the words "the holder of a certificate as such under any enactment repealed by this Act and duly recognised in the provisional register of the Pharmacists Board of Nigeria" ;
- (d) "Pharmaceutical Registrar" there shall be substituted for the words defined the word "registrar" and in the interpretation thereof for the words "section seven" there shall be substituted the words "the Pharmacists Act, 1964".

In section twenty, for the words in paragraph (b) there shall be substituted the words—  
"a pharmacist licensed under the Pharmacists Act, 1964".

<i>Chapter</i>	<i>Short title</i>	<i>Extent of amendment</i>
		In section twenty-two in subsections (2), (4), (6) and (7) for the words "Pharmaceutical Registrar" there shall be substituted the word "registrar".
		In section twenty-three in subsection (1), for the words "Pharmaceutical Registrar" there shall be substituted the word "registrar".
		In section forty-nine in subsection (1) there shall be repealed the words "and druggist".
		In section sixty-nine in subsection (1) there shall be repealed—
		(a) paragraph (b)
		(b) the words "certificates, diploma," in paragraph (c)
		(c) the words "certificate, diploma," in paragraph (d).

---

FOURTH SCHEDULE      *Sections 17 and 19 (1)*

ENACTMENT AFFECTED

<i>Chapter</i>	<i>Short title</i>	<i>Extent affected</i>
152	Poisons and Pharmacy Act	Sections 1 and 2 of Part I ; Sections 15, 19, 20, 22, 23, 25 and 26 of Part III ; and Part IV to the end of the Act.



**SUPPLEMENTARY APPROPRIATION (1964-65)  
ACT, 1964**



1964, No. 27

AN ACT TO AUTHORISE THE ISSUE OUT OF THE CONSOLIDATED REVENUE FUND OF EIGHT HUNDRED AND FORTY-SEVEN THOUSAND, FIVE HUNDRED POUNDS FOR THE PURPOSE OF REPLACING ADVANCES FROM THE CONTINGENCIES FUND AND OF MAKING FURTHER PROVISION FOR THE SERVICE OF THE YEAR ENDING ON THE THIRTY-FIRST DAY OF MARCH, ONE THOUSAND NINE HUNDRED AND SIXTY-FIVE ; AND TO APPROPRIATE THAT AMOUNT FOR THE PURPOSE SPECIFIED IN THIS ACT.

[12th October, 1964]

BE IT ENACTED by the Legislature of the Federation of Nigeria in this present Parliament assembled and by the authority of the same as follows :—

1. The aggregate amount mentioned in section one of the Appropriation Act, 1964 (which provides for the issue out of the Consolidated Revenue Fund in respect of the year ending on the 31st day of March, 1965, of sums not exceeding in aggregate £62,275,980) shall be increased by eight hundred and forty-seven thousand five hundred pounds ; and the additional amount shall be appropriated—

- (a) as to five thousand five hundred pounds to the replacement of an advance from the Contingencies Fund ; and
- (b) as to eight hundred and forty-two thousand pounds to heads of expenditure as indicated in the Schedule to this Act ;
- and subsection (3) of section one of the Appropriation Act, 1964<sup>5</sup> (which provides for the lapse of balances outstanding at the end of the financial year) shall have effect accordingly.

Commence-  
ment.

Issue and  
appropria-  
tion of  
£847,500  
from the  
Consoli-  
dated  
Revenue  
Fund for  
Contin-  
gencies  
Fund and  
for service  
of 1964-65  
1964,  
No. 23.

Short  
title and  
extent.

2. This Act may be cited as the Supplementary Appropriation (1964-65) Act, 1964, and shall apply throughout the Federation.

Section 1	SCHEDULE	<i>Amount</i>
<i>Head</i>		£
23 Police .. .. .		115,000
36 Ministry of Education		342,000
41 Ministry of Finance		300,000
45 Ministry of Health		15,000
48 Prisons		70,000
Total		<u>£842,000</u>

# SUPREME COURT (AMENDMENT) ACT, 1964



1964, No. 28

AN ACT TO AMEND THE SUPREME COURT ACT, 1960 BY PRESCRIBING THE PRECEDENCE OF THE JUSTICES.

[12th October, 1964]

Commencement.

BE IT ENACTED by the Legislature of the Federation of Nigeria in this present Parliament assembled and by the authority of the same as follows :—

1. The Supreme Court Act, 1960 is amended by inserting immediately after section three a new section threeA as follows :—

Precedence of the Justices.

“3A. The Chief Justice shall take precedence of the other Justices of the Supreme Court, and the other Justices shall take precedence after the Chief Justice in accordance with the instructions of the President, acting on the advice of the Prime Minister.”

2. This Act may be cited as the Supreme Court (Amendment) Act, 1964 and shall be read as one with the Supreme Court Act, 1960 and shall apply throughout the Federation.

Short title, application, etc.  
No. 12 of 1960.



# EXPORT OF NIGERIAN PRODUCE (MID-WESTERN NIGERIA APPLICATION) ACT, 1964



1964, No. 29

AN ACT TO AMEND THE EXPORT OF NIGERIAN PRODUCE ACT, 1958, SO AS TO MAKE SPECIFIC PROVISION FOR MID-WESTERN NIGERIA

[12th October, 1964]

Commencement,

WHEREAS the Export of Nigerian Produce Act, 1958 (hereafter in this Act referred to as "the principal Act") makes divers provisions in respect of regional marketing boards and of the application of the regional marketing laws :

No. 36 of 1958.

AND WHEREAS doubts have arisen as to the extent of application of the principal Act to Mid-Western Nigeria and it is necessary that they be resolved :

BE IT THEREFORE ENACTED by the Legislature of the Federation of Nigeria in this present Parliament assembled and by the authority of the same as follows :

1. In section two of the principal Act (which provides sundry interpretations for use in the principal Act)—

Meaning of sundry expressions extended or explained.

(a) in the definition of "Regional Marketing Board" that definition shall be amended by inserting at the end thereof the words "or the Mid-Western Region Marketing Board" ; and

(b) the Western Region Marketing Law 1954 referred to in the expression "Regional Marketing Law" shall apply to Mid-Western Nigeria as effectively as it applies to Western Nigeria but subject to section two of the Mid-Western Nigeria (Transitional Provisions) Act, 1963 (which provides for the continuance only in certain circumstances of divers laws).

1963 No. 19.

*Export of Nigerian Produce*  
*(Mid-Western Nigeria Application)*

---

Short title,  
citation and  
application.

2.—(1) This Act may be cited as the Export of Nigerian Produce (Mid-Western Nigeria Application) Act, 1964 and this Act and the principal Act as heretofore amended may be cited together as the Export of Nigerian Produce Acts 1958 to 1964.

(2) This Act shall apply throughout the Federation.

# CIVIL AVIATION ACT, 1964



## ARRANGEMENT OF SECTIONS

### *Control of air navigation*

#### *Section*

1. Power to regulate air navigation.
2. Investigation of accidents.
3. Dangerous flying.

### *Control of air transport undertakings, etc.*

4. Licensing of air transport undertakings.
5. Duty to furnish information about air transport undertakings.

### *Provision of airports and control of land for aviation purposes*

6. Power of Minister to provide airports, etc.
7. Control of land in the interests of aviation.
8. Indication of presence of obstructions near airports.

### *Special provisions as to trespass, nuisance, salvage and patents, etc.*

9. Liability in respect of trespass, nuisance and surface damage from aircraft.
10. Liability in respect of nuisance at airports.
11. Application to aircraft of law of wreck and salvage.
12. Exemption of aircraft etc. from seizure on patent claims.

### *General*

13. Offences.
14. Compensation.
15. Application of Act to the state.
16. Subsidiary legislation.
17. Interpretation, etc.
18. Repeals and transitional provisions.
19. Short title, extent and commencement.

SCHEDULE—Enactments repealed.



## 1964, No. 30

AN ACT TO MAKE FRESH PROVISION AS RESPECTS CIVIL AVIATION; AND FOR CONNECTED PURPOSES.

[See section 19(2)]

Commencement.

BE IT ENACTED by the Legislature of the Federation of Nigeria in this present Parliament assembled and by the authority of the same as follows:—

*Control of air navigation*

1.—(1) The Minister may by regulations make such provision as appears to him to be necessary or expedient—

Power to regulate air navigation.

(a) for carrying out the Convention on International Civil Aviation concluded at Chicago on the seventh day of December, 1944, any recommended practices and is adopted in accordance with the convention, and any amendment of the convention or of any such annex which is made in accordance with the convention;

(b) generally for regulating air navigation.

(2) Without prejudice to the generality of the foregoing subsection, the powers conferred by that subsection shall in particular include power to make regulations—

(a) as to the registration of aircraft in Nigeria;

(b) for prohibiting aircraft from flying unless certificates of airworthiness issued or validated under the regulations are in force with respect to them and except upon compliance with such conditions as to maintenance and repair as may be prescribed;

(c) for the licensing, inspection and regulation of airports, for access to airports and places where aircraft have landed, for the inspection of aircraft factories, and for prohibiting or regulating the use of airports which are not licensed in pursuance of the regulations;

(d) for prohibiting persons from engaging in, or being employed in or in connection with, air navigation in such capacities as may be prescribed unless they satisfy the prescribed requirements, and for the licensing of persons employed at airports in the inspection, testing or supervision of aircraft;

(e) as to the conditions under which, and in particular the airports to or from which, aircraft entering or leaving Nigeria may fly, and as to the conditions under which aircraft may fly from one part of Nigeria to another;

(f) as to the conditions under which passengers and goods may be carried by air and under which aircraft may be used for other lawful purposes, and for prohibiting the carriage by air of goods of such classes as may be prescribed;

(g) for minimizing or preventing interference with the use or effectiveness of apparatus used in connection with air navigation, and for prohibiting or regulating the use of such apparatus and the display of signs and lights liable to endanger aircraft ;

(h) generally for securing the safety, efficiency and regularity of air navigation and the safety of aircraft and of persons and property carried in aircraft, and for preventing aircraft from endangering other persons and property ;

(i) for requiring persons engaged in, or employed in or in connection with, air navigation to supply meteorological information for the purposes of air navigation ;

(j) for regulating the making of signals and other communications by or to aircraft and persons carried in aircraft ;

(k) for instituting and regulating the use of a civil air ensign and any other ensign established by the Minister for purposes connected with air navigation ;

(l) for prohibiting aircraft from flying over such areas in Nigeria as may be prescribed ;

(m) for applying, with or without modifications, the enactments relating to customs in relation to airports and to aircraft and to persons and property carried in aircraft ;

(n) as to the manner and conditions of the issue, validation, renewal, extension or variation of any certificate, licence or other document required by the regulations (including the examinations and tests to be undergone), and as to the form, custody, production, cancellation, suspension, endorsement and surrender of any such document ;

(o) for the registration of births and deaths occurring in aircraft and of particulars of persons missing from aircraft ;

(p) for regulating the charges that may be made for the use of airports licensed under the regulations and for services provided at such airports ;

(q) for specifying the fees to be paid in respect of the issue, validation, renewal, extension or variation of any certificate, licence or other document or the undergoing of any examination or test required by virtue of the regulations and in respect of any other matters in respect of which it appears to the Minister to be expedient for the purposes of the regulations to charge fees ;

(r) for exempting from the provisions of the regulations or any of them any aircraft or persons or classes of aircraft or persons.

(3) Regulations under this section may provide for the imposition of penalties for offences against the regulations, not exceeding in the case of any particular offence a fine of five hundred pounds and imprisonment for a term of six months, and, subject to Chapter III of the Constitution of the Federation (which relates to fundamental rights), for the taking of such steps (including firing on aircraft) as may be prescribed as respects aircraft flying over areas of Nigeria over which flying is prohibited by the regulations.

2.—(1) Without prejudice to the generality of subsection (1) of the foregoing section, the Minister may make regulations providing for the investigation of any accident arising out of or in the course of air navigation of aircraft elsewhere.

Investigation of accidents.

(2) Without prejudice to the generality of the foregoing subsection, regulations under this section may in particular contain provision—

(a) requiring notice to be given of any such accident as aforesaid in such manner and by such persons as may be prescribed—

(b) applying, with or without modifications, for the purpose of investigations held with respect to any such accidents any of the provisions of any law in force in Nigeria relating to the investigation of deaths or accidents ;

(c) prohibiting, pending investigation, access to or interference with aircraft to which an accident has occurred and authorising any person, so far as may be necessary for the purposes of an investigation, to have access to, examine, remove, take measures for the preservation of, or otherwise deal with, any such aircraft ;

(d) authorising or requiring the cancellation, suspension, endorsement or surrender of any licence or certificate granted in Nigeria in pursuance of this Act or the withdrawal or suspension of any validation conferred in Nigeria of a licence granted by a competent authority elsewhere, where it appears on investigation that the licence, certificate or validation ought to be so dealt with, and requiring the production accordingly of any such licence or certificate.

3.—(1) Where an aircraft is flown in such a manner as to cause danger to any person or property on land or water, the pilot or other person in charge of the aircraft and the owner of the aircraft shall be liable on summary conviction to a fine not exceeding two hundred pounds or imprisonment for a term not exceeding six months or both.

Dangerous flying.

(2) In any proceedings against the owner of an aircraft in respect of an alleged offence under this section, it shall be a defence to prove that the act alleged to constitute the offence was done without the knowledge and consent of the owner.

(3) In this section "owner", in relation to an aircraft and an alleged offence, includes any person by whom the aircraft is hired at the time of the alleged offence.

(4) Nothing in subsection (1) of this section shall be construed as derogating from the powers conferred by section one of this Act.

#### *Control of air transport undertakings, etc.*

4.—(1) The Minister may make regulations—

(a) to secure that aircraft shall not be used in Nigeria by any person—

(i) for plying, while carrying passengers or goods for reward, on such journeys or classes of journeys (whether beginning and ending at the same point or at different points) as may be prescribed ;

Licensing of air transport undertakings.

(ii) for such flying undertaken for the purpose of any trade or business as may be prescribed, except under the authority of and in accordance with a licence granted to him by the prescribed authority ;

(b) as to the circumstances in which a licence may or shall be granted, refused, revoked or suspended, and in particular as to the matters to which the licensing authority is to have regard in deciding whether to grant or refuse a licence ;

(c) as to appeals (if any) from the licensing authority by persons interested in the grant, refusal, revocation or suspension of a licence ;

(d) as to the conditions which may be attached to a licence (including conditions as to the fares, freight or other charges to be charged by the holder of the licence), and for securing compliance with any conditions so attached ;

(e) as to the information to be furnished by an applicant for, or the holder of, a licence to such authorities as may be prescribed ; and

(f) specifying the fees to be paid in respect of the grant of a licence, or enabling such fees to be specified by such person or authority as may be prescribed.

(2) Regulations made under this section may provide for the imposition of penalties for offences against the regulations, not exceeding—

(a) in the case of a first offence against any particular provision, a fine not exceeding five hundred pounds or imprisonment for a term not exceeding three months or both ; and

(b) in the case of a second or subsequent offence against the same provision, a fine not exceeding five thousand pounds or imprisonment for a term not exceeding two years or both.

5.—(1) The Minister may make regulations—

(a) requiring any person who carries on the business of carrying passengers or goods in aircraft for reward, on such journeys or classes of journeys (whether beginning and ending at the same point or at different points) as may be prescribed, to furnish to the prescribed authorities such information relating to the use of aircraft for the purpose of the business, and to the persons employed in connection with that use, as may be prescribed ; and

(b) specifying the times at which, and the form and manner in which, any information required under the regulations is to be furnished.

(2) Regulations under this section may provide for the imposition of penalties for offences against the regulations, not exceeding in the case of any particular offence a fine of twenty pounds and a further fine of five pounds for every day on which the offence continues after conviction of it.

(3) No information with respect to any particular undertaking which has been obtained by virtue of regulations under this section shall, without the consent of the person carrying on that undertaking, be disclosed otherwise than in connection with the execution of the regu-

lations ; and if any person discloses any such information in contravention of this subsection he shall be liable, on summary conviction to imprisonment for a term not exceeding three months or a fine not exceeding fifty pounds or both or, on conviction on indictment, to imprisonment for a term not exceeding two years or a fine not exceeding one hundred pounds or both.

(4) Nothing in the last foregoing subsection shall apply to the disclosure of any information for the purposes of any legal proceedings which may be taken by virtue of that subsection or of regulations made under this section, or for the purposes of any report of such proceedings ; but save as aforesaid that subsection shall, in relation to any legal proceedings (including arbitration), preclude any person who is in possession of any information obtained by virtue of such regulations from disclosing, and from being required by any court or arbitrator to disclose, that information without the consent of the person carrying on the undertaking to which the information relates.

*Provision of airports and control of land for aviation purposes*

6.—(1) The Minister may establish and maintain airports and may provide and maintain, in connection with airports established by him, roads, approaches, apparatus, equipment and buildings and other accommodation.

Power of Minister to provide airports, etc.

(2) For the avoidance of doubt it is hereby declared that the following purposes are public purposes of the Federation within the meaning of the Public Lands Acquisition Act, that is to say—

Cap. 167.

(a) the purposes of subsection (1) of this section ; and

(b) the purpose of securing that land in the vicinity of the site of an airport which the Minister has established or acquired or is about to establish or acquire shall not be used in such a manner as to cause interference with, or danger or damage to, aircraft at, approaching or leaving the airport.

7.—(1) The Minister may, if he is satisfied that it is necessary so to do in order to secure the safe and efficient use for civil aviation purposes of any land, structure, works or apparatus vested in him or which he proposes to acquire or instal, by order declare that any area of land specified in the order shall be subject to control by directions given in accordance with the following provisions of this section.

Control of land in the interests of aviation.

(2) Where any such order is in force, the Minister may, in accordance with provisions of the order in that behalf, give directions—

(a) for requiring the total or partial demolition of any building or structure within the area to which the order relates ;

(b) for restricting the height of trees and other vegetation upon any land within the area, or for requiring any tree or other vegetation upon any such land to be cut down or reduced in height ;

(c) for extinguishing any private right of way over land within the area ;

(d) for restricting the installation of cables, mains, pipes, wires or other apparatus over, on or under any land within the area ;

(e) for extinguishing, at the expiration of such period as may be specified by the directions, any subsisting right of installing or maintaining any such apparatus as aforesaid over, on or under any land within the area ; and

(f) for requiring that, before the expiration of such period as may be specified by the directions, any such apparatus shall be removed from land within the area.

(3) An order under this section may contain provision for empowering any person authorised in that behalf by the Minister to move or alter, so as to bring it into conformity with the requirements of any directions given under the order, any building, structure, vegetation or apparatus which contravenes those requirements.

(4) Where the Minister makes or has under consideration the making of an order under this section in respect of any land, any person authorised in that behalf in writing by the Minister may at all reasonable times, on producing if so required evidence of his authority, enter upon any of the land in order to make any survey which the Minister requires to be made for the purposes of any steps to be taken in consequence of the order or, as the case may be, for the purpose of determining whether the order should be made :

Provided that admission shall not, by virtue of this subsection, be demanded as of right to any land which is occupied unless twenty-four hours notice in writing of the intended entry has been served on the occupier.

(5) The Minister shall give notice of any direction given in pursuance of this section by publishing the direction in the Gazette of the Federation and by taking such steps as he considers reasonable for securing that a copy of the direction is served on each person appearing to him to be the owner or occupier of any land to which the direction relates.

(6) A person who obstructs any other person in the exercise of any powers conferred upon that other person by virtue of subsection (3) or subsection (4) of this section shall be guilty of an offence and liable on summary conviction to imprisonment for a term not exceeding six months or a fine of an amount not exceeding one hundred pounds or both.

(7) A person who incurs expense or suffers damage by reason of the giving of a direction in pursuance of this section shall be entitled to receive from the Minister adequate compensation in respect of the expense or damage.

(8) The powers of the Minister under this section shall not be construed as prejudicing his power to acquire land for the purpose of securing the observation of any requirement which might have been imposed under this section in relation to the land.

8.—(1) If the Minister is satisfied, with respect to any building or structure in the vicinity of an airport to which this section applies, or that in order to avoid danger to aircraft flying in that vicinity in darkness, or conditions of poor visibility, provision ought to be made (whether by lighting or otherwise) for giving to such aircraft warning of the presence of that building or structure, he may by order authorise (subject to any conditions specified in the order) the proprietor of the airport and any person acting under the proprietor's instructions—

Indication of presence of obstructions near airports.

(a) to execute, instal, maintain, operate, and as occasion requires to repair and alter, such works and apparatus as may be necessary for enabling such warning to be given in the manner specified in the order; and

(b) so far as may be necessary for exercising any of the powers conferred by the order, to enter upon and pass over (with or without vehicles) any such land as may be specified in the order:

Provided that no such order shall be made in relation to any building or structure if it appears to the Minister that there have been made, and warning as aforesaid.

(2) The Minister shall, before making any such order as aforesaid—

(a) cause to be published, in such manner as he thinks best for informing persons concerned, notice of the proposal to make the order and of the place where copies of the draft order may be obtained free of charge; and

(b) take into consideration any representations with respect to the order which may, within such period not being less than two months after the first publication of the notice as may be specified therein, be made to him by any person appearing to him to have an interest in any land which would be affected by the order;

and at the end of that period the order may, subject to the provisions of this section, be made with such modifications (if any) of the original draft as the Minister thinks proper.

(3) Every such order as aforesaid shall provide—

(a) that, except in a case of emergency, no works shall be executed on any land in pursuance of the order unless, at least fourteen days previously, the proprietor of the airport to which the order relates has served in the manner specified by the order on the occupier of that land, and on every other person known by the proprietor to have an interest in the land, a written notice containing such particulars of the nature of the proposed works, and the manner in which and the time at which it is proposed to execute them, as may be specified by the order; and

(b) that if within fourteen days from the service of the said notice on any person having such an interest the proprietor of the airport receives written objection on the part of that person to the proposals contained in the notice then, except in so far as the objection is withdrawn, no steps shall be taken in pursuance of the notice without the specific authority of the Minister;

and shall also provide for requiring the proprietor of the airport to which the order relates to pay to any person having an interest in any land affected by the order adequate compensation for any loss or damage which that person may suffer in consequence of the order; and for the purposes of this subsection any expense reasonably incurred in connection with the lawful removal of any apparatus installed in pursuance of such an order, and so much of any expense incurred in connection with the repair, alteration, demolition or removal of any building, structure or erection to which such an order relates as is attributable to the operation of the order, shall be deemed to be loss or damage suffered in consequence of the order.

(4) The ownership of any thing shall not be taken to be affected by reason only that it is placed in, or affixed to, any land in pursuance of such an order as aforesaid; and (subject to the provisions of the next following subsection) so long as any such order in respect of an airport is in force, no person shall, except with the consent of the proprietor of the airport, wilfully interfere with any works or things which, to the knowledge of that person, are works or things executed or placed in, on or over any land in pursuance of the order.

If any person contravenes the foregoing provisions of this subsection, he shall be liable on summary conviction to imprisonment for a term not exceeding six months or a fine not exceeding two hundred pounds or both; and every person who wilfully obstructs a person in the exercise of any of the powers conferred by such an order as aforesaid shall be liable on summary conviction to a fine not exceeding fifty pounds.

(5) Nothing in this section shall operate, in relation to any building or structure, so as to restrict the doing of any work for the purpose of repairing, altering, demolishing or removing the building or structure if—

(a) notice of the doing of the work is given as soon as may be to the proprietor of the airport; and

(b) the giving of warning of the presence of the building or structure in the manner provided by any order under this section in force in relation thereto is not interrupted.

(6) In this section—

(a) the expression "airport to which this section applies" means—

(i) an airport under the control of the Minister or of the Minister of the government of the Federation responsible for defence; or

(ii) any premises which, in pursuance of regulations made under section one of this Act, are for the time being licensed as an airport for public use; and

(b) the expression "proprietor of the airport" means—

(i) in the case of such an airport as is mentioned in sub-paragraph (i) above, the officer in charge of the airport; and

(ii) in any other case, the holder of the licence issued in respect of the airport in pursuance of this Act.

*Special provisions as to trespass, nuisance, liability and patents, etc.*

9.—(1) No action shall lie in respect of trespass or nuisance by reason only of, or of the ordinary incidents of, the flight of an aircraft over any property at a height above the ground which is reasonable having regard to wind, weather and all the circumstances of the case.

Liability in respect of trespass, nuisance and surface damage from aircraft.

(2) Where loss or damage is caused to any person or property on land or water by, or by a person in or in an article or person falling from, an aircraft while in flight, taking off or landing, then, without prejudice to the law relating to contributory negligence, damages in respect of the loss or damage shall be recoverable without proof of negligence or intention or other cause of action, as if the loss or damage had been caused by the wilful act, neglect or default of the owner of the aircraft.

Provided that where loss or damage is caused as aforesaid in circumstances in which—

(a) damages are recoverable from the owner in respect of the loss or damage by virtue only of the foregoing provisions of this subsection; and

(b) a legal liability is created in some person other than the owner to pay damages in respect of the loss or damage;

the owner shall be entitled to be indemnified by that other person against any claim in respect of the loss or damage.

(3) References in the last foregoing subsection to loss or damage include, in relation to any person, loss of life and personal injury; and where an aircraft has been bona fide demised or hired out for any period exceeding fourteen days to any other person by the owner of the aircraft and no pilot, commander, navigator or operative member of the crew of the aircraft is in the employment of the owner, the last foregoing subsection shall have effect as if for references to the owner there were substituted references to the person to whom the aircraft has been so demised or hired out.

10.—(1) The Minister may make regulations as to the conditions under which noise and vibration may be caused by aircraft at airports and may provide that subsection (2) of this section shall apply at any airport as respects which provision as to noise and vibration caused by aircraft is so made.

Liability in respect of nuisance at airports.

(2) No action shall lie in respect of nuisance by reason only of the noise and vibration caused by aircraft on an airport in which this subsection applies by virtue of the foregoing subsection so long as the provisions of the regulations in force under that subsection as respects the airport are complied with.

11.—(1) Any services rendered in assisting or in saving the crew, or in saving the cargo or apparel of, an aircraft on, or on or over the surface of, any tidal water, or on or over the shores of the sea or any tidal water, shall be deemed to be salvage services in all cases in which they would have been salvage services if they had been rendered in relation to a

Application of law of salvage to aircraft wreck and salvage.

; and where salvage services are rendered by an aircraft to any property or person, the owner of the aircraft shall be entitled to the same and for those services as he would have been entitled to if the aircraft were a vessel.

The foregoing provisions of this subsection shall have effect notwithstanding that the aircraft concerned is a foreign aircraft, and notwithstanding that the services in question are rendered elsewhere than within the limits of the territorial waters of Nigeria.

(2) The Minister may by regulations direct that any provisions of law for the time being in force in Nigeria which relate to wreck, salvage of life or property or to the duty of rendering assistance to vessels in distress shall, with such modifications (if any) as may be prescribed, apply in relation to aircraft as those provisions apply in relation to vessels.

(3) For the purposes of this section, any provisions of any law in force in Nigeria which relate to vessels laid by or neglected as unfit for service shall be deemed to be provisions relating to wreck.

12.—(1) Any lawful entry into Nigeria or any lawful transit across Nigeria, with or without landings, of an aircraft to which this subsection applies shall not entail any seizure or detention of the aircraft or any proceedings against the owner or operator of the aircraft or any other interference with the aircraft by or on behalf of any person in Nigeria on the ground that the construction, mechanism, parts, accessories or operation of the aircraft is or are an infringement of any patent, design or model.

(2) The importation into and storage in Nigeria of spare parts and spare equipment for an aircraft to which this subsection applies and the use and installation thereof in the repair of such an aircraft shall not entail any seizure or detention of the aircraft or of the spare parts or spare equipment or any proceedings against the owner or operator of the aircraft or the owner of the spare parts or spare equipment or any other interference with the aircraft by or on behalf of any person in Nigeria on the ground that the spare parts or spare equipment or their installation are or is an infringement of any patent, design or model.

(3) Subsections (1) and (2) of this section apply—

(a) to any aircraft (other than an aircraft used in military, customs or police services) registered in a country or territory as respects which there is for the time being in force a declaration made by the Minister, with a view to the fulfilment of the relevant provisions of the convention mentioned in section one of this Act, that the benefit of those subsections extends to that country or territory; and

(b) to such other aircraft as the Minister may by order specify:

Provided that subsection (2) of this section shall not apply in relation to any spare parts or spare equipment which are sold or distributed in Nigeria or are exported from Nigeria for sale or distribution.

(4) Where it is alleged by any person interested that a foreign aircraft which is not an aircraft to which subsection (1) of this section applies and which is making a passage through or over Nigeria infringes itself or part of it any invention, design or model which is entitled to

protection in Nigeria, it shall be lawful, subject to and in accordance with rules made by the Minister, to detain the aircraft until the owner of it deposits or secures in respect of the aircraft until the owner (hereafter in this section referred to as "the deposited sum"); and thereupon the aircraft shall not, during the continuance of the passage, be subject to any lien, arrest, detention or prohibition, whether by order of a court or otherwise, on account of the alleged infringement.

(5) The deposited sum shall be such sum as may be agreed between the parties interested or, in default of agreement, as may be fixed by the Minister; and the payment of the deposited sum shall be made or secured to the Minister in such manner as may be specified by rules made by the Minister.

(6) The deposited sum shall be dealt with by such tribunal and in accordance with such procedure as may be prescribed by rules made by the Minister, and the rules may provide generally for carrying the provisions of subsections (4) and (5) of this section into effect.

(7) For the purposes of subsection (4) of this section, the expression "owner" shall include the actual owner of an aircraft and any person claiming through or under him, and the expression "passage" shall include all reasonable landings and stoppages in the course of the passage.

#### General

13.—(1) Any act done by any person on a Nigerian aircraft outside Nigeria which, if it had been done by him in any part of Nigeria, would have constituted an offence under the law in force in that part shall, for the purposes of any criminal proceedings in that part of Nigeria against that person in respect of that act, be deemed to have been done by him in that part of Nigeria. Offences.

(2) Except with the consent of the Attorney-General of the Federation, no proceedings shall be instituted by virtue of the foregoing subsection against a person who was not a citizen of Nigeria at the time of the act in question.

(3) Where it is alleged that an offence under this Act or regulations made by virtue of this Act has been committed, proceedings in respect of the offence may be brought in any court in Nigeria which would have had jurisdiction in the matter if the offence had been committed in the part of Nigeria for which the court acts.

14. A person claiming compensation in pursuance of any provision in that behalf of this Act or of an instrument made by virtue of this Act may, for the purpose of determining his interest in the subject-matter of the claim and the amount of the compensation, apply— Compensation.

(a) where the subject matter of the claim or the usual residence of the claimant is situated in any territory within the meaning of the Constitution of the Federation, to the High Court of that territory;

(b) in any other case, to the High Court of Lagos.

15.—(1) The Minister may by regulations provide that this Act shall bind the state to such extent as may be prescribed. Application of Act to state.

(2) Nothing in the foregoing subsection shall be construed as prejudicing the operation of provisions of this Act referring expressly to a Minister or to a person subject to the control of a Minister.

(1) Any regulations, rules or order made by the Minister in pursuance of this Act may contain—  
such incidental, supplemental, consequential and transitional provisions; and

such provisions as to the extra-territorial operation of the instrument in question, as the Minister considers expedient for the purposes of the regulations, rules or order.

(2) Without prejudice to the generality of the foregoing subsection, regulations under this Act may, for the purpose of securing compliance with the regulations, include provision for the detention of any aircraft in which the regulations relate.

17.—(1) In this Act, unless the context otherwise requires, the following expressions have the meanings hereby assigned to them respectively, that is to say—

“airport” means any area of land or water designed, equipped, set apart or commonly used for affording facilities for the landing and departure of aircraft;

“foreign aircraft” means an aircraft other than a Nigerian aircraft;

“the Minister” means the Minister of the government of the Federation responsible for civil aviation;

“Nigerian aircraft” means an aircraft registered in Nigeria in pursuance of regulations made under section one of this Act; and

“prescribed” means prescribed by regulations made under this Act.

(2) Any power conferred by this Act is in addition to and not in derogation of any other power so conferred.

18.—(1) Subject to the following subsection, the enactments specified in the first and second columns of the Schedule to this Act are hereby repealed to the extent shown in the third column of that Schedule.

(2) Anything done under any enactment repealed by the foregoing subsection shall be deemed to have been done under the corresponding provision of this Act; so however that—

(a) without prejudice to the provisions of section sixteen of this Act, nothing in the foregoing provisions of this subsection shall be construed as continuing in force any order, regulations or other instrument of a legislative character having effect by virtue of an enactment so repealed; and

(b) without prejudice to the operation of section six of the Interpretation Act, 1964 (which relates to the effect of repeals), nothing in the foregoing provisions of this subsection or in the foregoing subsection shall affect any proceedings pending on the day when the foregoing subsection comes into force, and accordingly any such proceedings shall be continued as if that subsection had not been passed.

19.—(1) This Act may be cited as the Civil Aviation Act, 1964, and, without prejudice to the operation of any provision of this Act relating to extra-territorial effect, apply throughout the Federation.

(2) This Act shall come into force on such day as the Minister may appoint, and different days may be so appointed as respects different provisions of this Act.

## SCHEDULE

Section 18.

## Enactments repealed

<i>Chapter or number</i>	<i>Short title</i>	<i>Extent of repeal</i>
Cap. 8.	The Air Navigation (Safety of Navigation) Act.	The whole Act.
Cap. 33.	The Civil Aviation (Births, Deaths and Missing Persons) Act.	The whole Act.
1962, No. 30.	The Merchant Shipping Act, 1962.	In section four hundred and twenty-seven, paragraph (p).
1963, No. 17.	The Director of Civil Aviation (Transfer of Functions) Act, 1963.	The whole Act.
S.I. 1952 No. 868, 1953 Nos. 591 and 1669, 1954 No. 830, 1955 No. 709, 1958 No. 1514, and 1959 No. 1052.	The Colonial Civil Aviation (Application of Act) Orders, 1952 to 1959.	The whole of the Orders.



# NIGERIAN CIVIL AVIATION TRAINING CENTRE ACT, 1964



## ARRANGEMENT OF SECTIONS

### *Section*

1. Establishment of the Nigerian civil aviation training centre
2. Power to appoint a principal for the training centre.
3. Board of governors.
4. Financial provisions.
5. Report on training centre in each year.
6. Travelling allowances etc. to members of the board.
7. Advisory council.
8. Pensions in special cases.

9. Regulations.
10. Validation of past acts etc.
11. Disposal of property of the special fund.
12. Interpretation.
13. Short title, commencement and application.

### SCHEDULES

- First Schedule—Supplementary provisions relating to the board.
- Second Schedule—Transitional provisions as to property, etc.



## 1964, No. 31

AN ACT TO MAKE PROVISION FOR A TRAINING ORGANISATION TO BE KNOWN AS THE NIGERIAN CIVIL AVIATION TRAINING CENTRE, TO PROVIDE FOR ITS ORGANISATION, CONTROL AND OPERATION, AND FOR CONNECTED PURPOSES.

BE IT ENACTED by the Legislature of the Federation of Nigeria in this present Parliament assembled and by the authority of the same as follows:—

[section 13 (1)]

Commence-  
ment.

1.—(1) There shall be established at Zaria a training organisation to be known as the Nigerian Civil Aviation Training Centre (hereafter in this Act referred to as "the training centre") which shall be a body corporate under that name and, subject to the provisions of this Act, the training centre shall be charged with the general duty of providing—

Establish-  
ment of the  
Nigerian civil  
aviation  
training  
centre.

(a) civil aviation courses, standard or special, designed for use in flight training or in airport operation and management as may from time to time be prescribed under this Act for approved persons:

(b) training of approved persons in the installation, maintenance and operation, as the case may be, of technical equipment the use of which is calculated or likely to increase the margin of operational safety of civil aircraft services:

(c) equipment and necessary facilities for technical research or normal use by approved persons at the training centre as may from time to time be authorised or allowed by the board of governors under this Act.

(2) Courses provided for the purposes of subsection (1) of this section shall include the organisation of incidental study groups and the delivery of necessary series of lectures; and if approved, fees may be calculated and be charged at such rate, not exceeding the estimated cost of course, as may be prescribed under this Act.

(3) The training centre as a body corporate shall have perpetual succession and a common seal which shall be kept in the custody of the principal of the training centre; and the training centre may hold or acquire property, movable and immovable, but shall not mortgage, charge or dispose of any property held by it over the value of fifty pounds without the consent in writing of the Minister.

2. The Minister shall appoint a fit person as head of the training centre and its principal; and the principal shall be responsible to the board of governors under this Act for the day to day administration and control of the training centre, and shall perform such other duties as may from time to time be prescribed under this Act.

Power to  
appoint  
principa  
for the  
training  
centre.

## Nigerian Civil Aviation Training Centre

There shall be a board of governors (hereafter in this Act as "the board") as members of the training centre charged with responsibility for the organisation, administration and policy of the training centre, and the board shall consist of the following—

- 1) one fit person appointed as chairman by the Council of Ministers;
- 2) three other fit persons having experience in or some knowledge of aviation problems, to be appointed as members by the Minister;
- 3) one fit person to be appointed by the International Civil Aviation Organisation (hereafter in this Act referred to as "the executing agency"); and

The director for the time being of the United Nations' Special programmes in Nigeria (which fund is hereafter in this Act referred to as "the special fund").

The principal of the training centre shall be secretary to the board and shall attend the meetings of the board; and in his absence the secretary shall act as secretary at meetings attended by him, but the secretary nor his deputy acting for him in that capacity shall have a vote at meetings of the board.

3) The Minister may give to the board directions of a general nature or relating generally to particular matters and, in any event, it continues to operate in Nigeria, not inconsistent with the directions of the special fund, or of the executing agency; and the board shall comply with any such directions given by the Minister.

4) Subject to the provisions of subsection (3) of this section the board may—

a) prescribe the general policy of the training centre in consultation with the principal of the training centre and the fees to be charged in respect thereof;

b) regulate the organisation and management of the training centre;

c) prescribe the duties of the principal of the training centre and the members of its staff;

d) provide for the appointment, promotion, dismissal and transfer of members of the staff at the training centre and for their salaries;

e) make provision for a pension scheme for members of the staff of the training centre;

f) approve annual accounts and estimates;

g) as and when required make any necessary contact between the training centre and any persons not connected therewith;

h) submit annual reports to the Minister.

i) The provisions of the First Schedule to this Act shall have effect with respect to the tenure of office of members of the board and other matters there mentioned.

j) In this section "staff" includes all personnel of the training centre other than those employed by the executing agency or by the special fund, or by any other approved foreign agency or organisation.

4.—(1) The funds of the training centre shall comprise—

(a) money allocated to it in each year by the Government of the Federation and, while it continues to operate in Nigeria by the special fund in such shares as may be agreed from time to time :

Financial provisions.

(b) donations and subsidies ;

(c) fees for training received from the training centre ;

(d) moneys from such other sources as may from time to time be approved by the board on behalf of the training centre.

(2) The board shall cause accounts to be kept at all times of the income and expenditure of the training centre and proper records in relation to those accounts. The accounts of the training centre shall be audited as soon as may be after the end of the financial year to which the accounts relate by a person qualified to investigate the affairs of a company under the Companies Act and approved by the Minister.

(3) The board shall prepare and submit to the Minister not later than the last day of December in each and every year after the commencement of this Act an estimate of the expenditure and income during the next financial year.

Cap. 37.

5.—(1) The board shall in every year furnish half-yearly reports to the Minister and while the special fund continues to operate in Nigeria, to both the representatives of the executing agency and of the special fund, on the activities of the training centre. The first of such reports shall be furnished not later than the fifteenth day of July, nineteen hundred and sixty-five, and subsequent reports as nearly as may be on or after the fifteenth days of January and July in each year thereafter ; and every report shall be accompanied by a copy of the audited accounts of the training centre, and of the report (if any) by the auditor on the accounts as audited by him.

Report on training centre in each year.

(2) Copies of the report when made shall be printed and laid before both Houses of Parliament.

6. Members of the board shall be paid such travelling and other allowances at such rate as the Minister may from time to time approve, after consultation with the Minister of the government of the Federation charged with responsibility for finance.

Travelling allowances etc. to members of the board.

7.—(1) There shall be an advisory council consisting of not less than ten members or more than twenty members appointed from time to time by the Minister from among representatives of governments, airlines and civil aviation bodies making use of the training centre.

Advisory council.

(2) Meetings of the advisory council shall be convened by the principal as and when necessary, so however that the advisory council shall meet at least once in each calendar year.

(3) It shall be the duty of the advisory council to make suggestions to the board relative to courses of instruction provided or to be provided by the training centre, and to make recommendations to the Minister for the holding of conferences and meetings at the training centre which members of the advisory council consider suitable or necessary.

The board shall consider all suggestions offered to it by the advisory council under the foregoing subsection and shall give effect to them as far as is practicable.

Members attending a meeting of the advisory council shall be subject to the chairman for the meeting and may regulate its own procedure.

6) The principal or in his absence some person nominated by him shall attend meetings of the advisory council and provide any necessary assistance of a secretarial nature. Any person attending under this subsection may take part in deliberations of the advisory council, but shall not vote on any subject.

8.—(1) The Minister may by order published in the gazette declare that service with the training centre is an approved service for purposes of the Pensions Act and upon such publication the provisions of the Pensions Act 1964 (which extends the application of the Pensions Act in certain cases) shall thereupon have effect.

(2) In this section "Minister" means the Minister of the Government of the Federation charged with responsibility for pensions.

9.—(1) Where any act, matter or thing falls to be prescribed under this Act, any such act, matter or thing may be prescribed by regulations made on behalf of the training centre by the board.

(2) Regulations made under this section shall, when approved by the Minister, be published in the gazette.

10. It is declared for the avoidance of doubt that where any persons have before the commencement of this Act been appointed or have purported to act under powers, however conferred, incidental to the acquisition of land for, or incidental to the erection, supervision or control of, the training centre hereby established, such persons shall be deemed always to have been lawfully appointed, or to have validly exercised the powers, as the case may be.

11.—(1) The Council of Ministers after consultation with the executing agency and of the special fund may prescribe a date not earlier than five years after the commencement of this Act for the preparation of a schedule (hereafter in this section referred to as "the transfer schedule") of the assets in Nigeria of the special fund, and the Accountant-General of the Federation shall, when so directed, and acting in collaboration with the executing agency, the special fund and the board, prepare the transfer schedule accordingly. The transfer schedule shall be certified to by the persons so collaborating, and a copy shall be supplied by the principal of the training centre to the Minister.

(2) On a day to be appointed thereafter by the Minister (hereafter in this Act referred to as "the appointed transfer day") the training centre shall have and may exercise administrative control on behalf of the government of the Federation over all property shown as assets in the transfer schedule, and such assets shall vest in the training centre accordingly.

(3) The provisions of the Second Schedule to this Act shall have effect with respect to any matter arising from the transfer by this section of the training centre of the assets in Nigeria of the special fund and with respect to the other matters mentioned in that Schedule.

12. In this Act unless the context otherwise requires—
- “approved” means approved by the Minister ;
  - “the appointed transfer day” means the day appointed for the purpose of section eleven of this Act for the vesting of certain property of the special fund in the training centre ;
  - “the board” means the board of governors under section three of this Act ;
  - “the executing agency” means the International Civil Aviation Organisation acting on behalf of the special fund ;
  - “the Minister” means the Minister of the government of the Federation charged with responsibility for civil aviation ;
  - “prescribed” means prescribed on behalf of the training centre with the approval of the Minister ;
  - “the principal” means the principal of the training centre ;
  - “the special fund” means the United Nations’ Special Fund administered in Nigeria by the director of the special fund programmes in Nigeria ;
  - “the training centre” means the Nigerian Civil Aviation Training Centre established under section one of this Act.

Interpreta-  
tion.

13.—(1) This Act may be cited as the Nigerian Civil Aviation Training Centre Act, 1964, and shall come into operation on a day to be appointed by the Minister by order in the gazette.

Short title,  
commence-  
ment and  
application.

(2) The Act shall apply throughout the Federation.

## SCHEDULES

### FIRST SCHEDULE

Section 3 (5)

#### SUPPLEMENTARY PROVISIONS RELATING TO THE BOARD

##### *Qualifications and tenure of office of Members*

1.—(1) Subject to the provisions of this paragraph a member of the board shall hold office for such period not exceeding three years as may be set out in the instrument of appointment or if he is a member by office or in a representative capacity he shall be a member while he continues to hold the particular office or be the representative, as the case may be.

(2) Any member of the board who ceases to be a member thereof shall, if he is also a member of a committee thereof cease to hold office on the committee.

(3) Any member appointed by the government of the Federation may by notice in writing under his hand addressed to the Minister and with his consent resign his office, and any member appointed by office or in a representative capacity may, with the consent of the person or body appointing him, resign his office by notice in writing addressed to the minister.

- a) A person who has ceased to be an elected member of the board shall be eligible again to become a member of the board and any elected member may be reappointed.
- b) If for any reason there is a vacation of office by a member and—
- 1) such member was appointed on behalf of the Government of the Federation, another fit person shall be appointed either permanently or temporarily in his stead to be a member of the board ; and
- 2) in any other case the vacancy shall be filled by appointment as the circumstances may require.

#### *Powers of board*

2. Unless otherwise precluded by this Act, the board shall have power to do anything which in the opinion of the members is calculated to facilitate the carrying on of the activities of the training centre.

#### *Proceedings of the board*

3.—(1) Subject to the provisions of this Act the board may in the exercise of the training centre make standing orders regulating the proceedings of the training centre or of the board, and in the exercise of its powers under this Act, may set out committees in the general interest of the training centre, and make standing orders therefor.

(2) Standing orders shall provide for decisions taken to be unanimous and accordingly the chairman shall not have a second or casting vote. Standing orders made for a committee shall provide that the committee is to report back to the board on any matter not within its competence under this Act to decide.

4. The quorum of the board shall be four of whom one shall be the representative of either the executing agency or of the special fund ; and the quorum of a committee of the board shall be fixed by the board itself.

#### *Meetings*

5.—(1) Subject to the provisions of this Act and any standing orders of the board, the board shall meet whenever it is summoned by the chairman ; and if the chairman is required to do so by notice given him by the Minister, he shall summon a meeting of the board to be held within seven days from the date on which the notice is given.

(2) At any meeting of the board, the chairman shall preside and if he is not present, the members attending may appoint one of their number to be chairman of the meeting.

(3) Where the board desires to obtain advice of any expert on a particular matter touching or concerning the training centre, the board may co-opt him as a member for such period as the board thinks fit ; and a person who is a member by virtue of this sub-paragraph shall not be entitled to vote at any meeting of the board, and shall not count towards a quorum.

(4) Notwithstanding any thing in the foregoing provisions of this paragraph, the first meeting of the board shall be summoned by the Minister, who may give such directions as he thinks fit as to the procedure which shall be followed at the meeting.

*Committees*

- 6.—(1) The board may appoint one or more committees to carry out on behalf of the board such functions as the board may determine.
- (2) A committee appointed under this paragraph shall consist of the number of persons determined by the board.
- (3) A decision of a committee of the board shall be of no effect until it is confirmed by the board.

*Miscellaneous*

- 7.—(1) The fixing of the seal of the training centre shall be authenticated by the signature of the chairman of the board or of the principal officer authorised by the board for that purpose.
- (2) Any contract or instrument which, if made or executed by a person not being a body corporate, would not be required to be under seal, may be made or executed on behalf of the training centre by any person generally or specially authorised to act for that purpose by the board.
- (3) Any document purporting to be a document duly executed under the seal of the training centre shall be received in evidence and shall, unless the contrary is proved, be deemed to be so executed.
8. The validity of any proceedings of the board shall not be affected by any defect in the appointment of a member of the board or of a person to serve on the committee, or by reason that a person not entitled to do so took part in the proceedings.
9. Any member of the board and any person holding office on a committee who has a personal interest in any contract or arrangement entered into or proposed to be considered by the board on behalf of the training centre or on behalf of the board or a committee thereof shall forthwith disclose his interest to the Minister in the case of the training centre or to the chairman of the board, as the case may be, and shall not vote on any question relating to the contract or arrangement.
10. A person shall not by reason only of his membership of the board be treated as holding an office of emolument under the State.

## SECOND SCHEDULE

Section 11 (3)

## TRANSITIONAL PROVISIONS AS TO PROPERTY, ETC.

(1) Every agreement to which the executing agency or the fund under this Act was a party immediately before the appointed day, whether in writing or not and whether or not of such a nature that the rights, liabilities and obligations thereunder could be assumed by the said executing agency shall, unless its terms or subject matter make it impossible that it should have effect as modified in the manner provided by this sub-paragraph, have effect from the appointed day, so far as it relates to property transferred by this Act to the training centre, as if—

(a) the training centre had been a party to the agreement on behalf of the Government of the Federation; and

(b) for any reference (however worded and whether express or implied) to the said executing agency or to the special fund there were substituted, as respects anything falling to be done on or after the appointed transfer day, a reference to the training centre.

(2) Other documents which refer, whether specially or generally, to the executing agency or to the special fund, shall be construed in accordance with sub-paragraph (1) of this paragraph so far as applicable.

(3) Without prejudice to the generality of the foregoing provisions of this Schedule, where, by the operation of any of them or of section 11 of this Act, any right, liability or obligation vests in the training centre, the training centre and all other persons shall, as from the appointed transfer day, have the same rights, powers and remedies as if, in particular, the same rights as to the taking or resisting of legal proceedings or the making or resisting of applications to any authority for ascertaining, perfecting or enforcing that right, liability or obligation as they would have had if it had at all times been a right, liability or obligation of the training centre.

(4) Any application to any authority pending on the appointed transfer day by or against the executing agency under this Act and relating to property transferred by this Act to the training centre may be continued on or after that day by or against the training centre.

(5) If the law in force at the place where any property transferred by this Act is situated provides for the registration of transfers of property of the kind in question (whether by reference to an instrument of transfer or otherwise), the law shall, so far as it provides for alterations of a register (but not for avoidance of transfers the payment of fees or any other matter) apply with the necessary modifications to the transfer of the property aforesaid; and it shall be the duty of the principal to furnish the necessary particulars of the transfer to the proper officer of the registration authority, and of that officer to register the transfer accordingly, and notwithstanding the disclosure of a trust.

GULF OIL COMPANY TRAINING FUND  
(ADMINISTRATION) ACT, 1964



ARRANGEMENT OF SECTIONS

*Section*

- |  |  |
|--|--|
| <p>1. Establishment of the Gulf Oil Company Training Fund.</p> <p>2. Purposes of the fund.</p> | <p>3. Disbursements from the fund.</p> <p>4. Enactment amended.</p> <p>5. Short title and application.</p> |
|--|--|

1964, No. 32

AN ACT TO ESTABLISH AND ADMINISTER A FUND TO BE KNOWN AS THE GULF OIL COMPANY TRAINING FUND AND FOR PURPOSES CONNECTED THEREWITH.

BE IT ENACTED by the Legislature of the Federation of Nigeria in this present Parliament assembled and by the authority of the same as follows:—

[12th October, 1964]

Commence-  
ment.

1. There shall be established a fund to be known as the Gulf Oil Company Training Fund (in this Act hereafter referred to as "the fund") into which shall be paid all moneys received in terms of an agreement made between the said Company and the Government of the Federation that is to say—

Establish-  
ment of the  
Gulf Oil  
Company  
Training  
Fund.

(a) the sum of one hundred and ninety-three thousand, one hundred and thirteen pounds received as part of the moneys so payable; and

(b) any further sums from time to time payable under the said agreement;

and moneys in the fund together with interest (if any) payable in respect thereof shall be applied by the Minister of the government of the Federation responsible for mines and power for any of the purposes set out in section two of this Act.

2. The fund shall be available for purposes of training Nigerians technicians or craftsmen as the case may be in the fields of engineering, science and administration in so far as they relate to the petroleum industry, and to this end the fund may be used—

- (a) to provide scholarships in universities and institutions ;
- (b) to maintain or subsidise any such training ; or
- (c) to make any suitable endowments to faculties in Nigerian universities, Colleges, or approved institutes ; and
- (d) to make available suitable books and training equipment in the aforesaid fields.

3. Disbursements from the fund shall be made in accordance with rules made under section twenty-three of the Finance (Control and Management) Act 1958.

4. The First Schedule to the Finance (Control and Management) Act, 1958, is amended by the insertion immediately after item 11 in Part II of the following item—

“(12) Gulf Oil Company Training Fund :

The fund established by section one of the Gulf Oil Company Training Fund (Administration) Act, 1964, for the purposes specified in section two of that Act.”

5. This Act may be cited as the Gulf Oil Company Training Fund (Administration) Act, 1964, and shall apply throughout the Federation.

# NIGERIAN RESEARCH INSTITUTES ACT, 1964



## ARRANGEMENT OF SECTIONS

### *Section*

- |  |   |
|--|---|
| <ol style="list-style-type: none"> <li>1. Establishment and functions of research institutes.</li> <li>2. Management of affairs of institutes.</li> <li>3. Financial provisions.</li> <li>4. Compulsory acquisition of land for institutes.</li> </ol> | <ol style="list-style-type: none"> <li>5. Application of Pensions Act to employment in the service of institutes etc.</li> <li>6. Annual report.</li> <li>7. Regulations.</li> <li>8. Winding up of existing research institutes and their committees.</li> <li>9. Short title, extent, commencement and interpretation.</li> </ol> <p>SCHEDULE—Constitutions etc. of the councils.</p> |
|--|---|



1964, No. 33

AN ACT TO ESTABLISH RESEARCH INSTITUTES IN RESPECT OF COCOA, COFFEE AND COLA, IN RESPECT OF THE OIL PALM, IN RESPECT OF RUBBER, AND IN RESPECT OF TRYPANOSOMIASIS ; TO PROVIDE FOR THE TRANSFER TO THOSE INSTITUTES OF CERTAIN ASSETS AND LIABILITIES OF EXISTING BODIES (IF ANY) ESTABLISHED FOR SIMILAR PURPOSES AND FOR THE WINDING UP OF THOSE BODIES ; AND FOR PURPOSES CONNECTED WITH THE MATTERS AFORESAID.

[See section 9 (2)]

Commencement.

BE IT ENACTED by the Legislature of the Federation of Nigeria in this present Parliament assembled and by the authority of the same as follows :—

1.—(1) There shall be established four bodies corporate by the following names, that is to say—

- (a) the Cocoa Research Institute of Nigeria ;
- (b) the Nigerian Institute for Oil Palm Research ;
- (c) the Rubber Research Institute of Nigeria ; and
- (d) the Nigerian Institute for Trypanosomiasis Research,

which bodies are hereafter in this Act referred to collectively as “the institutes” and severally as “the Cocoa Institute”, “the Oil Palm Institute”, “the Rubber Institute” and “the Trypanosomiasis Institute” respectively.

(2) The institutes shall be charged with the general duty of undertaking research into and providing information and advice relating to—

- (a) the production and products of cocoa, coffee and cola in the case of the Cocoa Institute ;
- (b) the production and products of oil palm and of such other palms as the Minister may determine in the case of the Oil Palm Institute ;
- (c) the production and products of rubber ; and
- (d) trypanosomiasis in the case of the Trypanosomiasis Institute.

(3) subject to the following provisions of this section, each of the institutes shall have power to do anything which, in the opinion of the institute, is calculated to facilitate the carrying on of the activities of the institute.

(4) Except with the prior approval in writing of the Minister, an institute shall not have power—

- (a) to incur expenditure outside approved estimates under this Act ; or
- (b) to borrow money.

(5) The Minister may from time to time give to an institute directions of a general nature in writing with respect to the performance of its functions ; and it shall be the duty of the institute to comply with the directions.

Establishment and functions of research institutes.

There shall be established for each institute a governing reafter in this Act referred to, in relation to the relevant "the council"), and the provisions of the Schedule to this Act shall have effect, so far as applicable, with respect to the constitutions of the councils and the other matters there mentioned.

The affairs of each institute shall be managed by the council, and the provisions in this Act to the institutes shall be construed accordingly; but nothing falling to be done by or to an institute shall be done to the prejudice of the generality of the foregoing provisions of this Act.

Nothing falling to be done by or to an institute shall be done to the prejudice of the generality of the foregoing provisions of this Act.

Nothing falling to be done by or to an institute shall be done to the prejudice of the generality of the foregoing provisions of this Act.

It shall be the duty of the council of each institute—

- (a) to prepare a programme of research within the field for which the institute is responsible for such periods of not less than three years as the board may, with the approval of the Minister determine, together with detailed estimates of the expenditure which will be required to carry out the programme;
- (b) each year to review, and if necessary revise, the programme approved under paragraph (a) for the following year, together with the estimates of expenditure for that year;
- (c) to submit the programmes and estimates of expenditure, and any annual revisions, for approval by the Minister;
- (d) to carry out the programmes of research approved by the Minister.

(4) There shall be a director for each institute, who shall be appointed by the Minister on the advice of the council and shall be a person with wide experience of the matters with which the relevant institute is concerned; and the director shall—

- (a) be charged with the day to day management of the affairs of the institute in accordance with such instructions as may from time to time be given to him by the council; and
- (b) hold office, subject to the provisions of section five of this Act, in accordance with the terms of the instrument by which he is appointed (including terms as to the payment of his remuneration by the council).

(1) Each of the institutes shall establish and maintain a fund in which there shall be defrayed all expenditure incurred by the institute.

(2) There shall be paid or credited to the fund—

- (a) such sums out of moneys provided by Parliament as Parliament may from time to time determine;

(b) in the case of any institute other than the Trypanosomiasis Institute, such sums out of moneys to be provided by the legislature of each Region or by the appropriate statutory agency of each Region, in accordance with a formula agreed by the several governments and the government of the Federation;

(c) such assets of the relevant institute and committee mentioned in section eight of this Act as are transferred to the institute in pursuance of that section; and

(d) all other assets from time to time accruing to the institute.

(3) The fund shall be managed in accordance with rules made by the Minister and the Minister of the government of the Federation responsible for finance, acting jointly; and, without prejudice to the generality of the power to make rules conferred by this subsection, the rules shall in particular include provision—

(a) specifying the manner in which the assets of the fund are to be held and regulating the making of payments to and from the fund;

(b) requiring the keeping of proper accounts and records for the purposes of the fund in such form as may be specified by the rules;

(c) for securing that the accounts are audited periodically by an auditor appointed by the Ministers aforesaid, acting jointly;

(d) requiring copies of the accounts and of the auditor's report on them to be furnished to the Minister as soon as may be after the end of the period to which the accounts relate; and

(e) requiring the Minister to lay before each House of Parliament copies of all accounts and reports received by him in pursuance of the last foregoing paragraph and, in the case of accounts or reports relating to the Cocoa Institute, the Oil Palm Institute, or the Rubber Institute, to send a copy to the Governor of each Region.

4.—(1) For the purposes of the Public Lands Acquisition Act, the purposes of each of the institutes shall be public purposes of the Federation within the meaning of that Act.

Compulsory  
acquisition  
of land for  
institutes.  
Cap. 167.

(2) The Chief Federal Land Officer may, by an instrument under his hand and seal, vest in the relevant institute any property acquired by the President by virtue of subsection (1) of this section; and the institute shall pay to the Minister of the government of the Federation responsible for finance a sum equal to the aggregate amount of any expenses (including compensation) incurred on behalf of the President by virtue of the said subsection in respect of any property vested in the institute by such an instrument.

5.—(1) The Minister of the government of the Federation responsible for pensions may by order declare that the office of the director of an institute or of any person employed by an institute shall be a pensionable office for the purposes of the Pensions Act; and any order made under an enactment repealed by virtue of this Act declaring that an office under an institute or committee abolished by virtue of this Act is a pensionable office for the purposes of that Act, or of pensions enactments superseded by that Act, shall be deemed to have been duly made in pursuance of this subsection, with effect from the date (if any) specified by the order, in respect of any corresponding office in the service of an institute established by this Act.

Application  
of Pensions  
Act to  
employ-  
ment in the  
service of  
institutes etc.

(2) The Pensions Act shall, in its application by virtue of the foregoing subsection to any office, have effect as if—

(a) the office were an office in the public service of the Federation within the meaning of the Constitution of the Federation ;

(b) the references to the Minister of the government of the Federation responsible for pensions in paragraph (1) of section seven of that Act were references—

(i) in the case of the office of director of an institute, to the Minister ; and

(ii) in any other case, to the council of the relevant institute ; and

(c) section nine of that Act (which relates to compulsory retirement) were omitted.

(3) Nothing in the foregoing provisions of this section shall prevent the appointment of a person to any office on terms which preclude the grant of a pension or gratuity in respect of service in that office.

(4) So much of section seven of the Pensions Act as prevents the grant of benefits under that Act in respect of a person retiring before a specified age shall not apply in relation to the retirement of an expatriate officer within the meaning of that Act who—

(a) retires, either before or after the commencement of this Act, from an office which was or is a pensionable office by virtue of any such order as is mentioned in subsection (1) of this section ; and

(b) held, on or before the first day of October, nineteen hundred and sixty-two, any such office as is mentioned in paragraph (a) of this subsection.

Annual  
report.

6. It shall be the duty of each of the institutes to furnish to the Minister, as soon as may be after the end of each year, a report on the activities of the institute during that year ; and the Minister shall—

(a) lay before each House of Parliament a copy of each report received by him in pursuance of this section ; and

(b) send a copy of each report to the Governor of each Region.

Regulations.

7.—(1) The council of each institute may make regulations generally for its purposes under this Act ; and without prejudice to the generality of the foregoing, regulations may provide for the disciplinary control over the staff of the institute concerned.

(2) Regulations made under the foregoing subsection shall not have effect until they are approved by the Minister and have thereafter been published in the gazette.

Winding up  
of existing  
research  
institutes and  
their committees.  
Caps. 218  
and 219.

8.—(1) The Minister shall by order provide for—

(a) the winding up of the affairs of the institutes and committees established by the West African Institute for Oil Palm Research Act and the West African Institute for Trypanosomiasis Research Act respectively ; and

(b) the winding up as respects Nigeria of the affairs of the institute and committee regulated by the West African Cocoa Research Institute (Nigerian Status) Act, 1950,

No. 6 of  
1950.

and for the transfer of the assets and liabilities of each such institute and committee as aforesaid to the corresponding institute established by this Act; but nothing in this subsection shall be construed as affecting the assets or liabilities of the institute or committee regulated by the said Act of 1950 except to the extent that they arise within Nigeria or by reason of activities carried on or formerly carried on within Nigeria.

(2) An order made in pursuance of subsection (1) of this section may contain such incidental and supplementary provisions as the Minister considers expedient for the purposes of the order.

(3) When it appears to the Minister that the affairs of any institute mentioned in paragraph (a) or (b) of subsection (1) of this section and its committee have been wound up, he shall by order declare the institute and committee to be dissolved on such day as may be specified by the order; and the order—

(a) shall include provision repealing on that day the enactments mentioned in subsection (1) of this section so far as they relate to the institute and committee dissolved by the order; and

(b) may include provision repealing or modifying any other enactment relating to that institute or committee to such extent as the Minister considers expedient in consequence of any other provision made by an order under this section.

9.—(1) This Act may be cited as the Nigerian Research Institutes Act, 1964, and shall apply throughout the Federation.

Short title,  
extent, com-  
mencement  
and interpre-  
tation.

(2) This Act shall come into force on such day as the Minister may by order appoint, and a different day may be appointed in pursuance of this subsection in relation to each of the institutes.

(3) In this Act "the Minister" means—

(a) in relation to institutes other than the Trypanosomiasis Institute, the Minister of the government of the Federation responsible for agricultural research; and

(b) in relation to the Trypanosomiasis Institute, the Minister of the government of the Federation responsible for veterinary research.

## SCHEDULE

Constitutions etc. of the councils

*Membership of the councils*

1.—(1) Subject to the provisions of this Schedule, the council of the Cocoa Institute shall consist of eleven members and comprise—

- (a) two persons appointed by the Minister.
- (b) the director of the institute;
- (c) five persons appointed by the Government of Western Nigeria;
- (d) one person appointed by the Government of Eastern Nigeria;
- (e) one person appointed by the Government of Northern Nigeria;
- (f) one person appointed by the Government of Mid-Western Nigeria;

(2) Subject to the provisions of this Schedule, the council of the Oil Palm Institute shall consist of ten members and comprise—

- (a) two persons appointed by the Minister.
- (b) the director of the institute;
- (c) one person appointed by the Government of Western Nigeria;
- (d) four persons appointed by the Government of Eastern Nigeria;
- (e) one person appointed by the Government of Northern Nigeria;
- (f) one person appointed by the Government of Mid-Western Nigeria.

(3) Subject to the provisions of this Schedule, the council of the Rubber Institute shall consist of ten members and comprise—

- (a) two persons appointed by the Minister.
- (b) the director of the institute;
- (c) one person appointed by the Government of Western Nigeria;
- (d) one person appointed by the Government of Eastern Nigeria;
- (e) one person appointed by the Government of Northern Nigeria;
- (f) four persons appointed by the Government of Mid-Western Nigeria.

(4) Subject to the provisions of this Schedule, the council of the Trypanosomiasis Institute shall consist of eleven members and comprise—

- (a) five persons appointed by the Minister.
- (b) the director of the institute;
- (c) one person appointed by the Government of Western Nigeria;
- (d) one person appointed by the Government of Eastern Nigeria;
- (e) two persons appointed by the Government of Northern Nigeria;
- (f) one person appointed by the Government of Mid-Western Nigeria.

(5) If the Minister responsible for a particular institute is satisfied that persons who are not members ought, by reason of their experience or professional competence to be admitted to membership he may, by notice in the Gazette, appoint as additional members not more than five persons so qualified; and any person so appointed under this sub-paragraph may attend all meetings and take part in any deliberations of the council, but shall not be entitled to vote thereat.

*Tenure of office of members*

2.—(1) Subject to the provisions of this paragraph, a member of a council shall hold office for the period of five years beginning—

(a) in the case of a member appointed to fill a vacancy which has not previously been filled, with the day when this Act comes into force as respects the relevant institute;

(b) in any other case, with the day next following that on which the term of office of his predecessor expires by the effluxion of time or, where the predecessor has previously vacated office, on which it would have so expired.

(2) With a view to securing the retirement in rotation of members appointed as additional members of each council, the Minister may by order provide that the term of office of any three of such members shall be such shorter period as the Minister may from time to time approve, but not less in any particular case than three years.

(3) Where a member ceases to hold office at a time when more than three months of his term of office remain unexpired, the authority who appointed him shall as soon as may be appoint a successor who shall, subject to the following provisions of this paragraph, hold office for the residue of that term.

(4) Without prejudice to the provisions of section eleven of the Interpretation Act, 1964 (which, among other things, provides for the removal of appointees by the persons who appointed them), a member of the council shall cease to hold office if he resigns his office by a notice in writing signed by him and served on the Minister.

(5) A person who ceases to hold office as a member of a council shall be eligible for reappointment as such a member.

(6) References in the foregoing provisions of this paragraph to members of a council do not include references to the director of the relevant institute.

1964, No. 1.

*Proceedings of councils*

3. Subject to the provisions of this Act and of section twenty-six of the Interpretation Act, 1964 (which provides for decisions of a statutory body to be taken by a majority of its members and for the chairman to have a second or casting vote), each council may make standing orders regulating the proceedings of the council or any committee thereof.

4. The quorum of the council shall be five provided that at the meeting there are at least two members present to represent other governments on the council; and the quorum of any committee of a council shall be determined by the council.

5.—(1) The Minister after consultation with the Regional Governments shall appoint the chairman of a council from among its members and every council of its own motion shall elect some other member to be the deputy chairman of the council; so however that notwithstanding the period for which the appointment or election is to have effect, if a chairman or deputy chairman ceases to be a member of the council he shall cease to hold the office to which he was so appointed or elected as the case may be.

(2) At any time while the office of chairman is vacant or the chairman is in the opinion of the council permanently or temporarily unable to perform the functions of his office, the deputy-chairman shall perform those functions, and references in this Schedule to the chairman shall be construed accordingly.

6.—(1) Subject to the provisions of its standing orders, a council shall meet whenever it is summoned by the chairman; and if the chairman is required so to do by notice given to him by not less than four members of the council he shall summon a meeting of the council to be held within twenty-eight days from the date on which the notice is given. If the chairman fails to summon any meeting when so required, the Minister in his discretion may exercise such power.

(2) At any meeting of a council the chairman or in his absence the deputy-chairman shall preside, but if both are absent the members present at the meeting shall elect one of their number to preside at that meeting.

(3) Where a council desires to obtain the advice of any person on a particular matter the council may co-opt him as a member for such period as it thinks fit; but a person who is a member by virtue of this subparagraph shall not be entitled to vote at any meeting of the council and shall not count towards a quorum.

(4) Notwithstanding anything in the foregoing provisions of this paragraph, the first meeting of each council shall be summoned by the Minister, who may give such directions as he thinks fit as to the member who shall preside and the procedure which shall be followed at that meeting.

#### *Committees*

7.—(1) Each council may appoint one or more committees to carry out, on behalf of the council, such of its functions as the council may determine.

(2) A committee appointed under this paragraph shall consist of the number of persons determined by the council, and a person other than a member of the council shall hold office on the committee in accordance with the terms of the instrument by which he is appointed.

(3) A decision of a committee appointed under this paragraph shall be of no effect until it is confirmed by the council.

#### *Officers and servants*

8. Without prejudice to the generality of subsection (3) of section one of this Act but subject to subsections (4) and (5) of that section, each council shall have power—

(a) to appoint such officers and servants of the institute as the council may determine; and

(b) to pay to any officers and servants of the institute such remuneration as the council may determine.

*Miscellaneous*

9. Standing orders made by a council may provide for the payment to any member of the council or other person appointed to a committee of the council of such travelling and subsistence allowances in respect of any periods spent on the business of the council as the council may determine; but, notwithstanding anything in section one of this Act, no other remuneration shall be paid by the council to any such member or other person.

10.—(1) The fixing of the seal of each institute shall be authenticated by the signature of the director or of some other member of the council authorised generally or specially by the council to act for that purpose.

(2) Any document purporting to be a document duly executed under the seal of an institute shall be received in evidence and shall, unless the contrary is proved, be deemed to be so executed.

11. The validity of any proceedings of a council or a committee thereof shall not be affected by any vacancy in the membership of the council or committee, or by any defect in the appointment of a member of the council or of a person to serve on the committee, or by reason that a person not entitled to do so took part in the proceedings.

12. Any member of a council or of a committee of a council who has a personal interest in any contract or arrangement entered into or proposed to be considered by the council or a committee thereof shall forthwith disclose his interest to the council and shall not vote on any question relating to the contract or arrangement.



## LAGOS LOCAL GOVERNMENT ACT, 1964



### ARRANGEMENT OF SECTIONS

*Section*

1. Additional powers in relation to the lists of voters.
2. Restriction on power to acquire etc. certain property.
3. Extended meaning of authorised expenditure.

4. Miscellaneous amendments.
5. Powers validly exercised.
6. Short title, citation, etc.

SCHEDULE—Miscellaneous amendments.



## 1964, No. IV

AN ACT TO AMEND THE LAGOS LOCAL GOVERNMENT ACT 1959 ; AND TO ADAPT SUCH ACT IN CONFORMITY WITH THE CONSTITUTION OF THE FEDERATION

[12th October, 1964]

BE IT ENACTED by the Legislature of the Federation of Nigeria in this present Parliament assembled and by the authority of the same as follows :—

1. In the course of preparation of the official lists of voters for the purposes of an election of the Council under the provisions of the Lagos Local Government Act 1959 (in this Act hereafter referred to as the principal Act), where—

(a) the name of any person has been omitted from, or is inaccurately stated in, any preliminary list that person shall, when making a claim in the prescribed form, give such additional information as to his name, address or occupation as the returning officer may reasonably require to complete the official lists ;

(b) any person qualified under the principal Act to do so, gives notice in the prescribed form of objection to the inclusion to the preliminary list of the name of any other person, he shall send the notice of objection by registered post ;

and the rules referred to in section eighteen of the principal Act and contained with sundry prescribed forms in the First Schedule to that Act, shall in any such case be read and construed so as to give effect to this section accordingly.

2. Where the Council is empowered to accept, hold and administer property for public purposes, the power shall not be deemed to authorise the acceptance, holding or administration of property which is subject to any religious or charitable trust, and section ninety-three of the principal Act (which authorises acceptance etc. of property for public purposes) shall be so construed and have effect.

3. The Fourth Schedule to the principal Act (which relates to sundry special and general purposes of expenditure) is amended by the insertion immediately after item 10, of the following new items—

“11. Advances for the purchase of motor vehicles, motor cycles and bicycles to officers of the Council for the efficient performance of their duties.

“12. Advances to officers of the Council under the staff housing scheme of the Council.

“13. Allowances to officers and members of the Council for attendance at any conference or meeting of a joint committee, joint board, joint authority or other similar organisation.”

4. The principal Act is further amended to the extent set out in the Schedule to this Act.

Comment.

Additional powers in relation to the lists of voters. 1959 Repr p. D 199.

Restriction on power to acquire certain property.

Extended meaning of authorised expenditure.

Minor amendments.

Powers  
validly  
exercised.

5. It is hereby declared for the avoidance of doubt that the amendments made by this Act shall, in so far as they affect or relate to any of the Schedules to the principal Act, have effect notwithstanding any different provision made by section one hundred and eighty-three of the principal Act.

Short title,  
citation etc.  
1959 Reprint  
p. D 199  
1963 No. V.

6.—(1) This Act may be cited as the Lagos Local Government Act, 1964 and this Act and the principal Act, as affected by the City of Lagos Act, 1963, may be cited together as the Lagos Local Government Acts 1959 to 1964.

(2) This Act shall apply to the Federal territory.

## SCHEDULE

## Section 4

### Miscellaneous Amendments

#### Section 2

(a) In the definition of—

“land” for the word “Crown” where it twice occurs there shall be substituted the word “State”

“trunk road” for the words “the Governor-General” there shall be substituted “Parliament in the case of a federal trunk road or the Minister in any other case,”

(b) Insert in alphabetical sequence the following definition—  
“Minister” means the Minister of Lagos Affairs ;

#### Section 3

For the expression “Governor-General in Council” there shall be substituted “Council of Ministers”

#### Section 4

For the expression “Governor-General in Council” where it occurs in the subsections there shall be substituted the word “Minister”

#### Section 5

(a) For the expression “Governor-General in Council” where it thrice occurs there shall be substituted the word “Minister”

(b) For the reference in paragraph (e) to Crown land there shall be substituted a reference to State land

#### Section 7

For the expression “Governor-General in Council” where it occurs therein there shall be substituted “Minister”

#### Section 8

All words from the commencement up to “Lagos” shall be repealed and there shall be substituted “There may, in and for the city of Lagos, be appointed by the proper authority, by notice in the Gazette”

SCHEDULE—*continued**Section 9A*

(a) For the words "Governor-General" there shall be substituted the word "Minister"

(b) For the avoidance of doubt it is declared that the word "Municipal" where it occurs in paragraphs (b) and (c) is affected by the provisions of the City of Lagos Act 1963 and the word "city" is accordingly substituted therefor in those paragraphs

*Section 13*

For "Governor-General" where it occurs therein there shall be substituted the words "Council of Ministers"

*Section 14*

For the expression "Governor-General in Council" there shall be substituted "President of the Republic"

*Section 15*

For the expression "Governor-General in Council" where it occurs therein there shall be substituted "Minister"

*Section 17*

In subsection (1) in paragraph (b) there shall be substituted for the words "British subject or a British protected person" the words "citizen of Nigeria"

In subsection (2) in paragraph (b) all words after "has" where it first occurs up to "jurisdiction" shall be omitted.

*Section 19*

(a) All words from the commencement up to "appoint" shall be repealed and there shall be substituted "There may for the purposes of an election under this Act be appointed": and

(b) In paragraph (d) thereof for the expression "Governor-General in Council" there shall be substituted the word "Minister"

*Section 20*

All words from the commencement up to "arise and" shall be repealed and there shall be substituted the words "There shall also be appointed a chief registration officer and a returning officer as occasion may arise and any such appointment"

*Section 27*

In paragraph (a) there shall be substituted for the words "British subject or British protected person" the words "citizen of Nigeria"

*Section 31*

In subsection (3)—

(a) in paragraph (c) all words after "peace" up to the end of the paragraph shall be repealed, and

(b) paragraph (e) shall be omitted.

(b) of providing in accordance with those provisions such services as in the opinion of the board are usually provided by national libraries of the highest standing.

(2) For the purpose of carrying out the general functions imposed on the board by the foregoing subsection, it shall be the duty of the board, so far as its resources permit—

(a) to assemble, maintain and extend a collection of books, periodicals, pamphlets, newspapers, maps, musical scores, films and recordings and such other matter as the board considers appropriate for a library of the highest standing ;

(b) to establish and maintain such branches of the library as the board considers expedient ;

(c) to make the facilities of the library available to members of the public and others on proper terms (which may include provision for the payment of fees, for safeguarding the property of the board and for specifying the categories of persons who may be admitted to premises under the control of the board) ;

(d) to make such arrangements as the board considers appropriate with respect to—

(i) the exchange of matter included in the collection aforesaid ;

(ii) the preparation and publication of catalogues, indices and similar aids ; and

(iii) the provision of assistance to other persons in the organisation of libraries and with respect to the manner of using facilities under the control of libraries ; and

(e) to make to the official in charge of any department of the government of the Federation by which a library is maintained for the purposes of the department recommendations with respect to the organisation of, and the use of facilities provided by, that library.

(3) The provisions of the Schedule to this Act shall have effect with respect to the constitution and procedure of the board and the other matters there mentioned.

The director  
of the  
library.

2.—(1) There shall be a director of the library (hereafter in this Act referred to as “the director”) who, subject to the provisions of subsection (2) of this section, shall be appointed by the board and shall be a person appearing to the board to have shown exceptional capacity in the organisation and administration of a library and services comparable to those envisaged by this Act.

(2) A person shall not be appointed as the director unless his appointment is approved by the Minister.

(3) The director shall hold and vacate office in accordance with the terms of the instrument by which he is appointed.

(4) The director shall, subject to any instructions given in pursuance of subsection (5) of this section, have the general function of organising and managing the library and services provided in pursuance of this Act, and in particular the function of directing the activities of the officers and servants of the board.

(5) The board may give the director instructions with regard to the exercise of his functions, and it shall be the duty of the director to comply with the instructions.

3.—(1) Subject to the following provisions of this section, the board shall have power to do anything which in its opinion is calculated to facilitate the carrying on of its activities.

Powers of the board.

(2) Except with the approval of the Minister, the board shall not have power to borrow money or to dispose of any land or minerals.

(3) Subject to the provisions of the Schedule to this Act relating to travelling and subsistence allowances, no remuneration shall be paid by the board to any member of the board other than the director.

(4) The Minister may give the board directions of a general character or relating generally to particular matters (but not to any individual person or case) with regard to the exercise by the board of its functions, and it shall be the duty of the board to comply with the directions.

4.—(1) The board shall submit to the Minister, not later than the thirty-first day of December of the year in which this Act comes into force and of each subsequent year, an estimate of its expenditure and income during the next succeeding financial year; and it shall be the duty of the director to prepare for the consideration of the board the estimates which in his opinion it would be appropriate for the board to submit to the Minister in pursuance of this subsection.

Financial provisions.

(2) The board shall keep proper accounts in respect of each financial year and proper records in relation to those accounts, and shall cause its accounts to be audited as soon as may be after the end of the financial year to which the accounts relate by a firm of auditors approved, as respects that year, by the Minister of the government of the Federation responsible for finance.

(3) The Minister may, out of moneys provided by Parliament, make to the board either by way of grant or by way of loan payments of such amounts as Parliament may from time to time determine.

5.—(1) The board shall prepare and submit to the Minister, not later than the thirtieth day of May of the year next following that in which this Act comes into force and of each subsequent year, a report in such form as the Minister may direct on the activities of the board during the last preceding financial year, and shall include in the report a copy of the audited accounts of the board for that financial year and of the auditor's report on the accounts.

Annual reports, etc.

(2) The Minister shall cause a copy of each report made to him under this section to be laid before each House of Parliament.

(3) For the purposes of the board's first report under this section, the last preceding financial year shall be deemed to include so much of any period before the beginning of that year as begins with the date of the first meeting of the board.

(4) Notwithstanding anything in subsection (4) of section three of this Act, the Minister may, by notice in writing served on the director, require the board to furnish the Minister with all information within its power relating to such matters connected with an activity of the board as may be specified by the notice; and it shall be the duty of the board to comply with the requirements of the notice.

Furnishing of publications by government departments.

6. Where any printed matter (other than matter of such descriptions as the director may specify from time to time) is published by or on behalf of any department of the government of the Federation, it shall be the duty of the official in charge of the department to deliver forthwith to the director, for the purposes of the library maintained in pursuance of this Act, fifty copies of the publication or such smaller number of copies of the publication as the director may determine in any particular case.

Short title, extent and commencement, etc.

7.—(1) This Act may be cited as the National Library Act, 1964, and shall apply to the Federal territory only.

(2) This Act shall come into force on such date as the Minister may by order appoint.

(3) In this Act, except where the context otherwise requires, "the Minister" means the Minister of the government of the Federation responsible for libraries.

## SCHEDULE

Section 1.

Supplementary provisions relating to the board

### *Membership of the board*

1.—(1) Subject to the provisions of this Schedule, the board shall consist of twelve members of whom one shall be the director and the others shall be appointed by the Minister and shall comprise—

(a) five persons who shall severally be persons appearing to the Minister to have wide experience of the functions of libraries in the following fields respectively, that is to say—

(i) newspapers, broadcasting and other media of mass communication ;

(ii) university education and research ;

(iii) education other than university education ;

(iv) law ;

(v) the activities of legislatures ;

(b) four persons who shall severally be persons appearing to the Minister, after consultation with such authorities of each Region as he considers appropriate in the case of each of those persons respectively, to have a wide knowledge of the requirements of that Region with respect to libraries ; and

(c) one person who shall be a person appearing to the Minister to have wide experience in the handling of financial problems connected with the provision of public services ; and

(d) one person who shall be a person appearing to the Minister to represent the interests of any body or association of librarians established in Nigeria.

(2) The Minister shall nominate one of the members of the board appointed by him to be the chairman of the board.

*Tenure of office of members*

2.—(1) Subject to the provisions of this paragraph, a member of the board shall hold office for the period of three years beginning—

(a) in the case of a member appointed to fill a vacancy which has not previously been filled, with the date of the commencement of this Act ;

(b) in any other case, with the date next following that on which the term of office of his predecessor expires by the effluxion of time or, where the predecessor has previously vacated office, on which it would have so expired.

(2) With a view to securing the retirement in rotation of members of the board, the Minister may by order provide that the term of office of any four of the persons mentioned in paragraph (a) of the foregoing subparagraph shall be one year, and that the term of office of any other four of those persons shall be two years.

(3) Where a member ceases to hold office at a time when more than three months of his term of office remain unexpired, the Minister shall as soon as may be appoint a successor who shall, subject to the following provisions of this paragraph, hold office for the residue of that term.

(4) Without prejudice to the provisions of section eleven of the Interpretation Act, 1964 (which, among other things, provides for the removal of appointees by the persons who appointed them), a member of the board shall cease to hold office if he resigns his office by a notice in writing signed by him and served on the Minister.

1964, No. 1.

(5) A person who ceases to hold office as a member of the board (other than a person who, after less than one year in office, so ceases in pursuance of subparagraph (3) of this paragraph on the expiration of the residue of his predecessor's term) shall not be eligible for reappointment as a member during the period of three years beginning with the day on which he so ceases.

(6) References in the foregoing provisions of this paragraph to members of the board do not include references to the director.

*Proceedings of the board*

3. Subject to the provisions of this Act and of section twenty-six of the Interpretation Act, 1964 (which provides for decisions of a statutory body to be taken by a majority of its members and for the chairman to have a second or casting vote), the board may make standing orders regulating the proceedings of the board or any committee thereof.

4. The quorum of the board shall be five, and the quorum of any committee of the board shall be determined by the board.

5.—(1) The board shall elect a member of the board to be the deputy-chairman of the board for such period as the board may determine, so however that a deputy-chairman who ceases to be a member shall cease to be deputy-chairman.

(2) At any time while the office of chairman is vacant or the chairman is in the opinion of the board permanently or temporarily unable to perform the functions of his office, the deputy-chairman shall perform those functions, and references in this Schedule to the chairman shall be construed accordingly.

6.—(1) Subject to the provisions of any standing orders of the board, the board shall meet whenever it is summoned by the chairman ; and if the chairman is required so to do by notice given to him by not less than six other members, he shall summon a meeting of the board to be held within seven days from the date on which the notice is given.

(2) At any meeting of the board the chairman or in his absence the deputy-chairman shall preside, but if both are absent the members present at the meeting shall elect one of their number to preside at that meeting.

(3) Where the board desires to obtain the advice of any person on a particular matter, the board may co-opt him as a member for such period as it thinks fit ; but a person who is a member by virtue of this subparagraph shall not be entitled to vote at any meeting of the board and shall not count towards a quorum.

(4) Notwithstanding anything in the foregoing provisions of this paragraph, the first meeting of the board shall be summoned by the Minister, who may give such directions as he thinks fit as to the member who shall preside and the procedure which shall be followed at that meeting.

#### *Committees*

7.—(1) The board may appoint one or more committees to carry out, on behalf of the board, such of its functions as the board may determine.

(2) A committee appointed under this paragraph shall consist of the number of persons determined by the board, and not more than one-third of those persons may be persons who are not members of the board ; and a person other than a member of the board shall hold office on the committee in accordance with the terms of the instrument by which he is appointed.

(3) A decision of a committee appointed under this paragraph shall be of no effect until it is confirmed by the board.

#### *Officers and servants*

8. Without prejudice to the generality of subsection (1) of section three of this Act but subject to the other provisions of that section, the board shall have power—

(a) to appoint such officers and servants as the board may determine ;

(b) to pay to any member or any other person appointed to a committee of the board such travelling and subsistence allowances while on any business of the board as the board may determine ;

(c) to pay to the director and to any officer or servant of the board such remuneration as the board may determine; and

(d) as regards the director and any officer or servant of the board in whose case it may determine to do so, to pay to or in respect of them such pensions and gratuities, or to provide and maintain for them such superannuation schemes (whether contributory or not), as the board may determine.

#### Miscellaneous

9.—(1) The fixing of the seal of the board shall be authenticated by the signature of the chairman or of some other member of the board authorised generally or specially by the board to act for that purpose.

(2) Any contract or instrument which, if made or executed by a person not being a body corporate, would not be required to be under seal may be made or executed on behalf of the board by any person generally or specially authorised to act for that purpose by the board.

(3) Any document purporting to be a document duly executed under the seal of the board shall be received in evidence and shall, unless the contrary is proved, be deemed to be so executed.

10. The validity of any proceedings of the board or a committee thereof shall not be affected by any vacancy in the membership of the board or committee, or by any defect in the appointment of a member of the board or of a person to serve on the committee, or by reason that a person not entitled to do so took part in the proceedings.

11. Any member of the board, and any person holding office on a committee of the board, who has a personal interest in any contract or arrangement entered into or proposed to be considered by the board or a committee thereof shall forthwith disclose his interest to the board and shall not vote on any question relating to the contract or arrangement.



# CASINO LICENSING ACT, 1964



## ARRANGEMENT OF SECTIONS

### *Section*

- |   |  |
|---|--|
| 1. Power of Minister to license, etc., a casino.        | 5. Inspection of premises by police.                 |
| 2. Security for performance by licensee of obligations. | 6. Offences.   |
| 3. Notice of licensed premises to be displayed.         | 7. Interpretation.                                   |
| 4. Power of Minister to require information.            | 8. Short title, application and commencement.        |
|   | SCHEDULE—Provisions applicable in respect of casino. |



AN ACT TO MAKE PROVISION FOR THE LICENSING AND CONTROL OF A CASINO IN THE FEDERAL TERRITORY AND FOR CONNECTED PURPOSES.

[See Section 8 (2)]

Commencement.

BE IT ENACTED by the Legislature of the Federation of Nigeria in this present Parliament assembled and by the authority of the same as follows :—

Power of Minister to license, etc. a casino.

1.—(1) It shall be lawful for the Minister by licence under his hand and in such form as he may approve, to authorise any person approved by the Council of Ministers to establish in the Federal territory and operate therein a casino for such period or periods as may be prescribed, anything in any enactment to the contrary notwithstanding.

(2) A casino licensed under the foregoing subsection shall be established in such locality as the Minister may approve and shall be operated only as a proprietary club of the licensee ; and the provisions of the Schedule to this Act shall apply to such proprietary club, so however, that the Minister with the approval of the Council of Ministers may by order at any time add to, amend, vary, or revoke such provisions, or any of them.

(3) Regulations may prescribe—

(a) the terms and conditions under which the licence may be issued and the duration of the licence ;

(b) the conditions subject to compliance with which the licence may be renewed, amended, varied, or transferred ;

(c) the fees payable on application for and issue of the licence ;

(d) the games to be played in the casino, and where applicable, the maximum percentage of commission to be taken by the licensee in respect of each game, and the maximum odds to be paid by the licensee ;

(e) the minimum reserve fund in cash to be held on any one night by the licensee in the casino ;

(f) the conditions subject to which persons may be admitted to the casino ;

(g) the measures to be taken for the prevention of fraud on players or on the licensee ;

(h) penalties for breach of the regulations not exceeding fifty pounds or imprisonment for three months, or both.

(4) Orders and regulations made under the foregoing provisions of this section shall be laid before both Houses of Parliament on any of the next twenty sitting days after they are made, and if then annulled shall cease to have effect on the day next following the annulment, but without prejudice to anything done or purported to have been done under any such orders or regulations.

(5) A licence under this section may be revoked—

(a) if upon complaint by the Inspector-General of Police to the Minister, the Council of Ministers are satisfied that it is a proper case for such action and direct accordingly ;

(b) if the Council of Ministers are satisfied it is in the public interest to revoke the licence ; or

(c) if the Minister is satisfied that a court of competent jurisdiction not lower than one presided over by a chief magistrate so recommends in the course of any criminal proceeding.

Security for performance by licensee of obligations.

2.—(1) The Minister may require the licensee to deposit with him as security for the due performance of any obligation of the licensee under this or any other Act an amount as may be agreed between the licensee and the Minister not less in any event than two hundred pounds; and if default is made in such performance by the licensee, the Minister may in his discretion—

(a) if the obligation can be satisfied by the payment of money, notify the licensee that he intends to apply the money so held as security in satisfaction or part satisfaction, as the case may be, of such obligation ; or

(b) arrange with the Council of Ministers for the licence to be revoked.

(2) Moneys used to satisfy an obligation under the foregoing subsection shall, if the Minister so directs, be replaced by the licensee to the extent necessary to bring the amount held on deposit up to the original sum.

Notice of licensed premises to be displayed.

3. The licensee shall cause to be prominently displayed in the casino a notice that the premises are so licensed ; and the notice shall show the games authorised to be played, and as the case may be, the maximum percentage of commission to be deducted in play, and the odds payable.

Power of Minister to require information.

4. The licensee shall at intervals of not more than six months after the commencement of his licence supply to the Minister such information relating to the operation of the casino as may be reasonably necessary to ensure due compliance by the licensee with the requirements of the licence.

Inspection of premises by police.

5. A superior police officer in uniform may, during the course of any play, enter upon the premises occupied by the licensee under this Act ; and, if he has reasonable cause to suspect that they are not used or operated in the prescribed manner, he may search any part of the premises.

Offences.

6.—(1) If a licence is granted under this Act, no person other than the licensee shall be entitled to use the word "casino" in conjunction with his name ; and the failure to comply with the requirement of this section shall be an offence punishable by conviction—

(a) in the case of a body corporate by a fine of not less than five hundred pounds ;

(b) in any other case, by a fine of not less than one hundred pounds or more than two hundred pounds or by imprisonment of a term of one year, or both such fine and imprisonment ; and the court convicting shall order the offending name to be changed forthwith.

(2) Any person not duly licensed under this Act, who falsely represents himself to be so licensed, shall be guilty of an offence and liable on conviction—

(a) in the case of a body corporate to a fine of not less than five hundred pounds or more than one thousand pounds ;

(b) in any other case to a fine of not less than two hundred pounds or more than five hundred pounds, or imprisonment for a term of two years or both such fine and imprisonment.

7. In this Act unless the context otherwise requires—

“casino” means any building or part of a building licensed under this Act to which members of the public authorised by the licensee have access for the purpose, among other things, of playing at prescribed games of chance ;

“licence” means a licence issued under section one of this Act ;

“the Minister” means the Minister of the Government of the Federation charged with responsibility for Internal Affairs ;

“prescribed” means prescribed by this Act or by regulations made by the Minister under this Act.

Interpretation.

8.—(1) This Act may be cited as the Casino Licensing Act, 1964 and shall apply to the Federal territory.

(2) This Act shall come into force on a day to be appointed by the Minister by notice in the gazette.

Short title, application and commencement.

## SCHEDULE

### Section 1

#### PROVISIONS APPLICABLE IN RESPECT OF A CASINO

1. The rules of the club may provide for permanent and temporary membership and they shall be approved by the Minister.

2. The licensee shall fix an amount to be known as the minimum income and persons resident in Nigeria other than those in the categories shall be admitted to such membership and to play subject to proof to the satisfaction of the licensee that any such applicant is in receipt of at least the minimum income in respect of any consecutive period of twelve months preceding the date of application for membership.

3. Persons of the following categories shall not while in the Federal territory be eligible for membership of the club, namely :—

(a) persons serving in the armed forces of the Federation ;

(b) persons serving in the Nigeria Police Force or in any local government or native authority police force ;

(c) members (including presidents) of any court of law in the Federation ;

(d) officers of the public service of the Federation, or of any Region ;

(e) officers or servants of any local government council, native authority, or body corporate directly established by any law enacted by any legislature, in the Federation.



\*L.N. 126 of 1964

## REGISTRATION OF TITLES ACT (CAP. 181)

## Registration of Titles (Application) Order, 1964

Commencement : 9th October, 1964

In exercise of the powers conferred by subsection 1 of section 2 of the Registration of Titles Act and of all other powers enabling me in that behalf, I hereby make the following Order—

This Order may be cited as the Registration of Titles (Application) Order, 1964 and shall apply to the area specified in the Schedule hereto.

Citation and application.

## SCHEDULE

All that parcel of land at Surulere, Yaba West, Ebute Metta West and Abule-Nla on the Mainland of the Federal Territory the boundaries of which are described below :

Starting at a concrete pillar marked LD6544 the co-ordinates of which are 5,885.15 feet south and 7,895.21 feet west of a concrete pillar marked LCS165P, the origin of Lagos Cadastral Surveys the boundaries run in straight lines, the bearings and lengths of which are as follows :—

From	Bearings	Lengths	To
LD6544	111° 22'	483.6 feet	LD6543
LD6543	111° 22'	660.0 feet	LD6542
LD6542	58° 48'	185.5 feet	C.P.
C.P.	75° 55'	44.9 feet	EA2268
EA2268	30° 34'	64.3 feet	EA2267
EA2267	36° 08'	264.7 feet	EA2266
EA2266	49° 01'	137.6 feet	EA2265
EA2265	28° 34'	82.2 feet	EA2264
EA2264	49° 51'	233.5 feet	EA2263
EA2263	341° 43'	209.7 feet	EA2262
EA2262	357° 51'	109.7 feet	EA2261
EA2261	29° 10'	179.8 feet	EA2260
EA2260	1° 24'	51.5 feet	KE364
KE364	75° 44'	4,092.2 feet	LCS1487S
LCS1487S	68° 47'	3,055.4 feet	LCS1477S

Thence southwards along Clifford Street to Lagos Street; thence westwards (into the Railway Compound) on a bearing of 245° 00' for a distance of 1,074 feet; thence on a bearing of 156° 15' for a distance of 346 feet; thence on a bearing of 244° 30' for a distance of 706 feet to Thomas Street; thence along Thomas Street on a bearing of 156° 00' for a distance of 348 feet to PBL 2311 on its junction with Ibadan Street West; thence along Ibadan Street West on a bearing of 244° 00' for a distance of 350 feet; thence along Babani Street on a bearing of 155° 00' for a distance of 338 feet to a concrete pillar marked PBL 3860; thence on a bearing of 164° 12' at a distance of 17.0 feet to PBL 3859 on the junction of Apapa Road with

Babani Street; thence westwards along Apapa Road to its junction with Western Avenue; thence westwards along Apapa Road to its junction with Abebe (Iganmu) Road level crossing. Thence along Abebe (Iganmu) Road to a concrete pillar marked LCS 552P

<i>From</i>	<i>Bearings</i>	<i>Lengths</i>	<i>To</i>
552P	269° 40'	232.2 feet	553P
553P	296° 44'	598.0 feet	544P
554P	276° 20'	252.5 feet	555P
555P	245° 18'	266.4 feet	556P
556P	263° 21'	179.9 feet	557P
557P	248° 43'	168.5 feet	558P
558P	282° 57'	188.3 feet	559P
559P	293° 05'	275.2 feet	560P
560P	268° 21'	260.2 feet	561P

Thence southwards on a bearing of 180° 00' and an approximate distance of 671.5 feet to the edge of the swamp. Thence along the edge of the swamp in a zig-zag direction to a point P61 on the Federal Territory boundary.

<i>From</i>	<i>Bearings</i>	<i>Lengths</i>	<i>To</i>
P61	0° 00'	533.7 feet	PBC3646
PBC3646	0° 00'	1,058.1 feet	PBC3645
PBC3645	0° 00'	444.1 feet	PBC3644
PBC3644	0° 00'	1,229.4 feet	PBC3643
PBC3643	0° 00'	899.7 feet	LCS465P
LCS465P	0° 00'	292.1 feet	LCS464P
LCS464P	0° 00'	340.0 feet	LCS463P
LCS463P	0° 00'	580.5 feet	LD6544 (the starting point).

MADE in Lagos this 4th day of November, 1964.

MUSA YAR'ADUA,  
*Minister of Lagos Affairs*

#### EXPLANATORY NOTE

This Order extends the application of the Registration of Titles Act to certain parts of the Lagos Mainland not already within the ambit of the Act.

\*NOTE:—The above Legal Notice cancels L.N. 126 of 1964 published in the Supplement to the Federal Republic of Nigeria Official Gazette No. 91, Vol. 51 of 12-11-64.

L.N. 128 of 1964

**INDUSTRIAL DEVELOPMENT (INCOME TAX RELIEF) ACT  
(CHAPTER 87)**

**Industrial Development (Income Tax Relief)  
(Dry Cell Batteries) Order, 1964**

*Commencement : 16th November, 1964*

WHEREAS a representation has been received pursuant to subsection (1) of section 3 of the Industrial Development (Income Tax Relief) Act for the making of an Order declaring the industry and the product set out in the Schedule to this Order to be a pioneer industry and pioneer product :

AND WHEREAS all necessary steps have been taken pursuant to subsections (1) and (2) of section 3 of the said Act, prior to the making of this Order :

NOW THEREFORE, in exercise of the powers conferred by subsection (2) of section 3 of the Industrial Development (Income Tax Relief) Act, and of all other powers enabling him in that behalf, the President hereby makes the following Order :—

(1) This Order may be cited as the Industrial Development (Income Tax Relief) (Dry Cell Batteries) Order, 1964 and shall be of Federal application.

Citation and application.

(2) The industry and its product set out in the Schedule hereto are hereby declared as a pioneer industry and a pioneer product respectively.

Declaration of pioneer industry and pioneer product.

**SCHEDULE**

<i>Industry</i>	<i>Product</i>
The manufacture/assembly of dry cell batteries	Dry Cell Batteries

MADE this 16th day of November, 1964.

R. C. ONYEJEU,  
*Acting Deputy Secretary to the  
Council of Ministers*

**EXPLANATORY NOTE**

The purpose of this Order is to declare the manufacture and assembly of dry cell batteries and its product pioneer industry and pioneer product respectively.

I.2609

L.N. 129 of 1964

EXPORT OF NIGERIAN PRODUCE ACT 1958  
(1958 No. 36)

Export of Nigerian Produce (Prescribed Grades and  
Standards) (Amendment) Regulations 1964

*Commencement : 26th November, 1964*

In exercise of the powers conferred by Section 3 (a) of the Export of Nigerian Produce Act 1958 and of all other powers enabling me in that behalf, I hereby make the following Regulations :—

Citation  
and  
application.

1. These regulations may be cited as the Export of Nigerian Produce (Prescribed Grades and Standards) (Amendment) Regulations 1964, and shall apply throughout the Federation.

Amendment  
of L.N. 230  
of 1959.

2. The Standards prescribed in Regulation 2 of the Export of Nigerian Produce (Prescribed Grades and Standards) Regulations 1959 as amended by the Export of Nigerian Produce (Prescribed Grades and Standards) (Amendment) Regulations 1961 for grades of seed cotton, are further amended by the addition of the following new grade immediately after the prescription for Grade N.A. 2. :—

“GRADE N.A. 3

American seed cotton grown in Nigeria from approved seed which as regards freedom from immature seed cotton, damaged or stained seed cotton, insects, leaf trash, stalk and mineral matter does not qualify for Grade N.A. 1 or Grade N.A. 2, but still conforms to the current standard sample for Grade N.A. 3, and is entirely free from foreign fibre and added moisture”.

MADE at Lagos this 24th day of November, 1964.

Z. B. DIPCHARIMA,  
*Federal Minister of Commerce and Industry*

EXPLANATORY NOTE

Northern Nigerian Marketing Board has by a resolution taken on 14th-15th July, 1964 decided to re-introduce three grades of Seed Cotton. The resolution has been accepted by the Nigerian Produce Marketing Company Limited and the Eastern and Western Regional Marketing Boards. These regulations add the third grade to the existing ones.







Supplement to Official Gazette Extraordinary No. 95, Vol. 51, 27th November, 1964—Part B  
L.N. 130 of 1964

EXCISE TARIFF ACT, 1958  
(No. 58 OF 1958)

Excise Tariff (Duties) (No. 3) Order, 1964  
Commencement : 27th November, 1964

In exercise of the powers conferred by subsection (1) of section 3 of the Excise Tariff Act, 1958, the President has made the following Order—

1. This Order may be cited as the Excise Tariff (Duties) (No. 3) Order, 1964, and shall apply throughout the Federation.

Citation and Application.

2. The Schedule to the Excise Tariff Act, 1958, as the same was replaced by the Excise Tariff (Duties) (No. 2) Order, 1964, is amended—

Amendment of the Schedule to No. 58 of 1958 L.N. 92 of 1964.

(a) by the deletion of item 14 and the substitution therefor of the following :—

“14. Paint, including enamel paint ; lacquers, varnishes, distempers, putty, painter’s fillings, and stop- ping, sealing and similar mastics including resin mastics and cements	.. .. . the pound	.. 0 0 2”
---	-------------------	-----------

£ s d

(b) by the deletion of sub-item (1) of item 15 and the substitution therefor of the following :—

“(1) Interlock fabrics :—

(a) for use in the manufacture of excisable goods by a manufacturer approved in that behalf by the Minister	.. .. . the pound	.. 0 0 3
(b) Other	.. .. . the pound	.. 0 2 0”

(c) by the deletion of item 17 and the substitution therefor of the following :—

“17. Soap and Soap products in-  
cluding detergents, whether  
manufactured from soap or  
not .. .. . 5 per centum of the selling  
price.”

(d) by the deletion of the expression “Yarns and” in item 22.

MADE at Lagos this 26th day of November, 1964.

R. C. ONYEJEFU,  
Acting Deputy Secretary to the  
Council of Ministers

EXPLANATORY NOTES

This Order has the following effects—

- (a) Restricts 3d the pound for interlock fabrics to approved manufacturers of excisable goods, and prescribes 2s the pound for other users.
- (b) Extends the imposition at 5 per centum of the selling price on soap and soap products to detergents whether manufactured from soap or not.
- (c) Abolishes the excise duty on yarns.
- (d) Rationalises the item for paint.

L.N. 131 of 1964

CUSTOMS TARIFF ACT, 1958

(No. 60 OF 1958)

Customs Tariff (Duties and Exemptions) (No. 8) Order 1964

Commencement : 27th November, 1964

In exercise of the powers conferred by subsection (1) of section 6 of the Customs Tariff Act, 1958, the President has made the following Order—

1. This Order may be cited as the Customs Tariff (Duties and Exemptions) (No. 8) Order, 1964, and shall apply throughout the Federation.

2. The First Schedule to the Customs Tariff Act, 1958 (which relates to the import duties of Customs) as the same was replaced by the Customs Tariff (Duties and Exemptions) (No. 7) Order, 1964, is amended—

(a) by the insertion of the following immediately after sub-item (4) of item 3 :—

“(4A) Robes, professional, of judges, law officers, magistrates and all officers of the Nigeria Civil Service who are barristers-at-law.. .. *ad valorem 10 per centum*”

(b) by the deletion of sub-item (6) of item 3.

(c) by the deletion of the word “undervest” in sub-item (7) (a) of item 3.

(d) by the insertion of the following in sub-item (7) of item 3 :—

“(c) Singlets .. .. each .. .. 0 3 6  
or *ad valorem 40 per centum*  
whichever is the higher.”

(e) by the deletion of item 5 and the substitution therefor of the following :—

“5. BAGS and SACKS (other than bags loosely sewn) of textile material :—

(1) Of jute with dimensions not exceeding 44 inches by 28 inches shown to the satisfaction of the Board to be imported for the packing of goods each .. .. 0 0 2

Short title and application. Amendment of First Schedule to No. 60 of 1958. L.N. 91 1964.

## EXPLANATORY NOTES

This Order has the following effects—

- (a) Restricts 3d the pound for interlock fabrics to approved manufacturers of excisable goods, and prescribes 2s the pound for other users.
- (b) Extends the imposition at 5 per centum of the selling price on soap and soap products to detergents whether manufactured from soap or not.
- (c) Abolishes the excise duty on yarns.
- (d) Rationalises the item for paint.

L.N. 131 of 1964

CUSTOMS TARIFF ACT, 1958

(No. 60 OF 1958)

Customs Tariff (Duties and Exemptions) (No. 8) Order 1964

Commencement : 27th November, 1964

In exercise of the powers conferred by subsection (1) of section 6 of the Customs Tariff Act, 1958, the President has made the following Order—

Short title  
and applica-  
tion.

Amendment  
of First  
Schedule  
to No. 60  
of 1958.  
L.N. 91  
1964.

1. This Order may be cited as the Customs Tariff (Duties and Exemptions) (No. 8) Order, 1964, and shall apply throughout the Federation.

2. The First Schedule to the Customs Tariff Act, 1958 (which relates to the import duties of Customs) as the same was replaced by the Customs Tariff (Duties and Exemptions) (No. 7) Order, 1964, is amended—

(a) by the insertion of the following immediately after sub-item (4) of item 3 :—

“(4A) Robes, professional, of judges, law officers, magistrates and all officers of the Nigeria Civil Service who are barristers-at-law.. .. *ad valorem* 10 per centum”

(b) by the deletion of sub-item (6) of item 3.

(c) by the deletion of the word “undervest” in sub-item (7) (a) of item 3.

(d) by the insertion of the following in sub-item (7) of item 3 :—

“(c) Singlets .. .. . each .. .. . 0 3 6  
or *ad valorem* 40 per centum  
whichever is the higher.”

(e) by the deletion of item 5 and the substitution therefor of the following :—

“5. BAGS and SACKS (other than bags loosely sewn) of textile material :—

(1) Of jute with dimensions not exceeding 44 inches by 28 inches shown to the satisfaction of the Board to be imported for the packing of goods each .. .. . 0 0 2

(2) Other :—

(a) Imported for the packing of goods by an importer approved in that behalf by the Minister .. ..

each .. .. 0 0 2

(b) Other .. ..

each .. .. 0 1 4

or *ad valorem* 33 $\frac{1}{3}$  per centum whichever is the higher."

(f) by the deletion of the expression "the ton £1-15s-0d or *ad valorem* 20 per centum whichever is the higher" in item 14 and the substitution thereof of the expression "the ton £1-0s-0d"

(g) by the insertion of the following immediately after item 24 :—

"24A. FIREARMS, the following :—

Air guns including air rifles ;

shot guns .. .. *ad valorem* 50 per centum."

(h) by the deletion of item 27 and the substitution thereof of the following :—

"Furniture including framed mirrors, ornaments, framed pictures and photographs, and similar articles :—

(1) Metal Office furniture and cabinets ; identifiable parts thereof .. .. *ad valorem* 50 per centum.

(2) Other, including bed mattresses of all materials ; identifiable parts thereof .. .. *ad valorem* 75 per centum."

(i) by the deletion of the expression "and parts thereof" in item 35.

(j) by the deletion of the expression "the Nigerian Electricity Supply Company Ltd." in item 45 (i) (a) and the substitution thereof of the expression "the Nigerian Electricity Supply Corporation Limited."

(k) by the deletion of item 45A and the substitution thereof of the following :—

"45A. PAINTS, including enamel paint ; lacquers, varnishes, distempers, putty, painter's fillings, and stopping, sealing and similar mastics including resin mastics and cements .. ..

the pound .. .. 0 0 10  
or *ad valorem* 33 $\frac{1}{3}$  per centum  
whichever is the higher."

(l) by the deletion of item 46 and the substitution thereof of the following :—

"46. PAPER :—

(1) Kraft paper for use by a manufacturer approved in that behalf by the Minister .. ..

*ad valorem* 10 per centum.

- (2) Paperboard (cardboard) including corrugated cardboard but excluding building board in uncut rectangular sheets of a size not less than 16 inches by 15 inches .. *ad valorem 15 per centum.*
- (3) Printing and writing paper, other than newsprint, namely, plain or composite paper in reels of not less than 9 inches wide, or flat or folded in the original mill ream wrapper of a size not less than 16 inches by 15 inches .. .. . *ad valorem 15 per centum.*
- (4) Toilet .. .. . *ad valorem 33½ per centum.*
- (5) Other paper and paper manufactures .. .. . *ad valorem 25 per centum.*"

(m) by the insertion of the following immediately after item 46 :—

"46A. PARTS, identifiable as such, of machinery, apparatus and appliances but not including machines mainly for domestic use, tanks of iron or steel, toilet machines, weighing machines, vehicles, or internal combustion engines suitable for driving vehicles :

- (1) Agricultural ;
- (2) Cranes, chain pulleys, bucket and gravity conveyors, hoists, mechanical excavators and winches ;
- (3) Dairying ;
- (4) Dental ;
- (5) For use in connection with the preparation of, or prospecting for, any agricultural or forest product of Nigeria ;
- (6) Hand implements and tools-agricultural, horticultural, artisans', labourers' ;
- (7) Horticultural ;
- (8) Industrial and manufacturing, including machine tools ;

(9) Land surveying ;

(10) Mining and for prospecting for mineral oils ;

(11) For water supply, sewerage, drainage or irrigation, the following only—Pipe, piping, tubes, and fittings therefor, other than of cement, asbestos cement or plastic ; pumps rams, lifting gates and hoists ..

*ad valorem 5 per centum.*"

"46B. PARTS, identifiable as such, of machinery, apparatus, appliances and instruments for the generation, measurement, transformation, storage, transmission, distribution of, or lighting by electric power, but not including electroliers, lamps, lamp shades or reflectors, portable batteries, domestic or toilet machines or appliances, electric appliances used in vehicles and internal combustion engines of the kind used as propulsion units for vehicles .. ..

*ad valorem 5 per centum.*"

(n) by the deletion of items (a) and (b) in sub-item (1) of item 49 and the substitution therefor of the following :—

"(a) Cotton fabrics, plain weave, unbleached or bleached, but not mercerized, dyed or otherwise processed .. ..

each .. .. 0 1 3  
*or ad valorem 33 1/3 per centum,*  
whichever is the higher.

(b) Interlock fabrics :—

(1) for use exclusively for the manufacture of excisable goods by a manufacturer approved in that behalf by the Minister the pound

each .. .. 0 3 3  
*or ad valorem 50 per centum,*  
whichever is the higher.

(2) Other .. .. the pound

each .. .. 15 0  
*or ad valorem 50 per centum,*  
whichever is the higher."

(o) by the deletion of the expression "*ad valorem 25 per centum*" in sub-item (3) of item 52 and the substitution thereof of the expression "*ad valorem 33 $\frac{1}{2}$  per centum*".

(p) by the deletion of item 57.

(q) by the deletion of the expression "the hundredweight 2 0 0" in sub-item 2 of item 60 and the substitution thereof of the expression "the hundredweight 3 0 0".

Amendment  
of Second  
Schedule  
to No. 60  
or 1958.  
L.N. 91  
1964.

3. The Second Schedule to the Customs Tariff Act, 1958 (which relates to exemptions from import duty of Customs) as the same was replaced by the Customs Tariff (Duties and Exemptions) (No. 7) Order 1964, is amended—

(a) by the deletion of item 6 and the substitution thereof of the following :—

"6. Articles, the following, for the manufacture of the goods specified, imported by a manufacturer approved in that behalf by the Minister :—

<i>Articles</i>	<i>Goods to be manufactured</i>
(1) Aluminium and aluminium alloys, unwrought	—
(2) Asbestos, crude, washed or ground .. ..	—
(3) Blending agents, flavouring concentrates, and neutral blending alcohol	Potable alcoholic liquor
(4) Bottles, glass, empty ..	Potable alcoholic liquor
(5) Cigarette paper, by the roll .. .. .	Cigarette
(6) Cordage and rope, not less than one quarter ( $\frac{1}{4}$ ) inch diameter, of any materials other than steel	—
(7) Ferro alloys of manganese and silicon in primary forms .. .. .	—
(8) Fire bricks, fire clay, fire cement and furnace cement .. .. .	—
(9) Fluorspar, crude ..	—
(10) Glass, in the mass, the following :—	
frits, powdered vitrite	—

<i>Article</i>	<i>Goods to be Manufactured</i>
(11) Gypsum .. ..	Cement
(12) Iron and steel, namely, ingots, blooms, slabs, billets, sheet bars, tinplate bars and equivalent primary forms	—
(13) Iron and steel products, namely, plates, sheets, strip universals uncoated; joists, girders, angles, sections and bars cut to size but not further worked, excluding concrete reinforcing rounds; castings and forgings not further worked	—
(14) Jute, raw .. ..	—
(15) Lead, unwrought and simply worked ..	—
(16) Leather and textile materials .. ..	Shoes
(17) Phenol formaldehyde, gelatin pearl glue and extruder powder used with such substances ..	—
(18) Pigments, colouring materials and dye-stuffs, but not including washing blue, prepared paints and distempers.. ..	—
(19) Plastic materials, synthetic, in powder, liquid, solid (but not sheet) or granule form .. ..	—
(20) Splints and skillets ..	Matches and match boxes
(21) Tinplate of iron and steel, not exceeding .016 inch gauge unworked ..	—
(22) Tyre cord, of textile materials other than cotton .. ..	Tyres
(23) Wire rod; galvanised wire .. ..	Nails; wire products
(24) Wire, steel and multi-strand .. ..	Tyres
(25) Zinc ingots .. ..	Galvanised products."

(b) by the insertion of a new item as follows :—

“6A. Articles, the following, where the Board is satisfied that they are imported *solely* for the following purposes :—

<i>Article</i>	<i>Purpose</i>
<p>Parts, identifiable as such, of machinery, apparatus and appliances, but not including machines mainly for domestic use, tanks of iron or steel, toilet machines, weighing machines, vehicles, or internal combustion engines suitable for driving vehicles.</p>	<p>(1) Intended for scientific machinery, apparatus or appliances, and for scientific purposes or research, or for education in science. (2) Intended for specialised hospital or surgical equipment, and for use in connection with medical or surgical treatment.”</p>
<p>(c) by the deletion of the expression “means unrefined gold and silver in amalgam or lumps and bars and refined gold and silver in bars” in item 8 and the substitution thereof of the expression “means refined gold or silver in lumps, bars or amalgam ; refined gold or silver in bars”.</p>	
<p>(d) by the deletion of the expression “the Nigerian Railway Corporation” in item 46 and the substitution thereof of the expression “the Nigerian Railway Corporation, the Nigerian Ports Authority, or a person approved in that behalf by the Minister”.</p>	

MADE at Lagos this 26th day of November, 1964.

R. C. ONYEJEPU,  
*Acting Deputy Secretary  
to the Council of Ministers*

#### EXPLANATORY NOTES

This Order has the following effects—

#### FIRST SCHEDULE—IMPORT DUTY

(a) Reduces —

- (1) from 33½ *per centum* to 10 *per centum ad valorem* the rate for professional robes of judges, law officers, magistrates and all officers of the Nigerian Civil Service who are barristers-at-law.
- (2) the rate for cement clinker from £1-15s-0d the ton or *ad valorem* 20 *per centum* to £1 the ton.

- (3) from  $33\frac{1}{3}$  per centum to 5 per centum *ad valorem* the rate for identifiable parts of certain types of machinery, apparatus, appliances and tools.
- (4) the rate for kraft paper for use by approved manufacturers from 25 per centum to 10 per centum *ad valorem*.
- (b) Restores the concessionary rate of 2*d* each for approved importations of bags and sacks made of textile materials other than jute.
- (c) Re-introduces an alternative rate—now at  $33\frac{1}{3}$  per centum—for bags and sacks made of textile materials other than jute.
- (d) Makes identifiable parts of furniture dutiable at the same rates—*ad valorem* 50 or 75 per centum—as main articles of furniture.
- (e) Restricts the alternative specific rate of 3*s*-3*d* per pound for interlock fabrics to approved manufacturers of excisable goods and prescribes 15*s* the pound for other importations.
- (f) Increases the rates for :—
- (1) other road motor vehicles including motor cycles and motorised cycles from 25 per centum to  $33\frac{1}{3}$  per centum *ad valorem*.
  - (2) caustic soda for ordinary users from £2 to £3 the hundred-weight.
- (g) Rationalises further the arrangement and, also in some cases, the wording of the items for certain goods like singlets, firearms, paint, interlock fabrics, bleached and unbleached cotton fabrics.

#### SECOND SCHEDULE—EXEMPTION FROM IMPORT DUTIES

- (a) Prescribes approved user exemptions for empty glass bottles, wire rod, galvanised wire, zinc ingots, railway requisites, identifiable parts of certain types of machinery, apparatus and appliances.
- (b) Rationalises the item for bullion and approved users.



L.N. 120 of 1964

CONSTITUTION OF MID-WESTERN NIGERIA ACT, 1964  
(1964, No. 3)

Mid-West Constituency Delimitation (Approval) Order, 1964

*Commencement : 21st January, 1964*

In exercise of the powers conferred by subparagraph 2 (a) of paragraph 2 of the Second Schedule to the Constitution of Mid-Western Nigeria and all other powers enabling me in that behalf, I hereby make the following Order—

1. This Order may be cited as the Mid-West Constituency Delimitation (Approval) Order, 1964, and shall be deemed to have come into force on the 21st of January, 1964.
2. The division of the Mid-Western Region into sixty-five constituencies as prescribed by the Electoral Commission of the Federation in its Report dated the 4th of January, 1964, is hereby approved.

MADE at Lagos this 11th day of February, 1964.

ABUBAKAR TAFAWA BALEWA,  
*Prime Minister of the Federation*

Citation  
and  
Commencement.

Approval  
Division  
into  
Constituencies.



4. If Company, is the Company registered under the Companies Act ?

.....  
If so, attach a certified true copy of the certificate of registration and give details of its capital structure and paid-up capital.

5. Name under which it is proposed to establish and operate the casino

.....  
6. The address or addresses of the premises at which the casino is to be operated.

(1) .....

(2) .....

7. Date of issue and expiry of any previous licence and the addresses of premises approved in such licence :—

(1) .....

(2) .....

8. Period for which a licence is desired.....

I/We,.....  
declare that the information given by me/us above is true and correct in every particular.

GIVEN under my/our hand(s) this..... day of..... 19.....

.....  
.....  
.....

*\* Signature(s) of Applicant(s)*

.....  
\* If a Company, the application should be signed by the Secretary and the Managing Director or Manager.

FORM "B"

CASINO LICENCE

Regulations (5)

No. ....

(Name).....

(Address).....

is hereby licensed to establish and operate a Casino at the following premises only :—

(a) .....

(b) .....

(c) .....

(d) .....

(e) .....

2. The games approved under this licence are as follows :—

- (a) .....
- (b) .....
- (c) .....
- (d) .....

3. This Licence is subject to the conditions prescribed in Regulation 7 of the Casino (Licensing) Regulations, 1964.

4. This licence expires on the.....19.....

Fee paid : £.....

Date.....

Minister of Internal Affairs

MADE at Lagos this 25th day of November, 1964.

ALHAJI SHEHU SHAGARI,  
Minister of Internal Affairs

L.N. 133 of 1964

ELECTORAL ACT, 1962 (1962 No. 31)

Electoral Regulations, 1964

Commencement : 1st August, 1964

In exercise of the powers conferred by section 164 of the Electoral Act, 1962, and after consultation with the Electoral Commission of the Federation, I hereby make the following regulations :—

1.—(1) These regulations may be cited as the Electoral Regulations, 1964, and shall apply throughout the Federation.

(2) These regulations shall be deemed to have come into effect on the 1st day of August, 1964.

2. The registration officer in charge of each constituency shall divide the constituency into registration areas and may subdivide each registration area into registration units; and in any such event he shall publish in such manner as circumstances may require in the constituency, a notice specifying the limits of the registration areas and the addresses of the registration offices.

3. When in use for voting, ballot boxes shall be at least six inches away from each other and shall be screened from observation by all persons other than the voter casting his vote.

4. Ballot boxes shall be placed so that they are clearly visible to electors entering the compartment and be fixed in such position so that they cannot be moved during the hours of voting. As nearly as possible they shall be placed equidistant from the entrance to the compartment.

MADE at Lagos this 26th day of November, 1964.

ALHAJI SHEHU SHAGARI,  
Minister of Internal Affairs

Citation,  
application  
and  
commence-  
ment.

Division into  
registration  
areas, etc.

Position of  
ballot boxes.

Visibility of  
ballot boxes.

L.N. 134 of 1964

## PROCLAMATION

*(Under the Constitution of the Federation)*

## Parliament (Dissolution) Proclamation, 1964



NNAMDI AZIKIWE,  
*President*

By His Excellency Doctor NNAMDI AZIKIWE, President  
and Commander-in-Chief of the Federal Republic  
of Nigeria.

In exercise of the powers conferred upon me by subsection (1) of section sixty-eight of the Constitution of the Federation, and of all other powers enabling me in that behalf, I, NNAMDI AZIKIWE, President as aforesaid, do hereby proclaim that Parliament shall stand dissolved on the 8th day of December, 1964.

GIVEN under my hand and the Public Seal of the Federal Republic of Nigeria at the State House, the Seventh day of December, one thousand, nine hundred and sixty-four.

L.N. 135 of 1964

CASINO LICENSING ACT, 1964  
(1964 No. VIII)

## Appointed Day Notice

In exercise of the powers conferred on me by subsection (2) of section 8 of the Casino Licensing Act, 1964, I hereby appoint the First day of December, 1964 as the day on which the above Act shall come into force.

DATED at Lagos this 1st day of December, 1964.

ALHAJI SHEHU SHAGARI,  
*Federal Minister of Internal Affairs*



L.N. 136 of 1964

MINERALS ACT (CHAPTER 121)

Prospecting (Areas and Minerals) Prohibition  
(Amendment) (No. 9) Declaration, 1964

Commencement : 10th December, 1964

In exercise of the powers conferred by section 8 of the Minerals Act (Chapter 121) and of all the other powers enabling me in that behalf, I hereby make the following declaration—

1. This Declaration may be cited as the Prospecting (Areas and Minerals) Prohibition (Amendment) (No. 3) Declaration 1964 and shall apply throughout the Federation.

Citation and application.

2. Immediately after paragraph 44 of the Prospecting (Areas and Minerals) Prohibition Declaration 1946, there shall be inserted the following new paragraph :—

Amendment of Public Notice 22 of 1946 (Vol. IX P.1443 1958 Laws).

“45. The following area is hereby declared to be closed to prospecting for all minerals :—

All that parcel of land known as MRA. 39 (part of late ML.536, and the whole of late ML.133), in the Jos Division of Plateau Province, containing an area of approximately 265.8 acres, the boundaries of which are described as follows : that is to say :—

Starting at a concrete pillar, marked LB. MRA.39, the Colony Co-ordinates of which are :—

N2, 173, 927 ; E2, 333, 672.

the boundaries run in straight lines, the bearings and lengths of which are as follows :

From	Bearing	Length	To
LM MRA.39	270° 40'	3535.1 feet	CB1 MRA.39
CB1 MRA.39	180° 43'	416.2 feet	CB2 MRA.39
CB2 MRA.39	93° 41'	853.1 feet	CB3 MRA.39
CB3 MRA.39	156° 01'	1703.5 feet	CB4 MRA.39
CB4 MRA.39	185° 00'	181.2 feet	CB5 MRA. 39
CB5 MRA.39	268° 26'	512.3 feet	CB6 MRA.39
CB6 MRA.39	359° 18'	487.8 feet	CB7 MRA.39
CB7 MRA.39	270, 36'	1030.1 feet	CB8 MRA.39
CB8 MRA.39	180° 51'	489.5 feet	CB9 MRA.39
CB9 MRA.39	270° 28'	972.4 feet	CB10 MRA.39
CB10 MRA.39	180° 14'	1209.4 feet	CB11 MRA.39
CB11 MRA.39	90° 14'	2570.1 feet	CB12a MRA.39
CB12a MRA.39	89° 59'	1975.4 feet	CB12 MRA.39
CB12 MRA.39	359° 59'	1779.9 feet	CB13 MRA.39
CB13 MRA.39	00° 00'	1603.6 feet	LM MRA.39

(the starting point).

The Prior rights of WL.943 are to be preserved.

All bearings and lengths are approximate and all bearing are referred to Colony North.

MADE at Lagos this 29th day of September, 1964.

MIMP1160/Vol. 3

MAITAMA SULE,  
Minister of Mines and Power

L.N. 137 of 1964

**LOCAL LOANS (REGISTERED STOCKS AND SECURITIES)  
ACT (CAP. 111)**

**Local Loan (Federal Republic of Nigeria First Development  
Loan, 1988) Directions, 1963 (Amendment) Regulations 1964**

*Commencement : 21st November, 1963*

In exercise of the powers conferred upon me by subsection (1) of Section 47 of the Local Loans (Registered Stocks and Securities) Act and of all other powers enabling me in that behalf I hereby make the following Regulations :—

1.—(1) These Regulations may be cited as the Local Loans (Federal Republic of Nigeria First Development Loan, 1988) Directions 1963 (Amendment) Regulations 1964, and shall apply throughout the Federation.

(2) These Regulations shall be deemed to have come into effect on the 21st day of November, 1963.

2. The Local Loans (Federal Republic of Nigeria First Development Loan, 1988) Directions 1963 are amended by the substitution for section 6 thereof of the following :—

“6. The half-yearly contributions out of the general revenue and assets of the Federation to a Sinking Fund established for the purpose of redeeming this loan shall be at the rate of 0.884 per centum of the principal sum raised. The first such payment shall be made on 15th July, 1964.”

MADE at Lagos this 17th day of November, 1964.

F. S. OKOTIE-EBOH,  
Federal Minister of Finance

**EXPLANATORY NOTE**

These Regulations amend the Local Loan (Federal Republic of Nigeria First Development Loan, 1988) Directions 1963 in order to ensure that at least 75 per cent of the principal sum would accumulate at maturity.

Mi.2

Supplement to Official Gazette Extraordinary No. 102, Vol. 51, 15th December,  
1964—Part B

L.N. 138 of 1964

ANTIQUITIES ACT  
(CHAPTER 12)

**Antiquities (Monuments) Declaration Notice, 1964**

*Commencement : 15th December, 1964*

WHEREAS the Antiquities Commission, in accordance with subsection (4) of section 14 of the Antiquities Act, has submitted an application for the declaration of the Antiquities set forth in the Schedule hereto as monuments :

AND WHEREAS the application has been considered by the President :

Now in exercise of the powers conferred by subsection (5) of section 14 of the Antiquities Act, and of all other powers enabling him in that behalf the President has given the following notice :

1. This notice may be cited as the Antiquities (Monuments) Declaration Notice, 1964.

Citation.

2. The antiquities set forth in the Schedule to this notice are hereby declared to be monuments.

Declaration  
of Monu-  
ment.

SCHEDULE

- (i) Habe Mosque at Maigana, Zaria Province.
- (ii) The Old Iga Building in Iga Idunganran.
- (iii) Ate Ogu Tumulus near the Palace of the Ata of Idah, Kabba Province, Northern Nigeria.
- (iv) Tsoebe's Tomb at Gwangwade, Northern Nigeria.
- (v) Oshun Shrine at Afin Ataoja, Oshogbo, Western Nigeria.
- (vi) Sungbo's Shrine in Ijebu-Ode, Western Nigeria.
- (vii) Chief Nwokolo's House at Ukehe, Eastern Nigeria.
- (viii) Rock Shelters called Dutsen Murufu and Dutsen Sango at Birininkudu, Kano Province.
- (ix) Habe Mosque at Bebeji, Kano Province.

MADE this 15th day of December, 1964.

R. C. ONYEJEPU,  
Acting Deputy Secretary to the  
Council of Ministers



## L.N. 139 of 1964

NIGERIAN RESEARCH INSTITUTES ACT, 1964  
(1964, No. 33)**The Nigerian Research Institutes Act (Restricted Commencement)  
Order 1964**

In exercise of the powers conferred by subsection (2) of section 9 of the Nigerian Research Institute Act 1964, I hereby make the following Order :—

1. The Nigerian Research Institute Act, 1964 except insofar as it relates to the Rubber Research Institute of Nigeria, shall come into force on the 1st day of December, 1964. Commence-  
ment.
2. This Order may be cited as the Nigerian Research Institute Act (Restricted Commencement) Order 1964. Citation.

MADE in Lagos this 20th day of November, 1964.

WAZIRI IBRAHIM,  
*Federal Minister of Economic Development*

## L.N. 140 of 1964

CUSTOMS AND EXCISE MANAGEMENT ACT, 1958  
(No. 55 of 1958)**Drawback (Customs) (Amendment) (No. 2) Regulations 1964**

*Commencement : 9th March, 1964*

In exercise of the powers conferred by subsection (1) of section 122 of the Customs and Excise Management Act, 1958 and of all other powers enabling him in that behalf, the President hereby makes the following regulations :

- 1.—(1) These regulations may be cited as Drawback (Customs) (Amendment) (No. 2) Regulations, 1964, and shall apply throughout the Federation. Citation,  
application  
and com-  
mencement.
- (2) These regulations shall be deemed to have come into effect on the 9th day of March, 1964.
2. The Schedule to the Drawback (Customs) Regulations 1959 as substituted by the Drawback (Customs) (Amendment) Regulations, 1964, is hereby amended by :— Amendment  
to Schedule  
to L.N. 70  
of 1959.
  - (a) the deletion of item (2); and
  - (b) the renumbering of item (3) as item (2).

MADE at Lagos this 4th day of December, 1964.

R. C. ONYEJEPU,  
*Acting Deputy Secretary to the  
Council of Ministers*

## EXPLANATORY NOTE

The purpose of this regulation is to remove the anomaly resulting from the deletion of "Stationery" from exemption item 65 of the 2nd Schedule to the Customs Tariff Act, No. 60 of 1958.

L.N. 141 of 1964

MERCHANT SHIPPING ACT 1962  
(1962, No. 30)

Receiver of Wreck and Assistant Receivers of Wreck  
(Appointment) Notice 1964

Commencement : 17th December, 1964

In exercise of the powers conferred by subsection (1) of section 302 of the Merchant Shipping Act, 1962, I hereby appoint the persons holding the offices specified in the first column of the Schedule hereunder to the respective posts specified in the Second Column for the areas specified in the Third Column as set opposite the designated office.

2. Government Notice No. 1599 of 1959 is hereby cancelled.

SCHEDULE

<i>Office</i>	<i>Post to which Appointed</i>	<i>Area</i>
Government Inspector of Shipping, Ministry of Transport, Lagos	Receiver of Wreck	The Coast and tidal waters in Nigeria
Principal Nautical Surveyor, Ministry of Transport, Lagos	Assistant Receiver of Wreck	(a) The Nigerian coast and all waters from the border with Dahomey up to but not including the Benin River Entrance.
		(b) The Inland Waters within the Federal Territory of Lagos and the Provinces of Abeokuta, Ijebu and Ondo.
Harbour Master, Delta Ports, Nigerian Ports Authority, Sapele	Assistant Receiver of Wreck	The Nigerian Coast and the Ports and port approaches from and including the Benin River Entrance up to but not including the Nun River Entrance.
The Divisional Marine Officer, Inland Waterways Department, Warri	Assistant Receiver of Wreck	The inland waters within the Benin and Rivers Provinces West of but not including the Nun River and the River Niger itself up to but excluding ports and port approaches.
Harbour Master, Nigerian Ports Authority, Port Harcourt	Assistant Receiver of Wreck	The Nigerian coast and the ports and port approaches from and including the Nun River Entrance up to but not including the Qua Iboe River Entrance.

<i>Office</i>	<i>Post to which Appointed</i>	<i>Area</i>
Divisional Marine Officer, Inland Waterways Dept., Port Harcourt	Assistant Receiver of Wreck	The inland waters within the Owerri Province East of and including the Nun River, and the Calabar Province West of but not including the Qua Iboe River, but excluding ports and port approaches.
Harbour Master, Nigerian Ports Authority, Calabar	Assistant Receiver of Wreck	(a) The Nigerian coast from and including the Qua Iboe River Entrance up to the territorial waters of the Cameroun Republic in the mouth of the Cross River.  (b) The inland waters of Calabar Province East of and including the Qua Iboe River, the Province of Ogoja and the Cross River and its affluents West of the Cameroun Republic and the Cameroun Boundary.
Divisional Marine Officer, Inland Waterways Dept., Lokoja	Assistant Receiver of Wreck	The River Niger and its affluents North of but not including Idah.
Local Marine Officer, Inland Waterways Department, Onitsha.	Assistant Receiver of Wreck	The River Niger and its affluents from but not including Aboh up to and including Idah.

MADE this 17th day of December, 1964.

R. A. NJOKU,  
*Minister of Transport*

#### EXPLANATORY NOTE

This notice provides for the appointment of Receiver of Wreck and Assistant Receivers of Wreck.

T 3505/S. 3



L.N. 142 of 1964

PORTS ACT 1958 TO 1963

**Nigerian Ports Authority Petroleum Wharf (Apapa)  
(Amendment) By-Laws, 1964**

*Commencement : 24th December, 1964*

In exercise of the powers conferred by section 44 of the Ports Act and of all other powers enabling it in that behalf, the Nigerian Ports Authority hereby make the following by-laws—

1. These by-laws may be cited as the Nigerian Ports Authority Petroleum Wharf (Apapa) (Amendment) By-laws, 1964. Short title.

2. The Nigerian Ports Authority Petroleum Wharf (Apapa) By-laws, 1959, are hereby amended as follows :— Amendment  
to L.N. 266  
of 1959.

(a) in By-law 3, between the definitions of "Harbour Master" and "Oil", insert the following new definition—

"Liquefied Petroleum Gas" means light hydrocarbon material, gaseous at atmospheric temperature and pressure, held in the liquid state by pressure to facilitate storage, transport and handling".

(b) after By-law 20, insert the following heading and new By-laws 21-33.

**"LIQUEFIED PETROLEUM GAS**

21. Before commencing to load or discharge a liquid petroleum gas cargo, the boiler and galley fires shall be extinguished and remain so until loading or discharging operations have been completed.

22. The shore hoses shall be tested before each operation to a pressure of 3 kilograms per square centimetre in excess of the maximum anticipated pressure during the handling operations.

23. Each shore hose shall be fitted with shut-off valves to ensure that the possibility of an escape of liquefied petroleum gas is kept to the minimum when the hoses are disconnected.

24. No person shall wear metal studded footwear on the vessel or on the jetty-head.

25. Fire hoses shall be rigged fore and aft ready for immediate use to warn craft not to approach during loading or discharging operations.

26. The master shall ensure that an officer is present on deck at all times during loading or discharging operations. It shall be the master's duty to ensure that the measures provided in By-laws 21 to 33 are carried out.

27. Appropriate steps should be taken to stop any leakages and should be reported to the Chief Fire Officer.

28. During the handling operations, all doors leading from the deck to the accommodation or engine room shall be kept closed to prevent the accumulation of vapour in these spaces.

29. The master shall ensure that all hose connections are checked and that the couplings are connected by bolts sufficiently long to ensure that the nuts are well held and the bolts tightened evenly.

30. During the handling operations, no person shall have access to the ship who is not directly connected with the operations.

31. During the handling operations, continuous gas testing shall be carried out in the pump house. In the event of a concentration exceeding 40 per cent of the lower explosive limit being detected, pumping operations must cease and all valves on the gas bottles and cross-overs must be closed at once until the leak has been traced and stopped.

32. No Loading or discharging shall take place unless excess flow valves are fitted in suitable positions at the outlet manifold to ensure the automatic shut-off of liquefied petroleum gas in the event of a hose fracture. In the event of the closure of these valves the liquefied petroleum gas system must be isolated until the cause of the closure has been investigated.

33. All pipes, joints, flexible hoses and other appliances must be adequately and continuously earthed and the vessel itself must be electrically bounded and earthed".

(c) renumber existing By-law 21 to read By-law 34.

The Common Seal of the Nigerian Ports Authority was hereunto affixed by order of the said Authority the 23rd day of July, One thousand nine hundred and sixty-four, in the presence of—

H. A. EJUEYITCHIE,  
*Temporary Chairman*

BAYO KEHINDE,  
*Secretary to the Authority*

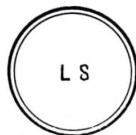

APPROVED this 26th day of September, 1964.

R. A. NJOKU,  
*Minister of Transport*

#### EXPLANATORY NOTE

The amendments to the by-laws are being made in order to control the loading and discharging of liquefied petroleum gas cargo for safety reasons.

L.N. 143 of 1964

**BANKING ACT (CHAPTER 19)**  
**British and French Bank (Revocation of Licence)**  
**Order, 1964**

*Commencement : 1st December, 1964*

In exercise of the powers conferred by paragraph (b) (1) of subsection (5) of Section 3 of the Banking Act and of all other powers enabling me in that behalf I hereby make the following Order :—

1. The licence granted on the 1st day of April, 1953 to the British and French Bank to carry on banking business at their registered office at 127/129 Broad Street, Lagos is hereby revoked.

Revocation  
of licence.

2. (1) This Order may be cited as the British and French Bank (Revocation of Licence) Order, 1964 and shall apply throughout the Federation.

Citation  
and appli-  
cation

(2) This Order shall come into force on the 1st day of December, 1964.

Commence-  
ment.

MADE at Lagos this 5th day of December, 1964.

CHIEF FESTUS SAM OKOTIE-EBOH,  
*Federal Minister of Finance*

EXPLANATORY NOTE

The purpose of this Order is to put an end formally to the operation of banking business in Nigeria by the British and French Bank which has since ceased to carry on its business in Nigeria.

L.N. 144 of 1964

**THE PRISONS ACT, 1960**  
(No. 41 OF 1960)

**Notice of Consent**

WHEREAS the Governor of Mid-Western Nigeria has consented to the conferring of the functions referred to in sections 19, 20, 21, 24, 25 and 27 of the Prisons Act, 1960 on officers and authorities of Mid-Western Nigeria.

NOTICE is hereby GIVEN by me signifying such consent aforesaid and accordingly sections 19, 20, 21, 24, 25 and 27 of the said Act shall come into operation (to the extent that those sections are not in operation) in Mid-Western Nigeria on the date of publication of this notice in the *Gazette*.

DATED at Lagos this 20th day of November, 1964.

ALHAJI SHEHU SHAGARI,  
*Federal Minister of Internal Affairs*

L.N. 145 of 1964

MERCHANT SHIPPING ACT, 1962  
(1962, No. 30)

**Merchant Shipping (Certificates of Competency) (Engine Room)  
(Amendment) Regulations 1964**

*Commencement : 23rd November, 1964*

In exercise of the powers conferred by section 427 of the Merchant Shipping Act, 1962 and of all other powers enabling me in that behalf I hereby make the following Regulations :—

1. These Regulations may be cited as the Merchant Shipping (Certificates of Competency) (Engine Room) (Amendment) Regulations 1964 and shall apply to examinations for certificates of competency which are required to be held by the engineer officers and the ratings of merchant ships under the Merchant Shipping (Manning) Regulations, 1963.

2. The Certificates of Competency (Engine Room) Regulations 1963 are hereby amended by the addition to the Seventh Schedule thereto of the following :—

“Nigeria Police Engineering Workshops, Lagos”.

MADE at Lagos this 24th day of December, 1964.

R. A. NJOKU,  
*Federal Minister of Transport*

EXPLANATORY NOTE

These Regulations add the Nigeria Police Engineering Workshop, Lagos, to the list of approved Workshops.

---

L.N. 146 of 1964

FIREARMS ACT  
(CAP. 69)

**Firearms (Amendment) Regulations, 1964**

*Commencement : 24th December, 1964*

In exercise of the powers conferred by Section 33 of the Firearms Act and of other powers enabling me in that behalf I hereby make the following regulations—

1. These regulations may be cited as the Firearms (Amendment) Regulations, 1964.

2. Regulation 12 of the Firearms Regulations 1959, is amended by renumbering it as paragraph (1) and the addition of the following paragraphs.

“(2) Any registration in the register of firearms dealers shall remain in operation until the 31st December, of the year in which it was affected.

(3) Any such registration may be renewed at the discretion of the authorised Police Officer on payment of the prescribed fee, if any.”

MADE at Lagos this 23rd day of December, 1964.

ABUBAKAR TAFAWA BALEWA,  
*Prime Minister of the Federation*

EXPLANATORY NOTE

The purpose of this amendment is to make provision for annual renewal of registration of firearms dealers.

Citation  
and Com-  
mencement

Amend-  
ment to  
L.N. 135  
of 1963.

Citation.

Amendment  
of Regula-  
tion 12  
Firearms  
Regulations  
1959 L.N. 28  
of 1959.

L.N. 147 of 1964

PUBLIC ORDER (LAGOS) ACT, CAP. 169

The Public Order (Lagos) (No. 3) Order, 1964

Commencement : 30th December, 1964

WHEREAS I am of the opinion that, by reason of particular circumstances existing in Lagos, the powers conferred upon the Minister charged with responsibility for Lagos municipal affairs by subsection (1) of section five of the Public Order (Lagos) Act will not be sufficient to prevent serious public disorder being occasioned by the holding of public meetings or public processions in Lagos.

NOW THEREFORE, in exercise of the powers conferred on me by subsection (2) of section five of the Public Order (Lagos) Act, I hereby make the following order :—

1.—(1) No public meeting or public procession (other than those excepted from the provisions of this sub-paragraph by the following sub-paragraph) shall be held in Lagos during the period of two months beginning with the time when this order comes into force.

Prohibition of public meetings and public processions in Lagos.

(2) There shall be excepted from the provisions of the foregoing sub-paragraph any public meeting or public procession specified in a notice which is—

(a) signed by me or by any officer of the Ministry of Lagos Affairs not below the rank of Senior Assistant Secretary ; and

(b) served on an officer of the Nigeria Police not below the rank of Chief Superintendent.

2. This order may be cited as the Public Order (Lagos) (No. 3) Order, 1964, and shall come into force at eight o'clock on the night of the thirtieth day of December, Nineteen hundred and sixty-four.

Citation and comment.

MADE at Lagos, this 30th day of December, 1964.

MUSA YAR'ADUA,  
Minister of Lagos Affairs



L.N. 148 of 1964

## FIREARMS ACT (CHAPTER 69)

## Firearms Prohibition (Mid-Western Nigeria) Order, 1964

*Commencement : 31st December, 1964*

In exercise of the powers conferred upon me by section 36 of the Firearms Act and of all other powers enabling me in that behalf I hereby make the following Order :—

1. This Order may be cited as the Firearms Prohibition (Mid-Western Nigeria) Order, 1964, and shall apply only to Mid-Western Nigeria. Citation and application.
2. The possession of or dealing in any firearms or ammunition in the Irrua-Ewa District Council area and in the Ewohimi-Ewatto-Ewossa District Council area in the Ishan Division of Benin Province in Mid-Western Nigeria, is hereby prohibited for a period of three months from the date of publication of this Order. Prohibition.
3. All firearms and ammunition in possession of any person within the area specified in the foregoing paragraph 2 of this Order shall be surrendered forthwith to the Divisional Police Officer, Ishan Division, Ubiaja. Surrender.

MADE at Lagos this 28th day of December, 1964.

ABUBAKAR TAFAWA BALEWA,  
*Prime Minister of the Federation*

NP/91/S. 1/Vol. III



Supplement to Official Gazette Extraordinary No. 108, Vol. 51, 31st December,  
1964—Part B

L.N. 149 of 1964

CUSTOMS TARIFF ACT, 1958  
(No. 60 of 1958)

Customs Tariff (Duties and Exemptions) (No. 9) Order, 1964

*Commencement : 5th January, 1965*

In exercise of the powers conferred by subsection (1) of section 6 of the Customs Tariff Act, 1958, the President has made the following Order—

1. This Order may be cited as the Customs Tariff (Duties and Exemptions) (No. 9) Order, 1964, and shall apply throughout the Federation.

Short title  
and  
application.

2. The First Schedule to the Customs Tariff Act, 1958 (which relates to the import duties of Customs) as the same was replaced by the Customs Tariff (Duties and Exemptions) (No. 7) Order, 1964, is amended by the deletion of the expression "the pound 0 0 2" in sub-item 17 of item 51 and the substitution therefor of the expression "the pound 0 0 3½d".

Amendment  
of First  
Schedule  
to No. 60  
of 1958.  
L.N. 91  
1964.

MADE at Lagos this 30th day of December, 1964.

R. C. ONYEJEFU,  
*Acting Deputy Secretary to the  
Council of Ministers*

EXPLANATORY NOTE

This Order increases the duty on sugar from 2d the pound to 3½d the pound.



L.N. 123 of 1964

## IMMIGRATION ACT

(1963, No. 6)

**The Ekwete Amusa Deportation Order, 1964**

WHEREAS on the 22nd day of February, 1964, EKWETE AMUSA was convicted of an offence under section 222 of the Criminal Code at the Magistrates' Court, Lagos.

AND WHEREAS the said Court in exercise of the powers conferred by section 404 of the Criminal Procedure Act, recommended that the said Ekwete Amusa be deported from Nigeria.

AND WHEREAS I, ALHAJI SHEHU SHAGARI, Federal Minister of Internal Affairs, after considering the recommendation aforesaid, am satisfied that it is in the public interest that a deportation order be made.

NOW THEREFORE, in exercise of the powers conferred upon me by subsection 1 of section 20 of the Immigration Act, 1963, it is hereby ordered that the said EKWETE AMUSA upon the expiration of any sentence of imprisonment which he is now serving, and at the first available opportunity shall leave Nigeria and thereafter remain out of Nigeria.

MADE at Lagos this 21st day of October, 1964.

M.I.A./6181

SHEHU SHAGARI,  
*Federal Minister of Internal Affairs*

L.N. 124 of 1964

## INCOME TAX ACT (CAP. 85)

**Authorised Deductions (Nigerian Ports Authority) Rules, 1964***Commencement : 1st April, 1959*

In exercise of the powers conferred by subsection (1) of section five, paragraph (h) of subsection (1) and subsection (2) of section ten of the Income Tax Act, and of all other powers enabling me in that behalf, I hereby make the following rules :—

1. For the purpose of ascertaining the income or loss of the Authority, under the Income Tax Act, of any period between 1st April, 1959 and 31st March, 1961, from the port business of the Authority, there shall be deducted—

Authorised  
Deductions.

(a) any interest paid by the Authority during such period to the Government in respect of the 'Port A Stock' and the 'Port B Stock', being the stocks which may be issued by the Authority under an Agreement dated 1st December, 1959, made between the Government and the Authority which Agreement relates, inter alia, to the terms upon which certain assets formerly owned by the Government vested in the Authority upon its vesting days ;

(b) Any interest paid during such period in respect of the advance of £770,000 referred to in clause three of the said Agreement or in respect of so much of that advance as may be outstanding from time to time ;

(c) an amount for depreciation in the value of such assets of the Authority as are specified in the schedule to that Agreement which amount shall be determined in accordance with the provisions of paragraph (b) of subclause (1) of clause nine of that Agreement.

Interpretation.

2. In these rules—

“the Authority” means the Nigerian Ports Authority ;

“Government” means the Government of the Federal Republic of Nigeria.

Citation and Commencement.

3.—(1) These rules may be cited as the Authorised Deductions (Nigerian Ports Authority) Rules, 1964, and shall be deemed to have come into operation on the 1st day of April, 1959.

Application.

(2) These rules shall be of Federal application.

MADE at Lagos this 29th day of October, 1964.

F. S. OKOTIE-EBOH,  
Federal Minister of Finance

1484/C

EXPLANATORY NOTE

These rules make provision for the income tax allowances authorised to be made in respect of certain interest payments and capital depreciation under subclause (1) of clause nine of an Agreement dated 1st December, 1959, made between the Federal Government and the Nigerian Ports Authority. The Rules have application only with respect to tax chargeable under the Income Tax Act, (Cap. 85).

---

L.N. 125 of 1964

COMPANIES INCOME TAX ACT, 1961  
(1961, No. 22)

Authorised Deductions (Nigerian Ports Authority)  
(No. 2) Rules, 1964

Commencement : 1st April, 1961

In exercise of the powers conferred by paragraph (h) of section twenty-seven of the Companies Income Tax Act, 1961, and of all other powers enabling me in that behalf, I hereby make the following rules :—

Authorised Deductions.

1. For the purpose of ascertaining the income or loss of the Nigerian Ports Authority, under the Companies Income Tax Act, 1961, of any period (being the appropriate period for computation of such income for a year of assessment) from the port business of the Authority, there shall be deducted—

(a) any interest paid by the Authority during such period to the Government in respect of the ‘Port A Stock’ and the ‘Port B Stock’, being the stocks which may be issued by the Authority under an Agreement dated 1st December, 1959, made between the Government and the Authority which Agreement relates, *inter alia*, to the terms upon which certain assets formerly owned by the Government vested in the Authority upon its vesting day ;

(b) any interest paid during such period in respect of the advance of £770,000 referred to in clause three of the said Agreement or in respect of so much of that advance as may be outstanding from time to time ;

(c) an amount for depreciation in the value of such assets of the Authority as are specified in the schedule to that Agreement which amount shall be determined in accordance with the provisions of paragraph (b) of subclause (1) of clause nine of that Agreement.

2. In these rules—

“the Authority” means the Nigerian Ports Authority ;

“Government” means the Government of the Federal Republic of Nigeria.

3.—(1) These rules may be cited as the Authorised Deductions (Nigerian Ports Authority) (No. 2) Rules, 1964, and shall be deemed to have come into operation on the 1st day of April, 1961.

(2) These rules shall be of Federal application.

MADE at Lagos this 29th day of October, 1964.

Interpre-  
tation.

Citation  
and  
Commence-  
ment.

Application.

1484/C

F. S. OKOTIE-BOH,  
*Federal Minister of Finance*

#### EXPLANATORY NOTE

These rules make provision for the income tax allowances authorised to be made in respect of certain interest payments and capital depreciation under subclause (1) of clause nine of an Agreement dated 1st December, 1959, made between the Federal Government and the Nigerian Ports Authority. The rules have application only with respect to tax chargeable under the Companies Income Tax Act, 1961.

1917  
1918  
1919

1920  
1921  
1922

1923  
1924  
1925  
1926  
1927  
1928  
1929  
1930

CUMULATIVE INDEX TO SUBSIDIARY LEGISLATION  
FROM JANUARY TO JUNE 1964

Title	No. of Legal Notice	Page
<b>AGRICULTURAL (CONTROL OF IMPORTATION) ACT, 1959 (No. 28 of 1959)</b>		
Appointed Day Notice, 1964 .. .. .	48	B87
Plants (Control of Importation) Regulations, 1964 .. .. .	50	B89
<b>AIR FORCE ACT, 1964 (1964, No. II)</b>		
Appointed Day Order .. .. .	49	B88
<b>ANTIQUITIES ACT (CHAPTER 12)</b>		
Antiquities (Monuments) Declaration Notice, 1964 .. .. .	59	B110
<b>BILL OF EXCHANGE ACT, 1964 (1964, No. 20)</b>		
Bill of Exchange Act (Commencement) Order, 1964 .. .. .	57	B109
<b>CINEMATOGRAPH ACT, 1963</b>		
Cinematograph (Film Censorship) Regulations, 1964 .. .. .	36	B64
<b>COMPANIES INCOME TAX ACT, 1961</b>		
Companies Income Tax (Exemption) (Interconsulting Limited) Order, 1964	11	B19
Companies Income Tax (Exemption) (Kreditanstalt Fier Wiederaufbau Frankfurt am main) Order, 1964	33	B61
Companies Income Tax (Authorised Deductions) (Nigerian Industrial Development Bank) Rules, 1964 .. .. .	58	B109
<b>CONSTITUTION OF MID-WESTERN NIGERIA</b>		
Constitution of Mid-Western Nigeria (Commencement) Order, 1964	5	B7
The Constitution of Mid-Western Nigeria Act (Commencement) Order, 1964 .. .. .	7	B11
<b>CRIMINAL CODE ACT (CHAPTER 42)</b>		
Criminal Code (Prohibited Importations) Order, 1964 .. .. .	21	B31
<b>CUSTOMS AND EXCISE MANAGEMENT ACT, 1958</b>		
Drawback (Customs) (Amendment) Regulations, 1964	8	B13
Open General Export Licence (Goods and Produce of Nigeria Origin) No. 2 of 1960 (Amendment) 1964 .. .. .	18	B27
Open General Import Licence (All Countries) (No. 1) of 1964 .. .. .	44	B79
Open General Import Licence (Netherlands) (No. 2) of 1964 .. .. .	47	B85
Open General Import Licence (All Countries) (No. 1) of 1964 .. .. .	56	B105
<b>CUSTOMS TARIFF ACT, 1958</b>		
Custom Tariff (Duties and Exemptions) (No. 1) Order, 1964	1	B1
Custom Tariff (Duties and Exemptions) (No. 2) Order, 1964	6	B9
Custom Tariff (Duties and Exemptions) (No. 3) Order, 1964	26	B42
Custom Tariff (Duties and Exemptions) (No. 4) Order, 1964	42	B77
Custom Tariff (Duties and Exemptions) (No. 5) Order, 1964	43	B77
Custom Tariff (Duties and Exemptions) (No. 2) Order, 1964	51	B103
Custom Tariff (Duties and Exemptions) (No. 3) Order, 1964	52	B103
Custom Tariff (Duties and Exemptions) (No. 4) Order, 1964	53	B103
Custom Tariff (Duties and Exemptions) (No. 5) Order, 1964	54	B104
<b>DISEASE OF ANIMALS ACT (CHAPTER 54)</b>		
Disease of Animals (Amendment) Regulations 1964 .. .. .	13	B20
<b>EXCISE TARIFF ACT, 1958 (No. 58 of 1958)</b>		
Excise Duties (Amendment) Order, 1964 .. .. .	25	B30
Excise Duties (Amendment) Order, 1964 .. .. .	55	B104

Title	No. of Legal Notice	Page
<b>FINANCE (CONTROL AND MANAGEMENT) ACT, 1958 (No. 33 of 1958)</b>		
Public Funds of the Federation (Disbursement) (Amendment) Rules, 1964	39	B74
<b>FIRE SERVICE ACT, 1963, No. 11</b>		
Fire Service (Commencement) Order, 1964	17	B27
<b>IMMIGRATION ACT</b>		
Thomas Owusu—Deportation Order	12	B20
Philip George Watkins—Prohibited Immigrants Order, 1964	40	B74
<b>INCOME TAX (RENTS) ACT, 1963 (1963, No. 22)</b>		
Income Tax (Rents) Regulations, 1964	27	B47
Income Tax (Rents) (No. 2) Regulations, 1964	28	B53
<b>INDUSTRIAL DEVELOPMENT (INCOME TAX RELIEF) ACT (CHAPTER 87)</b>		
Industrial Development (Income Tax Relief) (Starch) Order, 1964	3	B4
Industrial Development (Income Tax Relief) (Yeast) Order, 1964	2	B3
<b>LABOUR CODE ACT (CHAPTER 91)</b>		
Labour Code (Trade Union Contributions) Order, 1964	29	B55
Labour Code (Trade Union Contributions) Order, 1964	30	B55
<b>LAGOS LOCAL GOVERNMENT ACT, 1959 (No. 18 of 1959)</b>		
Lagos General Rate Order, 1964	24	B37
Municipal Transport Board Regulations, 1964	31	B56
<b>MAGISTRATES' COURT (LAGOS) ACT (CHAPTER 113)</b>		
Magistrates' Court (Civil Procedure) (Amendment) Rules, 1964	66	B119
<b>MERCHANT SHIPPING ACT, 1962 (1962, No. 30)</b>		
Merchant Shipping (Certificate of Competency) (Engine Room) (Amendment) Regulations, 1964	14	B22
Merchant Shipping (Manning) Regulations, 1963	32	B59
Merchant Shipping (Manning) Regulations, 1963	35	B62
<b>APPOINTED DAY NOTICE</b>		
Merchant Shipping (Jurisdiction of Magistrates' Courts) Order, 1964	41	B75
Merchant Shipping (Radio and Direction-Finders) Rules, 1964	68	B125
Merchant Shipping (Crew Accommodation) Regulations, 1964	69	B197
<b>MID-WESTERN REGION (TRANSITIONAL PROVISIONS) ACT, 1962</b>		
Parliamentary Electoral Regulations (Amendment) Order, 1964	9	B15
Parliamentary Electoral Regulations (Amendment No. 2) Order, 1964	15	B25
Mid-Western Parliamentary Election (Validation) Order, 1964	16	B25
<b>MINERALS ACT (CHAPTER 121)</b>		
Delegation of Powers (Western Nigeria) Notice, 1964	19	B28
Prospecting (Areas and Minerals) Prohibition (Amendment) Declaration, 1964	34	B62
Prospecting (Areas and Minerals) Prohibition (Amendment) (No. 2) Declaration, 1964	63	B115
<b>MINISTER'S STATUTORY POWERS AND DUTIES (MISCELLANEOUS PROVISIONS) ACT, CHAPTER 122</b>		
Statutory Corporations (Guarantee of Loans) (Delegation of Power) Notice, 1964	23	B35

<i>Title</i>	<i>No. of Legal Notice</i>	<i>Page</i>
<b>MONEYLENDERS ACT (CHAPTER) 124</b>		
Commonwealth Development Corporation (Exemption) Order, 1963 ..	4	B5
Messrs Philip Hill (Nigeria) Ltd. (Exemption) Order, 1964 ..	20	B29
Nigerian Industrial Development Bank Limited (Exemption) Order, 1964 ..	64	B116
Commonwealth Development Corporation (Exemption) Order, 1964 ..	65	B117
<b>NATIONAL HONOURS ACT, 1964 (1964 No. 5)</b>		
The Honours Warrant, 1964 .. .. .	67	B120
<b>NIGERIA COLLEGE OF ARTS, SCIENCE AND TECHNOLOGY</b>		
(Transfer) Regulations, 1964 .. .. .	45	B82
<b>PORTS ACT (CHAPTER) 155)</b>		
Ports (Dues and Rates) (Amendment) Regulations, 1964 .. .. .	61	B111
Nigerian Ports Authority Dock and Premises (Amendment) Bye-Laws, 1964 ..	62	B113
<b>PRISONS ACT, 1960 (1960 No. 41)</b>		
Notice of Consent .. .. .	46	B83
<b>PUBLIC ORDER (LAGOS) ACT (CHAPTER) 169)</b>		
Public Order (Lagos) (No. 1) Order, 1964 .. .. .	10	B17
Public Order (Lagos) (No. 2) Order, 1964 .. .. .	37	B71
<b>REGISTRATION OF TITLES ACT (CHAPTER) 181)</b>		
Assistant Registrars of Titles Notice (Appointment) 1964 .. .. .	22	B33
<b>RENT RESTRICTION ACT (CHAPTER) 183)</b>		
Rent Restriction (Lagos Central Planning Scheme Area) (Premises Decontrol) Order, 1964 .. .. .	60	B111
<b>STAMP DUTIES ACT (CHAPTER) 191)</b>		
Stamp Duties (Mortgage and Marketable Security Duties) Regulations, 1964 ..	38	B73



L.N. 126 of 1964

## REGISTRATION OF TITLES ACT (CAP. 181)

## Registration of Titles (Application) Order, 1964

Commencement : 9th October, 1964

In exercise of the powers conferred by subsection 1 of section 2 of the Registration of Titles Act and of all other powers enabling me in that behalf, I hereby make the following Order—

1. This Order may be cited as the Registration of Titles (Application) Order, 1964 and shall apply to the Federal Territory only.

2. The Registration of Titles Act shall apply to the area specified in the Schedule hereto.

Citation and application.

Application of Cap. 181 to area specified in Schedule.

## SCHEDULE

All that parcel of land at Surulere, Yaba West, Ebute Metta West and Abule-Nla on the Mainland of the Federal Territory the boundaries of which are described below :

Starting at a concrete pillar marked LD6544 the co-ordinates of which are 5,885.15 feet south and 7,895.21 feet west of a concrete pillar marked LCS165P, the origin of Lagos Cadastral Surveys the boundaries run in straight lines, the bearings and lengths of which are as follows :—

From	Bearings	Lengths	To
LD6544	111° 22'	483.6 feet	LD6543
LD6543	111° 22'	660.0 feet	LD6542
LD6542	58° 48'	185.5 feet	C.P.
C.P.	75° 55'	44.9 feet	EA2268
EA2268	30° 34'	64.3 feet	EA2267
EA2267	36° 08'	264.7 feet	EA2266
EA2266	49° 01'	137.6 feet	EA2265
EA2265	28° 34'	82.2 feet	EA2264
EA2264	49° 51'	233.5 feet	EA2263
EA2263	341° 43'	209.7 feet	EA2262
EA2262	357° 51'	109.7 feet	EA2261
EA2261	29° 10'	179.8 feet	EA2260
EA2260	1° 24'	51.5 feet	KE364
KE364	75° 44'	4,092.2 feet	LCS1487S
LCS1487S	68° 47'	3,055.4 feet	LCS1477S

Thence southwards along Clifford Street to Lagos Street; thence westwards (into the Railway Compound) on a bearing of 245° 00' for a distance of 1,074 feet; thence on a bearing of 156° 15' for a distance of 346 feet; thence on a bearing of 244° 30' for a distance of 706 feet to Thomas Street; thence along Thomas Street on a bearing of 156° 00' for a distance of 348 feet to PBL 2311 on its junction with Ibadan Street West; thence along Ibadan Street West on a bearing of 244° 00' for a distance of 350 feet; thence along Babani Street on a bearing of 155° 00' for a distance of 338 feet to a concrete pillar marked PBL 3860; thence on a bearing of 164° 12' at a distance of 17.0 feet to PBL 3859 on the junction of Apapa Road with

Babani Street ; thence westwards along Apapa Road to its junction with Western Avenue ; thence westwards along Apapa Road to its junction with Abebe (Iganmu) Road level crossing. Thence along Abebe (Iganmu) Road to a concrete pillar marked LCS 552P

<i>From</i>	<i>Bearings</i>	<i>Lengths</i>	<i>To</i>
552P	269° 40'	232.2 feet	553P
553P	296° 44'	598.0 feet	544P
554P	276° 20'	252.5 feet	555P
555P	245° 18'	266.4 feet	556P
556P	263° 21'	179.9 feet	557P
557P	248° 43'	168.5 feet	558P
558P	282° 57'	188.3 feet	559P
559P	293° 05'	275.2 feet	560P
560P	268° 21'	260.2 feet	561P

Thence southwards on a bearing of 180° 00' and an approximate distance of 671.5 feet to the edge of the swamp. Thence along the edge of the swamp in a zig-zag direction to a point P61 on the Federal Territory boundary.

<i>From</i>	<i>Bearings</i>	<i>Lengths</i>	<i>To</i>
P61	0° 00'	533.7 feet	PBC3646
PBC3646	0° 00'	1,058.1 feet	PBC3645
PBC3645	0° 00'	444.1 feet	PBC3644
PBC3644	0° 00'	1,229.4 feet	PBC3643
PBC3643	0° 00'	899.7 feet	LCS465P
LCS465P	0° 00'	292.1 feet	LCS464P
LCS464P	0° 00'	340.0 feet	LCS463P
LCS463P	0° 00'	580.5 feet	LD6544 (the starting point).

MADE in Lagos this 4th day of November, 1964.

MUSA YAR'ADUA,  
*Minister of Lagos Affairs*

#### EXPLANATORY NOTE

This Order extends the application of the Registration of Titles Act to certain parts of the Lagos Mainland not already within the ambit of the Act.

L.N. 127 of 1964

## MERCHANT SHIPPING ACT

(1962, No. 30)

## The Merchant Shipping (Grain) Rules, 1964

Commencement : 12th November, 1964

In exercise of the powers conferred by subsection 3 of section 253 of the Merchant Shipping Act, 1962, and of all other powers enabling me in that behalf, I hereby make the following Rules.

1. These Rules may be cited as the Merchant Shipping (Grain) Rules, 1964, and shall apply to:—

Citation and application.

(a) ships which are loaded with grain within any port in Nigeria and go to sea therefrom; and

(b) ships which, having been loaded with grain outside Nigeria, enter any port in Nigeria so laden.

2. The precautions set out in the Schedule to these Rules are to be treated for the purposes of section 253 of the Act as necessary or reasonable precautions to prevent grain from shifting.

Precautions.

3. Where these Rules require that any particular fitting, appliance or apparatus, or type thereof, shall be fitted or carried in a ship or that any particular provision shall be made, the Government Inspector of Shipping may allow any other fitting, appliance or apparatus, or type thereof, to be fitted or carried, or any other provision to be made in that ship if he is satisfied that such other fitting, appliance or apparatus, or type thereof, or provision is at least as effective as that required by these Rules.

Fitting, appliance or apparatus.

## SCHEDULE

(Rule 2)

## DEFINITIONS

1. In this Schedule, unless the context otherwise requires, the following expressions have the meanings hereby respectively assigned to them, that is to say:—

“Bin” means a completely enclosed section of cargo space in the between decks or superstructure of the ship;

“Grain” includes wheat, maize, oats, rye, barley, rice, pulses and seeds;

“Heavy grain” means all grain other than oats, light barley, and cotton seed;

“Light barley” means barley which weighs 51.575 lb. or less per bushel of 1.2837 cu. ft.

## SHIFTING BOARDS

2. Shifting boards shall be of a minimum thickness of 2 inches of good sound timber, and fitted grain-tight. They shall be supported by uprights.

3. The maximum unsupported span to be allowed for shifting boards of various thicknesses shall be as follows :—

<i>Thickness</i>	<i>Span</i>	<i>Housing at Bulkheads</i>
2 in. planks ..	Unsupported span not to exceed 8 feet ..	3 ins.
2½ in. planks ..	Unsupported span not to exceed 11 feet ..	3 ins.
3 in. planks ..	Unsupported span not to exceed 13 feet ..	3 ins.

4. Shifting boards shall be securely housed at each bulkhead by means either of permanent angle bars, or of wood cants not less than 6 ins. in width and 3 ins. in thickness and suitably shored.

5. Where 2½ in. or 3 in. shifting boards are used, the boards may be butt-jointed in way of the uprights, and at least 4 ins. of plank shall be supported. Where 2 in. shifting boards are used the joints shall overlap by at least 9 ins. in way of the uprights.

6. Where no permanent arrangements are made for grain-tight filling between the beams, wood filling pieces of the same thickness as the shifting boards shall be fitted grain-tight between the beams, and shall be secured in place by cleats or scabs at both ends and fitted both sides. The cleats or scabs shall be at least 2 in. x 4 in. in size and shall extend the full depth of the filling piece and as much again below, and be securely spiked or bolted to the shifting boards and filling pieces.

#### UPRIGHTS

7. Wood uprights shall not be less than 10 in. in width and 2 in. in thickness.

8. Uprights shall be cleated to the tanktop or ceiling where fitted, and when the upright is not securely housed at the top the uppermost supporting shores or stays shall not be more than 18 in. down from the deck or top of the upright.

9. If a tier of closely spaced pillars which serves as a principal support to the deck over in a hold or compartment is utilised for supporting the shifting boards at the middle line and if the pillars are not reeled or staggered, additional support shall be provided by means of hook-bolts and vertical tieplates or uprights secured to the pillars. Such tieplates shall consist of plates not less than 3 in. in width and ½ in. in thickness and shall be through-bolted at intervals of not more than 3 ft.

10. The horizontal distances between the centres of uprights shall be as specified in paragraph 3 of this Schedule. Wood uprights used in association with wire stays shall not be less than 11 in. in width and 3 in. in thickness. The construction and dimensions of angle bar uprights used in association with wire stays shall conform to the specification and method set forth in sub-paragraph (a) of this paragraph or to one of the following specifications and to the method set forth in sub-paragraph (b) thereof :—

(a) Each upright shall consist of four angle bars 4 in. x 4 in. x .40 in. and steel plate 11½ in. x .50 in. riveted to form one complete structure allowing 4 in. housings on both forward and after sides. Brackets riveted to head and heel shall be fitted, each to take five ¾ in. bolts with corresponding lugs or angles on tanktop, tunnel top and hatch webs.

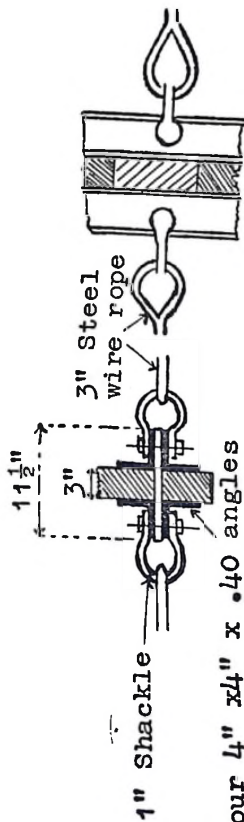

Four 4" x 4" x 1/4" angles

PLAN	ELEVATION
(b) Horizontal Dist. between centres of uprights	Sizes of angle bars
8 ft. (2" boards)	3" x 3" x 3/8 in.
8 ft. (2" boards)	3 1/2" x 3 1/2" x 3/8 in.
8 ft. (2" boards)	4 1/2" x 3 1/2" x 3/8 in.
11 ft. (2 1/2" boards)	3" x 3" x 3/8 in.
11 ft. (2 1/2" boards)	4" x 3 1/2" x 3/8 in.
11 ft. (2 1/2" boards)	6" x 3 1/2" x 3/8 in.
13 ft. (3" boards)	3" x 3" x 3/8 in.
13 ft. (3" boards)	4" x 3 1/2" x 3/8 in.
13 ft. (3" boards)	6" x 3 1/2" x 3/8 in.
Vertical Span supported by each stay	
8 feet	
11 feet	
14 feet	
8 feet	
11 feet	
14 feet	
8 feet	
11 feet	
14 feet	

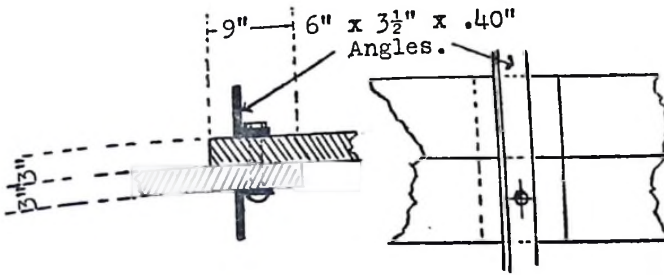

OVERLAPS OF HOLD SHIFTING BOARDS

Vertical angle bars shall be connected at head and heel to the tanktop, tunnel top, deck beams, and hatch webs by angle lugs having two 7/8 in. bolts in each angle bar upright and fastenings of equal strength to tanktop, tunnel top, deck beams, and hatch webs. The vertical angle bars shall be bolted together through the shifting boards by 7/8 in. bolts approximately 4 ft. apart.

SHORES AND STAYS

11. Wood uprights shall be supported by steel wire rope stays set up at the ship's side, or by wood shores securely heeled against the permanent structure of the ship. All wood shores shall be of good sound timber in a single piece.

SHORES

12. The vertical spacing of wood shores shall be as follows :—

Except as provided in paragraph 8 of this Schedule the uppermost shore shall not be more than 7 ft. below the top of the upright and succeeding shores shall be spaced not more than 7 ft. apart measured vertically from the uppermost shore downwards, except that a distance of eight feet shall be permitted between the lowest shore and the heel support. Shores may be heeled on the tanktop or ceilings if the heels are secured by cleats or cants and efficiently braced against the permanent structure. Shores shall not be heeled directly against the ship's side plating.

13. Subject to the provisions of paragraphs 14 and 15 of this Schedule the sizes of wood shores shall be as follows :—

Length of Shores in feet	Minimum Sizes	
	Rectangular Section	Circular Section
Not exceeding 16 .. ..	6" x 4"	5 1/2" diam.
Over 16 but not over 20 .. ..	6" x 6"	7" "
Over 20 but not over 24 .. ..	8" x 6"	7 1/2" "
Over 24 but not over 28 .. ..	8" x 6"*	8" "
Over 28 feet .. ..	8" x 6"*	8 1/2" "

\* Securely bridged at approximately mid-length.

Spliced shores shall not be used.

L.N. 11 of 1964

COMPANIES INCOME TAX ACT, 1961  
(1961, No. 22)

Companies Income Tax (Exemption) (Interconsulting Limited)  
Order, 1964

Commencement: 1st April, 1963

In exercise of the powers conferred by subsection two of section twenty-six of the Companies Income Tax Act, 1961, the Federal Minister of Finance has made the following Order—

1. This Order may be cited as the Income Tax (Exemption) (Interconsulting Limited) Order, 1963, and shall be deemed to have come into effect from the 1st of April, 1963.

Citation and  
Commencement.

2. The company known as Interconsulting Limited, whose registered office is at 43 Klaustrasse, Zurich, Republic of Switzerland (hereinafter referred to as "the company") is hereby exempted from the provision of the Companies Income Tax Act, 1961, in respect of all income earned by the Company under an Agreement dated 13th day of July, 1963, and made between the Government of the Federal Republic of Nigeria and the Company (which Agreement relates, *inter alia*, to the appointment of the Company as consulting engineers to the Government for the performance of additional and preparatory work, for the designing and planning of an integrated iron and steel mill in Nigeria).

Exemption  
of Inter-  
consulting  
Limited.

3. This exemption shall continue in force for so long as the company does not become a Nigerian Company as defined in section two of the Companies Income Tax Act, 1961.

Duration of  
Exemption.

MADE at Lagos, this 16th day of January, 1964.

F. S. OKOTIE-EBOH,  
Minister of Finance,  
Federation of Nigeria

EXPLANATORY NOTE

This Order makes provision for the income tax exemption authorised to be made in respect of the income of the Company earned under an Agreement made between the Government of the Federal Republic of Nigeria and the Company and constitutes part of that Agreement.

IMMIGRATION ACT

Thomas Owusu—Deportation Order

WHEREAS as provided under subsection (2) of section 18 of the Immigration Act, I, ALHAJI SHEHU SHAGARI, Federal Minister of Internal Affairs, am satisfied that it is in the public interest that THOMAS OWUSU *alias* EMMANUEL OWUSU *alias* ANOH ANOFI *alias* ROBERT KORANTENG should be deported from Nigeria ;

Now, THEREFORE, in exercise of the powers conferred on me by the said section 18 of the Immigration Act, it is hereby ordered that the said THOMAS OWUSU *alias* EMMANUEL OWUSU *alias* ANOH ANOFI *alias* ROBERT KORANTENG be deported from Nigeria and shall leave on the first available opportunity and remain thereafter out of Nigeria.

MADE in Lagos this 10th day of January, 1964.

SHEHU SHAGARI,  
Federal Minister of Internal Affairs

LBR 594/S. 11

L.N. 13 of 1964

DISEASES OF ANIMALS ACT (CAP. 54)

Diseases of Animals (Amendment) Regulations, 1964

Commencement : 23rd January, 1964

In exercise of the powers conferred on me by section 3 of the Diseases of Animals Act and of all other powers enabling me in that behalf, I hereby make the following regulations—

1. These regulations may be cited as the Diseases of Animals (Amendment) Regulations, 1964 and shall apply throughout the Federation.

2. The Diseases of Animals Regulations, (herein referred to as "the principal regulations") are hereby amended.

(a) by the deletion from regulation 10 of the words "except in accordance with the provisions of regulation 11" and the substitution therefor of the following—

"except under a permit granted by the Director of Veterinary Research"

(b) by the revocation of regulation 11 and the substitution therefor of the following—

"11 a permit under regulation 10 shall not be granted except on the condition that any consignment of the animals or eggs intended for hatching shall be accompanied by a certificate signed by a veterinary surgeon, in the service of, or approved by the Government of the country from which they are imported stating that the flock from which they have been obtained is free from disease. Such certificate shall be in the terms of either of the forms set out in the Schedule to these regulations."

(c) by the addition after regulation 26 of the following—

Citation and application.  
Amendment of Regulations Vol. VII p.271.

“ SCHEDULE

FDVR (1) 102

FEDERAL REPUBLIC OF NIGERIA  
 CERTIFICATE OF HEALTH FOR POULTRY  
 (OTHER THAN DAY-OLD CHICKENS)

For Purposes of Export to Nigeria

Importation Permit No. ....  
 Dated ..... Country .....

This is to certify that the .....  
 (Number) ..... (Breed) Poultry being  
 exported by .....  
 addressed to .....

originate from :

- (1) a flock kept under satisfactory hygienic conditions ;
- (2) a flock officially certified free from B.W.D. and Fowl Typhoid as determined by the agglutination test. The above mentioned birds were subjected to an agglutination test on ..... (date) with negative results :
- (3) an area free from restrictions of infectious and contagious diseases of poultry, including Newcastle Diseases, Fowl Plague and Fowl Cholera.
- (4) The birds are free from any clinical evidence of infectious or contagious disease.

To the best of my knowledge and belief the importation does not constitute any danger of introducing disease.

Signature of  
 Certifying Officer .....

Name in Block  
 Letters : .....

Official  
 designation : .....

Country : .....

Date of

Certificate : .....

FDVR (1) 103

CERTIFICATE OF HEALTH FOR DAY-OLD CHICKENS  
 For Purposes of Export to Nigeria

Importation Permit No. ....  
 Dated ..... Country .....

This is to certify that the .....  
 (Number) ..... (Breed) day-old chickens  
 being exported by .....  
 addressed to .....

originate from :

- (1) a flock kept under satisfactory hygienic conditions ;

- (2) a flock free from any clinical evidence of infectious or contagious diseases ;
- (3) a flock officially certified free from B.W.D., and Fowl Typhoid as determined by the agglutination test ;
- (4) an area free from restrictions of infectious and contagious diseases of poultry, including Newcastle Disease, Fowl Plague and Fowl Cholera.

To the best of my knowledge and belief the importation does not constitute any danger of introducing disease.

Signature of  
 Certifying Officer : .....  
 Name in Block  
 Letters : .....  
 Official  
 designation : .....  
 Country : .....  
 Date of  
 Certificate : .....”

MADE in Lagos this 23rd day of January, 1964.

WAZIRI IBRAHIM,  
 Federal Minister of Economic  
 Development

EXPLANATORY NOTE

These amendments authorise the Director of Veterinary Research to issue necessary permits for poultry brought into Nigeria in order to control such importation and prevent the introduction of animal diseases into the country.

Vet. 60/2/T

L.N. 14 of 1964

MERCHANT SHIPPING ACT, 1962  
 (1962, No. 30)

Merchant Shipping (Certificate of Competency) (Engine Room)  
 (Amendment) Regulations, 1964

Commencement : 24th October, 1963

In exercise of the powers conferred by section 427 of the Merchant Shipping Act, 1962 and of all other powers enabling me in that behalf I hereby make the following Regulations—

Amendment  
of L.N. 135  
of 1963.

1. The Certificate of Competency (Engine Room) Regulations 1963 are hereby amended by the deletion from the Seventh Schedule thereto of the name “United Africa Company Motors Ltd., Lagos” and the substitution therefor of the following—

“Niger Motors Ltd., Lagos”

2. These Regulations may be cited as the Merchant Shipping (Certificate of Competency) (Engine Room) (Amendment) Regulations 1963 and shall be deemed to have come into effect on the 24th day of October, 1963.

MADE at Lagos this 10th day of January, 1964.

R. A. NJOKU,  
*Federal Minister of Transport*

T.1926/S. 11

**B 23**  
Citation  
and  
commence-  
ment.



L.N. 15 of 1964

MID-WESTERN REGION (TRANSITIONAL PROVISIONS) ACT, 1963  
(1963, No. 19)

**Parliamentary Electoral Regulations (Amendment No. 2)  
Order, 1964**

*Commencement : 10th January, 1964*

In exercise of the powers conferred by subsection (1) of section 3 of the Mid-Western Region (Transitional Provisions) Act, 1963, and of all other powers enabling it in that behalf, the Administrative Council of Mid-Western Nigeria has made the following Order—

1. The Parliamentary Electoral Regulations, 1960 are amended by the deletion from paragraph (1) of regulation 11 thereof of the word "twenty-one" and the substitution thereof of the following—  
"seven".

Amendment  
of W.N.L.N.  
227 of 1960.

2. This Order may be cited as the Parliamentary Electoral Regulations (Amendment No. 2) Order, 1964 and shall be deemed to have come into force on the 10th day of January, 1964.

Citation  
and Com-  
mencement.

MADE this 27th day of January, 1964.

D. C. OSADEBAY,  
*Administrator of Mid-Western Nigeria*

APPROVED

ABUBAKAR T. BALEWA,  
*Prime Minister of the Federation*

L.N. 16 of 1964

MID-WESTERN REGION (TRANSITIONAL PROVISIONS) ACT, 1963  
(1963, No. 19)

**Mid-Western Parliamentary Election (Validation) Order, 1964**

*Commencement : 27th January, 1964*

In exercise of the powers conferred by subsection (1) of section 3 of the Mid-Western Region (Transitional Provisions) Act, 1963, and of all other powers enabling it in that behalf, the Administrative Council of Mid-Western Nigeria has made the following Order—

1. Any notice, nomination, notification or decision, given, published, made or issued under any instrument in connection with, or for the purposes of, the conduct of the elections into the Mid-Western House of Assembly scheduled to be held on the 3rd day of February, 1964, by any person or body of persons, or by any electoral officer howsoever appointed, shall be deemed always to have been valid and effectual.

Validation of  
acts done in  
connection  
with Mid-  
Western  
Elections.

**B 26**

Citation  
and Com-  
mencement.

2. This Order may be cited as the Mid-Western Parliamentary Election (Validation) Order, 1964, and shall come into force on the 27th day of January, 1964.

MADE this 27th day of January, 1964.

D. C. OSADEBAY,  
*Administrator of Mid-Western Nigeria*

APPROVED

ABUBAKAR T. BALEWA,  
*Prime Minister of the Federation*

L.N. 60 of 1964

RENT RESTRICTION ACT (CAP. 183)

The Rent Restriction (Lagos Central Planning Scheme Area)  
(Premises Decontrol) Order, 1964

Commencement : 11th June, 1964

In exercise of the powers conferred by section 16 of the Rents Restriction Act, and of all other powers enabling me in that behalf, I hereby make the following order—

1. This order may be cited as the Rent Restriction (Lagos Central Planning Scheme Area) (Premises Decontrol) Order, 1964 and shall apply to the Federal Territory only.

Short title and application.

2. The provisions of the Rent Restriction Act shall, as from the date of commencement of this order cease to apply to premises known as Lagos Executive Development Board Temporary shops situate within the Lagos Central Planning Scheme Area.

Decontrol of L.E.D.B. temporary shops in central Lagos.

DATED at Lagos this 21st day of May, 1964.

L0004/S. 31

MUSA YAR'ADUA,  
Minister of Lagos Affairs

L.N. 61 of 1964

PORTS ACT (CAP. 155)

Ports (Dues and Rates) (Amendment) Regulations, 1964

Commencement : 11th June, 1964

In exercise of the powers conferred by section 82 of the Ports Act, and of all other powers enabling it in that behalf, the Nigerian Ports Authority with the approval of the Minister of Transport hereby makes the following Regulations—

1. These Regulations may be cited as the Ports (Dues and Rates) (Amendment) Regulations, 1964.

Short title.

2. For Part III of the First Schedule to the Nigerian Ports Authority (Dues and Rates) Regulations, (which specifies the rate of Harbour Dues on Cargo) there shall be substituted the following—

Amendment of Part III of First Schedule.

“CARGO—

Harbour Dues will be paid on all cargo

(1) Unshipped in the port from a ship entering by or £ s d  
from sea:—

(a) Ports of Lagos and Port Harcourt—All cargo,  
per ton weight or measurement according to  
whether freight is chargeable on weight or  
measurement . . . . . 0 6 8

	£	s	d
(b) Ports other than Lagos and Port Harcourt—All cargo, per ton weight or measurement according to whether freight is chargeable on weight or measurement .. .. .	0	3	4
(2) Shipped in a port by a ship leaving by or for sea:—			
(a) Ports of Lagos and Port Harcourt—All cargo, per ton weight or measurement according to whether freight is chargeable on weight or measurement .. .. .	0	6	8
(b) Ports other, than Lagos and Port Harcourt—All cargo, per ton weight or measurement according to whether freight is chargeable on weight or measurement .. .. .	0	3	4
(3) Reshipped in the port by a ship leaving by or for sea:—			
(a) Ports of Lagos and Port Harcourt—All cargo, per ton weight or measurement according to whether freight is chargeable on weight or measurement .. .. .	0	6	8
(b) Ports other than Lagos and Port Harcourt—All cargo, per ton weight or measurement according to whether freight is chargeable on weight or measurement .. .. .	0	3	4
(4) Transhipped in a port:—			
(a) Ports of Lagos and Port Harcourt—			
(i) From a ship entering by or from sea per ton weight or measurement .. .. .	0	3	4
(ii) By a ship leaving by or for sea per ton weight or measurement .. .. .	0	3	4
(b) Ports other than Lagos and Port Harcourt—			
(i) From a ship entering by or from sea—per ton weight or measurement .. .. .	0	1	8
(ii) By a ship leaving by or for sea—per ton weight or measurement .. .. .	0	1	8
(5) Shipped in a port for a place outside Nigeria, either by sea or by inland waters:—			
Motor spirit, kerosene, gas oil or automotive gas oil which has been unshipped in the port in bulk—per ton weight or measurement ..	0	3	4

The Common Seal of the Nigerian Ports Authority is hereby affixed by order of the said Authority this 26th day of March, 1964, in the presence of:

BAYO KEHINDE,  
*Secretary*

J. B. DARAMOLA,  
*Temporary Chairman*

APPROVED this 26th day of May, 1964.

R. A. NJOKU,  
*Minister of Transport*

## EXPLANATORY NOTE

The Regulations are intended to correct a legal error in the Principal Regulations. Although the latter would appear to quote concessional rates of harbour dues in respect of coal mined in Nigeria (i.e. 50% of the rates charged on all other cargo), in practice no such concession is granted by the Authority. While the Nigerian Coal Corporation pays harbour dues on coal at half the rate for all other cargo, the Federal Government, by way of subsidy to the Nigerian Coal Corporation, pays the Authority the remaining half of the harbour dues actually charged on coal mined in Nigeria.

T.0160/S.35

L.N. 62 of 1964

## PORTS ACT (CAP. 155)

**Nigerian Ports Authority Docks and Premises  
(Amendment) By-laws, 1964**

*Commencement: 11th June, 1964*

**In exercise of the powers conferred by section 44 of the Ports Act and of all other powers enabling it in that behalf, the Nigerian Ports Authority hereby makes the following by-laws—**

1. These by-laws may be cited as the Nigerian Ports Authority Docks and Premises (Amendment) By-laws, 1964.

Short title.

2. The Nigerian Ports Authority Docks and Premises By-laws are amended as follows—

Amendment  
of Cap. 155  
Vol. IX.

(a) by the addition after by-law 16 of the following—

“16A. No person shall take any photograph on or within a quay or premises of the Authority except by the special permission of the Secretary to the Authority, or other authorised officer of the Authority who shall for the purpose issue a special permit on application”.

(b) by the deletion of by-law 17 and the substitution therefor of the following—

“Removal of offenders from the quay or premises”. “17. Any person infringing or not observing By-laws 14, 15, 16 or 16A may, without prejudice to the penalty prescribed, be removed from the quay or premises”.

The common Seal of the Nigerian Ports Authority was hereunto affixed by the order of the said Authority this 26th day of March, 1964, in the presence of :

BAYO KEHINDE  
*Secretary*

J. B. DARAMOLA,  
*Temporary Chairman*

APPROVED this 26th day of May, 1964.

R. A. NJOKU,  
*Minister of Transport*

EXPLANATORY NOTE

These By-laws restrict the taking of photographs on the Nigerian Ports Authority's Quays and Premises.

T 0160/S. 2

Library

Supplement to Official Gazette Extraordinary No. 17, Vol. 51, 7th February, 1964—Part B

L.N. 21 of 1964

Please note

CRIMINAL CODE ACT (CHAPTER 42)

Criminal Code (Prohibited Importations) Order, 1964

197  
17/2

Commencement : 5th February, 1964

In exercise of the powers conferred by section 58 of the Criminal Code and of all other powers enabling me in that behalf, I hereby make the following Order—

1. The importation into Nigeria of the Magazine entitled the "EVERGREEN" published by the All-China Youth Federation and the All-China Students' Federation is hereby prohibited.

Prof  
of  
imp

2. This Order may be cited as the Criminal Code (Prohibited Importations) Order, 1964, and shall come into force on the 5th day of February, 1964.

Cit  
cor  
me

MADE at Lagos, this 5th day of February, 1964.

THE LIBRARY  
NIGERIAN INSTITUTE OF  
INTERNATIONAL AFFAIRS  
G. P. O. BOX 1727  
LAGOS, NIGERIA

ABUBAKAR T. BALEWA,  
Prime Minister of the Federation

EXPLANATORY NOTE

This Order has effect of prohibiting the importation into Nigeria of the magazine entitled "EVERGREEN".

O.44/S. 3

di



L.N. 84 of 1964

IMMIGRATION ACT, 1963  
(1963, No. 6)**The Francis Xavier Ndongo—Deportation Order, 1964**

WHEREAS on the 28th day of January, 1964, FRANCIS XAVIER NDONGO was convicted of being a prohibited immigrant at the Magistrates' Court, Lagos :

AND WHEREAS the said Court in exercise of the powers conferred by subsection 1 of section 18 of the Immigration Act, 1963, recommended that the said Francis Xavier Ndongo be deported from Nigeria :

AND WHEREAS I, ALHAJI SHEHU SHAGARI, Federal Minister of Internal Affairs after considering the recommendation aforesaid, am satisfied that it is in the public interest that a deportation order be made :

NOW THEREFORE, in exercise of the powers conferred upon me by subsection 2 of section 18 of the Immigration Act, 1963, it is hereby ordered that the said FRANCIS XAVIER NDONGO shall leave Nigeria on the first available opportunity and shall thereafter remain out of Nigeria.

MADE at Lagos this 18th day of July, 1964.

MJ. 807/S. 2/M III

SHEHU SHAGARI,  
*Federal Minister of Internal Affairs*

L.N. 85 of 1964

CUSTOMS AND EXCISE MANAGEMENT ACT 1958  
(1958, No. 55)**Open General Import Licence (Hong Kong) (No. 1 of 1963)  
Amendment Notice 1964**

*Commencement : 30th July, 1964*

In exercise of the powers conferred by section 4 of the Imports Prohibition Order 1959, the Import Licensing Authority hereby amends the Schedule to the Open General Import Licence referred to herein.

1. The Schedule to the Open General Import Licence (Hong Kong) No. 1 of 1963 is hereby amended by the addition of the following item:—

	<i>Import Group</i>	<i>Item No.</i>
“23. Blankets, other material . . . .	656	69”

Amendment  
of L.N. 121  
of 1963.

2. This notice may be cited as the Open General Import Licence (Hong Kong) (No. 1 of 1963) Amendment Notice 1964 and shall apply throughout the Federation.

Citation and  
application.

MADE at Lagos this 30th day of July, 1964.

J. B. ELUMEZE,  
*Import Licensing Authority,  
Federal Ministry of Commerce and Industry*

## EXPLANATORY NOTE

*(This note is not part of the Notice but is intended to explain its effect).*

The effect of this amendment is that specific import licence is now required for the importation into Nigeria from Hong Kong of the goods listed in the above Legal Notice.

**L.N. 86 of 1964**

**CUSTOMS AND EXCISE MANAGEMENT ACT 1958**  
(1958, No. 55)

**Open General Import Licence (Japan) (No. 3 of 1959)**  
**Amendment Notice 1964**

*Commencement : 30th July, 1964*

In exercise of the powers conferred by section 4 of the Imports Prohibition Order 1959, the Import Licensing Authority hereby amends the Second Schedule to the Open General Import Licence referred to herein.

Amendment of L.N. 238 of 1959.

1. The Schedule to the Open General Import Licence (Japan) No. 3 of 1959 is hereby amended by the addition of the following item :—

Citation and application.

"24. Blankets, other material	<i>Import Group</i>	<i>Item No.</i>
	656	69"

2. This notice may be cited as the Open General Import Licence (Japan) (No. 3 of 1959) Amendment Notice 1964 and shall apply throughout the Federation.

MADE IN Lagos this 30th day of July, 1964.

J. B. ELUMEZE,  
*Import Licensing Authority,*  
*Federal Ministry of Commerce and Industry,*

**EXPLANATORY NOTE**

*(This note is not part of the Notice but is intended to explain the effect).*

The effect of this amendment is that specific import Licence is now required for the importation into Nigeria from Japan of the goods listed in the above Legal Notice.

**L.N. 87 of 1964**

**CUSTOMS AND EXCISE MANAGEMENT ACT 1958**  
(1958, No. 55)

**Open General Import Licence (Dollar Area) (No. 4 of 1959)**  
**Amendment Notice 1964**

*Commencement : 30th July, 1964*

In exercise of the powers conferred by section 4 of the Imports Prohibition Order 1959, the Imports Licensing Authority hereby amends the Schedule to the Open General Import Licence referred to herein.

Amendment of L.N. 239 of 1959.

1. The Schedule to the Open General Import Licence (Dollar Area) No. 4 of 1959 is hereby amended by the addition of the following item :—

"36. Blankets, other material	<i>Import Group</i>	<i>Item No.</i>
	656	69"

The following Bills, which will in due course be presented to Parliament for enactment, are published for general information.

**SUPPLEMENTARY APPROPRIATION (1962-63) BILL**

**EXPLANATORY MEMORANDUM**

This Bill makes final Supplementary provision for the service of the Federation for the financial year, 1962-63.

F. S. OKOTIE-BOOH,  
*Minister of Finance*

**A BILL**

**FOR**

AN ACT TO AUTHORISE THE ISSUE OUT OF THE CONSOLIDATED REVENUE FUND OF FOUR HUNDRED AND EIGHT THOUSAND AND FORTY POUNDS FOR THE PURPOSE OF MAKING FURTHER PROVISION FOR THE SERVICE OF THE YEAR WHICH ENDED ON THE THIRTY-FIRST DAY OF MARCH, ONE THOUSAND, NINE HUNDRED AND SIXTY-THREE; AND TO APPROPRIATE THAT SUM FOR THE PURPOSES SPECIFIED IN THIS ACT.

BE IT ENACTED by the Legislature of the Federation of Nigeria in this present Parliament assembled and by the authority of the same as follows:—

1. The total of the amounts mentioned in section one of the  
5 Appropriation Act, 1962, section one of the Supplementary Appropriation  
(1962-63) Act, 1963 (which together provide for the issue out of the  
Consolidated Revenue Fund in respect of the year which ended on  
the 31st day of March, 1963, of sums not exceeding in aggregate  
10 £55,395,871) shall be increased by four hundred and eight thousand  
and forty pounds; and the additional amount shall be appropriated to  
heads of expenditure as indicated in the Schedule to this Act.

2. This Act may be cited as the Supplementary Appropriation  
(1962-63) Act, 1964 and shall apply throughout the Federation.

Commence-  
ment.

Issue and appropria-  
tion of  
£408,040  
from  
Consoli-  
dated  
Revenue  
Fund for  
the service  
of 1962-63.  
1962,  
Nos. 5 and  
22; 1963,  
No. 13.

Short  
title and  
extent.

Section 1  
Head

**SCHEDULE**

	Amount
	£
30 Ministry of Economic Development	204,844
33 Forestry (Research)	1,435
48 Prisons	69,428
65 Non Statutory Appropriations of Revenue	132,333
<b>Total</b>	<b>£408,040</b>



Supplement to Official Gazette Extraordinary No. 4, Vol. 51, 8th January, 1964  
—Part B

L.N. 1 of 1964

CUSTOMS TARIFF ACT, 1958  
(No. 60 of 1958)

**Customs Tariff (Duties and Exemptions) (No. 1) Order, 1964**

*Commencement : 8th January, 1964*

In exercise of the powers conferred by subsection (1) of section 6 of the Customs Tariff Act, 1958, the President, acting in accordance with the advice of the Council of Ministers, hereby makes the following Order—

1. This Order may be cited as the Customs Tariff (Duties and Exemptions) (No. 1) Order, 1964 and shall apply throughout the Federation.

Short title  
and applica-  
tion.

2. The First Schedule to the Customs Tariff Act, 1958 (which relates to import duties of Customs) as the same was replaced by the Customs Tariff (Duties and Exemptions) Order, 1962, is amended by the deletion of the figures "0", "19" and "0" where they occur in item 38 and the substitution therefor of the figures "1", "10" and "0" respectively.

Amendment  
of First  
Schedule to  
L.N. 60 of  
1958. L.N.  
25 of 1962.

MADE at Lagos this 7th day of January, 1964.

R. C. ONYEJEU,  
*Acting Deputy Secretary to  
the Council of Ministers*

EXPLANATORY NOTE

This Order increases the duty on matches from 19s to 30s per gross boxes.



L.N. 2 of 1964

**INDUSTRIAL DEVELOPMENT (INCOME TAX RELIEF) ACT  
(CAP. 87)**

**Industrial Development (Income Tax Relief) (Yeast) Order, 1964**

*Commencement : 2nd January, 1964*

WHEREAS a representation has been received pursuant to subsection (1) of section 3 of the Industrial Development (Income Tax Relief) Act for the making of an Order declaring the industry and the product set out in the Schedule to this Order to be a pioneer industry and a pioneer product respectively :

AND WHEREAS all necessary steps pursuant to subsections (1) and (2) of section 3 of the said Act have been taken by the Minister :

NOW THEREFORE, in exercise of the powers conferred by subsection (2) of section 3 of the Industrial Development (Income Tax Relief) Act, the President has made the following Order—

1. This Order may be cited as the Industrial Development (Income Tax Relief) (Yeast) Order, 1964 and shall apply throughout the Federation.

Citation and application.

2. The industry and its product set out in the Schedule hereto are hereby declared as a pioneer industry and a pioneer product respectively.

Declaration of pioneer industry and pioneer product.

---

**SCHEDULE**

<i>Industry</i>	<i>Product</i>
The manufacture of Yeast	Yeast

MADE at Lagos, this 2nd day of January, 1964.

R. C. ONYEJEPU,  
*Acting Deputy Secretary to the  
Council of Ministers*

**EXPLANATORY NOTE**

The purpose of this Order is to declare the manufacture of yeast and its product pioneer industry and pioneer product respectively.

L.N. 3 of 1964

INDUSTRIAL DEVELOPMENT (INCOME TAX RELIEF) ACT  
(CAP. 87)

**Industrial Development (Income Tax Relief)  
(Starch) Order, 1964**

*Commencement : 2nd January, 1964*

WHEREAS a representation has been received pursuant to subsection (1) of section 3 of the Industrial Development (Income Tax Relief) Act for the making of an Order declaring the industry and the product set out in the Schedule to this Order to be a pioneer industry and a pioneer product respectively:

AND WHEREAS all necessary steps pursuant to subsections (1) and (2) of section 3 of the said Act have been taken by the Minister :

NOW THEREFORE, in exercise of the powers conferred by subsection (2) of section 3 of the Industrial Development (Income Tax Relief) Act, the President has made the following Order—

Citation and application.

1. This Order may be cited as the Industrial Development (Income Tax Relief) (Starch) Order, 1964 and shall apply throughout the Federation.

Declaration of pioneer industry and pioneer product.

2. The industry and its product set out in the Schedule hereto are hereby declared as a pioneer industry and a pioneer product respectively.

SCHEDULE

<i>Industry</i>	<i>Product</i>
The manufacture of Starch .. .. .	Starch

MADE at Lagos this 2nd day of January, 1964.

R. C. ONYEJEFU,  
*Acting Deputy Secretary to the  
Council of Ministers*

EXPLANATORY NOTE

The purpose of this Order is to declare the manufacture of starch and its product a pioneer industry and a pioneer product respectively.

L.N. 4 of 1964

## MONEYLENDERS ACT (CHAPTER 124)

**Commonwealth Development Corporation (Exemption)  
Order, 1963***Commencement : 9th January, 1964*

In exercise of the powers conferred by section 2A of the Moneylenders Act, as amended by the Moneylenders (Amendment) Act, 1960, and of all other powers enabling me in that behalf I hereby make the following Order—

1. This order may be cited as the Commonwealth Development Corporation (Exemption) Order, 1963 and shall apply to the Federal Territory of Lagos only. Citation and application.

2. The Commonwealth Development Corporation, a body corporate established by an Act of the Parliament of the United Kingdom, which has its principal place of business in Nigeria at 5 Customs Street, Lagos, shall be exempt from the provisions of the Moneylenders Act. Exemption of Commonwealth Development Corporation. Cap. 124.

MADE at Lagos this 21st day of December, 1963.

ALHAJI SHEHU SHAGARI,  
*Federal Minister of Internal Affairs*

## EXPLANATORY MEMORANDUM

The purpose of this Order is to enable the Commonwealth Development Corporation to invest its funds in economic development projects in the Federal Territory of Lagos.

This Order replaces the Order published as Legal Notice 142 in Gazette No. 90 of 14th November, 1963.

MIA1463

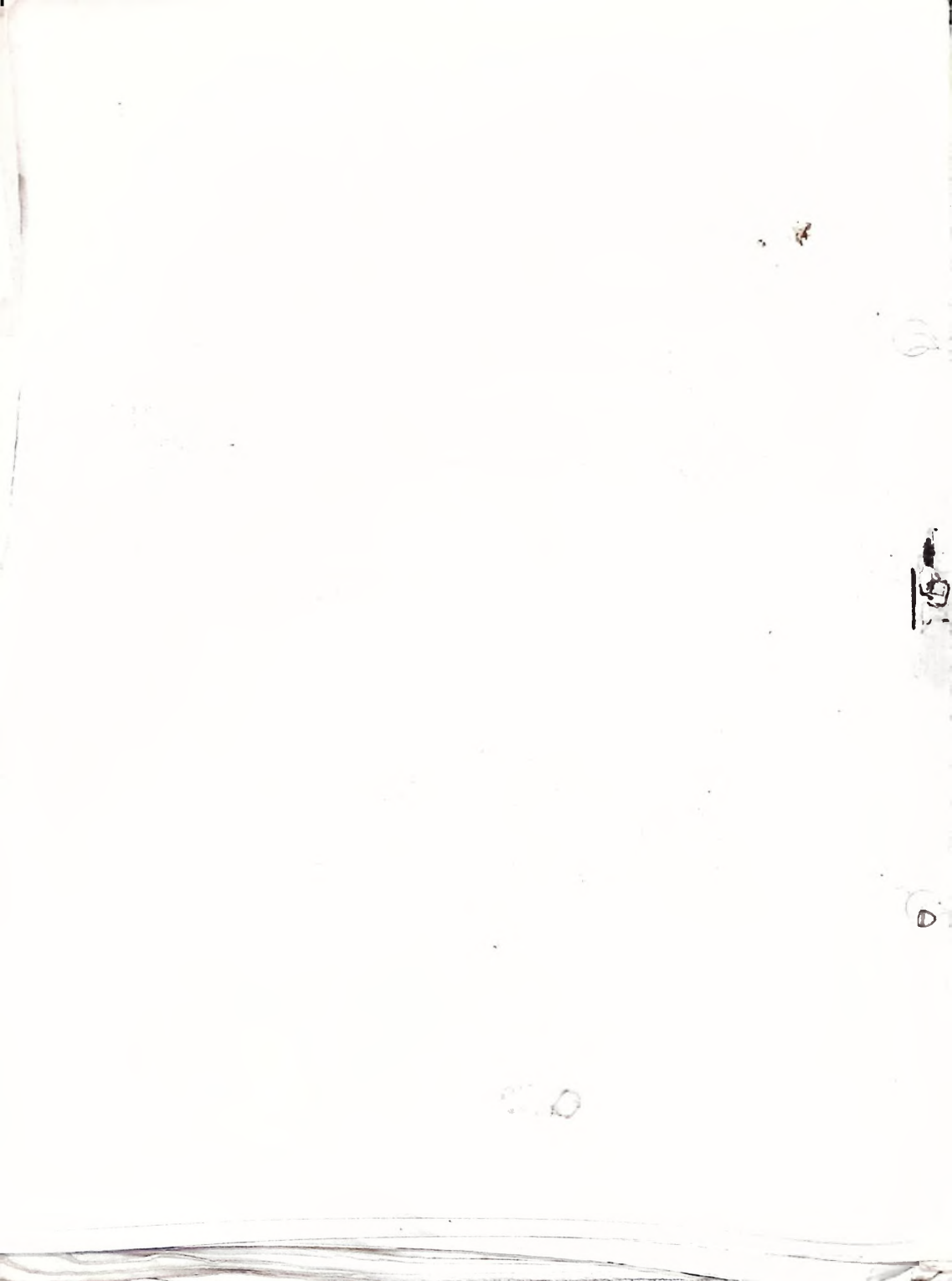

## L.N. 8 of 1964

CUSTOMS AND EXCISE MANAGEMENT ACT, 1958  
(No. 55 of 1958)

## Drawback (Customs) (Amendment) Regulations, 1964

Commencement : 16th January, 1964

In exercise of the powers conferred by subsection (1) of section 122 of the Customs and Excise Management Act, 1958, and of all other powers enabling him in that behalf, the President hereby makes the following regulations—

1. These regulations may be cited as the Drawback (Customs)(Amendment) Regulations, 1964, and shall apply throughout the Federation.

Citation  
and applica-  
tion.

2. The Drawback (Customs) Regulations, 1959, are hereby amended by the deletion of the Schedule thereto and the substitution therefor of the following—

Amendment  
of the  
Schedule.  
L.N. 70 of  
1959.

## SCHEDULE (Regs. 4 and 9)

## DRAWBACK ON IMPORTED GOODS USED IN MANUFACTURE IN NIGERIA

<i>Imported material</i>	<i>Conditions for grant of drawback</i>	<i>Amount of drawback</i>
(1) All imported goods	(a) Used in the manufacture of goods exported from Nigeria. (b) Used in the local manufacture of goods specified by the Board which are purchased by, and are for the official or personal use of, organisations or persons entitled to duty-free importation of similar or identical goods.	100 per cent of the import duty paid. 100 per cent of the import duty paid.
(2) Paper	Used in the manufacture of goods supplied for educational purposes to educational establishments recognised by the Chief Federal Adviser on Education.	100 per cent of the import duty paid
(3) Imported manufactured tobacco in respect of which there has been paid an import duty of not less than 24s per pound weight.	Used in the manufacture of cigarettes by tobacco manufacturers.	8s-9d per pound weight.

MADE at Lagos this 16th day of January, 1964.

R. C. ONYEJFPU,  
Acting Deputy Secretary  
to the Council of Ministers

EXPLANATORY NOTE

The purpose of these regulation is to encourage local manufacture of goods for the use of organisations or persons entitled to duty-free importation of materials needed for the manufacture of such goods. These regulations allow of drawback of any import duties paid on such materials.

S. 305/6

Supplement to Official Gazette Extraordinary No. 10, Vol. 51, 18th January,  
1964—Part B

L.N. 9 of 1964

MID-WESTERN REGION (TRANSITIONAL PROVISIONS)  
ACT, 1963

**Parliamentary Electoral Regulations  
(Amendment) Order, 1964**

*Commencement : 17th January, 1964*

In exercise of the powers conferred by and under section 3 of the Mid-Western Region (Transitional Provisions) Act, 1963, the Administrative Council of Mid-Western Nigeria has made the following Order—

1. Paragraph (4) of Regulation 12 of Parliamentary Electoral Regulations, 1960, published as W.R.L.N. 227 of 1960, is hereby amended by deleting therefrom the expression "fourteenth" occurring between the words "the" and "day" in line 4 and substituting the expression "twelfth" therefor.

Amendment  
of Regulation  
W.R.L.N.  
227 of 1960.

2. This Order may be cited as the Parliamentary Electoral Regulations (Amendment) Order, 1964, and shall come into force on 17th day of January, 1964.

Citation and  
date of  
commence-  
ment.

MADE at Benin City this 17th day of January, 1964.

D. C. OSADEBAY,  
*Administrator of Mid-Western Nigeria*

APPROVED

ABUBAKAR TAFAWA BALEWA,  
*Prime Minister*



L.N. 10 of 1964

PUBLIC ORDER (LAGOS) ACT, CAP. 169

The Public Order (Lagos) (No. 1) Order, 1964

Commencement : 22nd January, 1964

WHEREAS I am of the opinion that, by reason of particular circumstances existing in Lagos, the powers conferred upon the Minister charged with responsibility for Lagos municipal affairs by subsection (1) of section five of the Public Order (Lagos) Act will not be sufficient to prevent serious public disorder being occasioned by the holding of public meetings or public processions in Lagos.

NOW THEREFORE, in exercise of the powers conferred on me by that section, I hereby make the following order :—

1.—(1) No public meeting or public procession (other than those excepted from the provisions of this sub-paragraph by the following sub-paragraph) shall be held in Lagos during the period of two months beginning with the time when this order comes into force.

(2) There shall be excepted from the provisions of the foregoing sub-paragraph any public meeting or public procession specified in a notice which is—

(a) signed by me or by an officer of the Ministry of Lagos Affairs not below the rank of Senior Assistant Secretary ; and

(b) served on an officer of the Nigeria Police not below the rank of Senior Superintendent.

2. This order may be cited as the Public Order (Lagos) (No. 1) Order, 1964, and shall come into force at eleven o'clock on the evening of the twenty-second day of January, Nineteen hundred and sixty-four.

MADE at Lagos this 20th day of January, 1964.

MUSA YAR'ADUA,  
Minister of Lagos Affairs

SL0338

Prohibition  
of public  
meetings  
public  
procession  
in Lagos

Citation  
and  
commen-  
ment.